

FM IF Amplifier and Demodulator for TV Sound Application

Technology: Bipolar

Features

- Outstanding limiting qualities
- Very few external components
- Wide supply voltage range
- High ripple rejection
- Minimum IF passage to audio output
- High IF residual carrier rejection
- U828B with integrated de-emphasis resistor

Case: 8-pin dual-inline plastic

Absolute Maximum Ratings

Reference point Pin 3

Parameters	Symbol	Value	Unit
Supply voltage Pin 7	V_S	18	V
Power dissipation $T_{amb} = 70^\circ\text{C}$	P_{tot}	550	mW
Junction temperature	T_i	125	$^\circ\text{C}$
Ambient-temperature range	T_{amb}	-15 to +70	$^\circ\text{C}$
Storage-temperature range	T_{stg}	-25 to +125	$^\circ\text{C}$

Thermal Resistance

Parameters	Symbol	Maximum	Unit
Junction ambient	R_{thJA}	100	K/W

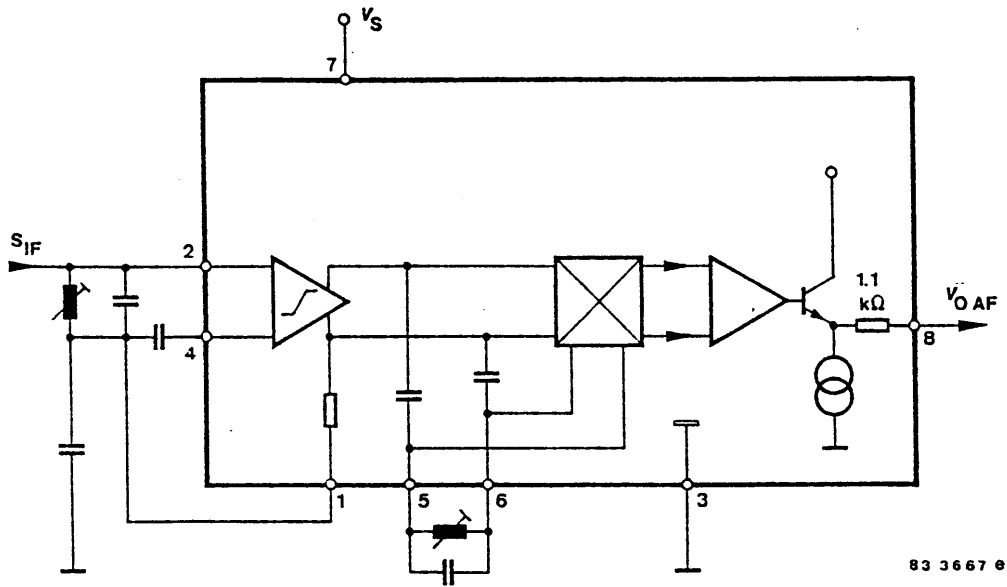

Figure 1. Block diagram U828B

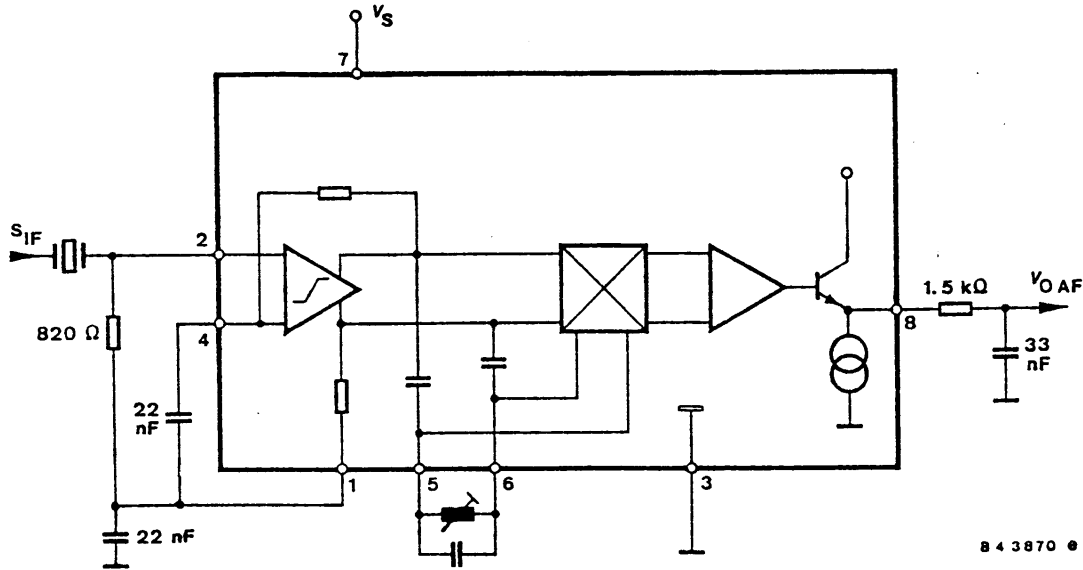

Figure 2. Block diagram U829B

Electrical Characteristics

$V_S = 12\text{ V}$, reference point Pin 3, $T_{\text{amb}} = 25^\circ\text{C}$, unless otherwise specified

Parameters	Test Conditions / Pin	Symbol	Min.	Typ.	Max.	Unit
Supply voltage range	Pin 7	V_S	10		18	V
Supply current	Pin 7	I_S	9.5	14	17.5	mA
Frequency range		f			12	MHz
Input voltage for limitation	f = 5.5 MHz, $\Delta f = \pm 50\text{ kHz}$, $f_{\text{mod}} = 1\text{ kHz}$, $Q^{1)} = 45$					
	Pin 2	v_i		75	90	μV
Input impedance	Pin 2	R_i	15	40		$\text{k}\Omega$
		C_i		4.5	6	pF
Output impedance		R_o			200	Ω
AM rejection	f = 5.5 MHz, $\Delta f = \pm 50\text{ kHz}$, m = 30%, $Q^{1)} = 45$, $V_i = 500\ \mu\text{V}$	k_{AM}	50	60		dB
DC voltage at AF output	$V_i = 0$ Pin 8					
	U828B	V_O		5.6		V
	U829B	V_O		4.0		V
Ripple rejection	Pin 7,8	k_{hum}		35		dB
IF residual voltage without C_D	Pin 8	V_{OIF}		20		mV
AF output voltage	$V_i = 10\text{ mV}$, f = 5.5 MHz, $\Delta f = \pm 50\text{ kHz}$, $f_{\text{mod}} = 1\text{ kHz}$, $Q^{1)} = 45$ Pin 8					
	U828B	V_{OAF}	0.8		1.3	V
Group 0	= U829B	V_{OAF}	1.0		1.90	V
Group 1	= U829BS	V_{OAF}	1.0		1.25	V
Group 2	= U829BS	V_{OAF}	1.22		1.55	V
Group 3	= U829BS	V_{OAF}	1.52		1.90	V
$Q^{1)} = 20$	U828B	V_{OAF}		0.65		V
	U829B	V_{OAF}		0.8		V
Distortion	Pin 8 f = 5.5 MHz, $V_i = 10\text{ mV}$, FM-Hub = 50 kHz, $f_{\text{mod}} = 1\text{ kHz}$					
$Q^{1)} = 45$		d		3.0		%
$Q^{1)} = 20$		d		1.0		%
Signal-to-noise ratio	$V_i = 10\text{ mV}$ (unmodulated), according to DIN 45 405 (A-weighted) Pin 8		70	80		dB
Mute function						
Switching current		I_{sw}			400	μA
Switching voltage		V_{mute}	3			V

¹⁾ Operation quality factor for the demodulator circuit

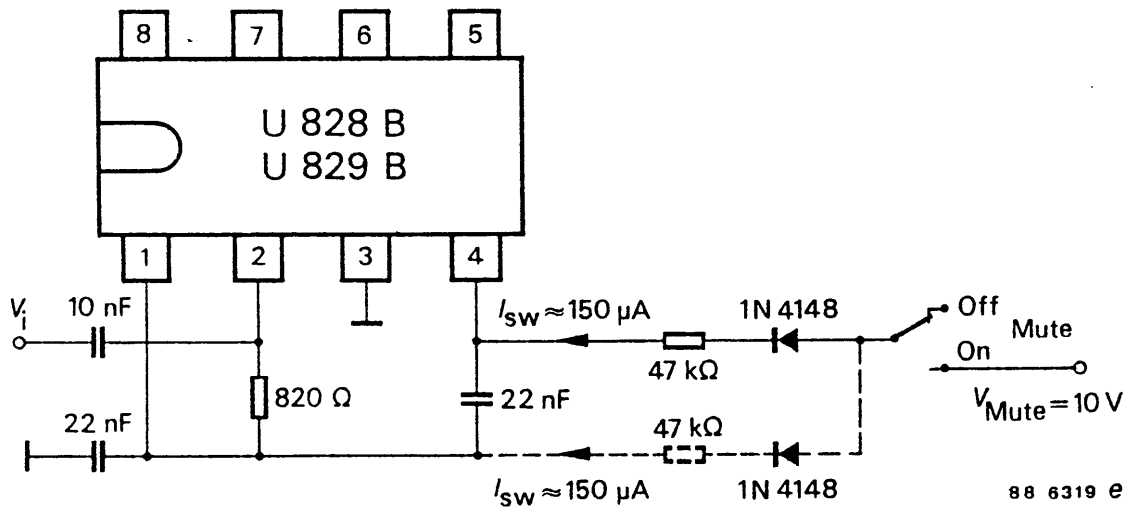

Figure 3.

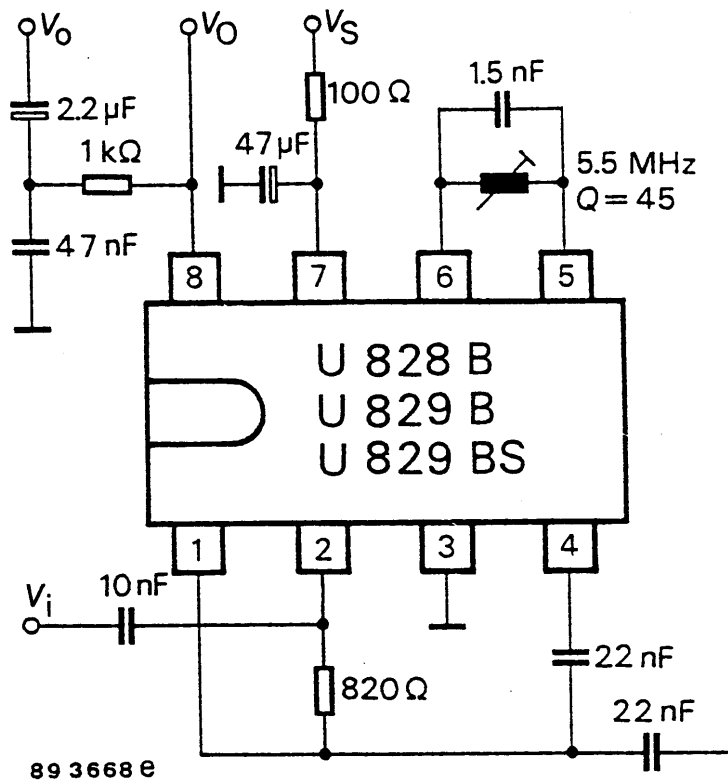
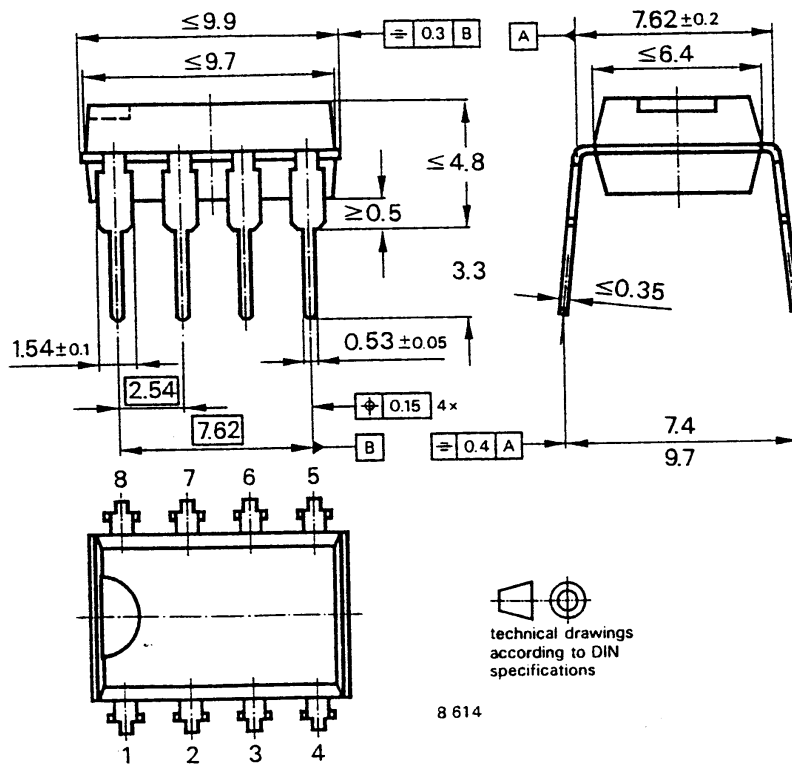

Figure 4. Test circuit

(The supply voltage must be disconnected before inserting the integrated circuit in the socket.)

Dimensions in mm

Package: DIP8



Ozone Depleting Substances Policy Statement

It is the policy of **TEMIC TELEFUNKEN microelectronic GmbH** to

1. Meet all present and future national and international statutory requirements.
2. Regularly and continuously improve the performance of our products, processes, distribution and operating systems with respect to their impact on the health and safety of our employees and the public, as well as their impact on the environment.

It is particular concern to control or eliminate releases of those substances into the atmosphere which are known as ozone depleting substances (ODSs).

The Montreal Protocol (1987) and its London Amendments (1990) intend to severely restrict the use of ODSs and forbid their use within the next ten years. Various national and international initiatives are pressing for an earlier ban on these substances.

TEMIC TELEFUNKEN microelectronic GmbH semiconductor division has been able to use its policy of continuous improvements to eliminate the use of ODSs listed in the following documents.

1. Annex A, B and list of transitional substances of the Montreal Protocol and the London Amendments respectively
2. Class I and II ozone depleting substances in the Clean Air Act Amendments of 1990 by the Environmental Protection Agency (EPA) in the USA
3. Council Decision 88/540/EEC and 91/690/EEC Annex A, B and C (transitional substances) respectively.

TEMIC can certify that our semiconductors are not manufactured with ozone depleting substances and do not contain such substances.

We reserve the right to make changes to improve technical design and may do so without further notice.

Parameters can vary in different applications. All operating parameters must be validated for each customer application by the customer. Should the buyer use TEMIC products for any unintended or unauthorized application, the buyer shall indemnify TEMIC against all claims, costs, damages, and expenses, arising out of, directly or indirectly, any claim of personal damage, injury or death associated with such unintended or unauthorized use.

TEMIC TELEFUNKEN microelectronic GmbH, P.O.B. 3535, D-74025 Heilbronn, Germany
Telephone: 49 (0)7131 67 2831, Fax number: 49 (0)7131 67 2423