

Flasher, 18-mΩ Shunt, Frequency Doubling Disabling

Description

The design of the U6433B is mainly based on the good results of U6043B in terms of EMC (Electro Magnetic Capability) and protection features. It includes an additional 8-mV comparator and a logical connection with the frequency doubling stage. This combination can

be used for a hazard switch which bypasses the external shunt resistor to disable the frequency doubling. This feature can be useful in the US automotive industry. During direction mode the U6433B works like other flashers, i.e., frequency doubling in the case of lamp outage.

Features

- Temperature and voltage compensated frequency
- Warning indication of lamp failure by means of frequency doubling can be disabled
- Voltage dependence of the car indicator lamps compensated for lamp failure
- Relay output with high current carrying capacity
- and low saturation voltage
- Minimum lamp load for flasher operation ≥ 1 W
- Load-dump protection
- Very low susceptibility to EMI
- Protection according to ISO/TR 7637/1 level 4

Ordering Information

Extended Type Number	Package	Remarks
U6433B-FP	SO8	

Block Diagram

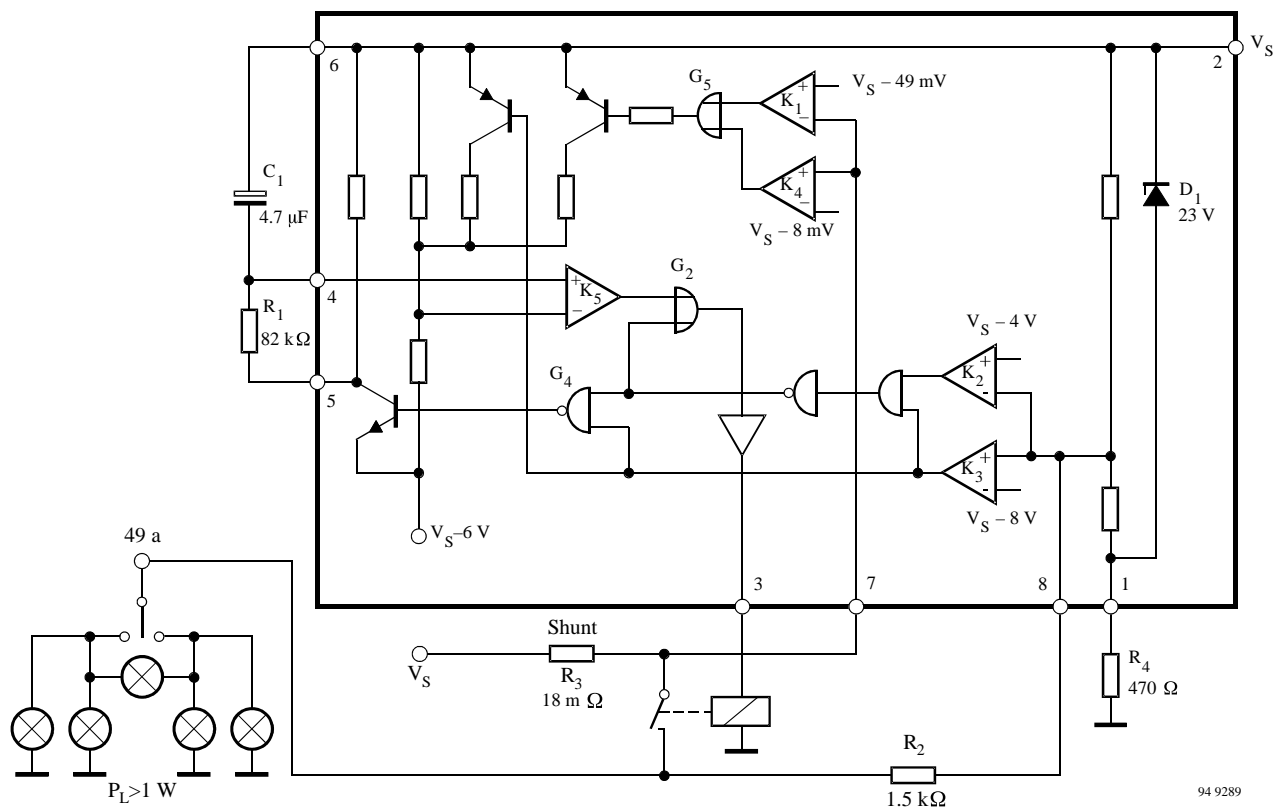
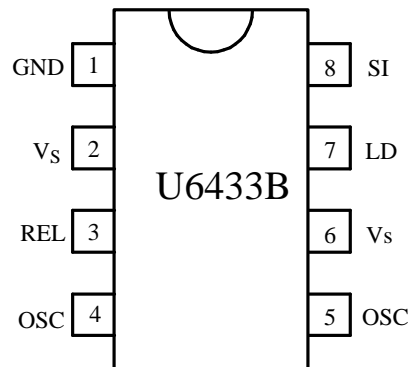

Figure 1. Application circuit as a car flasher

Pin Description

Pin	Symbol	Function
1	GND	IC ground
2	V _S	Supply voltage
3	REL	Relay driver
4	OSC	Oscillator
5	OSC	Oscillator
6	V _S	Supply voltage
7	LD	Lamp failure detection
8	SI	Start input (49a)



13298

Figure 2. Pinning

Functional Description

Pin 1, GND

The integrated circuit is protected against damage via resistor R₄ to ground (-31) in the case of battery reversal. An integrated protection circuit together with external resistances R₂ and R₄ limits the current pulses in the IC.

Pin 2, Supply voltage, V_S - Power

The arrangement of the supply connections to Pin 2 must be such as ensure that, on the connection printed circuit board (PCB), the resistance of V_S to Pin 6 is lower than that to Pin 2.

Pin 3, Relay control output (driver)

The relay control output is a high-side driver with a low saturation voltage and capable to drive a typical automotive relay with a minimum coil resistance of 60 Ω.

Pin 4 and 5 Oscillator

Flashing frequency, f₁, is determined by the R₁C₁ components as follows (see figure 1):

$$f_1 \approx \frac{1}{R_1 \times C_1 \times 1.5} \text{ Hz}$$

where $C_1 \leq 47 \mu\text{F}$
 $R_1 = 6.8 \text{ k}\Omega \text{ to } 510 \text{ k}\Omega$

In the case of a lamp outage (see Pin 7) the oscillator frequency is switched to the lamp outage frequency f₂ with f₂ ≈ 2.2 f₁.

Duty cycle in normal flashing mode: 50%
 Duty cycle in lamp outage mode: 40% (bright phase)

Pin 6, Supply voltage, Sense

For accurate monitoring via the shunt resistor, a minimized layer resistance from point V_S / shunt to Pin 6 is recommended.

Pin 7, Lamp outage detection

Control Signal Threshold 1 (49-mV Comparator K1)

The detection point for lamp failure can be calculated from the control signal threshold, typically 49 mV with V_S = 12 V. With a measuring resistance of R₃ = 18 mΩ, the frequency changeover is reached at a lamp load of 21 W + 11.4 W. The variation of the control signal threshold supply voltage takes into account the PTC characteristic of filament lamps.

Control Signal Threshold 2 (8-mV Comparator K4)

A voltage drop at R₃ between 49 mV and 8 mV shunt resistor let the flasher work in frequency doubling mode.

If the voltage drop of V_{R3MAX} = 8 mV falls the frequency doubling is disabled. This can be achieved either with a switch which by passes the shunt resistor (e.g., a special hazard warning switch) or with a small lamp load.

The arrangement of the supply connections to Pins 2 and 6 must ensure that, on the connection, PCB, the layer resistance from V_S to Pin 6 is lower than the one to Pin 2.

Flasher operation starts with a lamp load of P_L ≥ 1 W.

Pin 8, Start input

Start condition for flashing: the voltage at Pin 8 has to be below K3 threshold (flasher switch closed).

Humidity and dirt may decrease the resistance between 49 a and GND. If this leakage resistance is > 5 kΩ the IC is still kept in its off-condition. In this case the voltage at Pin 8 is between the thresholds of comparators K2 and K3.

During the bright phase the voltage at Pin 8 is above the K2 threshold, during the dark phase it is below the K3 threshold.

For proper start conditions a minimum lamp wattage of 1 W is required.

Absolute Maximum Ratings

Reference point Pin 1

Parameters		Symbol	Value	Unit
Supply voltage	Pins 2 and 6	V_S	18	V
Surge forward current	$t_p = 0.1$ ms Pins 2 and 6	I_{FSM}	1.5	A
	$t_p = 300$ ms Pins 2 and 6		1.0	A
	$t_p = 300$ ms Pin 8		30.0	mA
Output current	Pin 3	I_O	0.3	A
Power dissipation	$T_{amb} = 95^\circ\text{C}$ SO 8	P_{tot}	340	mW
	$T_{amb} = 60^\circ\text{C}$ SO 8		560	mW
Junction temperature		T_j	150	$^\circ\text{C}$
Ambient temperature range		T_{amb}	-40 to +105	$^\circ\text{C}$
Storage temperature range		T_{stg}	-55 to +150	$^\circ\text{C}$

Thermal Resistance

Parameters	Symbol	Value	Unit
Junction ambient SO8	R_{thJA}	160	K/W

Electrical Characteristics

Typical values under normal operation of the application circuit shown in figure 1, $V_S = 12$ V (Pins 2 and 6).
 $T_{amb} = 25^\circ\text{C}$, reference point ground (-31), unless otherwise specified.

Parameters	Test conditions / Pin	Symbol	Min.	Typ.	Max.	Unit
Supply voltage range	Pins 2 and 6	V_S	9		16.5	V
Supply current, dark phase	Pins 2 and 6	I_S		4.5	8	mA
Supply current, bright phase	Pins 2 and 6	I_S		7.0	11	mA
Relay output, saturation voltage	$I_O = 150$ mA, $V_S = 9$ V Pin 3	V_O			1.0	V
Relay output reverse current	Pin 3	I_O			0.1	mA
Relay coil resistance		R_L	60			Ω
Start delay	First bright phase	t_{on}			10	ms
Frequency determining resistor		R_1	6.8		510	k Ω
Frequency determining capacitor		C_1			47	μF
Frequency tolerance	Normal flashing, basic frequency f_1 not including the tolerances of the external components R_1 and C_1	Δf_1	-5		+5	%
Bright period	Basic frequency f_1 , $V_S = 9 - 15$ V	Δf_1	47		53	%
Bright period	Control frequency f_2 , $V_S = 9 - 15$ V	Δf_2	37		45	%
Frequency increase	Lamp failure, $V_S = 9 - 15$ V	f_2	$2.15 \times f_1$		$2.3 \times f_1$	Hz

Electrical Characteristics (continued)

Parameters	Test conditions / Pin	Symbol	Min.	Typ.	Max.	Unit
Control signal threshold 1	$V_S = 15\text{ V}$	V_{R3}	50	53	57	mV
	$V_S = 9\text{ V}$		43	45	47	
	$V_S = 12\text{ V}$		47	49	51	
Control signal threshold 2		V_{R3}	2		10	mV
Leakage resistance	49a to GND	R_p			5	k Ω
Lamp load		P_L	1			W

Package Information

Package SO8

Dimensions in mm

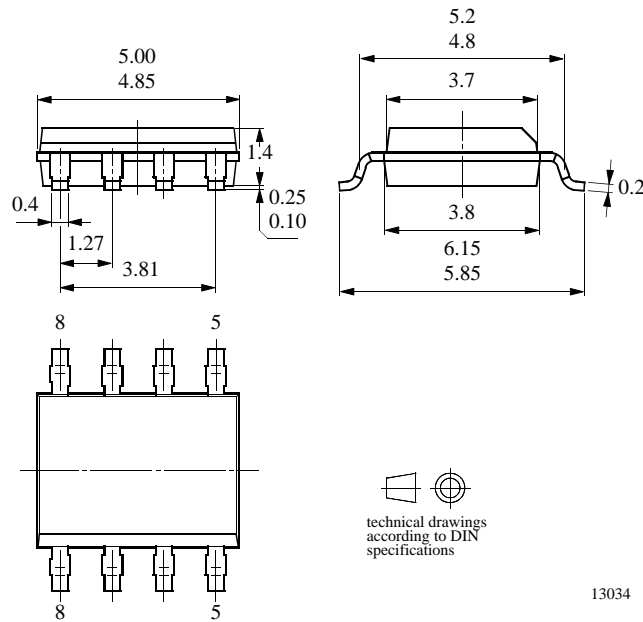

Ozone Depleting Substances Policy Statement

It is the policy of **TEMIC TELEFUNKEN microelectronic GmbH** to

1. Meet all present and future national and international statutory requirements.
2. Regularly and continuously improve the performance of our products, processes, distribution and operating systems with respect to their impact on the health and safety of our employees and the public, as well as their impact on the environment.

It is particular concern to control or eliminate releases of those substances into the atmosphere which are known as ozone depleting substances (ODSs).

The Montreal Protocol (1987) and its London Amendments (1990) intend to severely restrict the use of ODSs and forbid their use within the next ten years. Various national and international initiatives are pressing for an earlier ban on these substances.

TEMIC TELEFUNKEN microelectronic GmbH semiconductor division has been able to use its policy of continuous improvements to eliminate the use of ODSs listed in the following documents.

1. Annex A, B and list of transitional substances of the Montreal Protocol and the London Amendments respectively
2. Class I and II ozone depleting substances in the Clean Air Act Amendments of 1990 by the Environmental Protection Agency (EPA) in the USA
3. Council Decision 88/540/EEC and 91/690/EEC Annex A, B and C (transitional substances) respectively.

TEMIC can certify that our semiconductors are not manufactured with ozone depleting substances and do not contain such substances.

We reserve the right to make changes to improve technical design and may do so without further notice.

Parameters can vary in different applications. All operating parameters must be validated for each customer application by the customer. Should the buyer use TEMIC products for any unintended or unauthorized application, the buyer shall indemnify TEMIC against all claims, costs, damages, and expenses, arising out of, directly or indirectly, any claim of personal damage, injury or death associated with such unintended or unauthorized use.

TEMIC TELEFUNKEN microelectronic GmbH, P.O.B. 3535, D-74025 Heilbronn, Germany
Telephone: 49 (0)7131 67 2831, Fax number: 49 (0)7131 67 2423