

# DATA SHEET



## **SAA6750H** Encoder for MPEG2 image recording (EMPIRE)

Preliminary specification  
File under Integrated Circuits, IC02

1998 Sep 07

# Encoder for MPEG2 image recording (EMPIRE)

## SAA6750H

<b>CONTENTS</b>			
1	FEATURES	7.7	Application Specific Instruction-set Processor (ASIP)
2	GENERAL DESCRIPTION	7.7.1	General
2.1	General	7.7.2	ASIP software
2.2	Function	7.7.3	GPIO port
2.3	Application fields	7.8	Global controller
2.3.1	General	7.8.1	General
2.3.2	Video editing (PC applications)	7.8.2	Functional description
2.3.3	Camera signal transmission	7.9	I <sup>2</sup> C-bus interface and controller
2.3.4	DVD authoring	7.9.1	General
2.3.5	Video recording for surveillance	7.9.2	Special considerations
2.3.6	Digital VCR	7.9.3	I <sup>2</sup> C-bus data transfer modes
3	QUICK REFERENCE DATA	7.9.4	I <sup>2</sup> C-bus memories and registers
4	ORDERING INFORMATION	7.9.5	I <sup>2</sup> C-bus initialization
5	BLOCK DIAGRAM	7.10	DRAM interface
6	PINNING	7.10.1	General
7	FUNCTIONAL DESCRIPTION	7.10.2	Application hints
7.1	Global architecture description	7.10.3	Functional description
7.1.1	General	7.11	FIFO memories
7.1.2	Architecture structure	7.12	Clock distribution
7.2	Start-up and operation modes	7.13	Input/output levels
7.2.1	Start-up requirements	7.14	Boundary scan test
7.2.2	Reset processing	7.14.1	General
7.2.3	Description of operation modes	7.14.2	Initialization of boundary scan circuit
7.2.4	Pin behaviour	7.14.3	Device identification codes
7.3	Video front-end and formatter	8	LIMITING VALUES
7.3.1	General	9	THERMAL CHARACTERISTICS
7.3.2	Data input format	10	CHARACTERISTICS
7.3.3	Functional description	11	APPLICATION INFORMATION
7.4	MacroBlock Processor (MBP)	12	PACKAGE OUTLINE
7.4.1	General	13	SOLDERING
7.4.2	Functional description	13.1	Introduction
7.5	Bit stream assembly	13.2	Reflow soldering
7.5.1	General	13.3	Wave soldering
7.5.2	Pre-packer and packer	13.4	Repairing soldered joints
7.5.3	Stuffing unit and output buffer	14	DEFINITIONS
7.6	Data output port	15	LIFE SUPPORT APPLICATIONS
7.6.1	General	16	PURCHASE OF PHILIPS I <sup>2</sup> C COMPONENTS
7.6.2	Data output format		
7.6.3	Functional description		

# Encoder for MPEG2 image recording (EMPIRE)

SAA6750H

## 1 FEATURES

- Digital YUV input according to "ITU-T 601" and to "ITU-T 656"
- NTSC and PAL (720 pixel × 480 lines at 60 Hz and 720 pixel × 576 lines at 50 Hz)
- Integrated colour conversion 4 : 2 : 2 to 4 : 2 : 0
- Integrated format conversion to SIF format (optional)
- Real time MPEG2 Simple Profile at Main Level (SP@ML) encoding
- IP frame or I frame only encoding supported
- Programmable Group Of Pictures (GOP) size
- Integrated motion estimation, half pixel accuracy, search range 128 × 128 pixels
- Motion compensated noise reduction
- Elementary stream data output compliant to MPEG2 standard ("ISO 13818-2")
- Constant Bit-Rate (CBR) and Variable Bit-Rate (VBR) supported
- Bitstream output compatible to 16-bit parallel interface with Motorola (68xxx like) or Intel (xxx86 like) protocol style
- Adaptable to dedicated applications by embedded software
- Standard software package available (refer to software specification)
- No external host processor required
- High speed real time port for processor co-processor applications
- Only 4 × 4 Mbit external DRAM required
- I<sup>2</sup>C-bus controlled
- Single external video clock 27 MHz
- Power supply 3.3 V
- Digital inputs 5 V tolerant
- Boundary Scan Test (BST) supported.



## 2 GENERAL DESCRIPTION

### 2.1 General

The SAA6750H is a new approach towards a stand-alone MPEG2 video encoder IC. It combines high quality SP at ML compliant real time encoding with cost-effectiveness, allowing for the first time the use of an MPEG2 encoder IC in applications and markets with a high cost pressure. This has been achieved by means of a number of innovations in architecture and algorithms developed by the Philips Research Laboratories. E.g.:

- The unique motion estimation algorithm supports highly efficient encoding by using only I frame and IP frame mode. B frames need not be used. This leads to a significantly smaller internal circuitry and also reduces DRAM memory requirements from at least 4 to 2 Mbyte. In addition, the absence of B frames simplifies editing of the compressed data stream.
- The patented, motion-compensated temporal noise filtering which was developed by Philips for professional equipment reduces noise in the input video before compression is performed. This technique gives visible improvements in picture quality, especially in the field of home recordings with noisy signal sources where this has proved to be of significant benefit.

Internally the SAA6750H uses a hardware solution for data compression and a specially developed high performance processor for control purposes. This programmable embedded Digital Signal Processor (DSP) approach allows Philips to tailor various customized sets of functions for this IC. Contact Philips for information on available software packages.

## Encoder for MPEG2 image recording (EMPIRE)

SAA6750H

### 2.2 Function

The SAA6750H is a stand-alone single chip video encoder performing real time MPEG2 compression of digital video data.

The video data input of the SAA6750H accepts a digital YUV video data stream in ITU-T 601-format. PAL standard at 50 Hz and 720 pixel by 576 lines, as well as NTSC at 60 Hz and 720 pixel by 480 lines, are covered. The video synchronization may either follow ITU-T 656 recommendation or can also be supplied by external signals. The external reference clock VCLK = 27 MHz has to be synchronized to the video data.

Philips Semiconductor's SAA7111 product family provides a suitable video data stream and reference clock. Other sources are also supported by the flexible I<sup>2</sup>C-bus controlled data input interface of the SAA6750H. See Section 7.3 for detailed information.

An internal 4 : 2 : 2 to 4 : 2 : 0 colour format conversion is performed. Optionally, a ITU-T 601 to SIF format conversion may be activated by I<sup>2</sup>C-bus control settings.

The real time data encoding part of the SAA6750H combines high-compression rates with high quality picture performance. This is achieved by the integration of Philips unique motion estimation algorithm, providing a search range of 128 by 128 pixels, and a patented motion-compensated noise filtering. The compression algorithm uses I or IP mode encoding. Normally it selects automatically the suitable mode but may also be forced only to I mode operation by I<sup>2</sup>C-bus control settings.

In contrast to the encoding part which is designed in dedicated hardware, control functions and data stream handling tasks like e.g. header generation and bit-rate control are carried out by a dedicated control processor, the so-called Application Specific Instruction-set Processor (ASIP). The ASIP's microcode is contained in an internal RAM and is loaded via I<sup>2</sup>C-bus before start of operation. This architecture allows Philips to customize the SAA6750H to specific applications by generating different versions of the embedded microcode. Philips will provide software packages for several applications.

The ASIP is able to communicate with the outside world by I<sup>2</sup>C-bus and by a high speed parallel port, the GPIO port.

The SAA6750H generates an MPEG2 Elementary Stream (ES) in accordance with the MPEG2 standard ("ISO 13818-2"). Either Constant Bit-Rate (CBR) or Variable Bit-Rate (VBR) output data can be generated. The 16-bit data output interface supports Motorola (68xxx like) and Intel (xxx86 like) protocol style.

Data processing and control functions are managed by loosely coupled processes. FIFO memories are used to connect these processes. In addition to these internal storages the SAA6750H needs 4 × 4 Mbit of external DRAM memory (t<sub>RAC</sub> = 60 ns). A block diagram is shown in Fig.1.

Selectable I<sup>2</sup>C-bus addresses and a special reset mode affecting the output pin behaviour allow the use of two SAA6750H devices in one application.

### 2.3 Application fields

#### 2.3.1 GENERAL

The SAA6750H can be applied within the following application domains:

- Video editing (PC applications)
- Camera signal transmission
- Digital Versatile Disc (DVD) authoring
- Video recording for surveillance
- Digital VCR.

All those systems have to compress video data in order to manage the storage or transmission of digitized video data. The SAA6750H can be handled for most of the applications as a stand-alone device. That means at start-up a microcode and a couple of I<sup>2</sup>C-bus settings are loaded and the SAA6750H is started. If needed, settings like GOP size or bit-rate are changed on-the-fly via I<sup>2</sup>C-bus.

Two basic modes of encoding will be supported by standard microcode packages: Encoding at VBR or CBR.

The GPIO port allows high speed data exchange between the embedded DSP and an external processor. Therefore applications like DVD-authoring are supported.

#### 2.3.2 VIDEO EDITING (PC APPLICATIONS)

For video editing the SAA6750H can be interfaced gluelessly to a video input processor with ITU-T 565 compliant digital video output. In order to link the SAA6750H to the PC, the use of the PCI bridge SAA7146 is recommended. By this bridge the MPEG2 video ES can be transmitted via the PCI-bus on a Hard Disc (HD). Furthermore all I<sup>2</sup>C-bus settings can be sent from the PC via the bridge to the I<sup>2</sup>C components on the encoder board. The SAA7146 supports Pulse Code Modulation (PCM) audio capturing. Multiplexing with an audio stream or audio encoding can be done by the PC's CPU. A block diagram is shown in Fig.23.

## Encoder for MPEG2 image recording (EMPIRE)

SAA6750H

### 2.3.3 CAMERA SIGNAL TRANSMISSION

In this application the SAA6750H will be located within a camera to compress the received digital video data for transmission. Typically VBR mode will be used.

### 2.3.4 DVD AUTHORIZING

For DVD authoring the video data has to be encoded in two steps. During the first step the complexity of the video sequence is measured and the results are stored externally. During the second pass the measured complexity is used as an input for the bit-rate control.

This application can be realized by a processor co-processor approach. The SAA6750H, which is working as a co-processor, and a host processor are communicating via the GPIO port. A specific microcode package supports this mode.

### 2.3.5 VIDEO RECORDING FOR SURVEILLANCE

For surveillance systems VCRs with a huge amount of storage capacity are required. A high picture resolution is

very important when there is action in the captured picture. The SAA6750H can control its encoded bit-rate by motion detection by its integrated motion estimation algorithm. Doing so the bit-rate can vary from 0.5 to 10 Mbit/s. VCRs with a storage space of 6 month are possible.

### 2.3.6 DIGITAL VCR

In stand-alone VCRs the SAA6750H works together with an audio encoder and a multiplexer. The SAA6750H is clocked by the video clock of the video input processor (SAA7111 or derivatives). A master clock is derived from the frame pulse. The video clock and master clock domain are de-coupled by a FIFO. The audio clock can be derived from the master clock. The video Packetized Elementary Stream (PES) packetizer has to take care of the fullness of SAA6750H's output buffer.

## 3 QUICK REFERENCE DATA

SYMBOL	PARAMETER	MIN.	TYP.	MAX.	UNIT
V <sub>DD</sub>	digital supply voltage	3.0	3.3	3.6	V
I <sub>DD(tot)</sub>	total digital supply current	–	tbf	0.56	mA
P <sub>tot</sub>	total power dissipation	–	tbf	2.0	W
f <sub>VCLK</sub>	video clock frequency	25.6	27.0	28.6	MHz
f <sub>SCL</sub>	I <sup>2</sup> C-bus input clock frequency	100	–	400	kHz
B	output bit-rate	1.5	–	40	Mbit/s
V <sub>IH</sub>	HIGH-level digital input voltage	2.0	–	5.5	V
V <sub>IL</sub>	LOW-level digital input voltage	–0.5	–	+0.8	V
V <sub>OH</sub>	HIGH-level digital output voltage	2.4	–	V <sub>DD</sub>	V
V <sub>OL</sub>	LOW-level digital output voltage	–	–	0.4	V
T <sub>amb</sub>	operating ambient temperature	0	–	70	°C

## 4 ORDERING INFORMATION

TYPE NUMBER	PACKAGE		
	NAME	DESCRIPTION	VERSION
SAA6750H	SQFP208	plastic shrink quad flat package; 208 leads (lead length 1.3 mm); body 28 × 28 × 3.4 mm	SOT316-1

# Encoder for MPEG2 image recording (EMPIRE)

## SAA6750H

### 5 BLOCK DIAGRAM

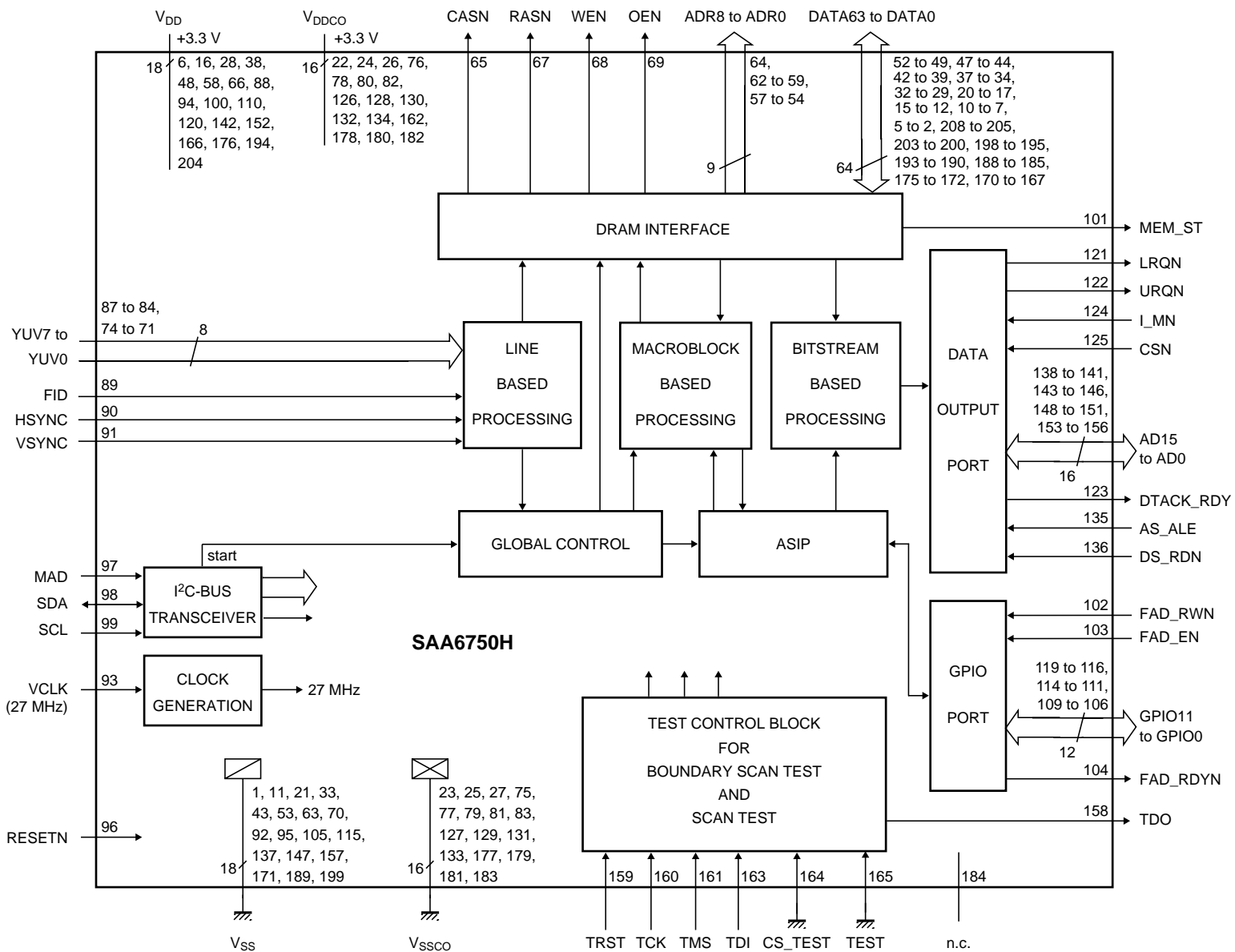

Fig.1 Block diagram.

Encoder for MPEG2 image recording  
(EMPIRE)

SAA6750H

## 6 PINNING

SYMBOL	PIN	INPUT/OUTPUT <sup>(1)</sup>	I <sub>max</sub> (mA)	DESCRIPTION
V <sub>SS</sub>	1	ground	–	ground for pad ring
DATA28	2	input/output	3	DRAM data interface bit 28
DATA29	3	input/output	3	DRAM data interface bit 29
DATA30	4	input/output	3	DRAM data interface bit 30
DATA31	5	input/output	3	DRAM data interface bit 31
V <sub>DD</sub>	6	supply	–	supply voltage for pad ring
DATA32	7	input/output	3	DRAM data interface bit 32
DATA33	8	input/output	3	DRAM data interface bit 33
DATA34	9	input/output	3	DRAM data interface bit 34
DATA35	10	input/output	3	DRAM data interface bit 35
V <sub>SS</sub>	11	ground	–	ground for pad ring
DATA36	12	input/output	3	DRAM data interface bit 36
DATA37	13	input/output	3	DRAM data interface bit 37
DATA38	14	input/output	3	DRAM data interface bit 38
DATA39	15	input/output	3	DRAM data interface bit 39
V <sub>DD</sub>	16	supply	–	supply voltage for pad ring
DATA40	17	input/output	3	DRAM data interface bit 40
DATA41	18	input/output	3	DRAM data interface bit 41
DATA42	19	input/output	3	DRAM data interface bit 42
DATA43	20	input/output	3	DRAM data interface bit 43
V <sub>SS</sub>	21	ground	–	ground for pad ring
V <sub>DCCO</sub>	22	supply	–	supply voltage for core logic
V <sub>SSCO</sub>	23	ground	–	ground for core logic
V <sub>DCCO</sub>	24	supply	–	supply voltage for core logic
V <sub>SSCO</sub>	25	ground	–	ground for core logic
V <sub>DCCO</sub>	26	supply	–	supply voltage for core logic
V <sub>SSCO</sub>	27	ground	–	ground for core logic
V <sub>DD</sub>	28	supply	–	supply voltage for pad ring
DATA44	29	input/output	3	DRAM data interface bit 44
DATA45	30	input/output	3	DRAM data interface bit 45
DATA46	31	input/output	3	DRAM data interface bit 46
DATA47	32	input/output	3	DRAM data interface bit 47
V <sub>SS</sub>	33	ground	–	ground for pad ring
DATA48	34	input/output	3	DRAM data interface bit 48
DATA49	35	input/output	3	DRAM data interface bit 49
DATA50	36	input/output	3	DRAM data interface bit 50
DATA51	37	input/output	3	DRAM data interface bit 51
V <sub>DD</sub>	38	supply	–	supply voltage for pad ring
DATA52	39	input/output	3	DRAM data interface bit 52

## Encoder for MPEG2 image recording (EMPIRE)

SAA6750H

SYMBOL	PIN	INPUT/OUTPUT <sup>(1)</sup>	I <sub>max</sub> (mA)	DESCRIPTION
DATA53	40	input/output	3	DRAM data interface bit 53
DATA54	41	input/output	3	DRAM data interface bit 54
DATA55	42	input/output	3	DRAM data interface bit 55
V <sub>SS</sub>	43	ground	–	ground for pad ring
DATA56	44	input/output	3	DRAM data interface bit 56
DATA57	45	input/output	3	DRAM data interface bit 57
DATA58	46	input/output	3	DRAM data interface bit 58
DATA59	47	input/output	3	DRAM data interface bit 59
V <sub>DD</sub>	48	supply	–	supply voltage for pad ring
DATA60	49	input/output	3	DRAM data interface bit 60
DATA61	50	input/output	3	DRAM data interface bit 61
DATA62	51	input/output	3	DRAM data interface bit 62
DATA63	52	input/output	3	DRAM data interface bit 63 (MSB)
V <sub>SS</sub>	53	ground	–	ground for pad ring
ADR0	54	output/3-state	3	DRAM address interface bit 0 (LSB)
ADR1	55	output/3-state	3	DRAM address interface bit 1
ADR2	56	output/3-state	3	DRAM address interface bit 2
ADR3	57	output/3-state	3	DRAM address interface bit 3
V <sub>DD</sub>	58	supply	–	supply voltage for pad ring
ADR4	59	output/3-state	3	DRAM address interface bit 4
ADR5	60	output/3-state	3	DRAM address interface bit 5
ADR6	61	output/3-state	3	DRAM address interface bit 6
ADR7	62	output/3-state	3	DRAM address interface bit 7
V <sub>SS</sub>	63	ground	–	ground for pad ring
ADR8	64	output/3-state	3	DRAM address interface bit 8 (MSB)
CASN	65	output/3-state	6	DRAM column address strobe (active LOW)
V <sub>DD</sub>	66	supply	–	supply voltage for pad ring
RASN	67	output/3-state	3	DRAM row address strobe (active LOW)
WEN	68	output/3-state	3	DRAM write enable (active LOW)
OEN	69	output/3-state	3	DRAM chip select (active LOW)
V <sub>SS</sub>	70	ground	–	ground for pad ring
YUV0	71	input	–	video input signal bit 0 (LSB)
YUV1	72	input	–	video input signal bit 1
YUV2	73	input	–	video input signal bit 2
YUV3	74	input	–	video input signal bit 3
V <sub>SSCO</sub>	75	ground	–	ground for core logic
V <sub>DDCO</sub>	76	supply	–	supply voltage for core logic
V <sub>SSCO</sub>	77	ground	–	ground for core logic
V <sub>DDCO</sub>	78	supply	–	supply voltage for core logic
V <sub>SSCO</sub>	79	ground	–	ground for core logic



Encoder for MPEG2 image recording  
(EMPIRE)

SAA6750H

SYMBOL	PIN	INPUT/OUTPUT <sup>(1)</sup>	I <sub>max</sub> (mA)	DESCRIPTION
V <sub>DDCO</sub>	80	supply	–	supply voltage for core logic
V <sub>SSCO</sub>	81	ground	–	ground for core logic
V <sub>DDCO</sub>	82	supply	–	supply voltage for core logic
V <sub>SSCO</sub>	83	ground	–	ground for core logic
YUV4	84	input	–	video input signal bit 4
YUV5	85	input	–	video input signal bit 5
YUV6	86	input	–	video input signal bit 6
YUV7	87	input	–	video input signal bit 7 (MSB)
V <sub>DD</sub>	88	supply	–	supply voltage for pad ring
FID	89	input	–	odd/even field identification
HSYNC	90	input	–	horizontal reference signal
VSYNC	91	input	–	vertical reference signal
V <sub>SS</sub>	92	ground	–	ground for pad ring
VCLK	93	input	–	video clock input (27 MHz)
V <sub>DD</sub>	94	supply	–	supply voltage for pad ring
V <sub>SS</sub>	95	ground	–	ground for pad ring
RESETN	96	input	–	hard reset input (active LOW)
MAD	97	input	–	module address (I <sup>2</sup> C-bus)
SDA	98	input/open drain output	6	serial data input/output (I <sup>2</sup> C-bus)
SCL	99	input/open drain output	–	serial clock input (I <sup>2</sup> C-bus)
V <sub>DD</sub>	100	supply	–	supply voltage for pad ring
MEM_ST	101	output/3-state	3	do not use in the application (reserved)
FAD_RWN	102	input	–	ASIP port data read/write
FAD_EN	103	input	–	ASIP port data enable
FAD_RDYN	104	open drain output	3	ASIP port data ready (active LOW)
V <sub>SS</sub>	105	ground	–	ground for pad ring
GPIO0	106	input/output	3	ASIP port data bit 0 (LSB)
GPIO1	107	input/output	3	ASIP port data bit 1
GPIO2	108	input/output	3	ASIP port data bit 2
GPIO3	109	input/output	3	ASIP port data bit 3
V <sub>DD</sub>	110	supply	–	supply voltage for pad ring
GPIO4	111	input/output	3	ASIP port data bit 4
GPIO5	112	input/output	3	ASIP port data bit 5
GPIO6	113	input/output	3	ASIP port data bit 6
GPIO7	114	input/output	3	ASIP port data bit 7
V <sub>SS</sub>	115	ground	–	ground for pad ring
GPIO8	116	input/output	3	ASIP port data bit 8
GPIO9	117	input/output	3	ASIP port data bit 9
GPIO10	118	input/output	3	ASIP port data bit 10
GPIO11	119	input/output	3	ASIP port data bit 11 (MSB)

# Encoder for MPEG2 image recording (EMPIRE)

SAA6750H

SYMBOL	PIN	INPUT/OUTPUT <sup>(1)</sup>	I <sub>max</sub> (mA)	DESCRIPTION
V <sub>DD</sub>	120	supply	–	supply voltage for pad ring
LRQN	121	open drain output	3	output port lower watermark interrupt request (active LOW)
URQN	122	open drain/3-state	3	output port upper watermark interrupt request (active LOW)
DTACK_RDY	123	open drain output	3	output port data transfer acknowledge/ready/request
I <sub>MN</sub>	124	input	–	output port Intel/Motorola bus style selection input (active LOW); with internal pull-up resistor
CSN	125	input	–	output port chip select for external address mode (active LOW); with internal pull-up resistor
V <sub>DDCO</sub>	126	supply	–	supply voltage for core logic
V <sub>SSCO</sub>	127	ground	–	ground for core logic
V <sub>DDCO</sub>	128	supply	–	supply voltage for core logic
V <sub>SSCO</sub>	129	ground	–	ground for core logic
V <sub>DDCO</sub>	130	supply	–	supply voltage for core logic
V <sub>SSCO</sub>	131	ground	–	ground for core logic
V <sub>DDCO</sub>	132	supply	–	supply voltage for core logic
V <sub>SSCO</sub>	133	ground	–	ground for core logic
V <sub>DDCO</sub>	134	supply	–	supply voltage for core logic
AS_ALE	135	input	–	output port address strobe/address latch enable
DS_RDN	136	input	–	output port data strobe/read
V <sub>SS</sub>	137	ground	–	ground for pad ring
AD15	138	input/output	3	output port multiplexed address/data line bit 15 (MSB)
AD14	139	input/output	3	output port multiplexed address/data line bit 14
AD13	140	input/output	3	output port multiplexed address/data line bit 13
AD12	141	input/output	3	output port multiplexed address/data line bit 12
V <sub>DD</sub>	142	supply	–	supply voltage for pad ring
AD11	143	input/output	3	output port multiplexed address/data line bit 11
AD10	144	input/output	3	output port multiplexed address/data line bit 10
AD9	145	input/output	3	output port multiplexed address/data line bit 9
AD8	146	input/output	3	output port multiplexed address/data line bit 8
V <sub>SS</sub>	147	ground	–	ground for pad ring
AD7	148	input/output	3	output port multiplexed address/data line bit 7/data bus bit 7 (MSB)
AD6	149	input/output	3	output port multiplexed address/data line bit 6/data bus bit 6
AD5	150	input/output	3	output port multiplexed address/data line bit 5/data bus bit 5
AD4	151	input/output	3	output port multiplexed address/data line bit 4/data bus bit 4
V <sub>DD</sub>	152	supply	–	supply voltage for pad ring
AD3	153	input/output	3	output port multiplexed address/data line bit 3/data bus bit 3
AD2	154	input/output	3	output port multiplexed address/data line bit 2/data bus bit 2
AD1	155	input/output	3	output port multiplexed address/data line bit 1/data bus bit 1
AD0	156	input/output	3	output port multiplexed address/data line bit 0 (LSB)/data bus bit 0 (LSB)

Encoder for MPEG2 image recording  
(EMPIRE)

SAA6750H

SYMBOL	PIN	INPUT/OUTPUT <sup>(1)</sup>	I <sub>max</sub> (mA)	DESCRIPTION
V <sub>SS</sub>	157	ground	–	ground for pad ring
TDO	158	output	3	boundary scan test data output; pin not active during normal operation; with 3-state output; note 2
TRST	159	input	–	boundary scan test reset; pin must be set to LOW for normal operation; with internal pull-up resistor; notes 2 and 3
TCK	160	input	–	boundary scan test clock; pin must be set to LOW during normal operation; with internal pull-up resistor; note 2
TMS	161	input	–	boundary scan test mode select; pin must float or set to HIGH during normal operation; with internal pull-up resistor; note 2
V <sub>DDCO</sub>	162	supply	–	supply voltage for core logic
TDI	163	input	–	boundary scan test data input; pin must float or set to HIGH during normal operation; with internal pull-up resistor; note 2
CS_TEST	164	input	–	test mode for the internal RAMs; pin must be set to LOW during normal operation
TEST	165	input	–	test mode; pin must be set to LOW during normal operation
V <sub>DD</sub>	166	supply	–	supply voltage for pad ring
DATA0	167	input/output	3	DRAM data interface bit 0 (LSB)
DATA1	168	input/output	3	DRAM data interface bit 1
DATA2	169	input/output	3	DRAM data interface bit 2
DATA3	170	input/output	3	DRAM data interface bit 3
V <sub>SS</sub>	171	ground	–	ground for pad ring
DATA4	172	input/output	3	DRAM data interface bit 4
DATA5	173	input/output	3	DRAM data interface bit 5
DATA6	174	input/output	3	DRAM data interface bit 6
DATA7	175	input/output	3	DRAM data interface bit 7
V <sub>DD</sub>	176	supply	–	supply voltage for pad ring
V <sub>SSCO</sub>	177	ground	–	ground for core logic
V <sub>DDCO</sub>	178	supply	–	supply voltage for core logic
V <sub>SSCO</sub>	179	ground	–	ground for core logic
V <sub>DDCO</sub>	180	supply	–	supply voltage for core logic
V <sub>SSCO</sub>	181	ground	–	ground for core logic
V <sub>DDCO</sub>	182	supply	–	supply voltage for core logic
V <sub>SSCO</sub>	183	ground	–	ground for core logic
n.c.	184	–	–	reserved pin; do not connect
DATA8	185	input/output	3	DRAM data interface bit 8
DATA9	186	input/output	3	DRAM data interface bit 9
DATA10	187	input/output	3	DRAM data interface bit 10
DATA11	188	input/output	3	DRAM data interface bit 11
V <sub>SS</sub>	189	ground	–	ground for pad ring
DATA12	190	input/output	3	DRAM data interface bit 12
DATA13	191	input/output	3	DRAM data interface bit 13

Encoder for MPEG2 image recording  
(EMPIRE)

SAA6750H

SYMBOL	PIN	INPUT/OUTPUT <sup>(1)</sup>	I <sub>max</sub> (mA)	DESCRIPTION
DATA14	192	input/output	3	DRAM data interface bit 14
DATA15	193	input/output	3	DRAM data interface bit 15
V <sub>DD</sub>	194	supply	–	supply voltage for pad ring
DATA16	195	input/output	3	DRAM data interface bit 16
DATA17	196	input/output	3	DRAM data interface bit 17
DATA18	197	input/output	3	DRAM data interface bit 18
DATA19	198	input/output	3	DRAM data interface bit 19
V <sub>SS</sub>	199	ground	–	ground for pad ring
DATA20	200	input/output	3	DRAM data interface bit 20
DATA21	201	input/output	3	DRAM data interface bit 21
DATA22	202	input/output	3	DRAM data interface bit 22
DATA23	203	input/output	3	DRAM data interface bit 23
V <sub>DD</sub>	204	supply	–	supply voltage for pad ring
DATA24	205	input/output	3	DRAM data interface bit 24
DATA25	206	input/output	3	DRAM data interface bit 25
DATA26	207	input/output	3	DRAM data interface bit 26
DATA27	208	input/output	3	DRAM data interface bit 27

**Notes**

- All input, I/O (in input mode), output (in 3-state mode) and open drain output pins are 5.0 V tolerant.
- In accordance with the "IEEE 1149.1" standard.
- Special functionality of pin TRST:
  - For board designs without boundary scan implementation, pin TRST must be connected to ground.
  - Pin TRST provides easy initialization of the internal BST circuit. By applying a LOW it can be used to force the internal Test Access Port (TAP) controller to the Test-Logic-Reset state (normal operation) at once.

The 208 pins are divided in following groups:

**Video input port (11 pins):**

- 8 data pins
- 3 control pins.

**Data output port (23 pins):**

- 16 data pins
- 7 control pins.

**GPIO port (15 pins):**

- 12 data pins
- 3 control pins.

**DRAM (77 pins):**

- 64 data pins
- 9 address pins
- 4 control pins.

**Others (14 pins):**

- 1 video clock input pin
- 3 pins related to the I<sup>2</sup>C-bus
- 1 pin for reset control
- 7 pins for test purposes
- 1 pin not connected
- 1 pin for internal test purposes.

**Supply (68 pins):**

- 16 core supply pins
- 18 I/O cell supply pins
- 16 core ground pins
- 18 I/O cell ground pins.

# Encoder for MPEG2 image recording (EMPIRE)

SAA6750H

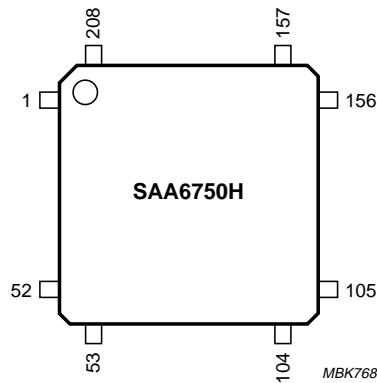

Fig.2 Pin configuration.

## 7 FUNCTIONAL DESCRIPTION

### 7.1 Global architecture description

#### 7.1.1 GENERAL

The SAA6750H has a multi-processor architecture. The different processing and control modules are not locked to each other but run independently within the limits of the global scheduling. The data transfer between the processing units is carried out via FIFO memories or the external DRAM (see Fig.1).

The set of functions of the SAA6750H is to a high extent determined by the microcode of the internal Application Specific Instruction-set Processor (ASIP). Detailed information is given in the software specification.

Global settings and selection of the operation modes are carried out via I<sup>2</sup>C-bus (see Sections 7.2 and 7.9).

#### 7.1.2 ARCHITECTURE STRUCTURE

The architecture consist of a data processing, a control and a memory part.

##### 7.1.2.1 Data processing part

The data processing flow can be split-up as follows:

#### Line based processing:

Video front-end and formatter (see Section 7.3) including:

1. 4 : 2 : 2 to 4 : 2 : 0 pre-filter
2. Optional SIF subsampling.

The video front-end processes the incoming video data and writes it to the external DRAM.

#### Macroblock based processing:

MacroBlock Processor (MBP) (see Section 7.4) including:

1. Discrete Cosine Transformation/Inverse Discrete Cosine Transformation (DCT/IDCT)
2. Variable Length Encoding/Run Length Encoding (VLE/RLE)
3. Motion Estimation/Motion Compensation (ME/MC)
4. Motion Compensation Noise Reduction (MCNR)
5. Quantization/Inverse Quantization (Q/IQ)
6. Frame/Field reshuffling and zigzag scan (FF, ZZ).

The MBP gets the pre-processed video data from the external DRAM and performs the data compression.

## Encoder for MPEG2 image recording (EMPIRE)

SAA6750H

### Bit-stream based processing:

Bit stream assembly (see Section 7.5) including:

1. Pre-packer
2. Packer
3. Stuffing unit and output buffer.

Data output port (see Section 7.6).

The bit-stream processing part gets the compressed data from the MBP and the header information from the control part. It provides an MPEG2 compliant elementary stream at the output.

#### 7.1.2.2 Control part

The control part consists of three modules:

1. Application Specific Instruction-set Processor (ASIP) (see Section 7.7); controls the MBP, generates motion vectors, headers and stuffing information.
2. The global controller (see Section 7.8); generates the global scheduling information for the MBP, the DRAM interface and the ASIP.
3. The I<sup>2</sup>C-bus interface and controller (see Section 7.9); download of ASIP microcode, tables and constants as well as MBP quantizer table, used for external control settings, allows communication between ASIP and application environment.

#### 7.1.2.3 Memory part

The control and data processing modules exchange data via internal FIFOs and the external DRAM:

1. DRAM interface (see Section 7.10); provides access to the external DRAM memory.
2. FIFO memories (see Section 7.11); a number of FIFOs of different size is used to connect internal processing units.

## 7.2 Start-up and operation modes

### 7.2.1 START-UP REQUIREMENTS

Simultaneously with power-on, the SAA6750H requires a LOW level at pin RESETN. This external reset has to be kept active until the external video clock signal VCLK has been running stable within the specified limits for at least 10 clock cycles (see Chapter "Quick reference data"). A suitable combination of RESETN and clock signal is e.g. provided by Philips product family SAA7111A. For proper reset behaviour and operation pin TRST has to be LOW.

After power on and the related internal reset the initialization via I<sup>2</sup>C-bus has to be carried out (see Section 7.9.5). It should be noted that a delay of at least 0.5 ms between the end of RESETN LOW state and start of the I<sup>2</sup>C-bus initialization sequence is required. See Table 1 for information about the operation modes.

### 7.2.2 RESET PROCESSING

The SAA6750H has internally an asynchronous and a synchronous reset processing.

The asynchronous reset is directly derived from the external reset signal RESETN and gets active as soon as RESETN becomes LOW. It is not depending on the external clock signal. The asynchronous reset forces the SAA6750H into reset mode which does directly affect the behaviour of the output and I/O pins (see Table 2). This does guarantee a defined state of the pins even if no clock signal is available. In addition it initiates the internal synchronous reset which gets active as soon as the VCLK signal is available.

The internal synchronous reset is controlled by RESETN and the settings of control bits E\_ST and E\_SP. For proper operation the external clock signal VCLK has to be stable within the specified limits.

The internal synchronous reset gets active if RESETN is LOW or by setting the control bits E\_ST and E\_SP to soft reset mode (see Table 1). It does affect all internal modules except the I<sup>2</sup>C-bus controller and therefore also the output and I/O pins (see Table 2). In addition, but only if combined with an external reset RESETN, it does reset the I<sup>2</sup>C-bus control register. It does not affect the contents of the embedded microcode and constant memories (see Section 7.9.4).

See Table 2 for detailed information about the impact of external and internal reset signals as well as control bit settings on the behaviour of internal modules and output pins.

After release of the external reset or setting back E\_ST and E\_SP to operation mode, the internal synchronous reset remains active for 7562 clock cycles (approximately 260  $\mu$ s). During this time the DRAM initialization sequence is carried out (see Section 7.10.3.2). All other internal modules except the I<sup>2</sup>C-bus control register stay in reset mode for this time. The external DRAM will not be refreshed during internal synchronous reset.

## Encoder for MPEG2 image recording (EMPIRE)

SAA6750H

### 7.2.3 DESCRIPTION OF OPERATION MODES

Depending on the reset processing and the setting of I<sup>2</sup>C-bus control bits E\_ST and E\_SP (see Tables 24 and 25) the SAA6750H can be set to different operation modes. Purpose and behaviour are described in Table 1.

After an external reset pulse at RESETN, the init mode will be active because control bits E\_ST and E\_SP are set to LOW.

### 7.2.4 PIN BEHAVIOUR

The behaviour of I/O and output pins is depending on the operation mode of the SAA6750H. In reset mode the pins

are forced to a certain behaviour even if no clock VCLK is available. Reset mode overrules all other internal pin settings. During soft reset mode all output and I/O pins that could create driver conflicts with other devices are forced to 3-state or input mode. The internal reset is active during a period of 7562 clock cycles after reset mode and soft reset mode. The status of pins is determined by the reset behaviour of the internal modules. The internal reset behaviour applies also for the init mode because init mode always follows internal reset.

In operation mode the status of the pins is depending on the function of the SAA6750H.

**Table 1** SAA6750H operation modes

OPERATION MODE	ACTIVATED BY			DESCRIPTION
	RESETN	E_ST	E_SP	
Reset mode	0	X	X	In reset mode all I/O and output pins are forced to a defined state with RESETN = LOW (refer to Table 2). After VCLK is available, also the internal reset becomes active, which puts the internal modules in reset state. The I <sup>2</sup> C-bus control register is cleared in this mode. After setting RESETN back to HIGH, the internal reset will remain active for 7562 clock cycles. The DRAM initialization sequence will run during this time (see Section 7.10.3.2).
Init mode	1	0	0	In init mode the device initialization via I <sup>2</sup> C-bus has to be performed. The external DRAM is not refreshed. See Table 2 for behaviour of pins during init mode. This mode will be active after external reset due to reset of E_ST and E_SP. Remark: Do not switch from operation mode to init mode directly. Always use the soft reset or reset mode as intermediate step.
Soft reset mode	1	0	1	Activates the internal synchronous reset. All internal modules except the I <sup>2</sup> C-bus control register are in reset mode. This mode allows e.g. operation of a second device SAA6750H. Therefore output and I/O pins are in input or 3-state mode (see Table 2). The external DRAM will not be refreshed. After setting E_SP back to LOW, the internal reset will remain active for 7562 clock cycles. The DRAM initialization sequence will run during this time (see Section 7.10.3.2).
Operation mode	1	1	0	Normal operation.
–	1	1	1	Internal use only.

# Encoder for MPEG2 image recording (EMPIRE)

SAA6750H

**Table 2** Behaviour of output and I/O pins

PIN NAME	DESCRIPTION	PIN STATUS		
		RESET MODE	INIT MODE & INTERNAL RESET	SOFT RESET MODE
DATA0 to DATA63	DRAM data input/output	input	input	input
ADR0 to ADR8	DRAM address output	3-state	output	3-state
CASN	DRAM column address strobe output	3-state	output	3-state
RASN	DRAM row address strobe output	3-state	output	3-state
WEN	DRAM write enable output	3-state	output	3-state
OEN	DRAM chip select output	3-state	output	3-state
SDA	I <sup>2</sup> C-bus data input/open drain output	input	normal operation	normal operation
SCL	I <sup>2</sup> C-bus clock input/output	input	normal operation	normal operation
MEM_ST	reserved output	3-state	output	3-state
FAD_RDYN	ASIP data port; data ready output	open drain; note 1	open drain	open drain
GPIO0 to GPIO11	ASIP data port; input/output	input	input	input
LRQN	output port lower watermark interrupt request	open drain	on	open drain
URQN	output port upper watermark interrupt request	open drain	on	open drain
DTACK_RDY	output port data transfer acknowledge/ready/request	open drain	on	open drain
AD0 to AD15	output port address/data input/output	input	input	input

**Note**

1. Only defined if external clock is available.

**7.3 Video front-end and formatter****7.3.1 GENERAL**

The video front-end and formatter module consists of an 8-bit data input interface, a formatter sub-module and a luminance and a chrominance address processing unit. The interface is designed for use with Philips SAA7111 video decoder family or similar foreign products. The input interface accepts a digital video input stream according to "ITU-T 601". PAL standard at 50 Hz and 720 pixel by 576 lines as well as NTSC at 60 Hz and 720 pixel by 480 lines are covered. The video synchronization may either follow "ITU-T 656" recommendation or can also be supplied by external signals (HSYNC, VSYNC and FID). The formatter module performs a colour conversion from 4 : 2 : 2 to 4 : 2 : 0 format. Optionally, also an SIF down-scaling may be activated for PAL as well as NTSC standard signals. The luminance and chrominance processing units do generate the addresses for storing the front-end output data in the external DRAM memory.

**7.3.2 DATA INPUT FORMAT**

The 8-bit video input data has to be transferred at a frequency of 27 Mwords/s (13.5 MHz for luminance and 6.25 MHz for both chrominance components) i.e. one data word per clock cycle has to be sent. The elements of a data stream have the following order: C<sub>B</sub>, Y, C<sub>R</sub>, Y, C<sub>B</sub>, Y, C<sub>R</sub>, Y, etc. The byte combinations 00H and FFH are reserved for synchronization purposes, so that only a subset of 254 of all possible 2<sup>8</sup> = 256 combinations are used. See Section 7.3.3 for detailed information about the synchronization signals.

The external reference clock VCLK has to be synchronized to the video input data.



## Encoder for MPEG2 image recording (EMPIRE)

SAA6750H

### 7.3.3 FUNCTIONAL DESCRIPTION

#### 7.3.3.1 General

The video front-end and formatter module consists of four submodules:

1. The 8-bit data interface and the related control signals connect the SAA6750H to external data sources like e.g. Philips SAA711x product family.
2. The formatter submodule covers two main functions: The processing of the synchronization information (sync processing) and the processing of the picture contents (line based processing).
3. The luminance and chrominance submodules generate the addresses in the external DRAM memory where the output data of the video front-end and formatter module is stored.

The video front-end and formatter module offers various operation modes. The appropriate setting can be selected in the I<sup>2</sup>C-bus control register (see Tables 1 and 24). It should be noted that changes of video standard or synchronization settings are only allowed in init mode or soft reset mode. See Section 7.2.3 for information of the operation modes.

**Table 3** Video front-end and formatter mode selection

CONTROL BITS <sup>(1)</sup>			MODE	FUNCTION
STD	SS	SMOD		
0	0	X	NTSC	NTSC input signal processing (60 Hz and 720 pixel by 480 lines).
1	0	X	PAL	PAL input signal processing (50 Hz and 720 pixel by 576 lines).
0	1	X	NTSC-SIF	NTSC input signal processing (60 Hz and 720 pixel by 480 lines). SIF down-scaling active.
1	1	X	PAL-SIF	PAL input signal processing (50 Hz and 720 pixel by 576 lines). SIF down-scaling active.
X	X	0	ITU-T 656	ITU-T 656 mode sync processing mode. Sync information is embedded in the video data input stream.
X	X	1	external sync	External sync processing mode. Sync information is provided via pins FID, HSYNC and VSYNC.

#### Note

1. Changes of video standard or synchronization setup settings are only allowed in init mode or soft reset mode. X = don't care. See Section 7.2.3 for information of the SAA6750H operation modes.

## Encoder for MPEG2 image recording (EMPIRE)

SAA6750H

### 7.3.3.2 Interface definition

The data input interface uses in total 11 pins. Pins YUV0 to YUV7 carry video and synchronization data. 3 pins are reserved for control purposes (see Table 4).

**Table 4** List of pins data input port

PIN NAME	PIN TYPE	DESCRIPTION
YUV0 to YUV7	input	video input signal (synchronous to VCLK)
FID	input	odd/even field identification signal; note 1
HSYNC	input	horizontal synchronization signal; note 1
VSYNC	input	vertical synchronization signal; note 1

#### Note

- In ITU-T 656 mode sync signals are embedded in the video data input stream. The external sync signals are not used.

### 7.3.3.3 Line based processing

The line based processing works the same way for PAL and NTSC signals.

Each of the three components of the video signals Y, U and V, are filtered horizontally. The filter is symmetrical and has seven taps. The seven taps are weighted with three programmable parameters a1, a2 and a3 as shown in Table 5.

**Table 5** Horizontal filtering

TAP	-3	-2	-1	0	1	2	3
Horizontal filtering $f(a1, a2, a3)$	a3	a2	a1	$1 - 2(a1 + a2 + a3)$	a1	a2	a3

The three parameters must be loaded by setting the I<sup>2</sup>C-bus control register words A1, A2 and A3. The valid range is 0 to 255. Reset state is 0.

To convert the video signal from 4 : 2 : 2 to 4 : 2 : 0 format, vertical filtering and subsampling of the chrominance components has to be performed. The vertical filter has six taps. The filter coefficients are given in Table 6.

**Table 6** Vertical filtering

TAP	1	2	3	4	5	6
Vertical filtering top fields	-3	13	30	24	4	-4
Vertical filtering bottom fields	-4	4	24	30	13	-3

As mentioned, optionally an SIF mode conversion of PAL or NTSC standard input signals may be activated by setting the I<sup>2</sup>C-bus control bit SS (see Tables 1 and 24). To convert the video signal to SIF resolution the bottom fields are discarded. Furthermore, all components of the video signal are horizontally subsampled by factor two.

## Encoder for MPEG2 image recording (EMPIRE)

SAA6750H

### 7.3.3.4 Sync processing

Because the synchronization information may be delivered by a video data source in two different ways, the internal sync processing of the SAA6750H is carried out in two related modes:

1. The ITU-T 656 mode.

The ITU-T 656 recommendation describes the unidirectional interconnection between a video data source and a video data sink. Luminance and chrominance data as well as the complete set of control data (V-sync, H-sync, field indication or byte information like SAV, EAV, etc.) are transferred interleaved on one 8-bit bus. Both, sync and data signal, are in the form of binary coded 8-bit words. The external sync signals HSYNC, VSYNC and FID are not used.

2. The external sync mode.

The synchronization may also be provided via pins HSYNC, VSYNC and FID. In this case, the 8-bit bus carries only the video data information.

The internal sync processing mode may be selected by the I<sup>2</sup>C-bus control bit SMOD (see Tables 1 and 24).

Sync signals must be active at regular time intervals. If a time interval is too short, a sync is skipped. Top and bottom fields must follow each other. If two top fields or two bottom fields follow each other immediately, then the second field is skipped.

The number of clock cycles and H-sync signals that have to occur before processing starts (horizontal and vertical shift) can be set via I<sup>2</sup>C-bus. In this way the active part of the video can be determined. The vertical shift can be specified independently for top and bottom fields by using the control words VERTICAL SHIFT TOP FIELD and VERTICAL SHIFT BOTTOM FIELD (see Table 24). The horizontal shift is controlled by control word HORIZONTAL SHIFT. The shift can be programmed in a range of 127 clock cycles in horizontal direction respectively 127 lines in vertical direction. Horizontal shift should be carried out in steps of a multiple of 4 because a minimum data sequence (C<sub>B</sub>, Y, C<sub>R</sub>, Y) needs 4 clock cycles. It should be noted that the horizontal blanking in PAL mode takes 280 clock cycles and in NTSC mode 268 cycles.

Due to the fact that the horizontal offset value can not compensate the whole blanking interval, the polarity of the three external sync lines (H-SYNC, V-SYNC and FID) can also be adapted via I<sup>2</sup>C-bus. Control bits HREFP, VREFP and FIDP are used for this purpose (see Table 24).

Internally, the edge-detection circuitries for these signals change polarity with these settings. By this way different synchronization schemes are supported. The horizontal respectively vertical processing starts with the selected edge.

Due to requirements from the internal vertical filtering the line based processing needs 3 horizontal sync pulses during vertical blanking which have to follow directly the active part of the frame (e.g. 288 active lines in PAL mode). The related line data is not processed. This restriction does not allow edge selection at the end of the previous field [e.g. vertical sync of line 623 or line 1 (see Fig.3)]. In this case the polarity bit VREFP has to be set, to select the falling edge of the sync lines.

The Sections 7.3.3.5, 7.3.3.6 and 7.3.3.7 as well as the related Section 7.3.3.8 contain descriptions of different styles of synchronization signals and how they are handled in the SAA6750H.

### 7.3.3.5 Sync processing PAL (50 Hz)

The PAL (50 Hz) input signal has 625 lines per frame and typically takes 1728 clock cycles per line. The minimum number of clock cycles per line is 1706. The active part of a field consists of 288 lines of 720 pixels (see Fig.7).

Figures 3 and 4 and the related Table 7 give an example illustrating how different sources providing different external sync signals can be adapted to the SAA6750H. In the given example, the SAA711x is connected to pins HSYNC, VSYNC and FID and provides external sync signals in two different modes: according to the timing convention of the ITU-T 656 mode and in a SAA711x proprietary format. In addition, another mode, HREF/VREF, is mentioned in Table 7. From timing point of view the HREF/VREF mode behaves like ITU-T 656, but signals horizontal sync and vertical sync (VSYNC) are inverted. See data sheet SAA7111A for detailed information.

As mentioned, in addition to the external sync mode, the ITU-T 656 mode is supported. Sections 7.3.3.7, 7.3.3.8 and Figs 7 and 8 contain detailed information on this sync mode.

# Encoder for MPEG2 image recording (EMPIRE)

SAA6750H

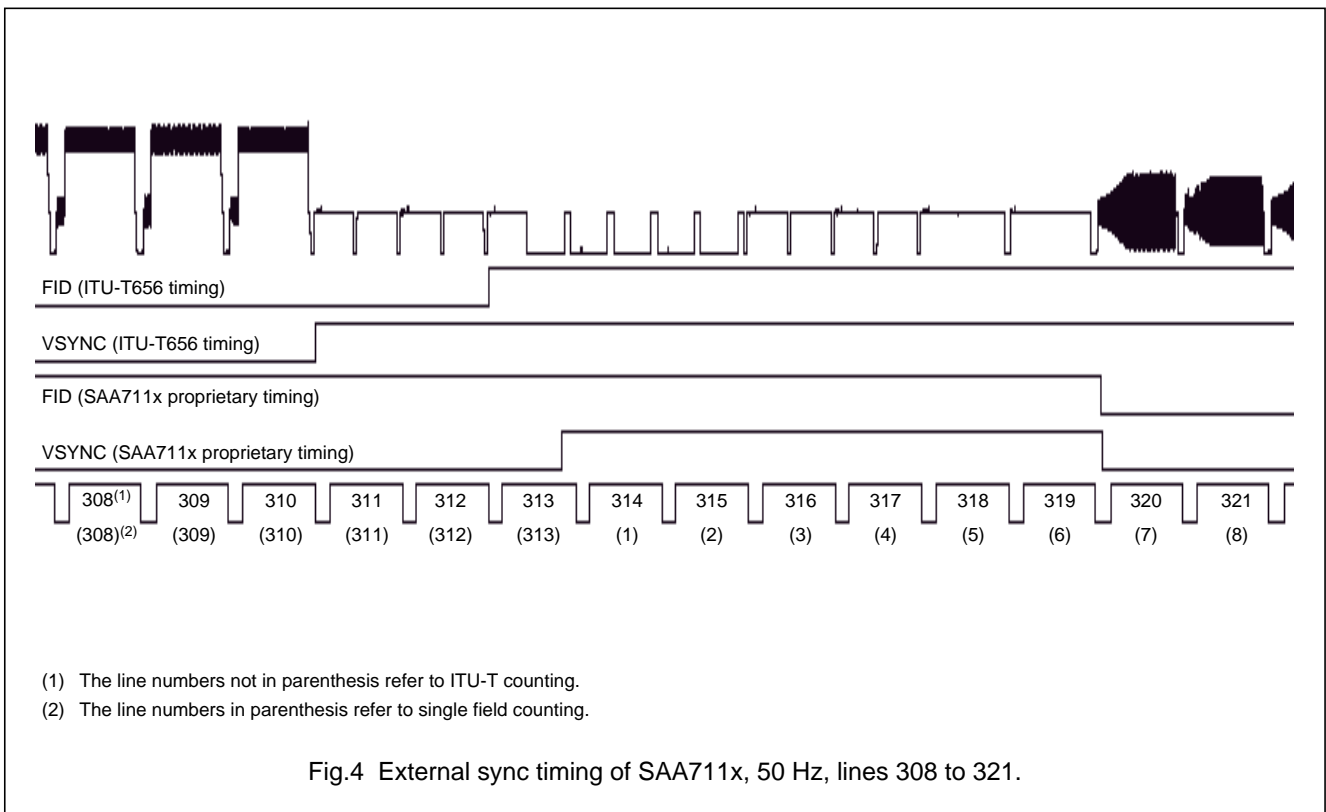
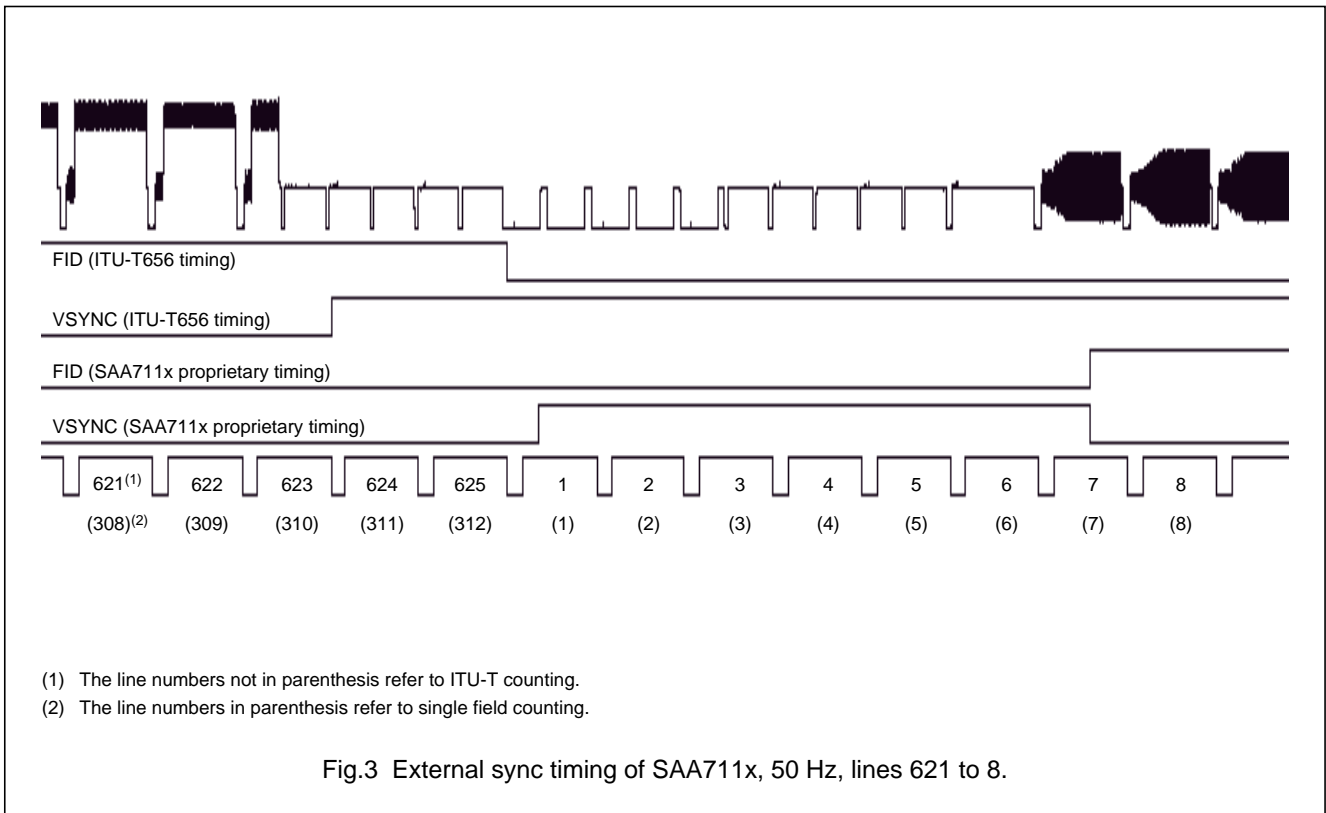

Encoder for MPEG2 image recording  
(EMPIRE)

SAA6750H

**Table 7** PAL mode programming example for different sync modes and timing schemes

PAL SYNC MODE AND TIMING	CONTROL BIT AND CONTROL WORD SETTINGS <sup>(1)</sup>						
	SMOD	FIDP	VREFP	HREFP	VERTICAL SHIFT TOP FIELD	VERTICAL SHIFT BOTTOM FIELD	HORIZONTAL SHIFT
ITU-T 656 mode	0	0	0	0	0	0	0
External sync mode; VREF/HREF mode input signals; ITU-T 656 timing; note 2	1	0	0	0	0	0	0
External sync mode; ITU-T 656 timing; note 3	1	0	1	1	0	0	0
External sync mode; SAA711x proprietary timing; note 3	1	0	1	1	15	16	0

**Notes**

- Changes of video standard or synchronization setup settings are only allowed in init mode or soft reset mode. See Section 7.2.3 for information of the SAA6750H operation modes.
- See the SAA711x documentation.
- As illustrated in Figs 3 and 4.

**7.3.3.6 Sync processing NTSC (60 Hz  $\approx$  59.94 Hz)**

This NTSC (60 Hz) input signal has 525 lines per frame and typically takes 1716 clock cycles per line. The minimum number of clock cycles per line is 1706. The active part of a field consists of 240 lines of 720 pixels (see Fig.9).

Figures 5 and 6 and the related Table 8 give an example illustrating how different sources providing different external sync signals can be adapted to the SAA6750H. In the given example, the SAA711x is connected to SAA6750H's pins HSYNC, VSYNC and FID and provides external sync signals in two different modes: according to

the timing convention of the ITU-T 656 mode and in an SAA711x proprietary format. In addition, another mode, HREF/VREF, is mentioned in Table 7. From timing point of view the HREF/VREF mode behaves like ITU-T 656, but signals horizontal sync and vertical sync (VSYNC) are inverted. See data sheet SAA7111A for detailed information.

As mentioned, in addition to the external sync mode, the ITU-T 656 mode is supported. Sections 7.3.3.7 and 7.3.3.8 and Figs 9 and 10 contain detailed information on this sync mode.

# Encoder for MPEG2 image recording (EMPIRE)

SAA6750H

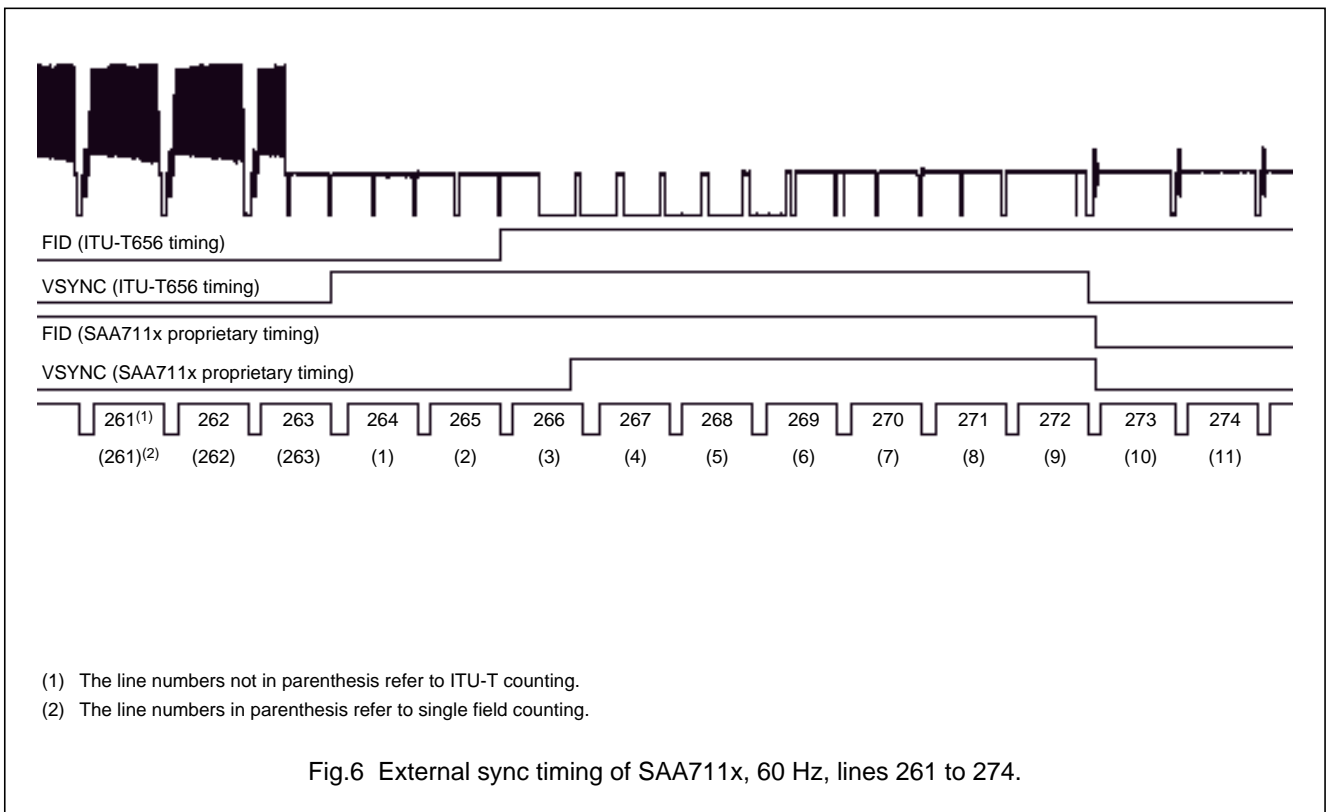
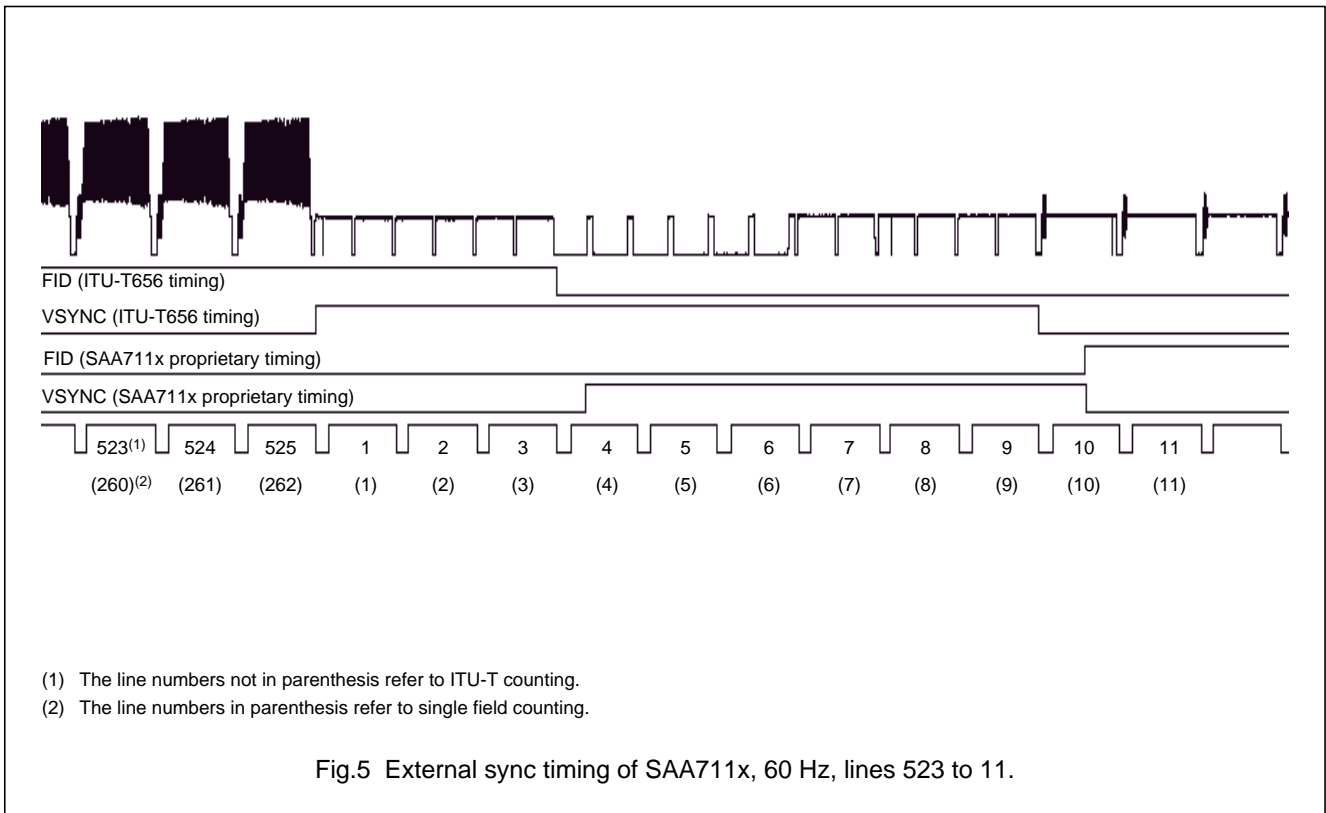

# Encoder for MPEG2 image recording (EMPIRE)

SAA6750H

**Table 8** NTSC mode programming example for different sync modes and timing schemes

NTSC SYNC MODE AND TIMING	CONTROL BIT AND CONTROL WORD SETTINGS <sup>(1)</sup>						
	SMOD	FIDP	VREFP	HREFP	VERTICAL SHIFT TOP FIELD	VERTICAL SHIFT BOTTOM FIELD	HORIZONTAL SHIFT
ITU-T 656 mode	0	0	0	0	0	0	0
External sync mode; VREF/HREF mode input signals; ITU-T 656 timing; note 2	1	0	0	0	0	0	0
External sync mode; ITU-T 656 timing; note 3	1	0	1	1	0	0	0
External sync mode; SAA711x proprietary timing; note 3	1	0	1	1	9	10	0

**Notes**

- Changes of video standard or synchronization setup settings are only allowed in init mode or soft reset mode. See Section 7.2.3 for information of the SAA6750H operation modes.
- See data sheet SAA711x documentation.
- As illustrated in Figs 5 and 6.

7.3.3.7 Sync processing coding characteristics according to "ITU-T 656"

The video data and the control data H\_sync, V\_sync and field identification are interleaved as follows:

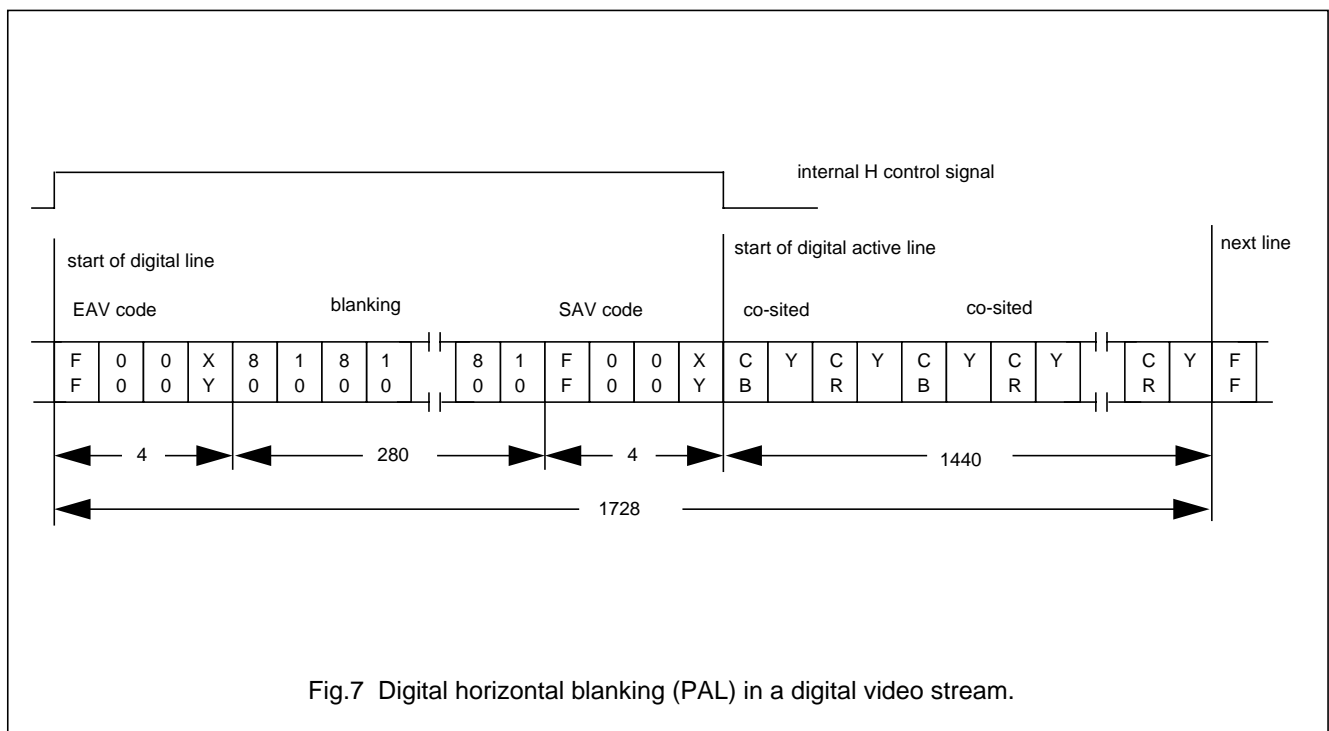
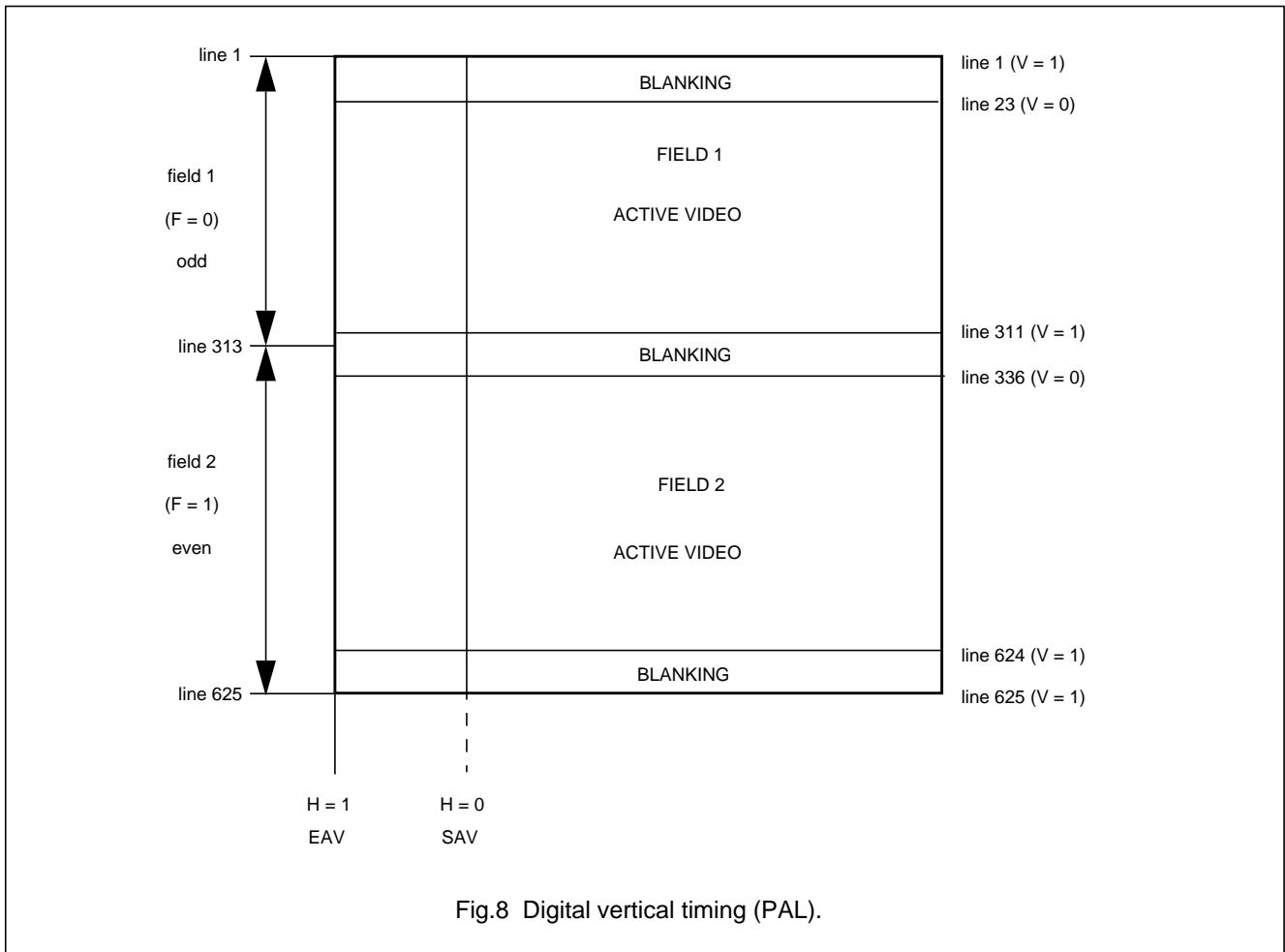

Fig.7 Digital horizontal blanking (PAL) in a digital video stream.

Encoder for MPEG2 image recording  
(EMPIRE)

SAA6750H



**Table 9** Digital vertical timing (PAL)

LINE NUMBER	F	V	H (EAV)	H (SAV)
1 to 22	0	1	1	0
23 to 310	0	0	1	0
311 and 312	0	1	1	0
313 to 335	1	1	1	0
336 to 623	1	0	1	0
624 and 625	1	1	1	0



# Encoder for MPEG2 image recording (EMPIRE)

SAA6750H

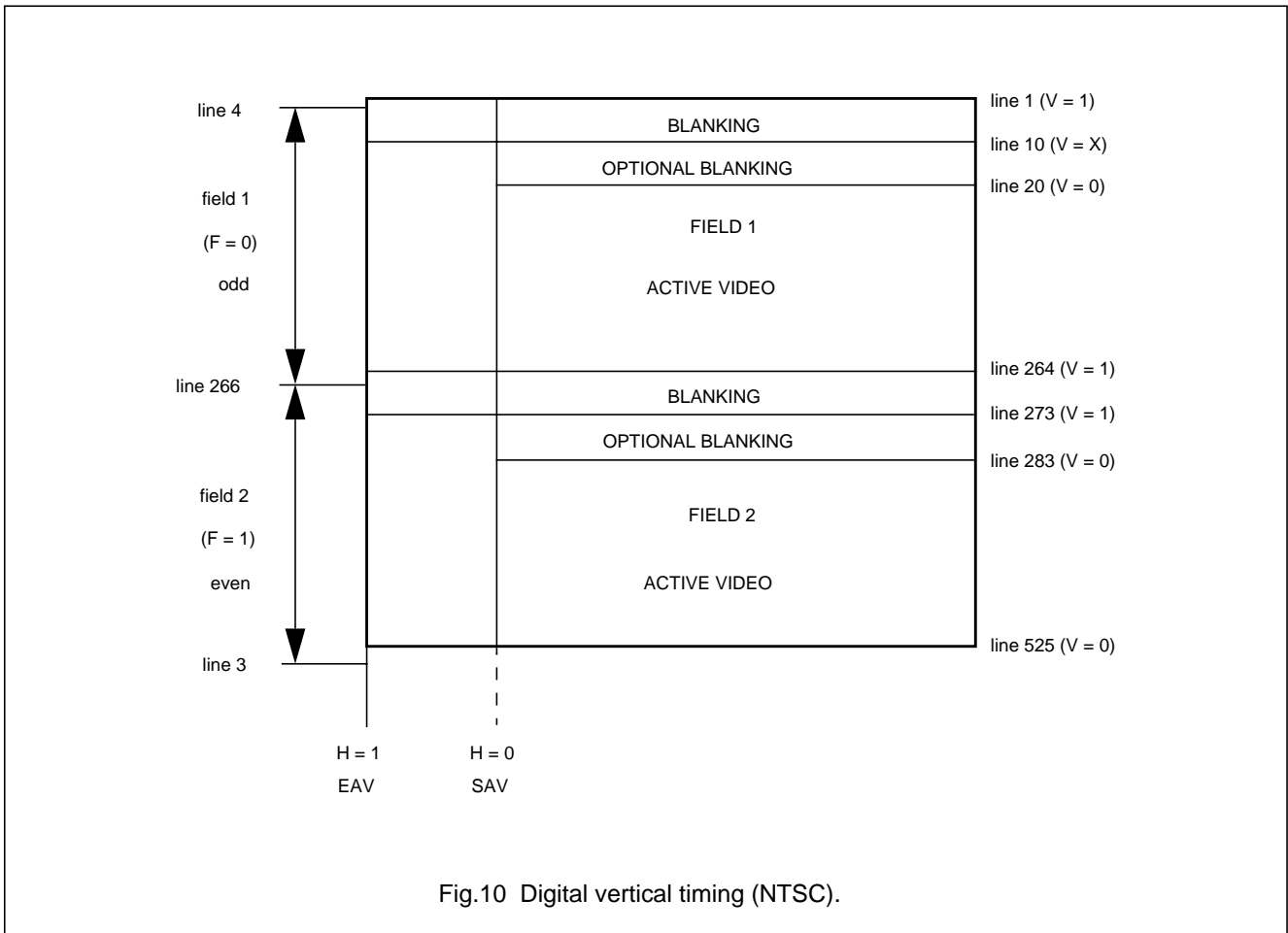
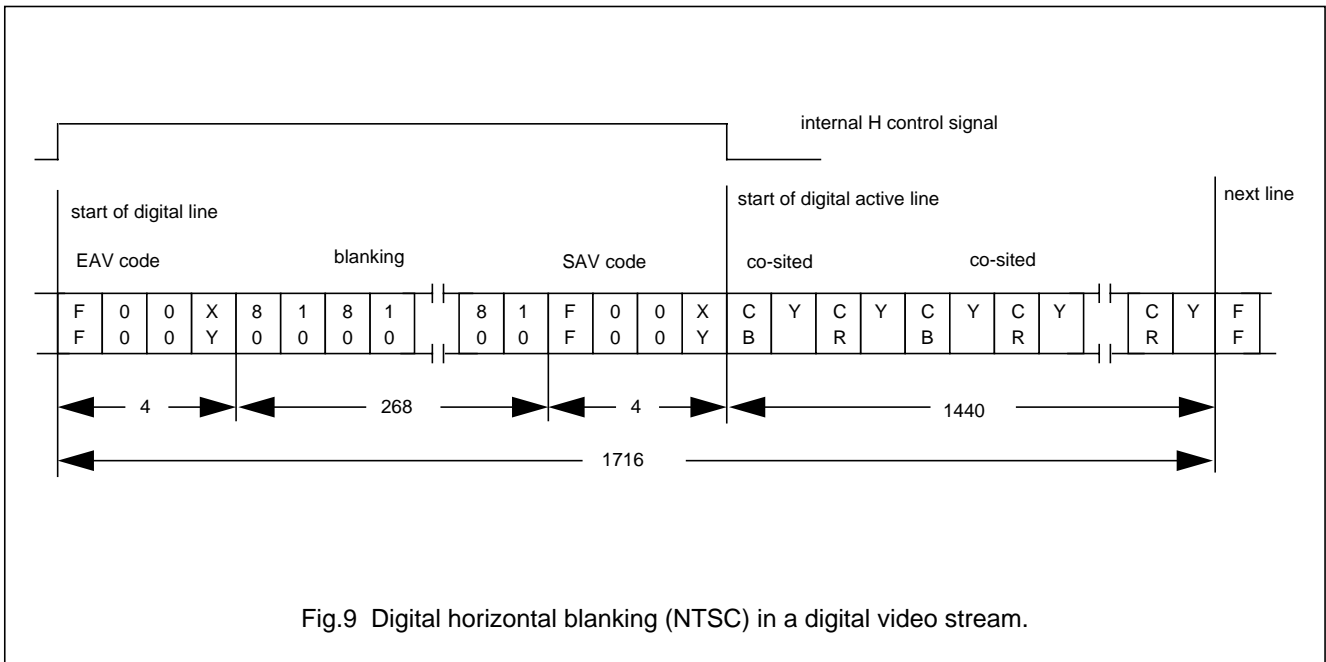

# Encoder for MPEG2 image recording (EMPIRE)

SAA6750H

**Table 10** Digital vertical timing (NTSC)

LINE NUMBER	F	V	H (EAV)	H (SAV)
1 to 3	1	1	1	0
4 to 19	0	1	1	0
20 to 263	0	0	1	0
264 and 265	0	1	1	0
266 to 282	1	1	1	0
283 to 525	1	0	1	0

### 7.3.3.8 Video timing reference codes (ITU-T 656)

There are two timing reference signals, one at the beginning of each video data block (start of active video, SAV) and one at the end of each video data block (end of active video, EAV).

Each timing reference signal consists of a four word sequence in the following format: FF 00 00 XY (values are expressed in hexadecimal notation). The first three words are a fixed preamble. The fourth word XY contains information defining field 2 identification, the state of field blanking, and the state of line blanking. The assignment of bits within the timing reference signal is shown in Table 11.

**Table 11** Video timing reference codes

1	F <sup>(1)</sup>	V <sup>(2)</sup>	H <sup>(3)</sup>	P <sub>3</sub> <sup>(4)</sup>	P <sub>2</sub> <sup>(4)</sup>	P <sub>1</sub> <sup>(4)</sup>	P <sub>0</sub> <sup>(4)</sup>

#### Notes

1. F = 0 during field 1; F = 1 during field 2.
2. V = 1 during field blanking; V = 0 elsewhere.
3. H = 0 in SAV; H = 1 in EAV.
4. Protection bits are ignored by SAA6750H data processing.

## 7.4 MacroBlock Processor (MBP)

### 7.4.1 GENERAL

The MacroBlock Processor (MBP) performs the compression of macroblocks. It fetches its input data from the external DRAM memory where this was stored by the video front-end and formatter. The data processing is macroblock related. The processing start information and the global scheduling is provided by the global controller module.

The functionality of the MBP is controlled by the Application Specific Instruction-set Processor (ASIP). The ASIP does also perform some computing of data needed by the MBP. The compressed data is fed to the packer module.

### 7.4.2 FUNCTIONAL DESCRIPTION

#### 7.4.2.1 General

The MBP performs source coding on macroblock level. It contains several items: Motion estimation; motion compensation, noise reduction and frame field conversion; Discrete and Inverse Discrete Cosine Transformations (DCT and IDCT), quantization and inverse quantization; motion decompensation and frame-field conversion; zigzag scanning; DC trend removal (residue); Run-Length Encoding and Variable-Length Encoding (RLE and VLE).

#### 7.4.2.2 Motion estimation

The motion estimator considers frame based motion. Furthermore, the frame distance is one frame and, consequently, can only be used for P frames.

The motion estimation is based on the recursive block matching algorithm. Per macroblock the ASIP must feed the motion estimator with five candidate vectors. Depending on a control word, the last two vectors can be relative to the computed vector of the previous macroblock or can be absolute. The vectors are compared by the Minimum Absolute Difference (MAD) of the estimated macroblock in the previous frame and the current macroblock. The vector that leads to the smallest MAD is selected. The fifth vector gets a penalty and can be used as random vector candidate. The two coordinates of the selected vector and the corresponding MAD value are returned to the ASIP.

#### 7.4.2.3 Noise filtering

The availability of the motion estimator makes motion compensated adaptive temporal filtering possible. The functioning of this filter can be programmed by two parameters. These parameters are provided by the ASIP.

The noise reduction may only be activated if control bit INTRA is set to LOW (see Table 24).

## Encoder for MPEG2 image recording (EMPIRE)

SAA6750H

### 7.4.2.4 *Intra/inter coded macroblock selection in P frames*

The selection of intra or inter coded macroblock compression mode depends on a control byte from the ASIP or on the MAD value. A macroblock is coded intra, if the ASIP demands so or when the MAD resulting from the motion estimation is above a threshold value. This threshold value is provided by the ASIP. The resulting encoding mode is returned to the ASIP.

### 7.4.2.5 *Field/frame DCT coded macroblock selection for luminance blocks*

Depending on motion between the two fields comprising a frame, the four  $8 \times 8$  pixel DCT luminance blocks of a macroblock are differently derived from the  $16 \times 16$  pixels. The luminance pixels of a macroblock are vertically Walsh-Hadamard transformed in order to detect the field motion. If the first coefficient is higher than a threshold value, then the DCT is performed field-wise. The ASIP can force frame DCT coding. The result, i.e. frame or field DCT coding, is returned to the ASIP. The output of the DCT are four luminance and two chrominance blocks consisting of  $8 \times 8$  pixels each.

### 7.4.2.6 *Quantization*

The quantization performs the redundancy removal, dependant on settings provided by the ASIP.

The quantization may be customized by using a dedicated quantization table which can be loaded via I<sup>2</sup>C-bus (see Section 7.9.4). The quantization table data is part of the software packages and will be described in the software specification.

### 7.4.2.7 *Trend removal*

DC coefficients are coded differentially. However, at the start of every slice and for every intra coded macroblock, the absolute values are coded. Therefore, the ASIP sends a control word to the MBP indicating the start of a slice.

### 7.4.2.8 *Run-length coding and variable-length coding*

The MBP compresses the quantized DCT coefficients by (zero) Run-Length Coding (RLC) and Variable-Length Coding (VLC). To inform the ASIP about the achieved compression, it sends the number of bits used in the bit stream to the ASIP. The maximum number of bits used for each of the six blocks (see Section 7.4.2.5) must be set by the ASIP. Furthermore, the coded block pattern is sent to the ASIP.

### 7.4.2.9 *Addressing*

The MBP only relies on the format used to store macroblocks in the external DRAM. It works independently from the memory map where to find which macroblock. The ASIP has to keep track of the macroblocks base addresses and has to inform the MBP where to find the data. The MBP only increments the addresses to fetch next data or to write results back.

### 7.4.2.10 *Communication with the ASIP*

The communication with the ASIP is the same for every macroblock. That means that although many settings remain unchanged they have to be repeatedly sent from the ASIP to the MBP. The communication is handled by FIFOs.

## 7.5 Bit stream assembly

### 7.5.1 GENERAL

While MBP only processes the incoming video data and the ASIP generates the corresponding MPEG2 compliant header and stuffing information, these information must be gathered to form a complete output stream.

Parts involved are:

- Packing unit (packer and pre-packer)
- Stuffing unit (Buffer\_out\_address and Buffer\_out\_data)
- Various FIFOs connecting all parts together.

The packing unit does the bit-wise processing of the ASIP and MBP generated streams while the stuffing unit is byte oriented. Handshaking of all blocks is done via FIFOs.

### 7.5.2 PRE-PACKER AND PACKER

The packing unit (consisting of packer and pre-packer) is responsible to compose a fluent bitstream. Each clock cycle the packer gets a certain amount of valid bits (0 to 24) as input data either from the ASIP (e.g. header information) or from the MBP (compressed macroblock coefficients via pre-packer) and generates 64-bit words with valid bits only. These words are stored into the 4 Mbit output buffer located in the external DRAM.

To reduce the memory needs of the compressed macroblock data, a pre-packing to get words of 24 valid bits is performed before storing data for packing.

## Encoder for MPEG2 image recording (EMPIRE)

SAA6750H

### 7.5.3 STUFFING UNIT AND OUTPUT BUFFER

Stuffing is used to extend the output bit-rate e.g. in constant bit-rate applications. Byte stuffing is performed by the buffer-out-data circuit. Once for every MPEG2 start code, the ASIP provides a 24-bit data word containing the number of stuffing bytes to be inserted. To reduce internal memory and bandwidth requirements, the stuffing bytes are inserted at the output of the output buffer, the very end of the internal data path.

The output buffer is needed to decouple the data output rate of the SAA6750H from the internal stream processing. The 4 Mbit output buffer is located in the external DRAM. The ASIP monitors the fullness of the buffer and can perform a buffer regulation by manipulating the stream bit-rate. A lower and an upper watermark are implemented to monitor the fullness of the output buffer via the data output port. If the data level is below the lower watermark, pin LRQN goes LOW, indicating that the buffer is running out of data. If the data level is above the upper watermark, pin URQN goes LOW, indicating a potential overflow and loss of data. Both watermarks may be programmed via I<sup>2</sup>C-bus. See Section 7.6 and Table 23 for detailed information.

## 7.6 Data output port

### 7.6.1 GENERAL

The data output port connects the SAA6750H's data output stream to the outside world. The data output port interface can be adapted to Motorola and Intel-style bus protocols and to different addressing modes. The status of the internal data buffer is reported by dedicated output signals.

The SAA6750H's data output interface will always behave as slave on the bus.

### 7.6.2 DATA OUTPUT FORMAT

The output data is provided in 16-bit words. The most significant bit of the data word represents the earliest bit in the serial MPEG2 elementary stream. Depending on the addressing mode the external host uses for selection of the data output port, the bus transfers plain data (non-multiplex mode) or a multiplex of addresses and data (multiplex mode). See Section 7.6.3 for information about the interface protocol.

### 7.6.3 FUNCTIONAL DESCRIPTION

#### 7.6.3.1 General

The data output port supports Motorola and Intel-style bus protocols.

The addressing can be carried out by the external host in two different modes:

#### 1. Internal address decoding

The data output port provides a programmable internal address decoding. This does support e.g. the use of several slaves on the bus. The data output port's 16-bit address is determined by the setting of bytes BUS ADDRESS (MSB) and BUS ADDRESS (LSB) in the I<sup>2</sup>C-bus control register (see Table 23). During reset mode the contents of BUS ADDRESS will be set to 0000H.

The external host may select the data output port by sending the address value that was programmed in the I<sup>2</sup>C-bus control register. In internal address decoding mode, the output data bus carries multiplexed address and data information.

The CSN pin is not used in this mode and must be set to HIGH.

#### 2. External address decoding

External address decoding mode may be appropriate if e.g. an external address decoding hardware is available or if the SAA6750H is the only slave on the bus. The data output port is selected by setting pin CSN to LOW. In this mode, the internal address decoder is disabled and consequently the setting of bytes BUS ADDRESS is ignored. In external address decoding mode, the output data bus carries plain data information.

The bus protocol mode and address decoding mode are depending on the settings of the I<sup>2</sup>C-bus control register bit BUS and the logic level of the I\_MN pin.

See Tables 12 and 24 and Sections 7.6.3.4 and 7.6.3.5 for detailed information.

Encoder for MPEG2 image recording  
(EMPIRE)

SAA6750H

**Table 12** Data output port mode selection

BIT BUS	PIN I_MN	FUNCTION
0	0	Intel-style protocol mode with external address decoding (non-multiplexed bus); note 1
0	1	Motorola-style protocol mode with external address decoding (non-multiplexed bus); note 1
1	0	Intel-style protocol mode with internal 16-bit address decoding (multiplexed bus); notes 1 and 2
1	1	Motorola-style protocol mode with internal 16-bit address decoding (multiplexed bus); notes 1 and 2

**Notes**

1. Bit BUS is set to LOW during reset mode.
2. The 16-bit data output port address (see Table 23) must be loaded via the I<sup>2</sup>C-bus with the application specific value. The default address is set to 0000H during reset mode.

**7.6.3.2 Interface definition**

The data output interface uses in total 23 pins. Pins AD0 to AD15 carry data and address information. 7 pins are reserved for control purposes. Partly, the functionality of these pins changes with the selected address or protocol mode (see Tables 13 and 14).

**Table 13** List of pins data output port

PIN NAME	PIN TYPE	DESCRIPTION
AD0 to AD15	input/output	internal address decoding: multiplexed address/data bus; external address decoding: non-multiplexed data bus
AS_ALE	input	protocol mode depending functionality; see Table 14
CSN	input	internal address decoding: not used; connect to HIGH; external address decoding: data output port select input
DS_RDN	input	protocol mode depending functionality; see Table 14
DTACK_RDY	output	protocol mode depending functionality; see Table 14
I_MN	input	select protocol mode: Motorola-style protocol mode = LOW; Intel-style protocol mode = HIGH
LRQN	output	LRQN = LOW indicates that the fullness of the output buffer is below the programmable lower watermark value
URQN	output	URQN = LOW indicates that the fullness of the output buffer is 2 times higher than the programmable higher watermark value

**Table 14** Protocol mode depending pins

PIN NAME	MOTOROLA-STYLE PROTOCOL MODE		INTEL-STYLE PROTOCOL MODE	
	AS_ALE	AS	address strobe	ALE
DS_RDN	DS	data strobe	RDN	read not
DTACK_RDY	DTACK	data transfer acknowledge	RDY	data transfer ready

## Encoder for MPEG2 image recording (EMPIRE)

SAA6750H

### 7.6.3.3 Status reporting data output buffer

The SAA6750H's data output port provides information about the status of the internal 4 Mbit output buffer. Two signals that are available via pins LRQN and URQN are related to internal buffer watermarks. The external host may use this information to control the data stream in a way that highest rates are possible without out-of-data or buffer-overflow situations. The watermark levels are programmable via I<sup>2</sup>C-bus (see Table 24).

The lower watermark reporting may be used by the host to prevent out-of-data situations. The fullness of the data output buffer is monitored. If the current value is below the threshold programmed in control word BS\_BUFFER LOWER LEVEL in the I<sup>2</sup>C-bus control register, the signal LRQN goes to LOW. The host may use this information to stop requesting data. Value BS\_BUFFER LOWER LEVEL has a range of 0 to 63. If the value is set to logic 0, LRQN will not be activated. Since the data output buffer stores the output data in 64-bit words, the threshold can be selected in 64-bit steps.

The upper watermark reporting may be used by the host to prevent data overflow of the SAA6750H's output buffer. The fullness of the data output buffer located in the external DRAM is monitored. If the current value is two times or more than two times the value programmed in bytes BS\_BUFFER UPPER LEVEL in the I<sup>2</sup>C-bus control register, the signal URQN goes to LOW. The host may use this information to start requesting data. If it does not, an internal buffer overflow may result in loss of data. Value BS\_BUFFER UPPER LEVEL has a valid range of 1 to 32752. As mentioned, this value will internally be multiplied by 2. Since the data output buffer stores the output data in 64-bit words and the reference value is multiplied by 2, the threshold can be selected in 128-bit steps. The maximum watermark value equals 4 Mbit.

During reset mode, BS\_BUFFER LOWER LEVEL and BS\_BUFFER UPPER LEVEL are set to logic 0. The I<sup>2</sup>C-bus control register values BS\_BUFFER should be initialized with the desired values before starting operation mode. If BS\_BUFFER LOWER LEVEL has a value greater than 0, LRQN will be LOW as long as no valid data is available.

It should be noted that the data output buffer does not contain the stuffing bytes. These are inserted on the fly at the output of the data output buffer. Therefore, if stuffing is active, the amount of data that can be retrieved from the data output port can be higher than indicated by the watermark reporting.

### 7.6.3.4 Intel-style protocol mode

#### 1. Internal address decoding

The host starts a data transfer cycle by applying the data output port address onto the multiplexed address/data lines (see Fig.17). By setting AS\_ALE to LOW the host indicates that the address is valid and by setting DS\_RDN to LOW that it gives up driving the address data and wants to read a data word from the SAA6750H's data output interface. The SAA6750H will drive DTACK\_RDY to LOW, place data onto AD15 to AD0 and indicate by a rising signal DTACK\_RDY that the data on the bus is valid. The duration of the DTACK\_RDY pulse is depending on the internal processing in the data output port and the availability of data. A DS\_RDN = HIGH by the host will force the SAA6750H to stop driving the data bus. The data read sequence may be repeated by setting DS\_RDN to LOW and so forth.

The transfer cycle is ended as soon as the host sets DS\_RDN and after this AS\_ALE back to HIGH. In case of the SAA6750H drives DTACK\_RDY to LOW the host can interrupt the transfer by setting DS\_RDN or AS\_ALE to HIGH however this may result in loss of data. Signal CSN has to be HIGH all the time. See Fig.17 and Chapter "Characteristics" for timing information.

#### 2. External address decoding

The host starts a data transfer cycle by setting the CSN signal to LOW (see Fig.18). By setting DS\_RDN to LOW the host indicates that it wants to read a data word and allows the SAA6750H's data output interface to send data via the bus. The SAA6750H will drive DTACK\_RDY to LOW, place data onto AD15 to AD0 and indicate by a rising signal DTACK\_RDY that the data on the bus is valid. The duration of the DTACK\_RDY pulse depends on the internal processing in the data output port and the availability of data. A DS\_RDN = HIGH by the host will force the SAA6750H to stop driving the data bus. The data read sequence may be repeated by setting DS\_RDN to LOW and so forth.

The transfer cycle is ended as soon as the host sets DS\_RDN and after this CSN back to HIGH. In case of the SAA6750H drives DTACK\_RDY to LOW the host can interrupt the transfer by setting DS\_RDN or CSN to HIGH however this may result in loss of data. Signal AS\_ALE has to be HIGH all the time. See Fig.18 and Chapter "Characteristics" for timing information.

## Encoder for MPEG2 image recording (EMPIRE)

SAA6750H

### 7.6.3.5 Motorola-style protocol mode

#### 1. Internal address decoding

The host starts a data transfer cycle by applying the data output port address onto the multiplexed address/data lines (see Fig.19). By setting AS\_ALE to LOW the host indicates that the address is valid and by setting DS\_RDN to LOW that it gives up driving the address data and allows the SAA6750H's data output interface to send data via the bus. The SAA6750H will drive DTACK\_RDY to LOW, when it has placed valid data onto AD15 to AD0. A DS\_RDN = HIGH by the host will force the SAA6750H to set DTACK\_RDY back to HIGH, to stop driving the data bus and to interrupt the transfer of the current word however this may lead to a loss of data. The data read sequence may be repeated by setting DS\_RDN to LOW and so forth.

The transfer cycle is ended as soon as the host sets DS\_RDN and AS\_ALE back to HIGH. After this, the SAA6750H will also set DTACK\_RDY to HIGH and stops driving data after a delay  $t_{dz}$  (see Chapter "Characteristics"). A new transfer cycle may not be started as long as DTACK\_RDY is LOW or the SAA6750H is driving the data bus. CSN has to be HIGH all the time. See Fig.19 and Chapter "Characteristics" for timing information.

#### 2. External address decoding

The host starts a data transfer cycle by setting the CSN signal to LOW (see Fig.20). By setting DS\_RDN to LOW the host indicates that it wants to read a data word and allows the SAA6750H's data output interface to send data via the bus. The SAA6750H will drive DTACK\_RDY to LOW, when it has placed valid data onto AD15 to AD0. A DS\_RDN = HIGH by the host will force the SAA6750H to set DTACK\_RDY back to HIGH, to stop driving the data bus and to interrupt the transfer of the current word however this may lead to a loss of data. The data read sequence may be repeated by setting DS\_RDN to LOW and so forth.

The transfer cycle is ended as soon as the host sets DS\_RDN and CSN back to HIGH. After this, the SAA6750H will also set DTACK\_RDY to HIGH and stop driving data after a delay  $t_{dz}$  (see Chapter "Characteristics"). A new transfer cycle may not be started as long as DTACK\_RDY is LOW or the SAA6750H is driving the data bus. AS\_ALE has to be HIGH all the time. See Fig.20 and Chapter "Characteristics" for timing information.

### 7.7 Application Specific Instruction-set Processor (ASIP)

#### 7.7.1 GENERAL

The ASIP is a programmable controller specially designed for the architecture and system requirements of the SAA6750H. Generally it has to cover internal control functions. E.g. following tasks are handled:

- Controlling of the MBP
- Macroblock base address generation for the MBP
- Motion vector generation
- Bit stream header generation
- Management of bit stream assembly
- Bit-rate control.

Since the ASIP is software controlled, functioning can be changed by using a different microcode. This gives a high flexibility and allows tailoring of customized sets of functions. The ASIP's microcode has to be downloaded by I<sup>2</sup>C-bus into internal RAMs during initialization of the SAA6750H.

The ASIP is able to communicate with the outside world via an I<sup>2</sup>C-bus interface (see Section 7.9.4) and a high-speed parallel port, the GPIO port.

#### 7.7.2 ASIP SOFTWARE

The ASIP needs a dedicated microcode as well as specific data in form of tables and constants. These have to be loaded into the internal RAMs as described in Sections 7.9.3 and 7.9.4 before operating the SAA6750H. On the fly control of the ASIP is possible by changing the settings in the I<sup>2</sup>C-bus serial in register. The ASIP microcode is closely related to the quantizer matrix data and the I<sup>2</sup>C-bus control register settings. Philips Semiconductors will provide software packages for various applications containing all these data and settings. A description of functions and handling is included in the software specification.

For ASIP hardware as well as software development a special design tool is used. This tool combines the creation of a HIGH-level hardware description of the customized embedded processor and a microcode development environment. This approach allows short design loops for hardware as well as the embedded microcode. On the other hand, software development can only be carried out if also the internal circuitry description is available.

## Encoder for MPEG2 image recording (EMPIRE)

SAA6750H

### 7.7.3 GPIO PORT

#### 7.7.3.1 General

The GPIO port is a bi-directional high speed port connecting the Application Specific Instruction-set Processor (ASIP) to the outside world. This 12 bit wide data interface is connected to the ASIP via FIFOs AO and AI, both having a storage depth of 2 words.

**Note:** The function of this port has to be supported by the ASIP software. See the software specification for detailed information.

#### 7.7.3.2 Interface definition

The GPIO bus interface consists of 12 bi-directional data lines, two control inputs (FAD\_EN and FAD\_RWN) and an output signal (FAD\_RDYN) indicating the internal status of the GPIO port. The external processor connected to the GPIO serves as master. It controls the GPIO by setting the signals FAD\_EN and FAD\_RWN (see Table 15).

The interface protocol requires a handshake between master and SAA6750H using the FAD\_EN and FAD\_RDYN signals (see Tables 15 and 16).

The control signals have to be synchronous to the external clock signal VCLK.

**Table 15** GPIO port operation modes

OPERATION MODE	FAD_EN	FAD_RWN	FUNCTION
Idle mode	0	X	GPIO port idle, pins in input mode
Read mode	1	1	read data from the GPIO port to the external master
Write mode	1	0	write data from the external master to the GPIO port

**Note the following constraints:**

1. FAD\_RWN may not change while FAD\_EN = HIGH.
2. In write mode the data word has to be valid when FAD\_EN goes HIGH.
3. Don't set FAD\_EN to HIGH, if FAD\_RDYN is still LOW. I.e. don't start a second data transmission unless the first is finished. Take special care when switching from read to write mode. The data pins will be in output mode as long as FAD\_RDYN is LOW.

**Table 16** GPIO data ready signal

MODE	FAD_RDYN	FUNCTION
Idle mode	1	idle
Read mode	1	no valid data; GPIO data pins in input mode
	0	valid data available; GPIO data pins in output mode
Write mode	1	data not acknowledged; GPIO data pins in input mode
	0	data acknowledged; GPIO data pins in input mode

#### 7.7.3.3 Functional description

The GPIO port provides a read mode to read data from the FIFO AO to the external host and a write mode to write data from the external host to the FIFO AI. The ASIP has to take care of filling FIFO AO with the desired data and of reading data from FIFO AI. It should be noted that only dedicated software versions support this function.

Three clock cycles after activating the read mode by setting simultaneously FAD\_EN and FAD\_RWN to HIGH a valid data word transferred from FIFO AO will be available at the GPIO output pins (see Fig.21).

The availability of the data word is indicated by FAD\_RDYN = LOW. The GPIO port will now wait for the host's handshake which has to be performed by setting FAD\_EN to LOW. After this is detected by the SAA6750H, FAD\_RDYN will be set to HIGH. The read sequence is now finished. The data port will be in output mode providing the valid data word as long as FAD\_RDYN = LOW. A new READ or WRITE cycle should only be started by the host if FAD\_RDYN is back to HIGH. If the FIFO AO is empty, a read mode request will lead to a deadlock until FIFO AO gets new data from the ASIP. A reset can be carried out by setting FAD\_EN to LOW.

Two clock cycles after activating the write mode by setting simultaneously FAD\_EN to HIGH and FAD\_RWN to LOW the data word provided at the GPIO data inputs will be written into the FIFO AI (see Fig.22). The input data word has to be valid when the write mode is activated and has to be provided until FAD\_RDYN is LOW, indicating the receipt of the data word. The GPIO port will now wait for the host's handshake which has to be performed by setting FAD\_EN to LOW. Two clock cycles after this is detected, FAD\_RDYN will be set to HIGH. The write sequence is now finished. A new WRITE or READ cycle should only be started by the host if FAD\_RDYN is back to HIGH.



# Encoder for MPEG2 image recording (EMPIRE)

## SAA6750H

If the FIFO AI is full, a WRITE operation will lead to a deadlock until the ASIP fetches data from the FIFO AI. A reset can be carried out by setting FAD\_EN to LOW.

### 7.8 Global controller

#### 7.8.1 GENERAL

The global controller generates a global scheduling for SAA6750H's loosely coupled processes. It is controlled by the bits E\_ST, E\_SP, SS and STD which are located in the I<sup>2</sup>C-bus control register (see Table 24). The global controller is automatically synchronized with the front-end block.

#### 7.8.2 FUNCTIONAL DESCRIPTION

The global controller is a state machine, which performs a state transition every 650 clock cycles. This value defines the macroblock processing time. Depending on the state, it issues start commands for the DRAM interface, the MBP and the ASIP. Figure 11 shows the scheduling scheme generated by the global controller. The start pulse to the MBP has a programmable delay with respect to the ASIP and DRAM interface start pulses. It can be sent up to 15 clock cycles earlier or up to 240 clock cycles later. This value is programmable via the I<sup>2</sup>C-bus control word SHIFT START (see Table 24). It should be noted that the correct value is depending on the ASIP software. See the software specification for detailed information.

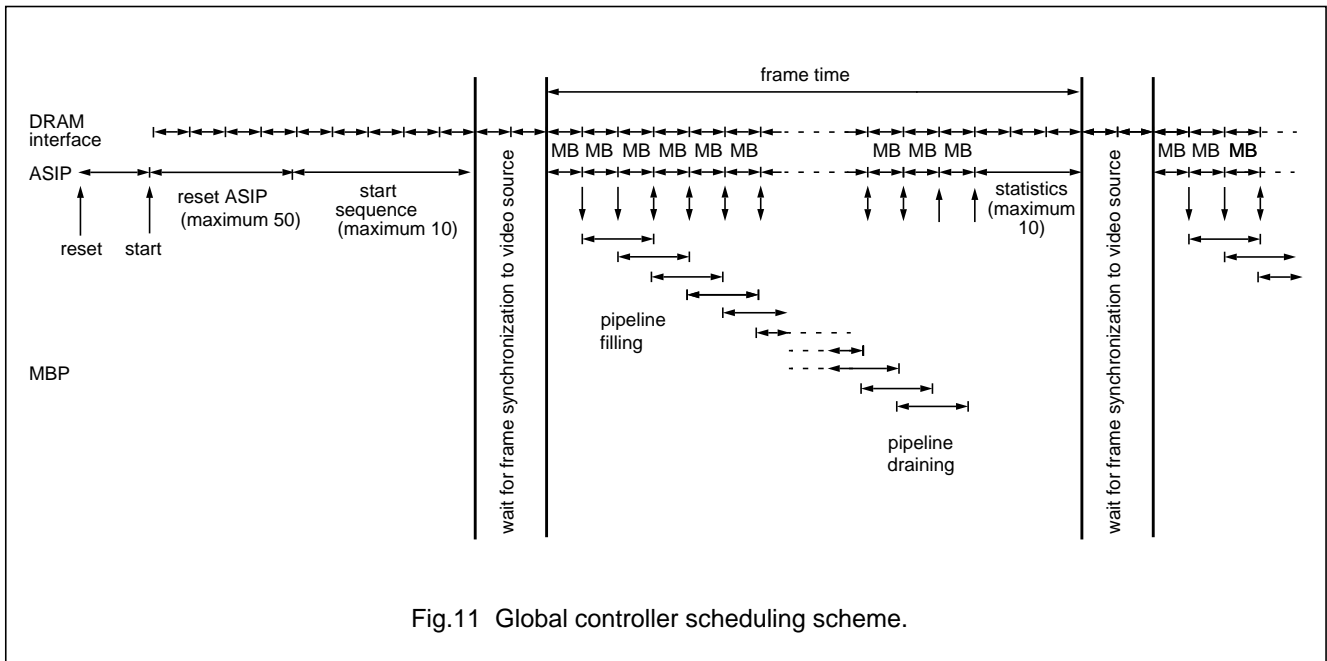

Fig.11 Global controller scheduling scheme.

### 7.9 I<sup>2</sup>C-bus interface and controller

#### 7.9.1 GENERAL

The I<sup>2</sup>C-bus interface within the SAA6750H is a slave transceiver. It is used to download the ASIP's microcode, constants and tables as well as the quantization matrix table to the MBP. In addition, all control settings are carried out via I<sup>2</sup>C-bus. The read mode may be used to read back data from registers connected internally to the ASIP. In total 8 different subaddresses are used to store or read data.

The I<sup>2</sup>C-bus interface is compliant to the I<sup>2</sup>C-bus standard at 100 and 400 kHz clock frequency and suitable for bus line voltage levels from 3.3 to 5 V.

The I<sup>2</sup>C-bus slave address (SAD) is 40H respectively 42H depending on the state of pin MAD. This allows the use of two devices SAA6750H in one application.

See the general I<sup>2</sup>C-bus specification for detail information on the bus protocol.

# Encoder for MPEG2 image recording (EMPIRE)

## SAA6750H

### 7.9.2 SPECIAL CONSIDERATIONS

Eight subaddresses are used to read or write data from or to SAA6750H's internal SRAM memories and registers. An explanation of purpose, function and data transfer will be given in the following chapters. It should be noted that all subaddresses can only be used as data sink or as data source. E.g. it is not possible to write data into a register and read it back later on.

Due to the internal memory architecture data may only be transmitted to the subaddresses 00H to 03H when the SAA6750H is in init mode. After the control bit E\_ST is set to HIGH, sending data via I<sup>2</sup>C-bus to the SRAMs 00H to 03H is forbidden.

The I<sup>2</sup>C-bus interface will not respond to the general call address 00H and it will not use clock stretch to slow down a data transmission.

The acknowledgement of a data byte by the I<sup>2</sup>C-bus interface only indicates that the transmission was received and that the correct slave address was used. It does not necessarily say that the data reached its destination. E.g. also if a subaddress outside the valid range from 0 to 7 was sent to the SAA6750H or a transmission to subaddress 01H took place while bit E\_ST was HIGH, the I<sup>2</sup>C-bus interface will return an acknowledge.

A special sequence of commands is used to read data from the subaddress 04H. See Section 7.9.3.4 for detailed information.

### 7.9.3 I<sup>2</sup>C-BUS DATA TRANSFER MODES

#### 7.9.3.1 General

Data transfer follows the I<sup>2</sup>C-bus specification for fast (400 kHz) or normal (100 kHz) mode. The SAA6750H slave address in write mode is:

- 40H if pin MAD is LOW
- 42H if pin MAD is HIGH.

For read operations the following slave addresses have to be used:

- 41H if pin MAD is LOW
- 43H if pin MAD is HIGH.

The I<sup>2</sup>C-bus will transfer data always as a whole byte consisting of 8 bits. If the address or data word consists of several bytes, the most significant byte (MSB) has to be sent first and the least significant byte (LSB) last. This rule does also apply for read operations. In this case the MSB will be received first.

If the memory's address or data word does not have a width of a multiple of 8 bits, dummy bits have to be added on the left side (most significant bit side) of the MSB. E.g. the ASIP microcode has 177 bits wide data words. 177 divided by 8 gives 22 and a remainder of 1. Therefore the I<sup>2</sup>C-bus master has to send 23 data bytes of which the higher 7 bits of the MSB are dummy bits. Also the same rule applies for read operations.

Depending on the type of storage the data transfer to or from the memories and registers has to be carried out in different modes which will be described in the following chapters.

**Table 17** Abbreviations used in data transfer diagrams

ABBREVIATIONS	FUNCTION
S	I <sup>2</sup> C-bus START condition, generated by master
RS	I <sup>2</sup> C-bus REPEATED START condition, generated by master
SAD	Higher 7 bits of slave address byte. 7-bit slave address: 0100000 (MAD pin = LOW), 40H/41H; 7-bit slave address: 0100001 (MAD pin = HIGH); 42H/43H
W	write mode: LSB of slave address byte = 0
R	read mode: LSB of slave address byte = 1
MA	master acknowledge (acknowledge generated by master)
MN	master acknowledge not (no acknowledge by master)
SA	slave acknowledge (acknowledge generated by SAA6750H)
SD	8-bit subaddress
ADR	address byte
DATA	data byte to be written/read
P	I <sup>2</sup> C-bus STOP condition, generated by master

## Encoder for MPEG2 image recording (EMPIRE)

SAA6750H

### 7.9.3.2 Random access write mode

This mode provides random access to specific memory addresses.

The data has to be written according to following scheme:

**Table 18** Data transfer using random access write mode

S	SAD	W	SA	SD	SA	ADR1 (MSB)	SA	ADR2 (LSB)	SA	DATA <sub>1</sub> (MSB)	SA	...	DATA <sub>n-1</sub>	SA	DATA <sub>n</sub> (LSB)	SA	P
---	-----	---	----	----	----	---------------	----	---------------	----	----------------------------	----	-----	---------------------	----	----------------------------	----	---

In this example the address word consists of 2 bytes and the data word out of n bytes. This sequence has to be repeated for every data word that has to be sent to the memory.

### 7.9.3.3 Write mode

The write mode is used if a number of data bytes has to be written to a subaddress if there is no specific memory address. I.e. this mode is used to write data to registers. The data has to be sent according to following scheme:

**Table 19** Data transfer using write mode

S	SAD	W	SA	SD	SA	DATA <sub>1</sub> (MSB)	SA	DATA <sub>2</sub> (MSB - 1)	SA	DATA <sub>3</sub> (MSB - 2)	SA	...	DATA <sub>n-1</sub>	SA	DATA <sub>n</sub> (LSB)	SA	P
---	-----	---	----	----	----	----------------------------	----	--------------------------------	----	--------------------------------	----	-----	---------------------	----	----------------------------	----	---

In this example the data word consists of n bytes.

### 7.9.3.4 Read mode

This mode is used to read data bytes from memories or registers. It is not possible to access a specific memory address. The first byte to be received will be the MSB. If a certain information is needed, the read transfer has to be carried out until the specific byte is available. The data transfer has to be closed by the I<sup>2</sup>C-bus master by sending an MN (not acknowledge) after the last data byte. This tells the SAA6750H to stop sending further data.

The transfer has to follow this scheme:

**Table 20** Data transfer using read mode

S	SAD	W	SA	SD	SA	RS	SAD	R	DATA <sub>1</sub> (MSB)	MA	DATA <sub>2</sub> (MSB - 1)	MA	...	DATA <sub>n-1</sub>	MA	DATA <sub>n</sub> (LSB)	MN	P
---	-----	---	----	----	----	----	-----	---	----------------------------	----	--------------------------------	----	-----	---------------------	----	----------------------------	----	---

In this example the read operation gets n data bytes out of the SAA6750H.

## Encoder for MPEG2 image recording (EMPIRE)

SAA6750H

### 7.9.4 I<sup>2</sup>C-BUS MEMORIES AND REGISTERS

Eight different SRAM memories and registers may be written or read via I<sup>2</sup>C-bus. Each has a specific subaddress. This chapter will explain the purpose of these storages and how they have to be used.

#### 7.9.4.1 Allocation of subaddresses

Following table shows which memories or registers are allocated to the subaddresses 0 to 7:

**Table 21** Subaddresses and related memories

SUBADDRESS (HEX)	STORAGE NAME	DESIGN BLOCK	DEPTH (WORDS)	WIDTH (BITS)	DESCRIPTION
00	quantization matrix SRAM	MBP	128	8	SRAM memory containing a constant table for the macroblock processor quantization function.
01	microcode SRAM	ASIP	1024	177	SRAM memory containing the ASIP's microcode.
02	microcode ROM table	ASIP	512	24	SRAM memory containing the ASIP's microcode ROM table.
03	microcode constants	ASIP	256	24	SRAM memory containing the ASIP's microcode constants.
04	serial output register	ASIP	7	24	Register bank that can be written by the ASIP. Contents depending on ASIP software.
05	serial input register	ASIP	14	24	Register bank that can be read by the ASIP. Used to control the ASIP externally. The function of register settings is depending on the ASIP software.
06	control register	I <sup>2</sup> C-bus	1	160	Register containing the SAA6750H hardware control bits.
07	internal use	none	–	–	–

## Encoder for MPEG2 image recording (EMPIRE)

SAA6750H

### 7.9.4.2 I<sup>2</sup>C-bus data transfer to subaddresses

The following tables describe the data transfer to or from the subaddresses 0 to 7. See Sections 7.9.3.2, 7.9.3.3 and 7.9.3.4 for information of the data transfer modes.

**Table 22** Data transfer to subaddresses

SUBADDRESS (HEX)	STORAGE NAME	DATA TRANSFER MODE	ADDRESS BYTES PER TRANSMISSION	DATA BYTES PER TRANSMISSION	I <sup>2</sup> C-BUS BYTE TRANSFERS PER TRANSMISSION
00	quantization matrix SRAM	random access write mode	1	1	4 = 2 + 1 + 1
01	microcode SRAM	random access write mode	2	23	27 = 2 + 2 + 23
02	microcode ROM table	random access write mode	2	3	7 = 2 + 2 + 3
03	microcode constant	random access write mode	1	3	6 = 2 + 1 + 3
04	serial output register	read mode	0	21	24 = 2 + 1 + 21
05	serial input register	random access write mode	1	24	6 = 2 + 1 + 3
06	control bits register	write mode	0	20	22 = 2 + 20
07	internal use	none	–	–	–

### 7.9.4.3 Quantization matrix SRAM

SUBADDRESS (HEX)	STORAGE NAME	DESIGN BLOCK	DEPTH (WORDS)	WIDTH (BITS)	DATA TRANSFER MODE
00	quantization matrix SRAM	MBP	128	8	random access write mode

SRAM memory containing a constant table for the macroblock processor quantization function.

The data to be loaded into this memory will be part of the application software and described in the software specification.

**Note:** Data may only be sent to this subaddress if the SAA6750H is in the init mode (see Table 25).

### 7.9.4.4 Microcode SRAM

SUBADDRESS (HEX)	STORAGE NAME	DESIGN BLOCK	DEPTH (WORDS)	WIDTH (BITS)	DATA TRANSFER MODE
01	microcode SRAM	ASIP	1024	177	random access write mode

SRAM memory containing the ASIP's microcode.

The microcode to be loaded into this memory will be part of the application software and described in the software specification.

**Note:** Data may only be sent to this subaddress if the SAA6750H is in the init mode (see Table 25).

## Encoder for MPEG2 image recording (EMPIRE)

SAA6750H

### 7.9.4.5 Microcode ROM table SRAM

SUBADDRESS (HEX)	STORAGE NAME	DESIGN BLOCK	DEPTH (WORDS)	WIDTH (BITS)	DATA TRANSFER MODE
02	microcode ROM table SRAM	ASIP	512	24	random access write mode

SRAM memory containing special tables that are needed by the ASIP software. The quantization matrix data loaded into subaddress 0 is also part of this set of data.

The data to be loaded into this memory will be included in the application software and described in the software specification.

**Note:** Data may only be sent to this subaddress if the SAA6750H is in the init mode (see Table 25).

### 7.9.4.6 Microcode constant SRAM

SUBADDRESS (HEX)	STORAGE NAME	DESIGN BLOCK	DEPTH (WORDS)	WIDT (BITS)	DATA TRANSFER MODE
03	microcode constant SRAM	ASIP	256	24	random access write mode

SRAM memory containing constants that are needed by the ASIP software.

The data to be loaded into this memory will be included in the application software and described in the software specification.

**Note:** Data may only be sent to this subaddress if the SAA6750H is in the init mode (see Table 25).

### 7.9.4.7 Serial output register

SUBADDRESS (HEX)	STORAGE NAME	DESIGN BLOCK	DEPTH (WORDS)	WIDTH (BITS)	DATA TRANSFER MODE
04	serial output register	ASIP	7	24	read mode

Register bank that can be written by the ASIP and read by I<sup>2</sup>C-bus.

The ASIP is able to access a specific register by writing the address and the related data word. On the contrary it is not possible to access a specific register by I<sup>2</sup>C-bus. Starting an I<sup>2</sup>C-bus read operation will return the data of register 0 first, starting with the most significant byte. After the LSB of register 0 was received, the register address will be incremented automatically and the MSB of register 1 will be received next. Consequently, 21 data words have to be read if the data of register 6 is needed.

The register data depends on the ASIP's software and the state of the SAA6750H. A description will be part of the software specification.

## Encoder for MPEG2 image recording (EMPIRE)

SAA6750H

### 7.9.4.8 Serial input register

SUBADDRESS (HEX)	STORAGE NAME	DESIGN BLOCK	DEPTH (WORDS)	WIDTH (BITS)	DATA TRANSFER MODE
05	serial input register	ASIP	14	24	random access write mode

Register bank that can be read by the ASIP. Used to control the ASIP externally. The function of register settings is depending on the ASIP software. A description will be part of the software specification.

The valid address range reaches from 01H to 0EH. Any data sent by I<sup>2</sup>C-bus to address 00H will always be overwritten by an internal signal.

### 7.9.4.9 Control register

SUBADDRESS (HEX)	STORAGE NAME	DESIGN BLOCK	DEPTH (WORDS)	WIDTH (BITS)	DATA TRANSFER MODE
06	control register	I <sup>2</sup> C	1	160	write mode

Register bank used to control internal signals. The allocation of control bits in the register is shown in Table 23. The function of the specific bits is described in Table 24.

During external reset, all register bits will be set to LOW.

During initialization all 20 bytes starting with the MSB and ending with the LSB (control) have to be sent by I<sup>2</sup>C-bus in one go.

Encoder for MPEG2 image recording  
(EMPIRE)

SAA6750H

**Table 23** Description of the I<sup>2</sup>C-bus control register; note 1

REGISTER BYTE	BIT ADDRESS (HEX)	MSB								LSB
		D7	D6	D5	D4	D3	D2	D1	D0	
Control	00 to 07	STD	SS	INTRA	BUS	E_ST	E_SP	SMOD	BYP	
FIFO PMI(S) time slot setting	08 to 0F	PMI7	PMI6	PMI5	PMI4	PMI3	PMI2	PMI1	PMI0	
FIFO WR_AD(MC) time slot setting	10 to 17	WR7	WR6	WR5	WR4	WR3	WR2	WR1	WR0	
FIFO RD_ADR(MA) time slot setting	18 to 1F	RD7	RD6	RD5	RD4	RD3	RD2	RD1	RD0	
FIFO BUF_ADR(H) time slot setting	20 to 27	BUF7	BUF6	BUF5	BUF4	BUF3	BUF2	BUF1	BUF0	
FIFO REFR(G) time slot setting	28 to 2F	RFR7	RFR6	RFR5	RFR4	RFR3	RFR2	RFR1	RFR0	
FIFO MC(E) time slot setting	30 to 37	MC7	MC6	MC5	MC4	MC3	MC2	MC1	MC0	
FIFO ML(B) time slot setting	38 to 3F	ML7	ML6	ML5	ML4	ML3	ML2	ML1	ML0	
FIDP & vertical shift bottom field	40 to 47	FIDP	VSB6	VSB5	VSB4	VSB3	VSB2	VSB1	VSB0	
VREFP & vertical shift top field	48 to 4F	VREFP	VST6	VST5	VST4	VST3	VST2	VST1	VST0	
HREFP & horizontal shift	50 to 57	HREFP	HOR6	HOR5	HOR4	HOR3	HOR2	HOR1	HOR0	
Filter coefficient a3	58 to 5F	FA37	FA36	FA35	FA34	FA33	FA32	FA31	FA30	
Filter coefficient a2	60 to 67	FA27	FA26	FA25	FA24	FA23	FA22	FA21	FA20	
Filter coefficient a1	68 to 6F	FA17	FA16	FA15	FA14	FA13	FA12	FA11	FA10	
Shift start	70 to 77	SH7	SH6	SH5	SH4	SH3	SH2	SH1	SH0	
BS_BUFFER lower level	78 to 7F	X	X	BL5	BL4	BL3	BL2	BL1	BL0	
BS_BUFFER upper level (LSB)	80 to 87	BU7	BU6	BU5	BU4	BU3	BU2	BU1	BU0	
BS_BUFFER upper level (MSB)	88 to 8F	X	BU14	BU13	BU12	BU11	BU10	BU9	BU8	
Bus address (LSB)	90 to 97	DADR7	DADR6	DADR5	DADR4	DADR3	DADR2	DADR1	DADR0	
Bus address (MSB)	98 to 9F	DADR15	DADR14	DADR13	DADR12	DADR11	DADR10	DADR9	DADR8	

**Note**

1. X = don't care; should be set to LOW during initialization.



Encoder for MPEG2 image recording  
(EMPIRE)

SAA6750H

**Table 24** Description of I<sup>2</sup>C-bus control bits and words

BIT NAME	CONTROL WORD NAME	BIT ADDRESS (HEX)	DATA BYTE	DESCRIPTION
BYP		00	19	internal use; it must be set to LOW during initialization
SMOD <sup>(1)</sup>		01		external/internal sync signal selection; LOW: sync is derived from the SAV and EAV information decoded from the data stream at port YUV; HIGH: sync is derived from the external sync signals at pins FID, HSYNC and VSYNC
E_SP		02		engine stop; see Table 25
E_ST		03		engine start; see Table 25
BUS		04		data output port address mode selection; LOW: external address decoding (CSN pin); HIGH: internal address decoding (AD pin)
INTRA		05		maximum output bit-rate selection; use default setting given in the software specification
SS <sup>(1)</sup>		06		non SIF mode/SIF mode selection; LOW: subsampling off; HIGH: subsampling on (SIF mode conversion active)
STD <sup>(1)</sup>		07		NTSC/PAL selection; LOW: NTSC mode input signal expected; HIGH: PAL mode input signal expected
PMI0 to PMI7		08 to 0F	18	use default setting given in the software specification
WR0 to WR7		10 to 17	17	use default setting given in the software specification
RD0 to RD7		18 to 1F	16	use default setting given in the software specification
BUF0 to BUF7		20 to 27	15	use default setting given in the software specification
RFR0 to RFR7		28 to 2F	14	use default setting given in the software specification
MC0 to MC7		30 to 37	13	use default setting given in the software specification
ML0 to ML7		38 to 3F	12	use default setting given in the software specification
VSB0 to VSB6	vertical shift bottom field	40 to 46	11	value determines number of H-syncs occurring after V-sync before the bottom field line based processing starts
FIDP <sup>(1)</sup>		47		FID signal polarity selection; LOW: FID signal not inverted (FID = LOW indicates odd field); HIGH: FID signal inverted (FID = HIGH indicates odd field); this setting takes affect for external as well as for SAV and EAV sync

Encoder for MPEG2 image recording  
(EMPIRE)

SAA6750H

BIT NAME	CONTROL WORD NAME	BIT ADDRESS (HEX)	DATA BYTE	DESCRIPTION
VST0 to VST6 <sup>(1)</sup>	vertical shift top field	48 to 4E	10	value determines number of H-syncs occurring after V-sync before the top field line based processing starts
VREFP <sup>(1)</sup>		4F		VSYNC signal polarity selection; LOW: VSYNC signal not inverted, VREF signal expected at pin VSYNC; HIGH: VSYNC signal inverted, vertical blanking qualifier expected at VSYNC pin; this setting does not affect the sync derived from SAV and EAV codes
HOR0 to HOR6 <sup>(1)</sup>	horizontal shift	55 to 56	9	setting determines the number of clock cycles occurring after the H-sync before the line based processing starts; value should have a multiple of 4 because a minimum data sequence (C <sub>B</sub> , Y, C <sub>R</sub> , Y) needs 4 clock cycles
HREFP <sup>(1)</sup>		57		HSYNC signal polarity selection; LOW: HSYNC signal not inverted, HREF signal expected at pin HSYNC; HIGH: HSYNC signal inverted, horizontal blanking qualifier expected at pin HSYNC; this setting does not affect the sync derived from SAV and EAV codes
FA30 to FA37	Filter coefficient a3	58 to 5F	8	filter coefficient a3 for the horizontal filtering of video input signal
FA20 to FA27	Filter coefficient a2	60 to 67	7	filter coefficient a2 for the horizontal filtering of video input signal
FA10 to FA17	Filter coefficient a1	68 to 6F	6	filter coefficient a1 for the horizontal filtering of video input signal
SH0 to SH7	Shift start (time slot)	70 to 77	5	use default setting given in the software specification
BL0 to BL5	BS_BUFFER lower level	78 to 7D	4	lower watermark value for data output buffer monitoring
		7E to 7F		not used; it must be set to LOW during initialization
BU0 to BU7	BS_BUFFER upper level (LSB)	80 to 87	3	upper watermark value for data output buffer monitoring (LSB); the valid range for BS_BUFFER upper level is 1 to 32752; the value will internally be multiplied by 2
BU8 to BU14	BS_BUFFER upper level (MSB)	88 to 8E	2	upper watermark value for data output buffer monitoring (MSB); the valid range for BS_BUFFER upper level is 1 to 32752; the value will internally be multiplied by 2
		8F		not used; it must be set to LOW during initialization
DADR0 to DADR7	Bus address (LSB)	90 to 97	1	address value for internal address decoding mode of data output port (LSB)
DADR8 to DADR15	Bus address (MSB)	98 to 9F	0	address value for internal address decoding mode of data output port (MSB)

**Note**

- Changes of this setting are only allowed in init mode or soft reset mode. See Section 7.2.3 for information of the SAA6750H operation modes.

## Encoder for MPEG2 image recording (EMPIRE)

SAA6750H

**Table 25** Description of engine bits

E_ST	E_SP	SELECTED OPERATION MODE
0	0	init mode
0	1	soft reset mode
1	0	operation mode
1	1	internal use only

The engine control bits are used to set the SAA6750H in a specific operation mode. After reset mode the init mode will be activated automatically. For information about SAA6750H's operation modes refer to Table 1.

### 7.9.5 I<sup>2</sup>C-BUS INITIALIZATION

After power on and the related RESETN pulse the SAA6750H has to be initialized via the I<sup>2</sup>C-bus. The internal RAMs must be loaded and the control bits must be set.

The internal memories reachable via subaddresses 0, 1, 2 and 3 should be loaded first. Use the data files that belong to a specific ASIP software version. The control register should be written at last. Activate bit E\_ST only if all other settings have the desired state.

There has to be a 0.5 ms delay between the end of the external reset RESETN and the start of the I<sup>2</sup>C initialization.

The registers and memories of the SAA6750H should be initialized in following order:

1. Subaddress 00H: MBP quantization matrix
2. Subaddress 01H: ASIP microcode
3. Subaddress 02H: ASIP microcode ROM table
4. Subaddress 03H: ASIP microcode constant
5. Subaddress 05H: ASIP serial input
6. Subaddress 06H: Control register (see Table 26).

The following example shows a control register setting for PAL input signal, SAV/EAV sync and external output port address decoding for inter and intra mode. It should be noted that the settings for the INTRA bit and the FIFO time slot values are depending on a specific ASIP software version. Use in any case those settings given in the ASIP software specification.

Encoder for MPEG2 image recording  
(EMPIRE)

SAA6750H

**Table 26** Example for control register settings force mode

REGISTER BYTE	I <sup>2</sup> C DATA BYTE	INTER/INTRA MODE		INTRA FORCE MODE	
		BINARY	HEX	BINARY	HEX
Control	19	1000 1000	88	1010 1000	A8
PMI	18	0010 0011	23	0010 0011	23
WR	17	1000 0100	84	1000 0100	84
RD	16	0110 1011	6B	1000 0001	81
BUF	15	0000 0111	07	0000 0111	07
RFR	14	0000 0001	01	0000 0001	01
MC	13	1010 0001	A1	1010 0001	A1
ML	12	1001 0111	97	1001 0111	97
FIDP & vertical shift bottom	11	0000 0000	00	0000 0000	00
VREFP & vertical shift top	10	0000 0000	00	0000 0000	00
HREFP & horizontal shift	9	0000 0000	00	0000 0000	00
Filter coefficient a3	8	0000 0000	00	0000 0000	00
Filter coefficient a2	7	0000 0000	00	0000 0000	00
Filter coefficient a1	6	0000 0000	00	0000 0000	00
Shift start	5	0000 1000	08	0000 0100	04
BS_BUFFER lower level	4	0000 0000	00	0000 0000	00
BS_BUFFER upper level (LSB)	3	1111 1111	FF	1111 1111	FF
BS_BUFFER upper level (MSB)	2	0100 1111	4F	0100 1111	4F
Bus address (LSB)	1	1111 1111	FF	1111 1111	FF
Bus address (MSB)	0	1111 1111	FF	1111 1111	FF

**7.10 DRAM interface**

## 7.10.1 GENERAL

The DRAM interface of the SAA6750H schedules and handles all accesses of internal read and write clients to the external 4 × 4 Mbit DRAM memory. It also takes care of the DRAM refresh after Power-on reset and performs the initialization of the external DRAM.

Four fast page mode DRAM devices ( $t_{\text{RAC}} = 60 \text{ ns}$ ) with 16-bit data and 9-bit row and column address have to be applied in parallel. Therefore the accessible DRAM format is 262 144 × 64 bits.

## 7.10.2 APPLICATION HINTS

It should be noted that the DRAM interface is timing sensitive. Make sure that wires between the SAA6750H and the external DRAM memories are as short as possible. In addition the CASN, RASN, address and data lines should have approximately the same parasitic load.

## 7.10.3 FUNCTIONAL DESCRIPTION

## 7.10.3.1 Interface definition

The connection between the DRAM interface and the memory consists of 77 signals. ADR0 to ADR8 are used to transfer the row or the column address. The signals CASN and RASN indicate, that a column/row address is present on ADR0 to ADR8. WEN enables a write access and OEN selects/deselects the associated memory chip. The signals CASN, RASN, WEN and OEN are active LOW.

## 7.10.3.2 DRAM initialization

After the external reset signal RESETN becomes inactive, the DRAM interface immediately starts generating a DRAM initialisation sequence. First, the Row Address Strobe (RASN) and Column Address Strobe (CASN) are kept stable in HIGH state for a minimum of 200  $\mu\text{s}$ . After this the DRAM interface generates a sequence of initialization pulses. This sequence consists of 9 CASN cycles before RASN refresh (CBR) events (see Fig.16).

## Encoder for MPEG2 image recording (EMPIRE)

SAA6750H

### 7.10.3.3 DRAM refresh

The DRAM interface takes care of the periodically refresh of the external DRAM. Refresh is carried out by addressing the specific DRAM page. It should be noted that refresh only works if the SAA6750H is in operation mode (see Table 1).

### 7.10.3.4 Memory sharing

The SAA6750H can be part of a system in which it shares the memory with other devices. To this end the DRAM interface output ports of the SAA6750H can be put to 3-state respectively input state by an appropriate setting of the I<sup>2</sup>C-bus control register (see Table 1). Another IC can't use the memory concurrently with the SAA6750H.

### 7.10.3.5 Scheduling

The DRAM interface allows access to the external DRAM once every two clock cycles. Therefore the nominal 'Fast Page Mode Cycle Time' is  $t_{PC} = 74$  ns for a 27 MHz clock. If the DRAM address changes from one page to another page, which means a change in the most significant 9 bits of the address, a page transition occurs. A page transition also happens, if the data direction changes from read to write or vice versa (a change of the WEN signal). A detailed description of the timing can be found in Figs 14 and 15 and Chapter "Characteristics".

All internal clients of the DRAM interface are served using a round robin scheme where the access time of each client can be programmed via I<sup>2</sup>C-bus within some limits. These settings are depending on the embedded microcode and will be provided in the software package. Within one macroblock-period, which is defined as 650 clock cycles of the 27 MHz system clock, all clients have to be served at least with two accesses but the sum of all client accesses is not allowed to exceed the time of one macroblock-period.

## 7.11 FIFO memories

The FIFOs are data buffers, which connect the internal processes. This kind of coupling is necessary because due to the multi-processor architecture e.g. one process may give bursts of data, while the next process consumes the data at constant rate. The state of the FIFOs therefore also has an impact on the process behaviour. As long as the FIFO buffers are not full or empty, the depending processes work at their normal speed. If a data read or write request from or to a FIFO can't be served, the depending process is interrupted.

## 7.12 Clock distribution

The SAA6750H needs a video clock signal VCLK as specified in Chapter "Quick reference data". The external clock signal has to be synchronous to the video input data stream. In the standard application e.g. the clock signal is provided by a SAA7111A colour decoder.

The internal clock generation unit creates all internal processing clocks.

## 7.13 Input/output levels

All input and I/O pad cells are 5 V tolerant. The output and I/O pad cells provide 3.3 V output levels. See Chapters "Quick reference data" and "Limiting values" for detailed information.

## 7.14 Boundary scan test

### 7.14.1 GENERAL

The SAA6750H has built-in logic and 5 dedicated pins to support boundary scan testing, which allows board testing without special hardware (nails). The SAA6750H follows the "IEEE Std. 1149.1 - Standard Test Access Port and Boundary Scan Architecture" set by the Joint Test Action Group (JTAG) chaired by Philips.

The 5 special pins are Test Mode Select (TMS), Test Clock (TCK), Test Reset (TRST), Test Data Input (TDI) and Test Data Output (TDO).

The Boundary Scan Test (BST) functions BYPASS, EXTEST, SAMPLE, CLAMP and IDCODE are all supported (see Table 27). Details about the JTAG BST-TEST can be found in the specification "IEEE Std. 1149.1". A file containing the detailed Boundary Scan Description Language (BSDL) description of the SAA6750H is available on request.

# Encoder for MPEG2 image recording (EMPIRE)

SAA6750H

**Table 27** Boundary Scan Test (BST) instructions supported by the SAA6750H

INSTRUCTION	DESCRIPTION
BYPASS	This mandatory instruction provides a minimum length serial path (1 bit) between TDI and TDO, when no test operation of the component is required.
EXTEST	This mandatory instruction allows testing of off-chip circuitry and board level interconnections.
SAMPLE	This mandatory instruction can be used to take a sample of the inputs during normal operation of the component. It can also be used to preload data values into the latched outputs of the boundary scan register.
CLAMP	This optional instruction is useful for testing, when not all IC's have BST. This instruction addresses the bypass register, while the boundary scan register is in external test mode.
IDCODE	This optional instruction will provide information on the components manufacturer, part number and version number.

### 7.14.2 INITIALIZATION OF BOUNDARY SCAN CIRCUIT

The Test Access Port (TAP) controller of an IC should be in the reset state (TEST\_LOGIC\_RESET), when the IC is in functional mode. This reset state also forces the instruction register into a functional instruction such as IDCODE or BYPASS.

To solve the power-up reset, the standard specifies that the TAP controller will be forced asynchronously to the TEST\_LOGIC\_RESET state by setting pin TRST to LOW.

### 7.14.3 DEVICE IDENTIFICATION CODES

A device identification register is specified in "IEEE Std. 1149.1-1990 -IEEE Standard Test Access Port and Boundary Scan Architecture". It is a 32-bit register which contains fields for the specification of the IC manufacturer, the IC part number and the IC version number. Its biggest advantage is the possibility to check for the correct ICs

mounted after production and determination of the version number of IC's during field service.

When the IDCODE instruction is loaded into the BST instruction register, the identification register will be connected between TDI and TDO of the IC.

The identification register will load a component specific code during the CAPTURE\_DATA\_REGISTER state of the TAP controller and this code can subsequently be shifted out. At board level this code can be used to verify component manufacturer, type and version number. The device identification register contains 32 bits, numbered 31 to 0, where bit 31 is the most significant bit (nearest to TDI) and bit 0 is the least significant bit (nearest to TDO); see Fig.12.

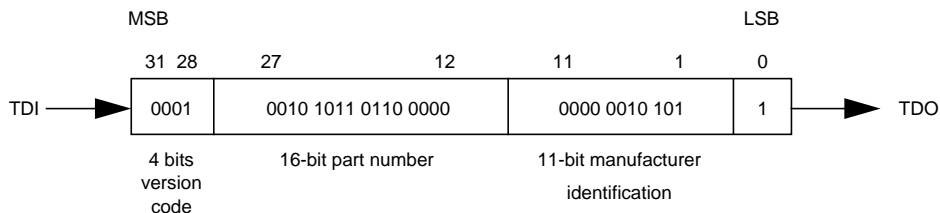

Fig.12 32 bits of identification code.

# Encoder for MPEG2 image recording (EMPIRE)

SAA6750H

## 8 LIMITING VALUES

In accordance with the Absolute Maximum Rating System (IEC 134).

SYMBOL	PARAMETER	CONDITIONS	MIN.	MAX.	UNIT
$V_{DD}$	digital supply voltage		-0.5	+4.0	V
$V_I$	digital input voltage	note 1	-0.5	+5.5	V
$V_O$	digital output voltage		-0.5	$V_{DD} + 0.5$	V
$I_{lu(prot)}$	latch-up protection current		-	100	mA
$P_{tot}$	total power dissipation		-	2.0	W
$T_{stg}$	storage temperature		-25	+150	°C
$T_{amb}$	operating ambient temperature		0	70	°C
$V_{es}$	electrostatic handling	note 2	-2000	+2000	V
		note 3	-150	+150	V

### Notes

1. All input pads as well as I/O pads in input and output pads in 3-state mode are 5 V tolerant.
2. Human body model class B: C = 100 pF; R = 1.5 k $\Omega$ .
3. Machine model class B: C = 200 pF; L = 0.75  $\mu$ H; R = 0  $\Omega$ .

## 9 THERMAL CHARACTERISTICS

SYMBOL	PARAMETER	CONDITIONS	VALUE	UNIT
$R_{th(j-a)}$	thermal resistance from junction to ambient	in free air; soldered to a PCB with supply and ground plane	28	K/W

# Encoder for MPEG2 image recording (EMPIRE)

SAA6750H

## 10 CHARACTERISTICS

Power supply is  $V_{DDCO} = 3.3$  V for the IC core and  $V_{DD} = 3.3$  V for the I/O pads; both supply voltages  $V_{DD}$  and  $V_{DDCO}$  are connected externally together and also both grounds  $V_{SS}$  and  $V_{SSCO}$ ;  $T_{amb} = 25$  °C; unless otherwise specified.

SYMBOL	PARAMETER	CONDITIONS	MIN.	TYP.	MAX.	UNIT
<b>Supply: <math>V_{DD}</math> and <math>V_{DDCO}</math></b>						
$V_{DD}$	digital supply voltage (I/O cells)		3.0	3.3	3.6	V
$V_{DDCO}$	digital supply voltage (core)		3.0	3.3	3.6	V
$I_{DD}$	digital supply current (I/O cells)		–	tbf	tbf	mA
$I_{DDCO}$	digital supply current (core)		–	tbf	tbf	mA
$I_{DD(tot)}$	total digital supply current		–	tbf	0.56	mA
$P_{tot}$	total power dissipation		–	tbf	2.0	W
<b>Inputs: YUV7 to YUV0, FID, HSYNC, VSYNC, VCLK, RESETN, MAD, FAD_RWN, FAD_EN, AS_ALE, DS_RDN, CS_TEST and TEST; note 1</b>						
$V_{IL}$	LOW-level input voltage		–0.5	–	+0.8	V
$V_{IH}$	HIGH-level input voltage	$V_{DD(max)} = 3.6$ V	2.0	–	5.5	V
$I_{IL}$	LOW-level input current	$V_{IL} = V_{SS}$	–	–	1	$\mu$ A
$I_{IH}$	HIGH-level input current	$V_{IH} = V_{DD}$	–1	–	–	$\mu$ A
$C_I$	input capacitance		–	–	10	pF
<b>Inputs: TRST, TCK, TMS, TDI, I_MN and CSN; notes 1 and 2</b>						
$V_{IL}$	LOW-level input voltage		–0.5	–	+0.8	V
$V_{IH}$	HIGH-level input voltage	$V_{DD(max)} = 3.6$ V	2.0	–	5.5	V
$I_{pu}$	pull-up input current	$V_{IL} = V_{SS}$	–	–	125	$\mu$ A
$I_{IH}$	HIGH-level input current	$V_{IH} = V_{DD}$	–10	–	–	$\mu$ A
$C_I$	input capacitance		–	–	10	pF
<b>Inputs/outputs (3-state): DATA63 to DATA0, AD15 to AD0, GPIO11 to GPIO0; note 1</b>						
$V_{IL}$	LOW-level input voltage		–0.5	–	+0.8	V
$V_{IH}$	HIGH-level input voltage	$V_{DD(max)} = 3.6$ V	2.0	–	5.5	V
$I_{IL}$	LOW-level input current	$V_{IL} = V_{SS}$	–	–	1	$\mu$ A
$I_{IH}$	HIGH-level input current	$V_{IH} = V_{DD}$	–1	–	–	$\mu$ A
$V_{OL}$	LOW-level output voltage	3 mA sink current	–	–	0.4	V
$V_{OH}$	HIGH-level output voltage	3 mA load current	2.4	–	$V_{DD}$	V
$I_{TL}$	3-state leakage current	$V_{IH} = V_{DD}$ ; $V_{IL} = V_{SS}$	–5	–	+5	$\mu$ A
$C_I$	input capacitance		–	–	10	pF
$C_L$	load capacitance		–	–	40	pF
<b>Output (3-state): TDO; note 3</b>						
$V_{OL}$	LOW-level output voltage	3 mA sink current	–	–	0.4	V
$V_{OH}$	HIGH-level output voltage	3 mA load current	2.4	–	$V_{DD}$	V
$I_{TL}$	3-state leakage current	$V_{IH} = V_{DD}$ ; $V_{IL} = V_{SS}$	–5	–	+5	$\mu$ A
$C_L$	load capacitance		–	–	40	pF



Encoder for MPEG2 image recording  
(EMPIRE)

SAA6750H

SYMBOL	PARAMETER	CONDITIONS	MIN.	TYP.	MAX.	UNIT
<b>Outputs (3-state): ADR8 to ADR0, CASN, RASN, WEN and OEN; note 3</b>						
V <sub>OL</sub>	LOW-level output voltage	3 mA sink current; CASN: 6 mA sink current	–	–	0.4	V
V <sub>OH</sub>	HIGH-level output voltage	3 mA load current; CASN: 6 mA load current	2.4	–	V <sub>DD</sub>	V
I <sub>TL</sub>	3-state leakage current	V <sub>IH</sub> = V <sub>DD</sub> ; V <sub>IL</sub> = V <sub>SS</sub>	–5	–	+5	μA
C <sub>L</sub>	load capacitance	any pin except CASN	–	–	40	pF
		only CASN pin	–	–	60	pF
<b>Outputs (open drain): LRQN, URQN, DTACK_RDY and FAD_RDY; note 4</b>						
V <sub>OL</sub>	LOW-level output voltage; open drain	3 mA sink current	–	–	0.4	V
V <sub>OH</sub>	HIGH-level output voltage; open drain		2.4	–	V <sub>DD</sub>	V
I <sub>SL</sub>	switch-off leakage current	V <sub>OH</sub> = V <sub>DD</sub>	–5	–	–	μA
C <sub>L</sub>	load capacitance		–	–	40	pF
<b>Video clock input timing: VCLK; see Fig.13</b>						
T <sub>cy</sub>	cycle time		35	37	39	ns
δ	duty factor	t <sub>HIGH</sub> /T <sub>cy</sub>	40	50	60	%
t <sub>r(VCLK)</sub>	rise time	V <sub>DD</sub> = 0.8 to 2.0 V	–	–	5	ns
t <sub>f(VCLK)</sub>	fall time	V <sub>DD</sub> = 2.0 to 0.8 V	–	–	6	ns
<b>Video input data and control input timing: YUV7 to YUV0, FID, HSYNC and VSYNC; see Fig.13</b>						
t <sub>SU; DAT</sub>	data set-up time		6	–	–	ns
t <sub>HD; DAT</sub>	data hold time		3	–	–	ns

Encoder for MPEG2 image recording  
(EMPIRE)

SAA6750H

SYMBOL	PARAMETER	CONDITIONS	MIN.	TYP.	MAX.	UNIT
<b>DRAM interface data, address and control timing: DATA63 to DATA0, ADR8 to ADR0, CASN, RASN, WEN and OEN; see Figs 14 to 16</b>						
t <sub>PC</sub>	fast page mode cycle time		60	2T <sub>cy</sub>	–	ns
t <sub>RP</sub>	RASN precharge time		60	2T <sub>cy</sub>	–	ns
t <sub>RRHCP</sub>	RASN hold time from CASN precharge		60	2T <sub>cy</sub>	–	ns
t <sub>RDH</sub>	read data hold time		0	–	–	ns
t <sub>CAS</sub>	CASN pulse width		30	T <sub>cy</sub>	45	ns
t <sub>CP</sub>	precharge time (page mode)		30	T <sub>cy</sub>	–	ns
t <sub>RCS</sub>	read command set-up time		60	2T <sub>cy</sub>	–	ns
t <sub>RCH</sub>	read command hold time referenced to CASN		30	T <sub>cy</sub>	–	ns
t <sub>WCS</sub>	WEN set-up time		60	2T <sub>cy</sub>	–	ns
t <sub>WCH</sub>	WEN hold time referenced to CASN		30	2T <sub>cy</sub>	–	ns
t <sub>RRH</sub>	read command hold time referenced to RASN		30	T <sub>cy</sub>	–	ns
t <sub>CSS</sub>	chip select OEN set-up time		60	2T <sub>cy</sub>	–	ns
t <sub>CSH</sub>	chip select OEN hold time referenced to CASN		0	–	–	ns
t <sub>ASR</sub>	row address set-up time		20	T <sub>cy</sub>	–	ns
t <sub>RAH</sub>	row address hold time		12	½T <sub>cy</sub>	–	ns
t <sub>ASC</sub>	column address set-up time		10	note 5	–	ns
t <sub>CAH</sub>	column address hold time		20	T <sub>cy</sub>	–	ns
t <sub>DS</sub>	data write set-up time		20	T <sub>cy</sub>	–	ns
t <sub>DH</sub>	data write hold time		20	T <sub>cy</sub>	–	ns
t <sub>RAC</sub>	access time from RASN		–	2T <sub>cy</sub>	60	ns
t <sub>CAC</sub>	access time from CASN		–	T <sub>cy</sub>	20	ns
t <sub>RCI</sub>	read/write cycle time in initialization mode		160	5T <sub>cy</sub>	–	ns
t <sub>RASI</sub>	RASN pulse width in initialization mode		100	3T <sub>cy</sub>	–	ns
t <sub>CSR</sub>	CASN set-up time		30	T <sub>cy</sub>	–	ns
t <sub>CHR</sub>	CASN hold time		30	T <sub>cy</sub>	–	ns
<b>Data output interface timing: DTACK_RDY, I_MN, CSN, AS_ALE, DS_RDN and AD15 to AD0; see Figs 12 to 20 and Table 13</b>						
t <sub>as</sub>	address set-up time		15	–	–	ns
t <sub>ah</sub>	address hold time		20	–	–	ns
t <sub>az</sub>	address 3-state time		20	–	–	ns
t <sub>cs</sub>	CSN set-up time		0	–	–	ns
t <sub>dhr</sub>	data hold time read		0	–	tbf	ns
t <sub>dsr</sub>	data set-up time read		0	–	–	ns
t <sub>rmin</sub>	RDY hold time		–	–	120	ns
t <sub>alh</sub>	ALE hold time		15	–	–	ns
t <sub>idl</sub>	ALE pulse width		85	–	–	ns
t <sub>rpw</sub>	RDY pulse width	note 6	T <sub>cy</sub>	2T <sub>cy</sub>	tbf	ns
t <sub>drtL</sub>	DTACK reaction time LOW	note 6	–	2T <sub>cy</sub>	tbf	ns

Encoder for MPEG2 image recording  
(EMPIRE)

SAA6750H

SYMBOL	PARAMETER	CONDITIONS	MIN.	TYP.	MAX.	UNIT
$t_{drtH}$	DTACK reaction time HIGH		–	$T_{cy}$	tbf	ns
$t_{rwi}$	read/write or data strobe pulse width		60	–	–	ns
$t_{dz}$	data 3-state		0	–	60	ns
<b>GPIO interface timing: FAD_RWN, FAD_EN, FAD_RDYN and GPIO11 to GPIO0; see Figs 21 and 22</b>						
$t_{dstW}$	GPIO-bus input data set-up time, WRITE		–	–	0	ns
<b>I<sup>2</sup>C-bus interface: SCL and SDA; note 7</b>						
$f_{SCL}$	clock frequency		100	–	400	kHz
$V_{IL}$	LOW-level input voltage		–	–	$0.3V_{DD}$	V
$V_{IH}$	HIGH-level input voltage		$0.7V_{DD}$	–	5.5	V
$I_I$	input current		–10	–	+10	$\mu$ A
$V_{OL}$	LOW-level output voltage; open drain	3 mA sink current	0	–	0.4	V
		6 mA sink current	0	–	0.6	V
$t_{LOW}$	timing LOW period of SCL clock		1.3	–	–	$\mu$ s
$t_{HIGH}$	timing HIGH period of SCL clock		0.6	–	–	$\mu$ s
$t_{r(I2C)}$	rise time of both SDA and SCL signals		–	–	0.3	$\mu$ s
$t_{f(I2C)}$	fall time of both SDA and SCL signals		–	–	0.3	$\mu$ s
$t_{SU;DAT}$	data set-up time		100	–	–	ns
$t_{HD;STA}$	hold time START condition		0.6	–	–	$\mu$ s
$t_{SU;STO}$	set-up time STOP condition		0.6	–	–	$\mu$ s

**Notes**

- All input pins are 5 V tolerant.
- In accordance with the "IEEE1149.1" standard the input pins TCK, TDI, TMS and TRST must have an internal pull-up resistor.
- The outputs, which can be switched in the 3-state mode, are 5 V tolerant due to the bus application of 5 V.
- The open drain outputs, which can be switched off, are 5 V tolerant due to the 5 V application.
- $\frac{1}{2}T_{cy}$  applies for first column address after a row address,  $T_{cy}$  for all other modes.
- Typical values are maximum when data is available.
- I/O pins of the I<sup>2</sup>C-bus interface must not obstruct the SDA and SCL lines if the supply voltage  $V_{DD}$  is switched off.

# Encoder for MPEG2 image recording (EMPIRE)

## SAA6750H

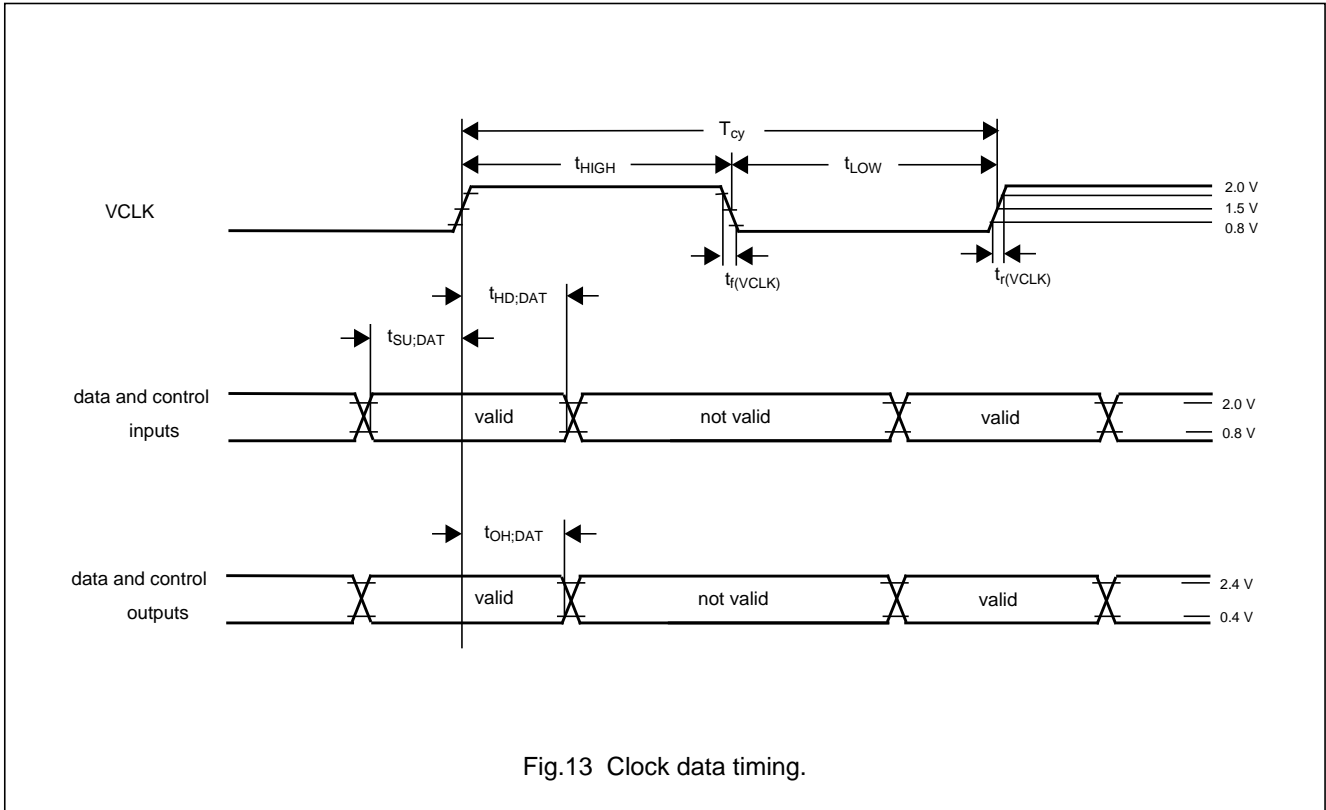

Encoder for MPEG2 image recording  
(EMPIRE)

SAA6750H

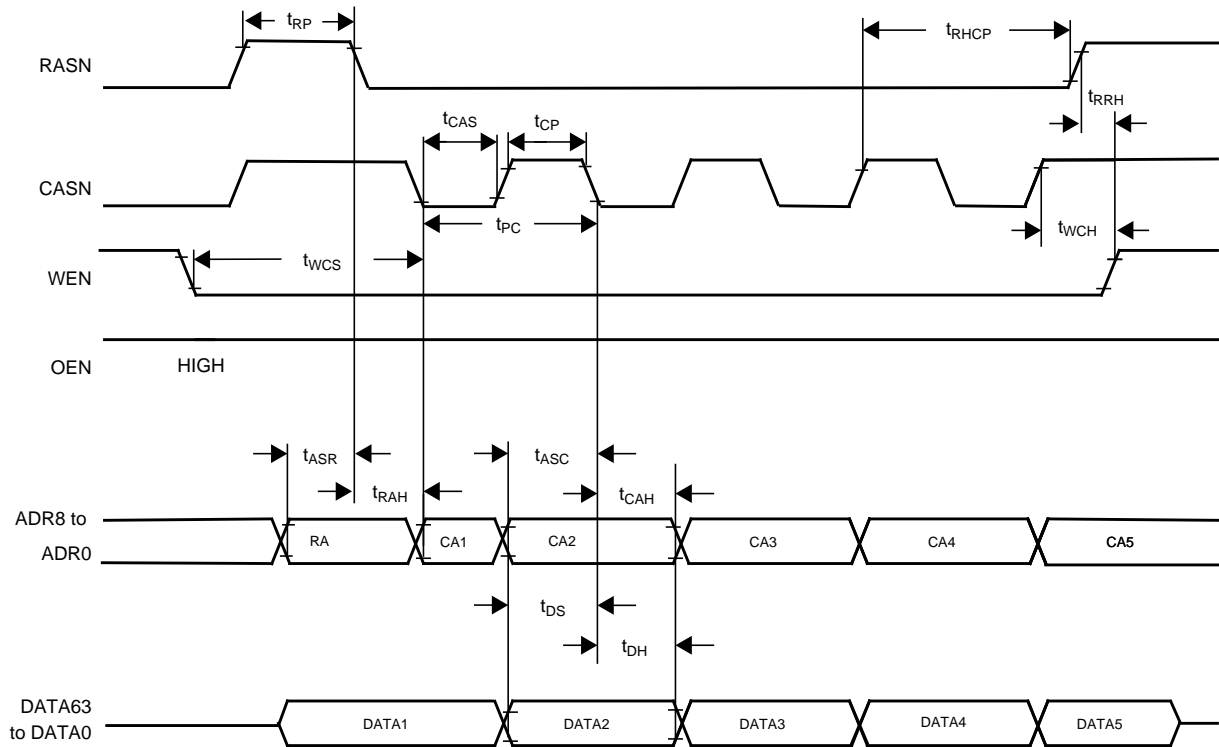

RA = row address.  
CA = column address.

Fig.14 DRAM fast page mode write cycles to external DRAM.

Encoder for MPEG2 image recording  
(EMPIRE)

SAA6750H

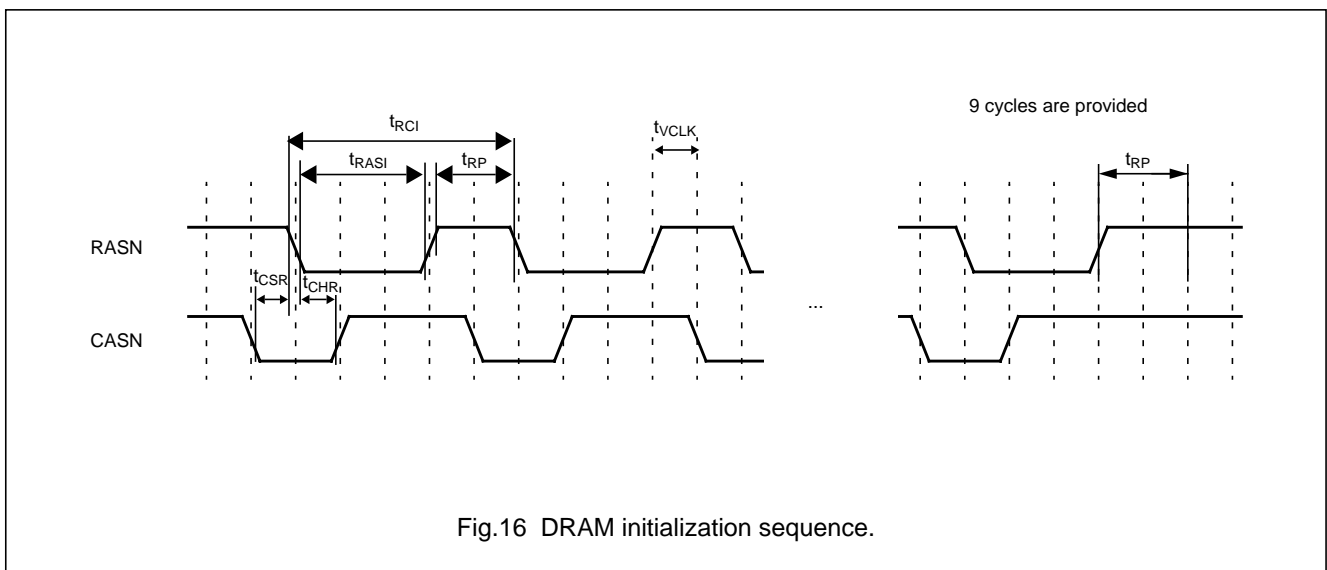
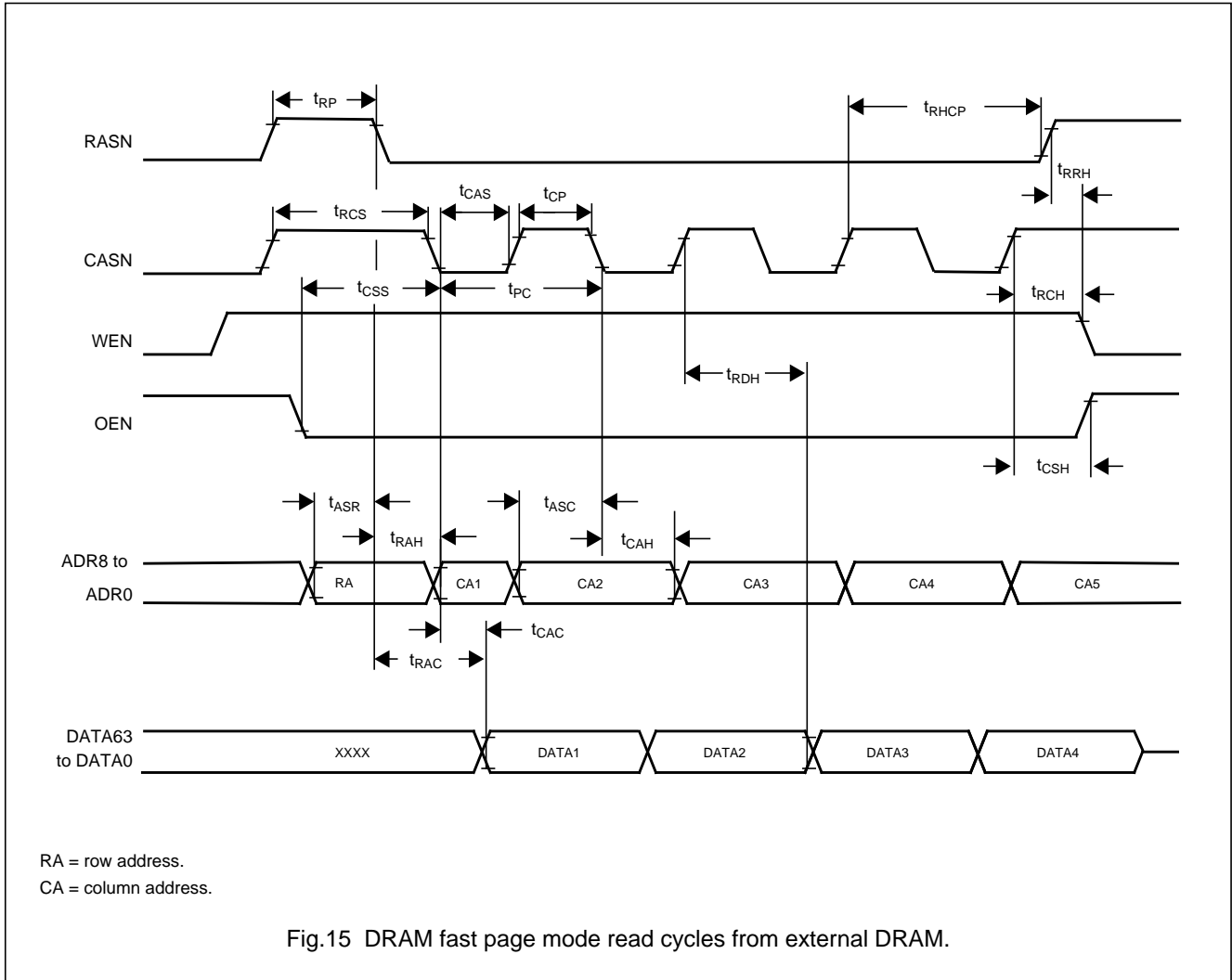

# Encoder for MPEG2 image recording (EMPIRE)

SAA6750H

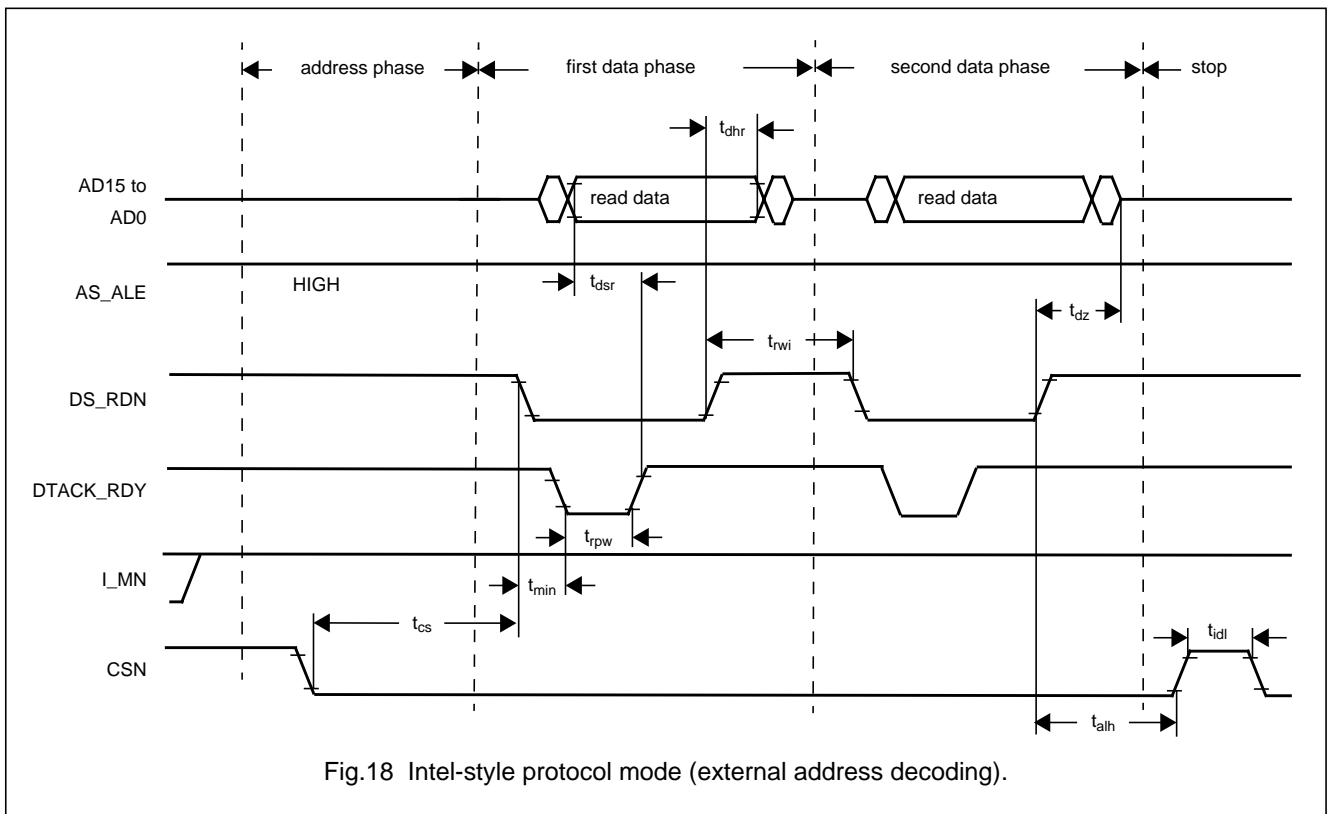
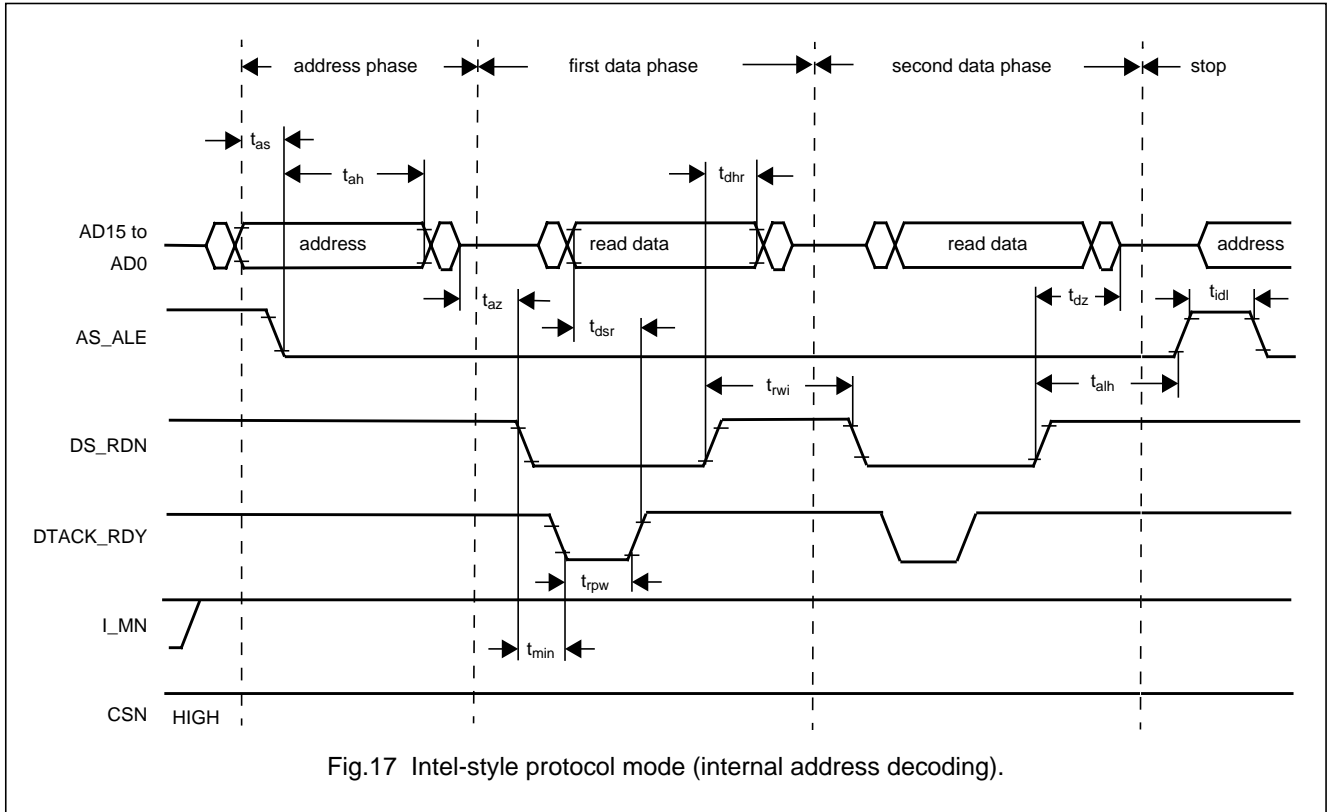

# Encoder for MPEG2 image recording (EMPIRE)

SAA6750H

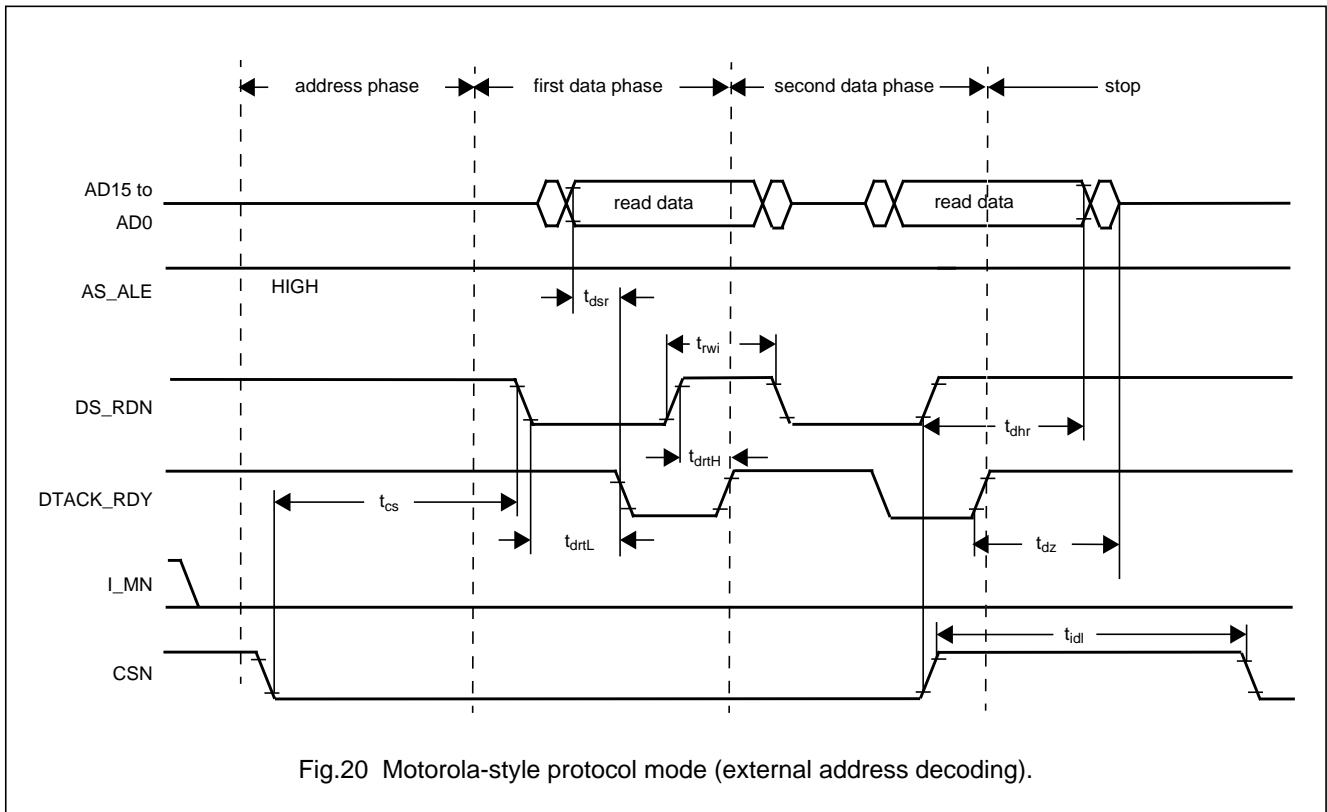
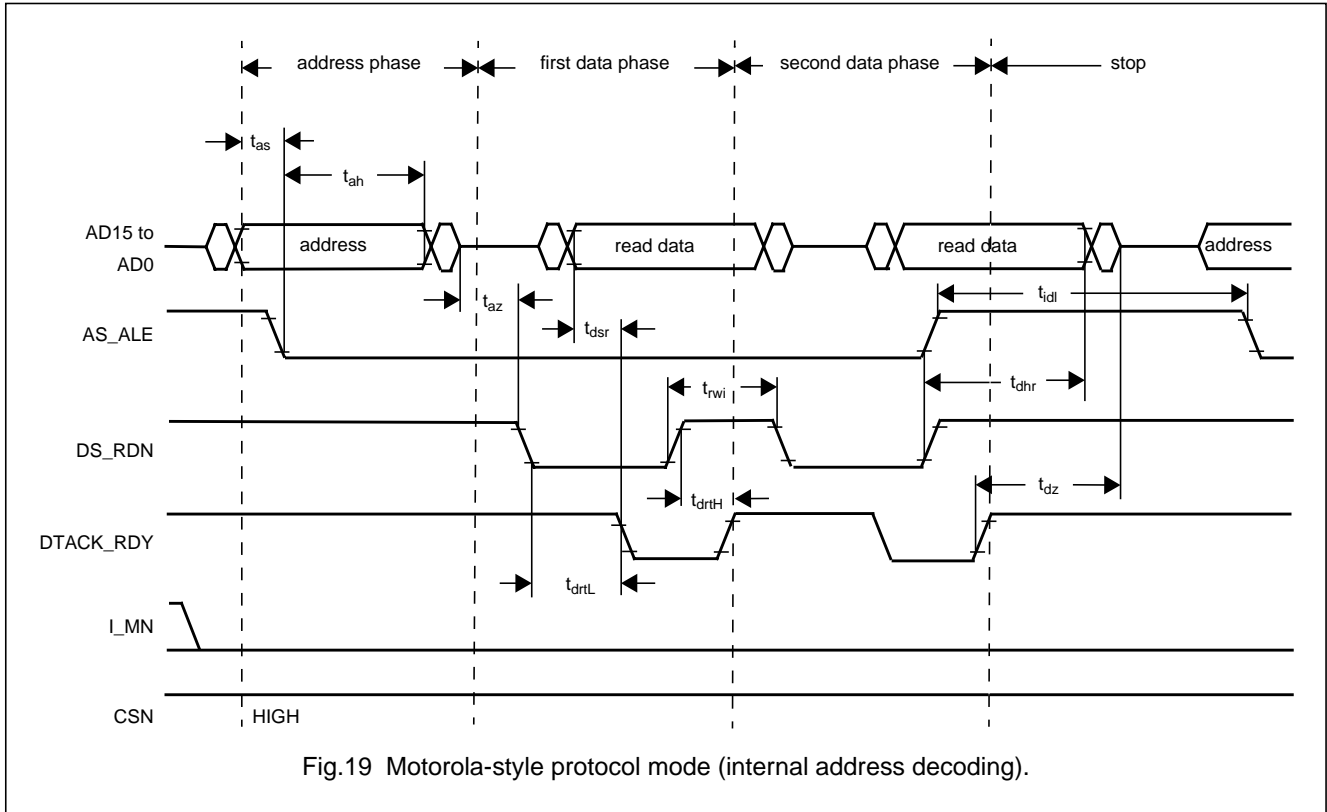



# Encoder for MPEG2 image recording (EMPIRE)

SAA6750H

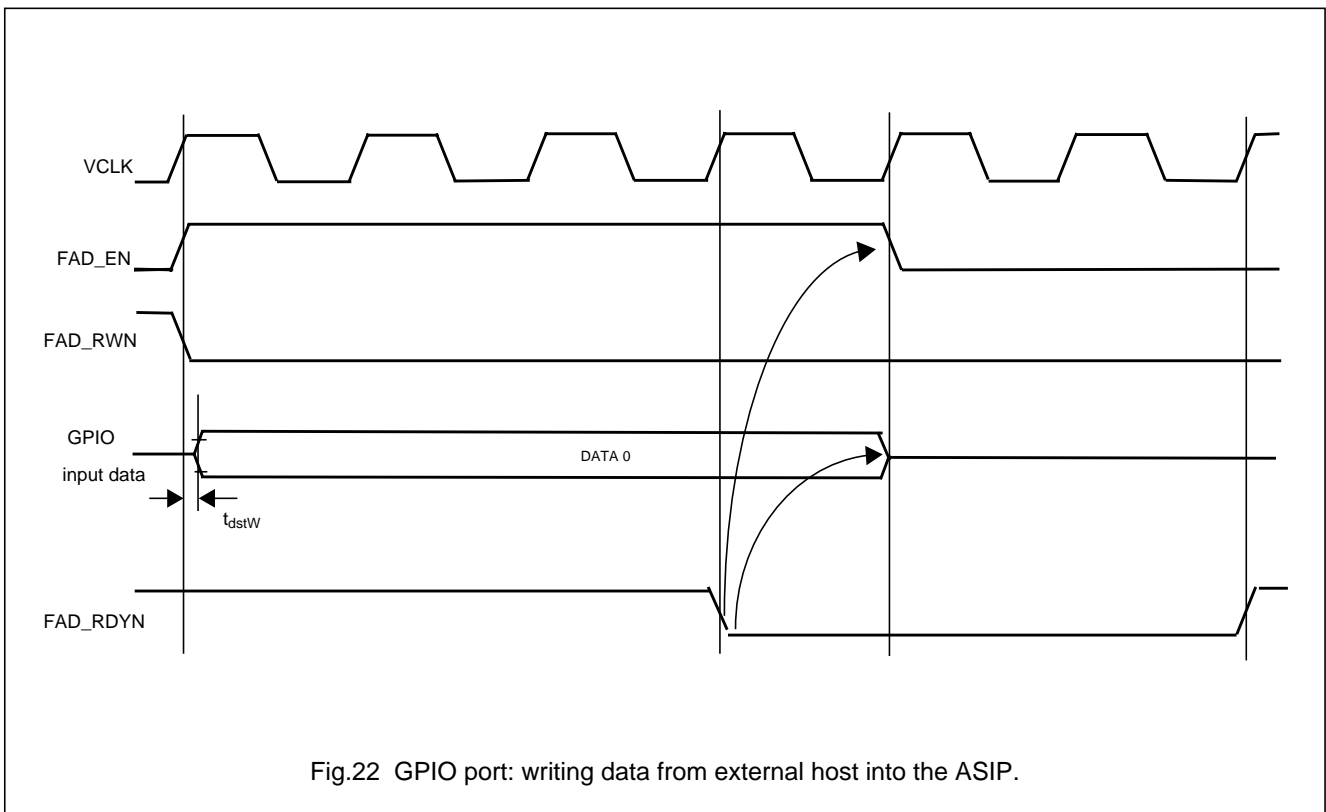
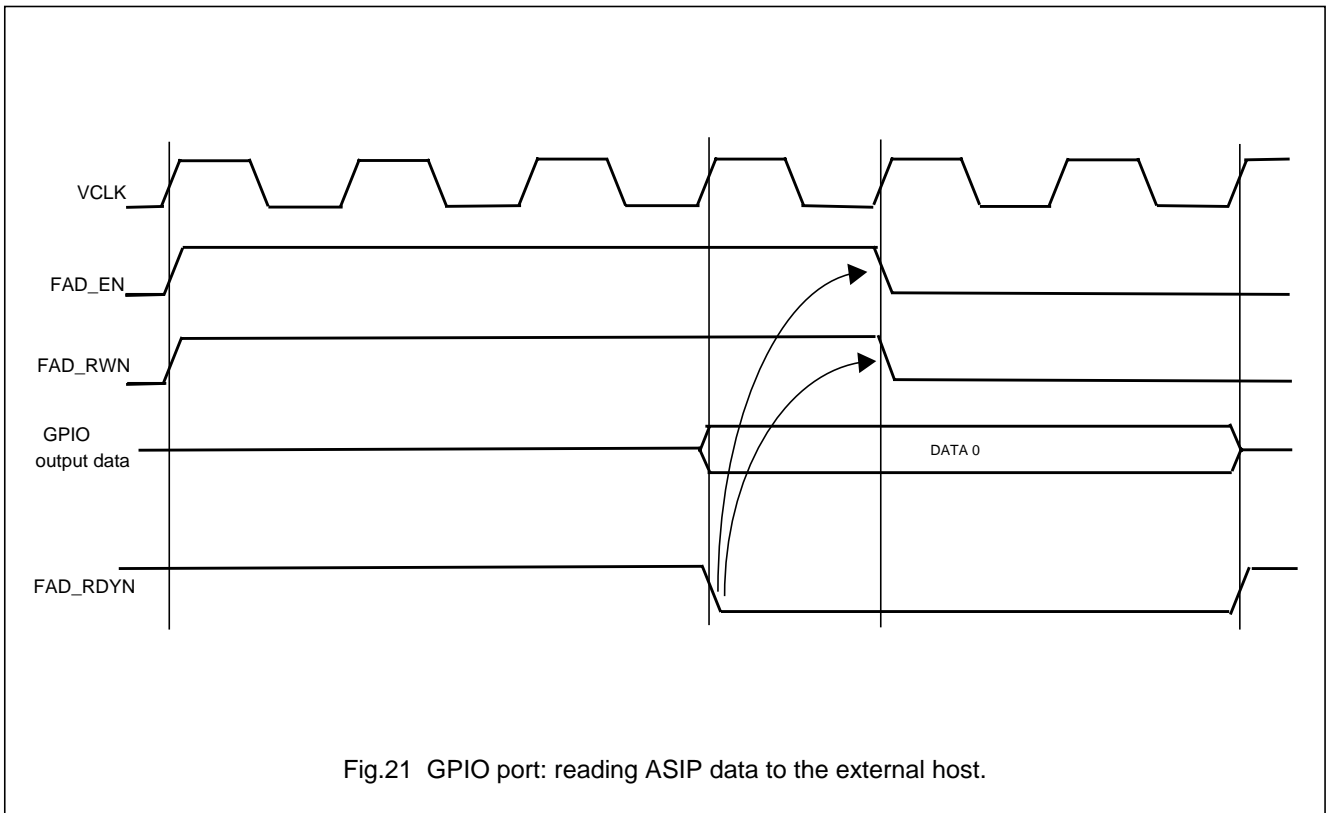

# Encoder for MPEG2 image recording (EMPIRE)

SAA6750H

## 11 APPLICATION INFORMATION

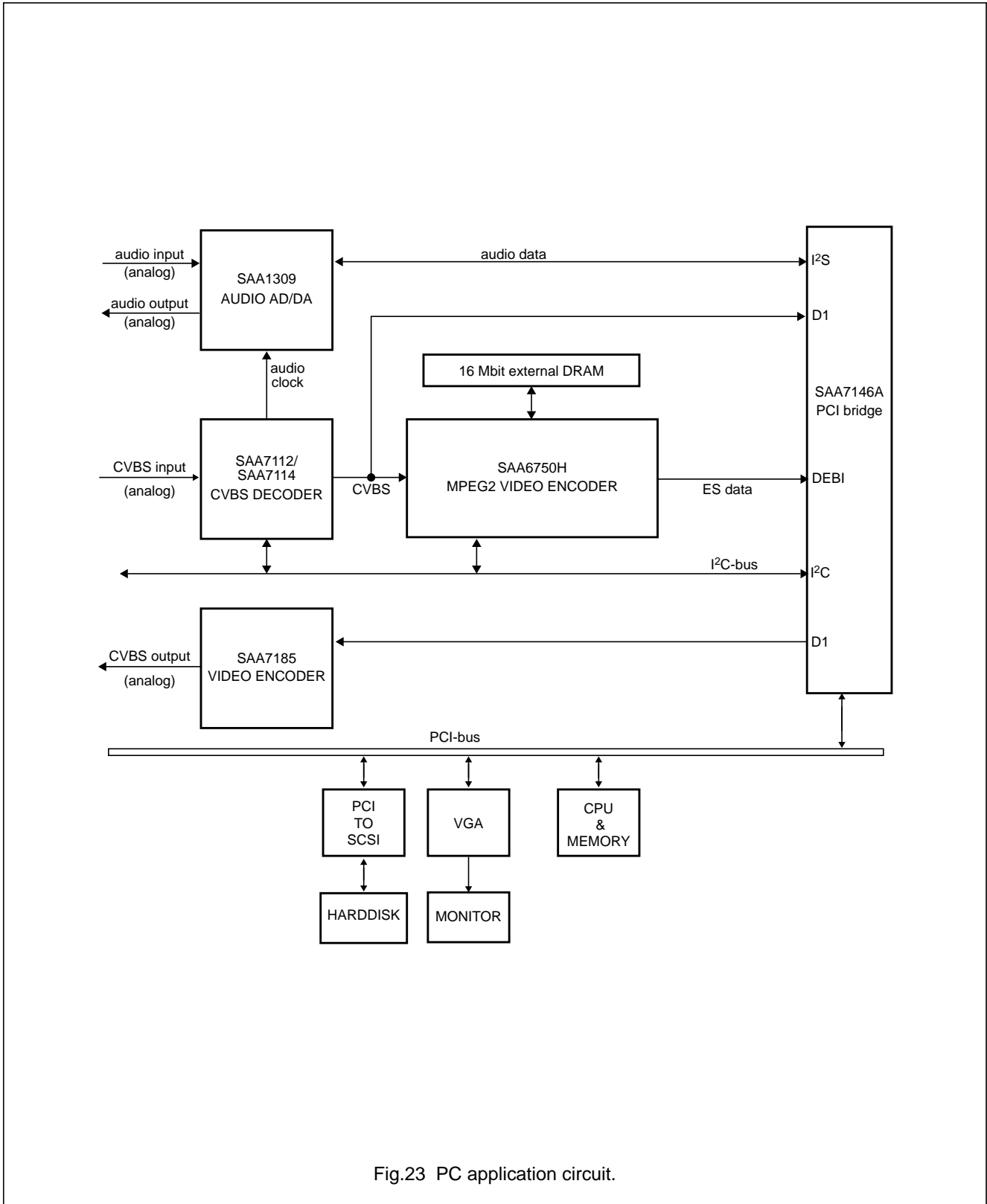

Fig.23 PC application circuit.

# Encoder for MPEG2 image recording (EMPIRE)

SAA6750H

## 12 PACKAGE OUTLINE

**SQFP208: plastic shrink quad flat package;**  
**208 leads (lead length 1.3 mm); body 28 x 28 x 3.4 mm**

SOT316-1

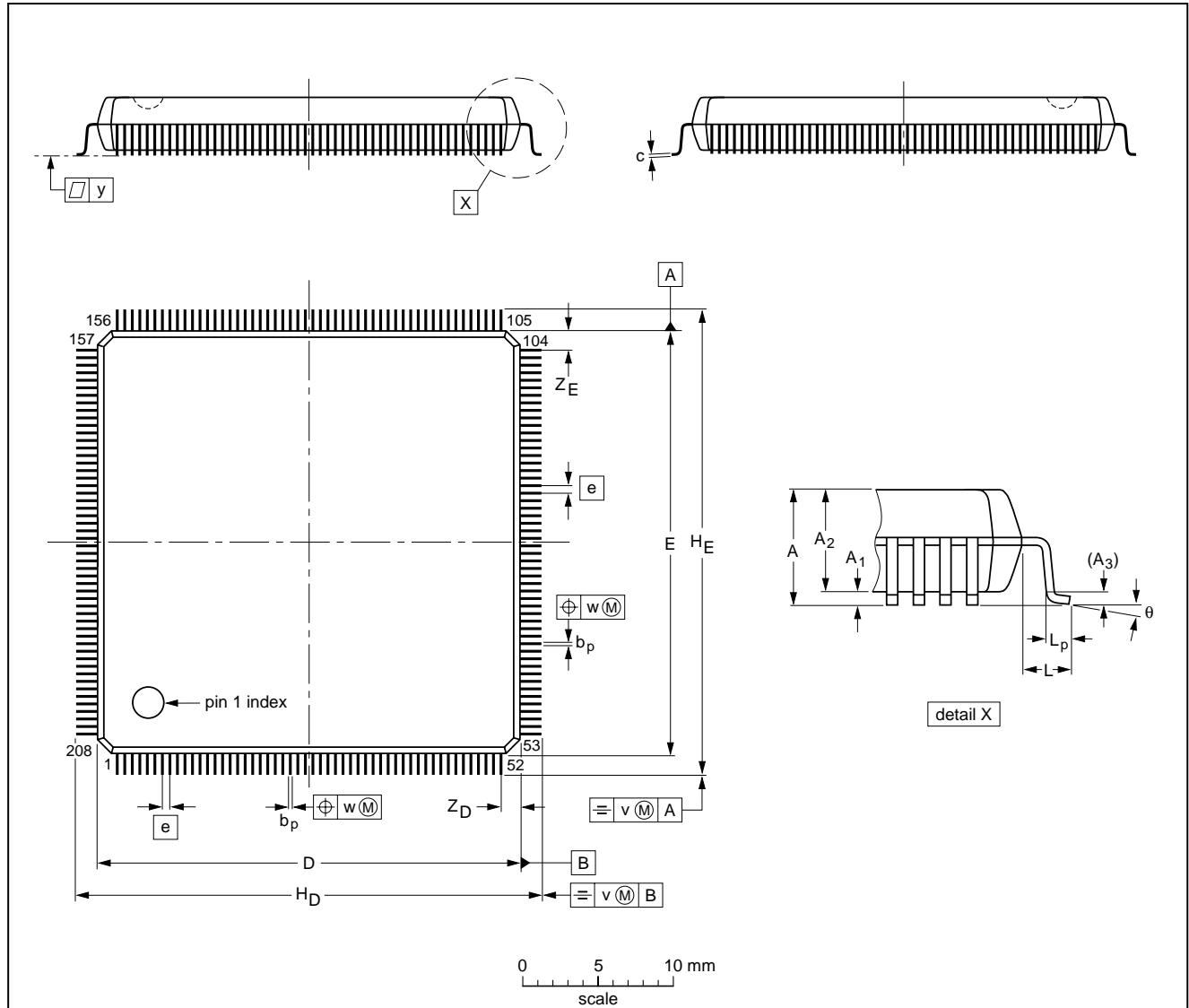

**DIMENSIONS (mm are the original dimensions)**

UNIT	A max.	A <sub>1</sub>	A <sub>2</sub>	A <sub>3</sub>	b <sub>p</sub>	c	D <sup>(1)</sup>	E <sup>(1)</sup>	e	H <sub>D</sub>	H <sub>E</sub>	L	L <sub>p</sub>	v	w	y	Z <sub>D</sub> <sup>(1)</sup>	Z <sub>E</sub> <sup>(1)</sup>	θ
mm	4.10	0.40 0.25	3.70 3.15	0.25	0.25 0.13	0.23 0.13	28.1 27.9	28.1 27.9	0.5	30.9 30.3	30.9 30.3	1.3	0.70 0.45	0.1	0.1	0.075	1.45 1.05	1.45 1.05	8° 0°

**Note**

1. Plastic or metal protrusions of 0.25 mm maximum per side are not included.

OUTLINE VERSION	REFERENCES				EUROPEAN PROJECTION	ISSUE DATE
	IEC	JEDEC	EIAJ			
SOT316-1						97-04-08 97-08-01

---

## Encoder for MPEG2 image recording (EMPIRE)

---

SAA6750H

### 13 SOLDERING

#### 13.1 Introduction

There is no soldering method that is ideal for all IC packages. Wave soldering is often preferred when through-hole and surface mounted components are mixed on one printed-circuit board. However, wave soldering is not always suitable for surface mounted ICs, or for printed-circuits with high population densities. In these situations reflow soldering is often used.

This text gives a very brief insight to a complex technology. A more in-depth account of soldering ICs can be found in our *"Data Handbook IC26; Integrated Circuit Packages"* (order code 9398 652 90011).

#### 13.2 Reflow soldering

Reflow soldering techniques are suitable for all SQFP packages.

Reflow soldering requires solder paste (a suspension of fine solder particles, flux and binding agent) to be applied to the printed-circuit board by screen printing, stencilling or pressure-syringe dispensing before package placement.

Several methods exist for reflowing; for example, infrared/convection heating in a conveyor type oven. Throughput times (preheating, soldering and cooling) vary between 50 and 300 seconds depending on heating method. Typical reflow peak temperatures range from 215 to 250 °C.

#### 13.3 Wave soldering

SQFP packages are **not** suitable for wave soldering, this is because of the likelihood of solder bridging due to closely-spaced leads and the possibility of incomplete solder penetration in multi-lead devices.

#### 13.4 Repairing soldered joints

Fix the component by first soldering two diagonally-opposite end leads. Use only a low voltage soldering iron (less than 24 V) applied to the flat part of the lead. Contact time must be limited to 10 seconds at up to 300 °C. When using a dedicated tool, all other leads can be soldered in one operation within 2 to 5 seconds between 270 and 320 °C.

Encoder for MPEG2 image recording  
(EMPIRE)

SAA6750H

14 DEFINITIONS

<b>Data sheet status</b>	
Objective specification	This data sheet contains target or goal specifications for product development.
Preliminary specification	This data sheet contains preliminary data; supplementary data may be published later.
Product specification	This data sheet contains final product specifications.
<b>Limiting values</b>	
Limiting values given are in accordance with the Absolute Maximum Rating System (IEC 134). Stress above one or more of the limiting values may cause permanent damage to the device. These are stress ratings only and operation of the device at these or at any other conditions above those given in the Characteristics sections of the specification is not implied. Exposure to limiting values for extended periods may affect device reliability.	
<b>Application information</b>	
Where application information is given, it is advisory and does not form part of the specification.	

15 LIFE SUPPORT APPLICATIONS

These products are not designed for use in life support appliances, devices, or systems where malfunction of these products can reasonably be expected to result in personal injury. Philips customers using or selling these products for use in such applications do so at their own risk and agree to fully indemnify Philips for any damages resulting from such improper use or sale.

16 PURCHASE OF PHILIPS I<sup>2</sup>C COMPONENTS



Purchase of Philips I<sup>2</sup>C components conveys a license under the Philips' I<sup>2</sup>C patent to use the components in the I<sup>2</sup>C system provided the system conforms to the I<sup>2</sup>C specification defined by Philips. This specification can be ordered using the code 9398 393 40011.

---

Encoder for MPEG2 image recording  
(EMPIRE)

---

SAA6750H

NOTES

---

Encoder for MPEG2 image recording  
(EMPIRE)

---

SAA6750H

**NOTES**

# Philips Semiconductors – a worldwide company

**Argentina:** see South America

**Australia:** 34 Waterloo Road, NORTH RYDE, NSW 2113,  
Tel. +61 2 9805 4455, Fax. +61 2 9805 4466

**Austria:** Computerstr. 6, A-1101 WIEN, P.O. Box 213, Tel. +43 160 1010,  
Fax. +43 160 101 1210

**Belarus:** Hotel Minsk Business Center, Bld. 3, r. 1211, Volodarski Str. 6,  
220050 MINSK, Tel. +375 172 200 733, Fax. +375 172 200 773

**Belgium:** see The Netherlands

**Brazil:** see South America

**Bulgaria:** Philips Bulgaria Ltd., Energoproject, 15th floor,  
51 James Bourchier Blvd., 1407 SOFIA,  
Tel. +359 2 689 211, Fax. +359 2 689 102

**Canada:** PHILIPS SEMICONDUCTORS/COMPONENTS,  
Tel. +1 800 234 7381

**China/Hong Kong:** 501 Hong Kong Industrial Technology Centre,  
72 Tat Chee Avenue, Kowloon Tong, HONG KONG,  
Tel. +852 2319 7888, Fax. +852 2319 7700

**Colombia:** see South America

**Czech Republic:** see Austria

**Denmark:** Prags Boulevard 80, PB 1919, DK-2300 COPENHAGEN S,  
Tel. +45 32 88 2636, Fax. +45 31 57 0044

**Finland:** Sinikalliontie 3, FIN-02630 ESPOO,  
Tel. +358 9 615800, Fax. +358 9 61580920

**France:** 51 Rue Carnot, BP317, 92156 SURESNES Cedex,  
Tel. +33 1 40 99 6161, Fax. +33 1 40 99 6427

**Germany:** Hammerbrookstraße 69, D-20097 HAMBURG,  
Tel. +49 40 23 53 60, Fax. +49 40 23 536 300

**Greece:** No. 15, 25th March Street, GR 17778 TAVROS/ATHENS,  
Tel. +30 1 4894 339/239, Fax. +30 1 4814 240

**Hungary:** see Austria

**India:** Philips INDIA Ltd, Band Box Building, 2nd floor,  
254-D, Dr. Annie Besant Road, Worli, MUMBAI 400 025,  
Tel. +91 22 493 8541, Fax. +91 22 493 0966

**Indonesia:** PT Philips Development Corporation, Semiconductors Division,  
Gedung Philips, Jl. Buncit Raya Kav.99-100, JAKARTA 12510,  
Tel. +62 21 794 0040 ext. 2501, Fax. +62 21 794 0080

**Ireland:** Newstead, Clonskeagh, DUBLIN 14,  
Tel. +353 1 7640 000, Fax. +353 1 7640 200

**Israel:** RAPAC Electronics, 7 Kehilat Saloniki St, PO Box 18053,  
TEL AVIV 61180, Tel. +972 3 645 0444, Fax. +972 3 649 1007

**Italy:** PHILIPS SEMICONDUCTORS, Piazza IV Novembre 3,  
20124 MILANO, Tel. +39 2 6752 2531, Fax. +39 2 6752 2557

**Japan:** Philips Bldg 13-37, Kohnan 2-chome, Minato-ku,  
TOKYO 108-8507, Tel. +81 3 3740 5130, Fax. +81 3 3740 5077

**Korea:** Philips House, 260-199 Itaewon-dong, Yongsan-ku, SEOUL,  
Tel. +82 2 709 1412, Fax. +82 2 709 1415

**Malaysia:** No. 76 Jalan Universiti, 46200 PETALING JAYA, SELANGOR,  
Tel. +60 3 750 5214, Fax. +60 3 757 4880

**Mexico:** 5900 Gateway East, Suite 200, EL PASO, TEXAS 79905,  
Tel. +9-5 800 234 7381

**Middle East:** see Italy

**Netherlands:** Postbus 90050, 5600 PB EINDHOVEN, Bldg. VB,  
Tel. +31 40 27 82785, Fax. +31 40 27 88399

**New Zealand:** 2 Wagener Place, C.P.O. Box 1041, AUCKLAND,  
Tel. +64 9 849 4160, Fax. +64 9 849 7811

**Norway:** Box 1, Manglerud 0612, OSLO,  
Tel. +47 22 74 8000, Fax. +47 22 74 8341

**Pakistan:** see Singapore

**Philippines:** Philips Semiconductors Philippines Inc.,  
106 Valero St. Salcedo Village, P.O. Box 2108 MCC, MAKATI,  
Metro MANILA, Tel. +63 2 816 6380, Fax. +63 2 817 3474

**Poland:** Ul. Lukiska 10, PL 04-123 WARSZAWA,  
Tel. +48 22 612 2831, Fax. +48 22 612 2327

**Portugal:** see Spain

**Romania:** see Italy

**Russia:** Philips Russia, Ul. Usatcheva 35A, 119048 MOSCOW,  
Tel. +7 095 755 6918, Fax. +7 095 755 6919

**Singapore:** Lorong 1, Toa Payoh, SINGAPORE 319762,  
Tel. +65 350 2538, Fax. +65 251 6500

**Slovakia:** see Austria

**Slovenia:** see Italy

**South Africa:** S.A. PHILIPS Pty Ltd., 195-215 Main Road Martindale,  
2092 JOHANNESBURG, P.O. Box 7430 Johannesburg 2000,  
Tel. +27 11 470 5911, Fax. +27 11 470 5494

**South America:** Al. Vicente Pinzon, 173, 6th floor,  
04547-130 SÃO PAULO, SP, Brazil,  
Tel. +55 11 821 2333, Fax. +55 11 821 2382

**Spain:** Balmes 22, 08007 BARCELONA,  
Tel. +34 93 301 6312, Fax. +34 93 301 4107

**Sweden:** Kottbygatan 7, Akalla, S-16485 STOCKHOLM,  
Tel. +46 8 5985 2000, Fax. +46 8 5985 2745

**Switzerland:** Allmendstrasse 140, CH-8027 ZÜRICH,  
Tel. +41 1 488 2741 Fax. +41 1 488 3263

**Taiwan:** Philips Semiconductors, 6F, No. 96, Chien Kuo N. Rd., Sec. 1,  
TAIPEI, Taiwan Tel. +886 2 2134 2865, Fax. +886 2 2134 2874

**Thailand:** PHILIPS ELECTRONICS (THAILAND) Ltd.,  
209/2 Sanpavuth-Bangna Road Prakanong, BANGKOK 10260,  
Tel. +66 2 745 4090, Fax. +66 2 398 0793

**Turkey:** Talatpasa Cad. No. 5, 80640 GÜLTEPE/ISTANBUL,  
Tel. +90 212 279 2770, Fax. +90 212 282 6707

**Ukraine:** PHILIPS UKRAINE, 4 Patrice Lumumba str., Building B, Floor 7,  
252042 KIEV, Tel. +380 44 264 2776, Fax. +380 44 268 0461

**United Kingdom:** Philips Semiconductors Ltd., 276 Bath Road, Hayes,  
MIDDLESEX UB3 5BX, Tel. +44 181 730 5000, Fax. +44 181 754 8421

**United States:** 811 East Arques Avenue, SUNNYVALE, CA 94088-3409,  
Tel. +1 800 234 7381

**Uruguay:** see South America

**Vietnam:** see Singapore

**Yugoslavia:** PHILIPS, Trg N. Pasica 5/v, 11000 BEOGRAD,  
Tel. +381 11 625 344, Fax. +381 11 635 777

**For all other countries apply to:** Philips Semiconductors,  
International Marketing & Sales Communications, Building BE-p, P.O. Box 218,  
5600 MD EINDHOVEN, The Netherlands, Fax. +31 40 27 24825

**Internet:** <http://www.semiconductors.philips.com>

© Philips Electronics N.V. 1998

SCA60

All rights are reserved. Reproduction in whole or in part is prohibited without the prior written consent of the copyright owner.

The information presented in this document does not form part of any quotation or contract, is believed to be accurate and reliable and may be changed without notice. No liability will be accepted by the publisher for any consequence of its use. Publication thereof does not convey nor imply any license under patent- or other industrial or intellectual property rights.

Printed in The Netherlands

545104/750/01/pp64

Date of release: 1998 Sep 07

Document order number: 9397 750 03345

*Let's make things better.*

**Philips**  
Semiconductors



**PHILIPS**