

# DATA SHEET

## **PCF2113x** LCD controller/driver

Product specification  
Supersedes data of 1996 Oct 21  
File under Integrated Circuits, IC12

1997 Apr 04

**LCD controller/driver****PCF2113x****CONTENTS**

1	FEATURES	10.1	New instructions
2	APPLICATIONS	10.2	Icon control
3	GENERAL DESCRIPTION	10.3	IM
4	ORDERING INFORMATION	10.4	IB
5	BLOCK DIAGRAM	10.5	Normal/Icon mode operation
6	PINNING	10.6	Screen configuration
7	PIN FUNCTIONS	10.7	Display configuration
8	FUNCTIONAL DESCRIPTION	10.8	TC1, TC2
8.1	LCD supply voltage generator	10.9	Set $V_{LCD}$
8.2	Programming ranges	10.10	Reducing current consumption
8.3	LCD bias voltage generator	11	INTERFACE TO MICROCONTROLLER (PARALLEL INTERFACE)
8.4	Oscillator	12	INTERFACE TO MICROCONTROLLER (I <sup>2</sup> C-BUS INTERFACE)
8.5	External clock	12.1	Characteristics of the I <sup>2</sup> C-bus
8.6	Power-on reset	12.2	I <sup>2</sup> C-bus protocol
8.7	Power-down mode	12.3	Definitions
8.8	Registers	13	LIMITING VALUES
8.9	Busy Flag	14	HANDLING
8.10	Address Counter (AC)	15	DC CHARACTERISTICS
8.11	Display Data RAM (DDRAM)	16	AC CHARACTERISTICS
8.12	Character Generator ROM (CGROM)	17	TIMING CHARACTERISTICS
8.13	Character Generator RAM (CGRAM)	18	APPLICATION INFORMATION
8.14	Cursor control circuit	18.1	8-bit operation, 1-line display using internal reset
8.15	Timing generator	18.2	4-bit operation, 1-line display using internal reset
8.16	LCD row and column drivers	18.3	8-bit operation, 2-line display
8.17	Reset function	18.4	I <sup>2</sup> C operation, 1-line display
9	INSTRUCTIONS	19	BONDING PAD LOCATIONS
9.1	Clear display	20	PACKAGE OUTLINE
9.2	Return home	21	SOLDERING
9.3	Entry mode set	21.1	Introduction
9.3.1	I/D	21.2	Reflow soldering
9.3.2	S	21.3	Wave soldering
9.4	Display control (and partial power-down mode)	21.4	Repairing soldered joints
9.4.1	D	22	DEFINITIONS
9.4.2	C	23	LIFE SUPPORT APPLICATIONS
9.4.3	B	24	PURCHASE OF PHILIPS I <sup>2</sup> C COMPONENTS
9.5	Cursor/display shift		
9.6	Function set		
9.6.1	DL (parallel mode only)		
9.6.2	M		
9.6.3	H		
9.7	Set CGRAM address		
9.8	Set DDRAM address		
9.9	Read busy flag and address		
9.10	Write data to CGRAM or DDRAM		
9.11	Read data from CGRAM or DDRAM		
10	EXTENDED FUNCTION SET INSTRUCTIONS AND FEATURES		



## LCD controller/driver

## PCF2113x

**1 FEATURES**

- Single-chip LCD controller/driver
- 2-line display of up to 12 characters + 120 icons, or 1-line display of up to 24 characters + 120 icons
- 5 × 7 character format plus cursor; 5 × 8 for kana (Japanese syllabary) and user defined symbols
- Icon mode: reduced current consumption while displaying icons only<sup>(1)</sup>
- Icon blink function
- On-chip:
  - generation of LCD supply voltage, programmable by instruction (external supply also possible)
  - temperature compensation of on-chip generated  $V_{LCD}$ : -8 to -12 mV/K at 5.0 V (programmable by instruction)
  - generation of intermediate LCD bias voltages
  - oscillator requires no external components (external clock also possible)
- Display data RAM: 80 characters
- Character generator ROM: 240, 5 × 8 characters
- Character generator RAM: 16, 5 × 8 characters; 3 characters used to drive 120 icons, 6 characters used if icon-blink feature is used in application
- 4 or 8-bit parallel bus and 2-wire I<sup>2</sup>C-bus interface
- CMOS compatible
- 18 row, 60 column outputs

(1) Icon mode is used to save current. When only icons are displayed, a much lower operating voltage  $V_{LCD}$  can be used and the switching frequency of the LCD outputs is reduced. In most applications it is possible to use  $V_{DD}$  as  $V_{LCD}$ . Never use the voltage generator in icon mode.

- MUX rates 1 : 18 (for normal operation) and 1 : 2 (for icon-only mode)
- Uses common 11 code instruction set (extended)
- Logic supply voltage range,  $V_{DD} - V_{SS} = 1.8$  to 4.0 V (up to 5.5 V if external  $V_{LCD}$  is used); chip may be driven with two battery cells
- Display supply voltage range,  $V_{LCD} - V_{SS} = 2.2$  to 6.5 V
- Very low current consumption (20 to 200  $\mu$ A):
  - icon mode: <25  $\mu$ A
  - power-down mode: <2.5  $\mu$ A.

**2 APPLICATIONS**

- Telecom equipment
- Portable instruments
- Point-of-sale terminals.

**3 GENERAL DESCRIPTION**

The PCF2113x is a low power CMOS LCD controller and driver, designed to drive a dot matrix LCD display of 2 line by 12 and 1 line by 24 characters with 5 × 8 dot format. All necessary functions for the display are provided in a single chip, including on-chip generation of LCD bias voltages, resulting in a minimum of external components and lower system current consumption. The PCF2113x interfaces to most microcontrollers via a 4 or 8-bit bus or via the 2-wire I<sup>2</sup>C-bus. The chip contains a character generator and displays alphanumeric and kana (Japanese) characters. Three character sets (A, D and E) are currently available (see Figs 7, 8 and 9). Various other character sets can be manufactured on request.

**4 ORDERING INFORMATION**

TYPE NUMBER	PACKAGE		VERSION
	NAME	DESCRIPTION	
PCF2113AU/10/F2	–	chip on flexible film carrier	–
PCF2113DU/10/F2	–	chip on flexible film carrier	–
PCF2113DU/F2	–	chip in tray	–
PCF2113DH/F2	LQFP100	plastic low profile quad flat package; 100 leads; body 14 × 14 × 1.4 mm	SOT407-1
PCF2113EU/2/F2	–	chip with bumps in tray	–

LCD controller/driver

PCF2113x

5 BLOCK DIAGRAM

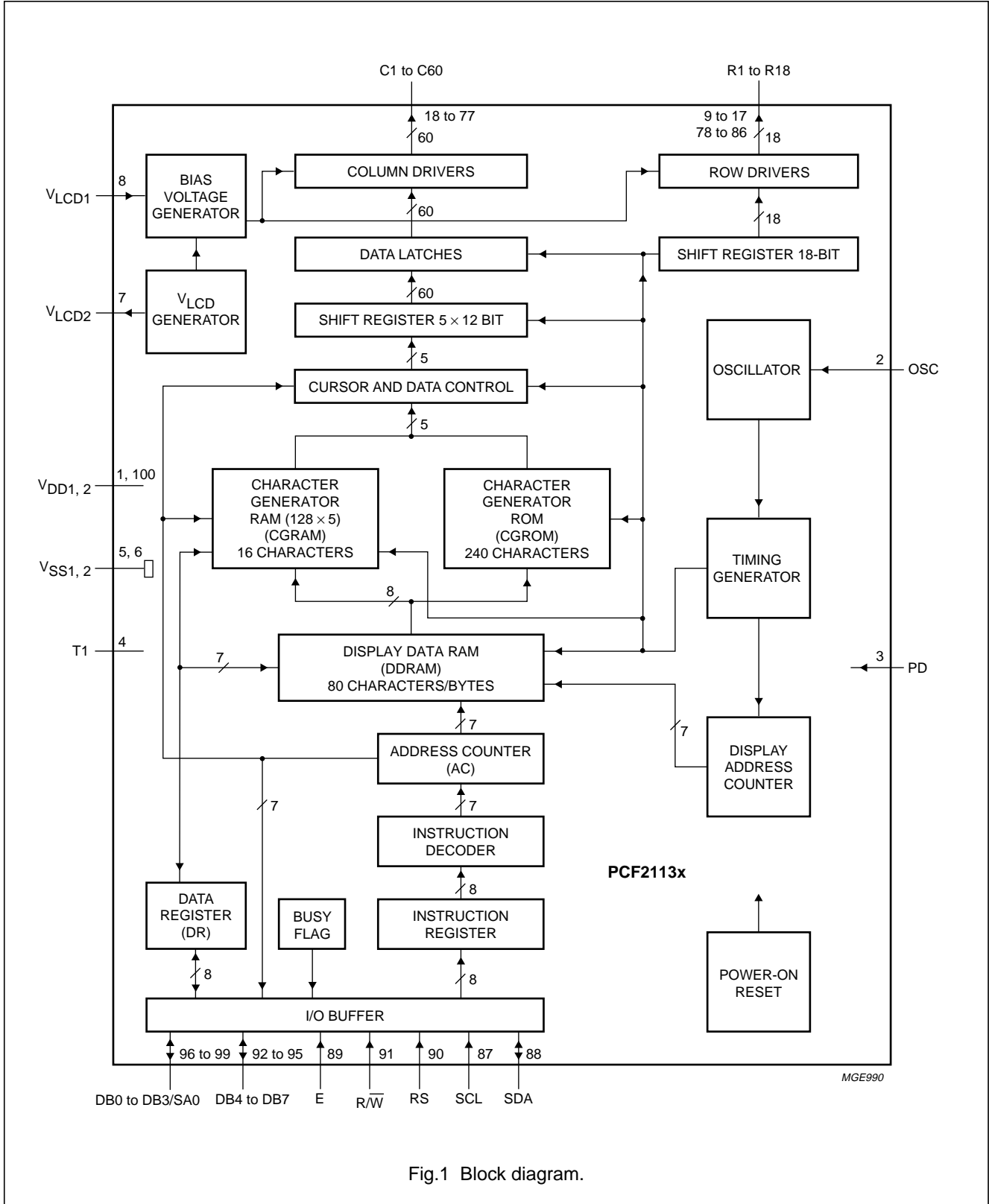

Fig.1 Block diagram.

## LCD controller/driver

## PCF2113x

## 6 PINNING

SYMBOL	PIN	TYPE	DESCRIPTION
V <sub>DD1</sub>	1	P	supply voltage for all except high voltage generator
OSC	2	I	oscillator/external clock input
PD	3	I	power-down pad input
T1	4	I	test pad (connected to V <sub>SS</sub> )
V <sub>SS1</sub>	5	P	ground for all except high voltage generator
V <sub>SS2</sub>	6	P	ground for high voltage generator
V <sub>LCD2</sub>	7	O	V <sub>LCD</sub> output; note 1
V <sub>LCD1</sub>	8	I	V <sub>LCD</sub> input; note 2
R9 to R16	9 to 16	O	LCD row driver outputs 9 to 16
R18	17	O	LCD row driver output 18
C60 to C1	18 to 77	O	LCD column driver outputs 60 to 1
R8 to R1	78 to 85	O	LCD row driver outputs 8 to 1
R17	86	O	LCD row driver output 17
SCL	87	I	I <sup>2</sup> C serial clock input
SDA	88	I/O	I <sup>2</sup> C serial data input/output
E	89	I	data bus clock input
RS	90	I	register select input
R/ $\bar{W}$	91	I	read/write input
DB7	92	I/O	1 bit of 8-bit bidirectional data bus
DB6	93	I/O	1 bit of 8-bit bidirectional data bus
DB5	94	I/O	1 bit of 8-bit bidirectional data bus
DB4	95	I/O	1 bit of 8-bit bidirectional data bus
DB3/SA0	96	I/O	1 bit of 8-bit bi-directional data bus/I <sup>2</sup> C address pin
DB2	97	I/O	1 bit of 8-bit bidirectional data bus
DB1	98	I/O	1 bit of 8-bit bidirectional data bus
DB0	99	I/O	1 bit of 8-bit bidirectional data bus
V <sub>DD2</sub>	100	P	supply voltage for high voltage generator; note 3

## Notes

1. This is the V<sub>LCD</sub> output pin, if V<sub>LCD</sub> is generated internally and has to be connected to V<sub>LCD1</sub>. If V<sub>LCD1</sub> is generated externally, V<sub>LCD2</sub> has to be left open or connected to ground.
2. This is the voltage used for the generation of LCD bias levels.
3. This is the supply for the high voltage generator. If V<sub>LCD</sub> is generated externally, connect V<sub>DD2</sub> to V<sub>SS</sub>.

LCD controller/driver

PCF2113x

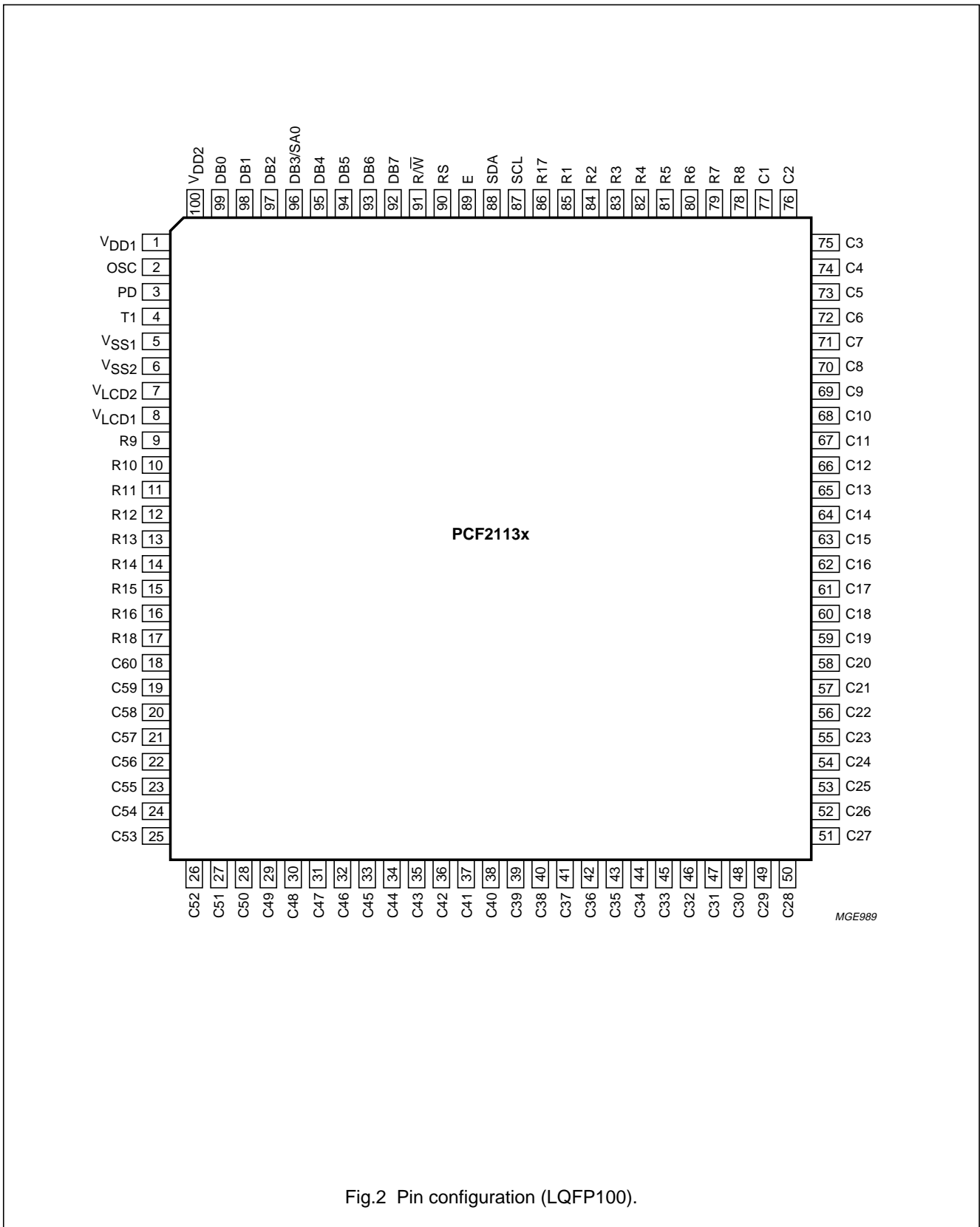

Fig.2 Pin configuration (LQFP100).

## LCD controller/driver

## PCF2113x

## 7 PIN FUNCTIONS

NAME	FUNCTION	DESCRIPTION
RS	register select	RS selects the register to be accessed for read and write when the device is controlled by the parallel interface. There is an internal pull-up on this pin. RS = logic 0 selects the instruction register for write and the Busy Flag and Address Counter for read. RS = logic 1 selects the data register for both read and write.
$\overline{R/W}$	read/write	$\overline{R/W}$ selects either the read ( $\overline{R/W}$ = logic 1) or write ( $\overline{R/W}$ = logic 0) operation when the device is controlled by the parallel interface. There is an internal pull-up on this pin.
E	data bus clock	The E pin is set HIGH to signal the start of a read or write operation when the device is controlled by the parallel interface. Data is clocked in or out of the chip on the negative edge of the clock. Note that this pin must be tied to logic 0 ( $V_{SS}$ ) when I <sup>2</sup> C-bus control is used.
DB7 to DB0	data bus	The parallel interface of the device. This bi-directional, 3-state data bus transfers data between the system controller and the PCF2113x. There is an internal pull-up on each of the data lines. DB7 to DB0 must be connected to $V_{DD}$ or left open circuit when I <sup>2</sup> C-bus control is used. Note that DB3 shares the same pin as SA0. In 4-bit operations only DB7 to DB4 are used, and DB3 to DB0 must be left open circuit. See note 1. DB7 may be used as the Busy Flag, signalling that internal operations are not yet completed.
C1 to C60	column driver outputs	These pins output the data for columns.
R1 to R18	row driver outputs	These pins output the row select waveforms to the display. R17 and R18 drive the icons.
$V_{LCD}$	LCD power supply	Positive power supply for the liquid crystal display. This may be generated on-chip or supplied externally.
OSC	oscillator	When the on-chip oscillator is used this pin must be connected to $V_{DD}$ . An external clock signal, if used, is input at this pin.
SCL	serial clock line	Input for the I <sup>2</sup> C-bus clock signal. SCL must be connected to $V_{SS}$ or $V_{DD}$ when the parallel interface is used.
SDA	serial data line	I/O for the I <sup>2</sup> C-bus data line. SDA must be connected to $V_{SS}$ or $V_{DD}$ when the parallel interface is used.
SA0	address pin	The hardware sub-address line is used to program the device sub-address for two different PCF2113xs on the same I <sup>2</sup> C bus. Note that SA0 shares the same pin as DB3.
T1	test pad	T1 must be connected to $V_{SS}$ and is not user accessible.
PD	power-down pad	PD selects chip power-down mode. For normal operation PD = logic 0.

**Note**

1. If the 4-bit interface is used without reading out from the PCF2113x (i.e.  $\overline{R/W}$  is set permanently to logic 0), the unused ports DB0 to DB3 can either be set to  $V_{SS}$  or  $V_{DD}$  instead of leaving them open.

## LCD controller/driver

## PCF2113x

**8 FUNCTIONAL DESCRIPTION** (see Fig.1)**8.1 LCD supply voltage generator**

The LCD supply voltage may be generated on-chip. The voltage generator is controlled by two internal 6-bit registers,  $V_A$  and  $V_B$ . The nominal LCD operating voltage at room temperature is given by the relationships:

$$V_{OP(nom)} = [(integer\ value\ of\ register) \times 0.08 + 1.9] V$$

**8.2 Programming ranges ( $T_{ref} = 27\ ^\circ C$ )**

Programmed value range: 1 to 63.  
Voltage range: 1.90 to 6.84 V.

**Values producing more than 6.5 V at operating temperature are not allowed.** Operation above this voltage may damage the device. When programming the operating voltage the  $V_{LCD}$  temperature coefficient must be taken into account.

**Values below 2.2 V are below the specified operating range of the chip and are therefore not allowed.**

Value 0 for  $V_A$  and  $V_B$  switches the generator off.

Usually register  $V_A$  is programmed with the voltage for character mode and register  $V_B$  with the voltage for icon mode.  $V_B$  must be programmed to FF in character mode and  $V_A$  must be programmed to 00 in icon mode.

When  $V_{LCD}$  is generated on-chip the  $V_{LCD}$  pins should be decoupled to  $V_{SS}$  with a suitable capacitor. The generated  $V_{LCD}$  is independent of  $V_{DD}$  and is temperature compensated. When the generator is switched off an external voltage may be supplied at connected pins  $V_{LCD1,2}$ .  $V_{LCD1,2}$  may be higher or lower than  $V_{DD}$  if external  $V_{LCD}$  is used. **If internally generated it must not be lower than  $V_{DD}$  and  $V_{DD} \leq 4V$ .**

**8.3 LCD bias voltage generator**

The intermediate bias voltages for the LCD display are also generated on-chip. This removes the need for an external resistive bias chain and significantly reduces the system current consumption. The optimum value of  $V_{LCD}$  depends on the multiplex rate, the LCD threshold voltage ( $V_{th}$ ) and the number of bias levels and is given by the relationships given in Tables 1 and 2. Using a 5-level bias scheme for 1 : 18 maximum rate allows  $V_{LCD} < 5 V$  for most LCD liquids.

**Table 1** Optimum/maximum values for  $V_{OP}$  (off pixels start darkening;  $V_{off} = V_{th}$ )

MUX RATE	NUMBER OF LEVELS	$V_{on}/V_{th}$	$V_{OP}/V_{th}$	$V_{OP}$ (typical; for $V_{th} = 1.4 V$ )
1 : 18	5	1.272	3.7	5.2 V
1 : 2	3	2.236	2.283	3.9 V

**Table 2** Minimum values for  $V_{OP}$  (on pixels clearly visible;  $V_{on} > V_{th}$ )

MUX RATE	NUMBER OF LEVELS	$V_{on}/V_{th}$	$V_{OP}/V_{th}$	$V_{OP}$ (typical; for $V_{th} = 1.4 V$ )
1 : 18	5	1.12	3.2	4.6 V
1 : 2	3	1.2	1.5	2.1 V

**8.4 Oscillator**

The on-chip oscillator provides the clock signal for the display system. No external components are required and the OSC pin must be connected to  $V_{DD}$ .

**8.5 External clock**

If an external clock is to be used this is input at the OSC pin. The resulting display frame frequency is given by

$$f_{frame} = \frac{f_{OSC}}{3072}$$

Only in the power-down state is the clock allowed to be stopped (OSC connected to  $V_{SS}$ ), otherwise the LCD is frozen in a DC state.

**8.6 Power-on reset**

The on-chip power-on reset block initializes the chip after power-on or power failure. This is a synchronous reset and requires 3 OSC cycles to be executed.



LCD controller/driver

PCF2113x

**8.7 Power-down mode**

The chip can be put into power-down mode where all static currents are switched off (no internal oscillator, no bias level generation, all LCD-outputs are internally connected to  $V_{SS}$ ) when PD = logic 1.

During power-down, the whole chip is reset and will restart with a clear display after power-down. Therefore, the whole chip has to be initialized after a power-down as after initial power-up.

The device should be put into 'display off' mode (instruction 'Display control') before putting the chip in power-down mode, otherwise the LCD output voltages are not defined.

**8.8 Registers**

The PCF2113x has two 8-bit registers, an Instruction Register (IR) and a Data Register (DR). The Register Select signal (RS) determines which register will be accessed. The instruction register stores instruction codes such as 'Display clear' and 'Cursor shift', and address information for the Display Data RAM (DDRAM) and Character Generator RAM (CGRAM). The instruction register can be written from but not read by the system controller. The data register temporarily stores data to be read from the DDRAM and CGRAM. When reading, data from the DDRAM or CGRAM corresponding to the address in the instruction register is written to the data register prior to being read by the 'Read data' instruction.

**8.9 Busy Flag**

The Busy Flag indicates the free/busy status of the PCF2113x. Logic 1 indicates that the chip is busy and further instructions will not be accepted. The Busy Flag is output to pin DB7 when RS = logic 0 and  $R/\bar{W}$  = logic 1. Instructions should only be written after checking that the Busy Flag is logic 0 or waiting for the required number of cycles.

**8.10 Address Counter (AC)**

The Address Counter assigns addresses to the DDRAM and CGRAM for reading and writing and is set by the instructions 'Set CGRAM address' and 'Set DDRAM address'. After a read/write operation the Address Counter is automatically incremented or decremented by 1. The Address Counter contents are output to the bus (DB6 to DB0) when RS = logic 0 and  $R/\bar{W}$  = logic 1.

**8.11 Display Data RAM (DDRAM)**

The DDRAM stores up to 80 characters of display data represented by 8-bit character codes. RAM locations which are not used for storing display data can be used as general purpose RAM. The basic DDRAM-to-display mapping is shown in Fig.3. With no display shift the characters represented by the codes in the first 24 RAM locations starting at address 00 in line 1 are displayed. Figures 4 and 5 show the display mapping for right and left shift respectively.

When data is written to or read from the DDRAM wrap-around occurs from the end of one line to the start of the next line. When the display is shifted each line wraps around within itself, independently of the others. Thus all lines are shifted and wrapped around together. The address ranges and wrap-around operations for the various modes are shown in Table 3.

**Table 3** Address space and wrap-around operation

MODE	1 × 24	2 × 12
address space	00 to 4F	00 to 27; 40 to 67
read/write wrap-around (moves to next line)	4F to 00	27 to 40; 67 to 00
display shift wrap-around (stays within line)	4F to 00	27 to 00; 67 to 40

**8.12 Character Generator ROM (CGROM)**

The Character Generator ROM (CGROM) generates 240 character patterns in 5 × 8 dot format from 8-bit character codes. Figures 7, 8 and 9 show the character sets that are currently implemented.

**8.13 Character Generator RAM (CGRAM)**

Up to 16 user defined characters may be stored in the Character Generator RAM (CGRAM). Some CGRAM characters (see Fig.17) are also used to drive icons (6 if icons blink and both icon rows are used in application; 3 if no blink but both icon rows are used in application; 0 if no icons are driven by the icon rows). The CGROM and CGRAM use a common address space, of which the first column is reserved for the CGRAM (see Fig.7). Figure 10 shows the addressing principle for the CGRAM.

LCD controller/driver

PCF2113x

8.14 Cursor control circuit

The cursor control circuit generates the cursor (underline and/or cursor blink as shown in Fig.6) at the DDRAM address contained in the Address Counter. When the Address Counter contains the CGRAM address the cursor will be inhibited.

8.15 Timing generator

The timing generator produces the various signals required to drive the internal circuitry. Internal chip operation is not disturbed by operations on the data buses.

8.16 LCD row and column drivers

The PCF2113x contains 18 row and 60 column drivers, which connect the appropriate LCD bias voltages in sequence to the display in accordance with the data to be displayed. R17 and R18 drive the icon rows.

The bias voltages and the timing are selected automatically when the number of lines in the display is selected. Figures 11, 12 and 13 show typical waveforms. Unused outputs should be left unconnected.

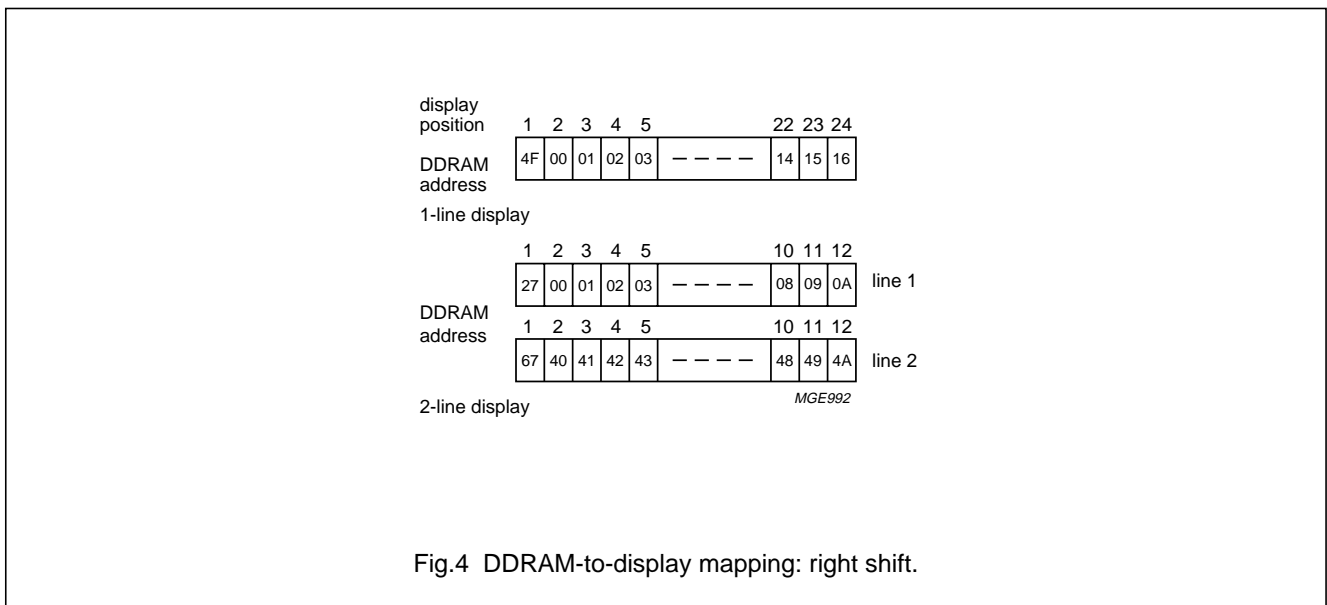
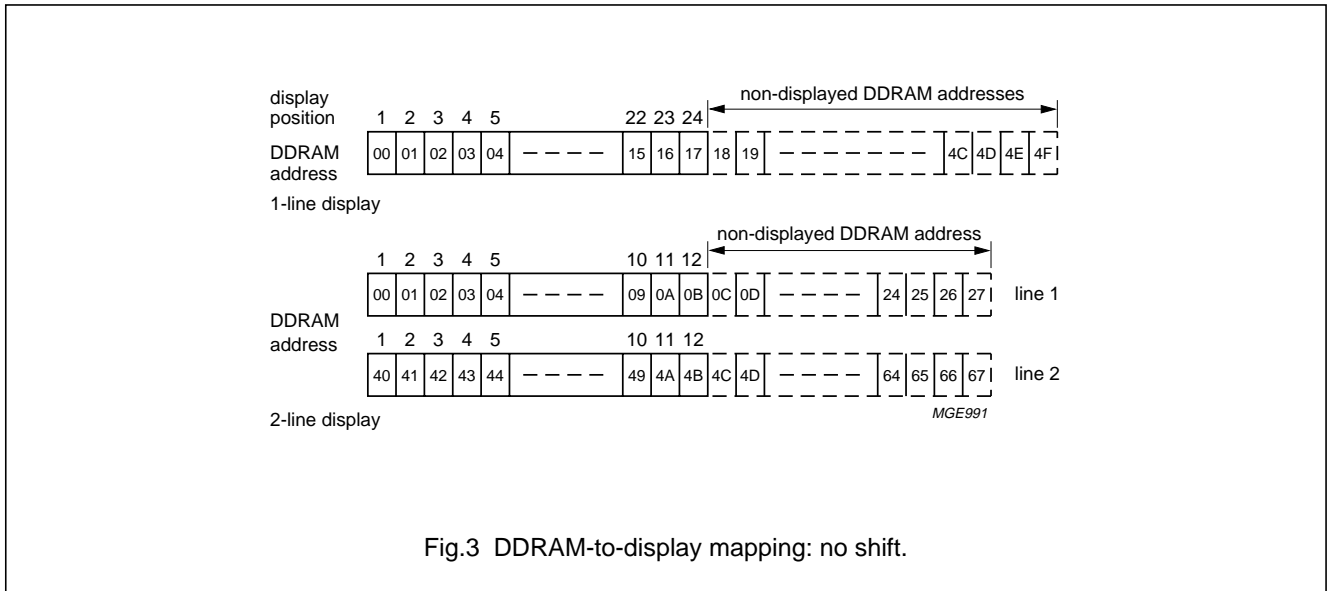

LCD controller/driver

PCF2113x

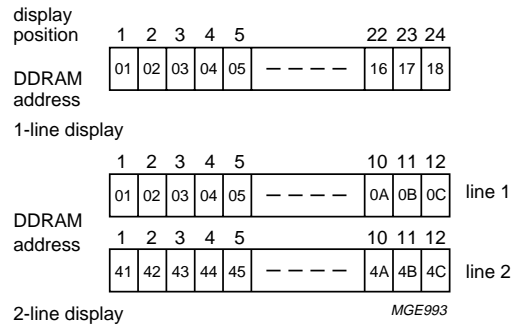

Fig.5 DDRAM-to-display mapping: left shift.

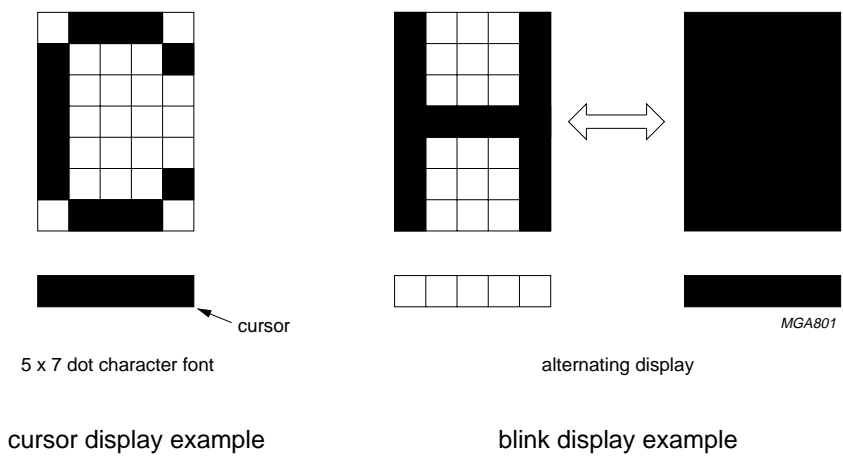

Fig.6 Cursor and blink display examples.

LCD controller/driver

PCF2113x

upper 4 bits lower 4 bits	0000	0001	0010	0011	0100	0101	0110	0111	1000	1001	1010	1011	1100	1101	1110	1111
xxxx 0000	1	A	B	C	D	E	F	G	H	I	J	K	L	M	N	O
xxxx 0001	2	P	Q	R	S	T	U	V	W	X	Y	Z	[	\	]	^
xxxx 0010	3	_	`	a	b	c	d	e	f	g	h	i	j	k	l	m
xxxx 0011	4	n	o	p	q	r	s	t	u	v	w	x	y	z	{	
xxxx 0100	5	~														
xxxx 0101	6															
xxxx 0110	7															
xxxx 0111	8															
xxxx 1000	9															
xxxx 1001	10															
xxxx 1010	11															
xxxx 1011	12															
xxxx 1100	13															
xxxx 1101	14															
xxxx 1110	15															
xxxx 1111	16															

MGE994

Fig.7 Character set 'A' in CGROM: PCF2113A.

LCD controller/driver

PCF2113x

upper 4 bits \ lower 4 bits	0000	0001	0010	0011	0100	0101	0110	0111	1000	1001	1010	1011	1100	1101	1110	1111
xxxx 0000	1	0	1	2	3	4	5	6	7	8	9	:	;	<	=	~
xxxx 0001	2	;	1	2	3	4	5	6	7	8	9	:	;	<	=	~
xxxx 0010	3	<	2	3	4	5	6	7	8	9	:	;	<	=	~	0
xxxx 0011	4	<	3	4	5	6	7	8	9	:	;	<	=	~	1	2
xxxx 0100	5	0	1	2	3	4	5	6	7	8	9	:	;	<	=	~
xxxx 0101	6	1	2	3	4	5	6	7	8	9	:	;	<	=	~	0
xxxx 0110	7	2	3	4	5	6	7	8	9	:	;	<	=	~	1	2
xxxx 0111	8	3	4	5	6	7	8	9	:	;	<	=	~	0	1	2
xxxx 1000	9	4	5	6	7	8	9	:	;	<	=	~	0	1	2	3
xxxx 1001	10	5	6	7	8	9	:	;	<	=	~	0	1	2	3	4
xxxx 1010	11	6	7	8	9	:	;	<	=	~	0	1	2	3	4	5
xxxx 1011	12	7	8	9	:	;	<	=	~	0	1	2	3	4	5	6
xxxx 1100	13	8	9	:	;	<	=	~	0	1	2	3	4	5	6	7
xxxx 1101	14	9	:	;	<	=	~	0	1	2	3	4	5	6	7	8
xxxx 1110	15	:	;	<	=	~	0	1	2	3	4	5	6	7	8	9
xxxx 1111	16	;	<	=	~	0	1	2	3	4	5	6	7	8	9	:

MGD688

Fig.8 Character set 'D' in CGROM: PCF2113D.

LCD controller/driver

PCF2113x

lower 4 bits \ upper 4 bits	0000	0001	0010	0011	0100	0101	0110	0111	1000	1001	1010	1011	1100	1101	1110	1111
xxxx 0000	1	B	P	O	S	W	Q	Q		0	I	P	C	P		
xxxx 0001	2	D	N	B	S	W	W	E		!	!	A	D	a	a	
xxxx 0010	3	E	I	l	p	b	p	\$	#	"	2	B	R	b	r	
xxxx 0011	4	K	S	S	S	B	A	¥	¥	#	3	C	S	c	s	
xxxx 0100	5	a	l	t	λ	b	(	e	a	D	4	D	T	d	t	
xxxx 0101	6	N	4	e	e	w	c	)	e	D	%	5	E	U	e	U
xxxx 0110	7	W	e	B	o	n	*	i	O	n	K	6	F	U	f	U
xxxx 0111	8	Q	I	D	o	v	*	+	l	Y	'	7	B	W	B	W
xxxx 1000	9	Q	I	ó	n	o	÷	÷	ó	Σ	(	B	H	K	h	X
xxxx 1001	10	Q	I	U	U	á	á	á	á	á	)	9	I	Y	i	Y
xxxx 1010	11	Q	I	á	á	á	á	á	á	á	*	*	J	Z	j	Z
xxxx 1011	12	Q	I	ö	k	B	O	O	O		+	;	K	A	k	A
xxxx 1100	13	z	z	\	z	z	z	z	z	z	,	<	L	O	l	ö
xxxx 1101	14	z	z	z	z	z	z	z	z	z	-	=	M	N	n	ñ
xxxx 1110	15	z	z	z	z	z	z	z	z	z	.	>	N	O	n	ü
xxxx 1111	16	z	z	z	z	z	z	z	z	z	/	?	O	S	o	á

MGD689

Fig.9 Character set 'E' in CGROM: PCF2113E.

LCD controller/driver

PCF2113x

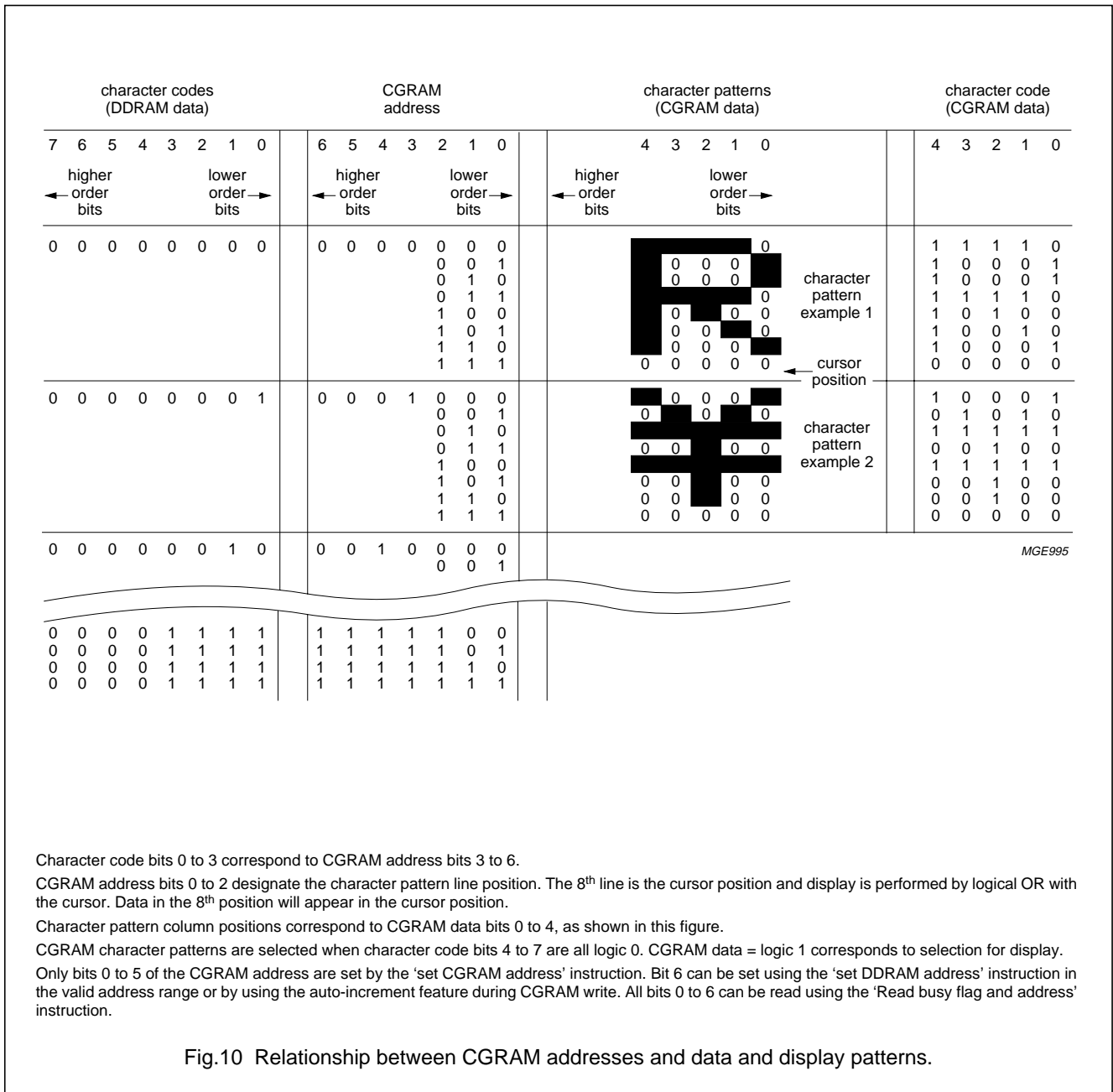

Character code bits 0 to 3 correspond to CGRAM address bits 3 to 6.  
 CGRAM address bits 0 to 2 designate the character pattern line position. The 8<sup>th</sup> line is the cursor position and display is performed by logical OR with the cursor. Data in the 8<sup>th</sup> position will appear in the cursor position.  
 Character pattern column positions correspond to CGRAM data bits 0 to 4, as shown in this figure.  
 CGRAM character patterns are selected when character code bits 4 to 7 are all logic 0. CGRAM data = logic 1 corresponds to selection for display.  
 Only bits 0 to 5 of the CGRAM address are set by the 'set CGRAM address' instruction. Bit 6 can be set using the 'set DDRAM address' instruction in the valid address range or by using the auto-increment feature during CGRAM write. All bits 0 to 6 can be read using the 'Read busy flag and address' instruction.

Fig.10 Relationship between CGRAM addresses and data and display patterns.

LCD controller/driver

PCF2113x

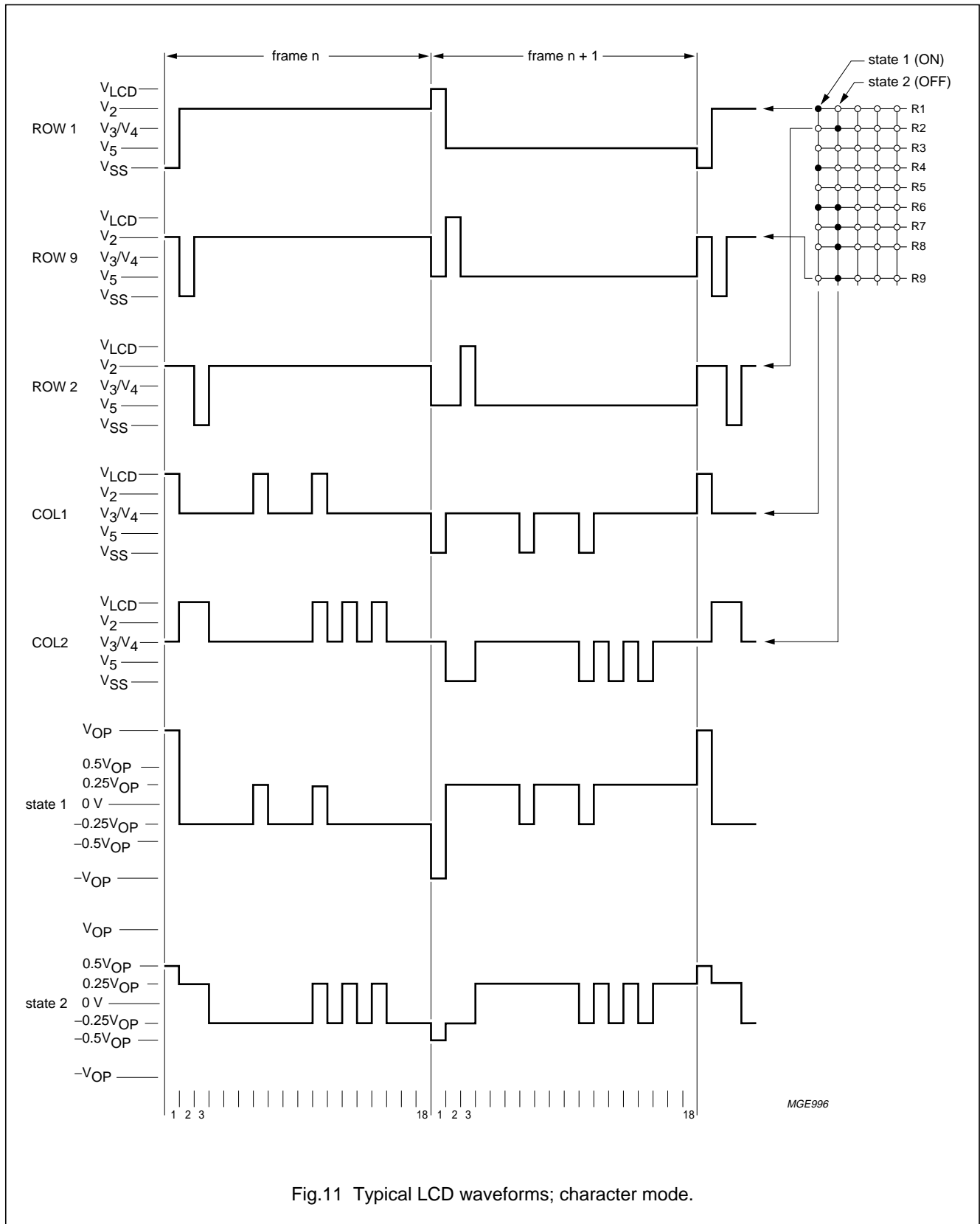

Fig.11 Typical LCD waveforms; character mode.



LCD controller/driver

PCF2113x

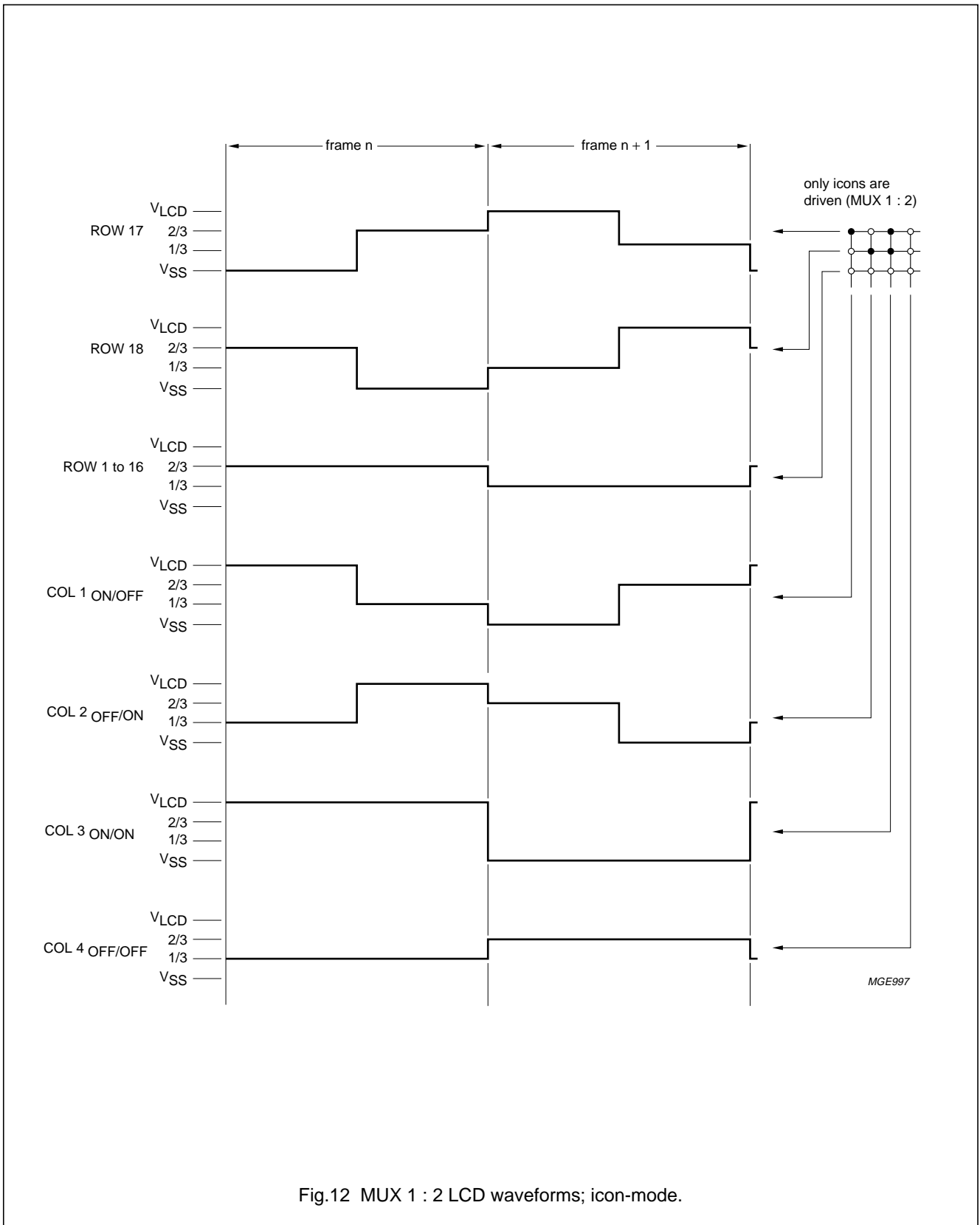

Fig.12 MUX 1 : 2 LCD waveforms; icon-mode.

LCD controller/driver

PCF2113x

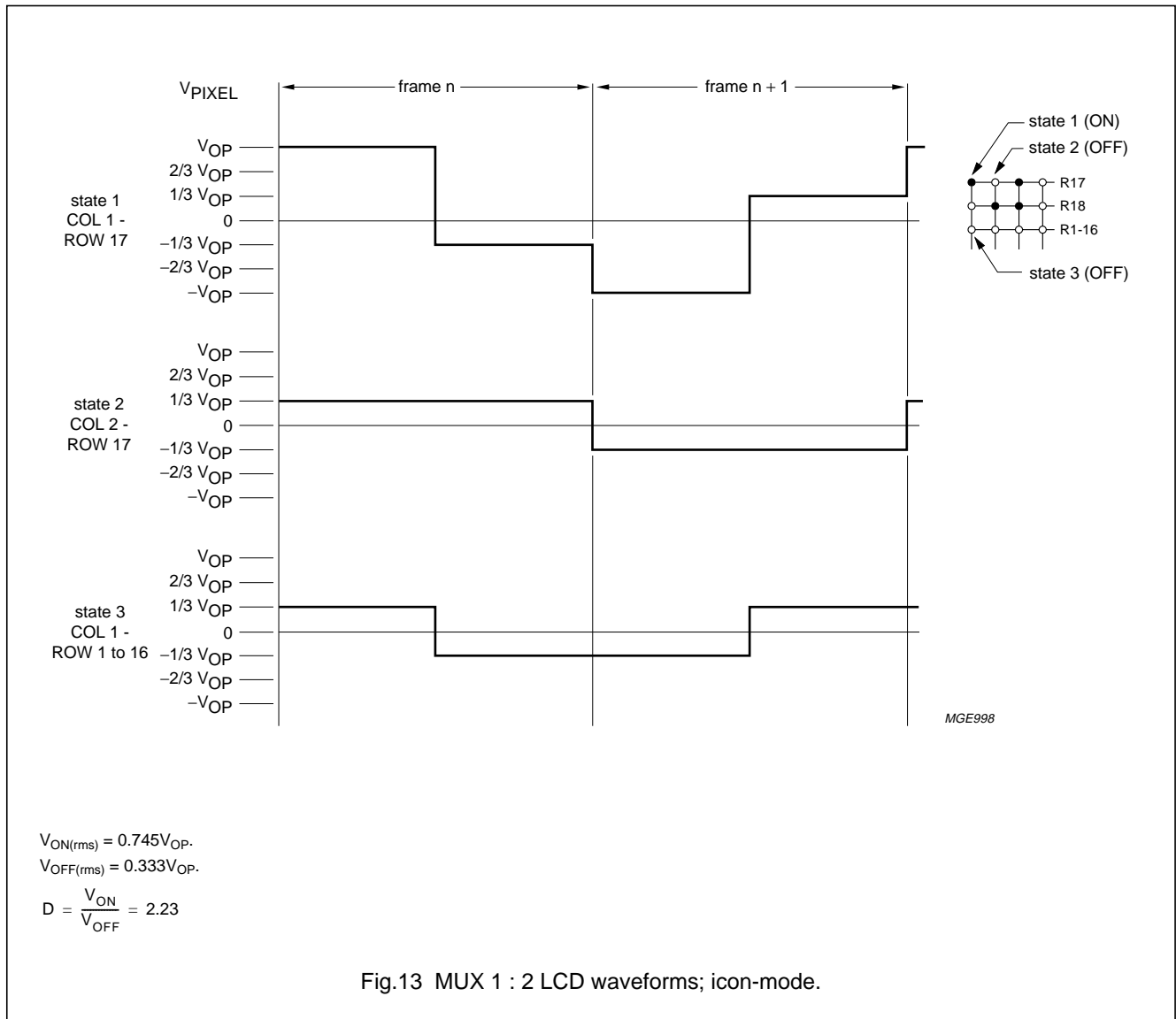

Fig.13 MUX 1 : 2 LCD waveforms; icon-mode.

## LCD controller/driver

## PCF2113x

**8.17 Reset function**

The PCF2113x automatically initializes (resets) when power is turned on. The chip executes a reset sequence, requiring 165 OSC cycles. After the reset the chip's functions are in the states shown in Table 4.

**Table 4** State after reset

STEP	FUNCTION	RESET STATE (BIT/REGISTER)	RESET STATE (DESCRIPTION)
1	clear display		
2	entry mode set	I/D = 1	+1 (increment)
		S = 0	no shift
3	display control	D = 0	display off
		C = 0	cursor off
		B = 0	cursor character blink off
4	function set	DL = 1	8-bit interface
		M = 0	1-line display
		H = 0	normal instruction set
5	default address pointer to DDRAM; the Busy Flag (BF) indicates the busy state (BF = logic 1) until initialization ends; the busy state lasts 2 ms; the chip may also be initialized by software; see Tables 17 and 18		
6	icon control	IM, IB = 00	icons/icon blink disabled
7	display/screen configuration	L, P, Q = 000	default configurations
8	V <sub>LCD</sub> temperature coefficient	TC1, TC2 = 00	default temperature coefficient
9	set V <sub>LCD</sub>	V <sub>A</sub> , V <sub>B</sub> = 0	V <sub>LCD</sub> generator off
10	I <sup>2</sup> C-bus interface reset		

LCD controller/driver

PCF2113x

**9 INSTRUCTIONS**

Only two PCF2113x registers, the Instruction Register (IR) and the Data Register (DR) can be directly controlled by the microcontroller. Before internal operation, control information is stored temporarily in these registers, to allow interface to various types of microcontrollers which operate at different speeds or to allow interface to peripheral control ICs.

The format for instructions when I<sup>2</sup>C-bus control is used is shown in Table 5. The PCF2113x operation is controlled by the instructions shown in Table 6, which also gives execution times in clock cycles. Details are explained in subsequent sections.

Instructions are of 4 types, those that:

1. Designate PCF2113x functions such as display format, data length, etc.
2. Set internal RAM addresses
3. Perform data transfer with internal RAM
4. Others.

In normal use, category 3 instructions are used most frequently. However, automatic incrementing by 1 (or decrementing by 1) of internal RAM addresses after each data write lessens the microcontroller program load. The display shift in particular can be performed concurrently with display data write, enabling the designer to develop systems in minimum time with maximum programming efficiency.

During internal operation, no instruction other than the 'Read busy flag and address' instruction will be executed. Because the Busy Flag is set to logic 1 while an instruction is being executed, check to make sure it is on logic 0 before sending the next instruction or wait for the maximum instruction execution time, as given in Table 6. An instruction sent while the Busy Flag is logic 1 will not be executed.

**Table 5** Instruction format for I<sup>2</sup>C-bus instructions

CONTROL BYTE <sup>(1)</sup>								COMMAND BYTE							
Co	RS	0	0	0	0	0	0	DB7	DB6	DB5	DB4	DB3	DB2	DB1	DB0

**Note**

1.  $\overline{R/W}$  is set together with the slave address.

## LCD controller/driver

## PCF2113X

Table 6 Instructions

INSTRUCTION	RS	R/W	DB7	DB6	DB5	DB4	DB3	DB2	DB1	DB0	DESCRIPTION	REQUIRED CLOCK CYCLES
<b>H = 0 or 1</b>												
NOP	0	0	0	0	0	0	0	0	0	0	no operation	3
Function set	0	0	0	0	1	DL	0	M	0	H	sets interface Data Length (DL) and number of display lines (M); extended instruction set control (H)	3
Read busy flag and address	0	1	BF	A <sub>C</sub>						reads the Busy Flag (BF) indicating internal operating is being performed and reads Address Counter contents		0
Read data	1	1	read data						reads data from CGRAM or DDRAM		3	
Write data	1	0	write data						writes data from CGRAM or DDRAM		3	
<b>H = 0</b>												
Clear display	0	0	0	0	0	0	0	0	0	1	clears entire display and sets DDRAM address 0 in Address Counter	165
Return home	0	0	0	0	0	0	0	0	1	0	sets DDRAM address 0 in Address Counter; also returns shifted display to original position; DDRAM contents remain unchanged	3
Entry mode set	0	0	0	0	0	0	0	1	I/D	S	sets cursor move direction and specifies shift of display; these operations are performed during data write and read	3
Display control	0	0	0	0	0	0	1	D	C	B	sets entire display on/off (D), cursor on/off (C) and blink of cursor position character (B); D = 0 (display off) puts chip into power-down mode	3
Cursor/display shift	0	0	0	0	0	1	S/C	R/L	0	0	moves cursor and shifts display without changing DDRAM contents	3
Set CGRAM address	0	0	0	1	A <sub>CG</sub>						sets CGRAM address; bit 6 is to be set by the instruction 'Set DDRAM address'; look at the description of the instructions	3
Set DDRAM address	0	0	1	A <sub>DD</sub>						sets DDRAM address		3

## LCD controller/driver

PCF2113X

INSTRUCTION	RS	R/W	DB7	DB6	DB5	DB4	DB3	DB2	DB1	DB0	DESCRIPTION	REQUIRED CLOCK CYCLES
<b>H = 1</b>												
Reserved	0	0	0	0	0	0	0	0	0	1	do not use	–
Screen configuration	0	0	0	0	0	0	0	0	1	L	set screen configuration	3
Display configuration	0	0	0	0	0	0	0	1	P	Q	set display configuration	3
Icon control	0	0	0	0	0	0	1	IM	IB	0	set icon mode (IM), icon blink (IB)	3
Temperature control	0	0	0	0	0	1	0	0	TC1	TC2	set temperature coefficient (TCx)	3
Reserved	0	0	0	1	X <sup>(1)</sup>	X <sup>(1)</sup>	X <sup>(1)</sup>	X <sup>(1)</sup>	X <sup>(1)</sup>	X <sup>(1)</sup>	do not use	–
Set V <sub>LCD</sub>	0	0	1	V	voltage					store V <sub>LCD</sub> in register V <sub>A</sub> or V <sub>B</sub> (V)		3

**Note**

1. X = don't care.

## LCD controller/driver

## PCF2113x

**Table 7** Explanations of symbols used in Table 6

BIT	0	1
I/D	decrement	increment
S	display freeze	display shift
D	display off	display on
C	cursor off	cursor on
B	cursor character blink off: character at cursor position does not blink	cursor character blink on: character at cursor position blinks
S/C	cursor move	display shift
R/L	left shift	right shift
DL	4 bits	8 bits
H	use basic instruction set	use extended instruction set
L (no impact, if M = 1)	left/right screen: standard connection (as in PCF2114); 1st 12 characters of 24: columns are from 1 to 60 2nd 12 characters of 24: columns are from 1 to 60	left/right screen: mirrored connection (as in PCF2116); 1st 12 characters of 24: columns are from 1 to 60 2nd 12 characters of 24: columns are from 60 to 1
P	column data: left to right (as in PCF2116); column data is displayed from 1 to 60	column data: right to left; column data is displayed from 60 to 1
Q	row data: top to bottom (as in PCF2116); row data is displayed from 1 to 16 and icon row data is in 17 and 18	row data: bottom to top; row data is displayed from 16 to 1 and icon row data is in 18 and 17
IM	character mode; full display	icon mode; only icons displayed
IB	icon blink disabled	icon blink enabled
V	set $V_A$	set $V_B$
M	1-line by 24 display	2-line by 12 display
C <sub>0</sub>	last control byte; see Table 5	another control byte follows after data/instruction

**Table 8** Explanation of TC1 and TC2 used in Table 6

TC1	TC2	DESCRIPTION
0	0	$V_{LCD}$ temperature coefficient 0
1	0	$V_{LCD}$ temperature coefficient 1
0	1	$V_{LCD}$ temperature coefficient 2
1	1	$V_{LCD}$ temperature coefficient 3; for ranges for TC see Chapter 15

LCD controller/driver

PCF2113x

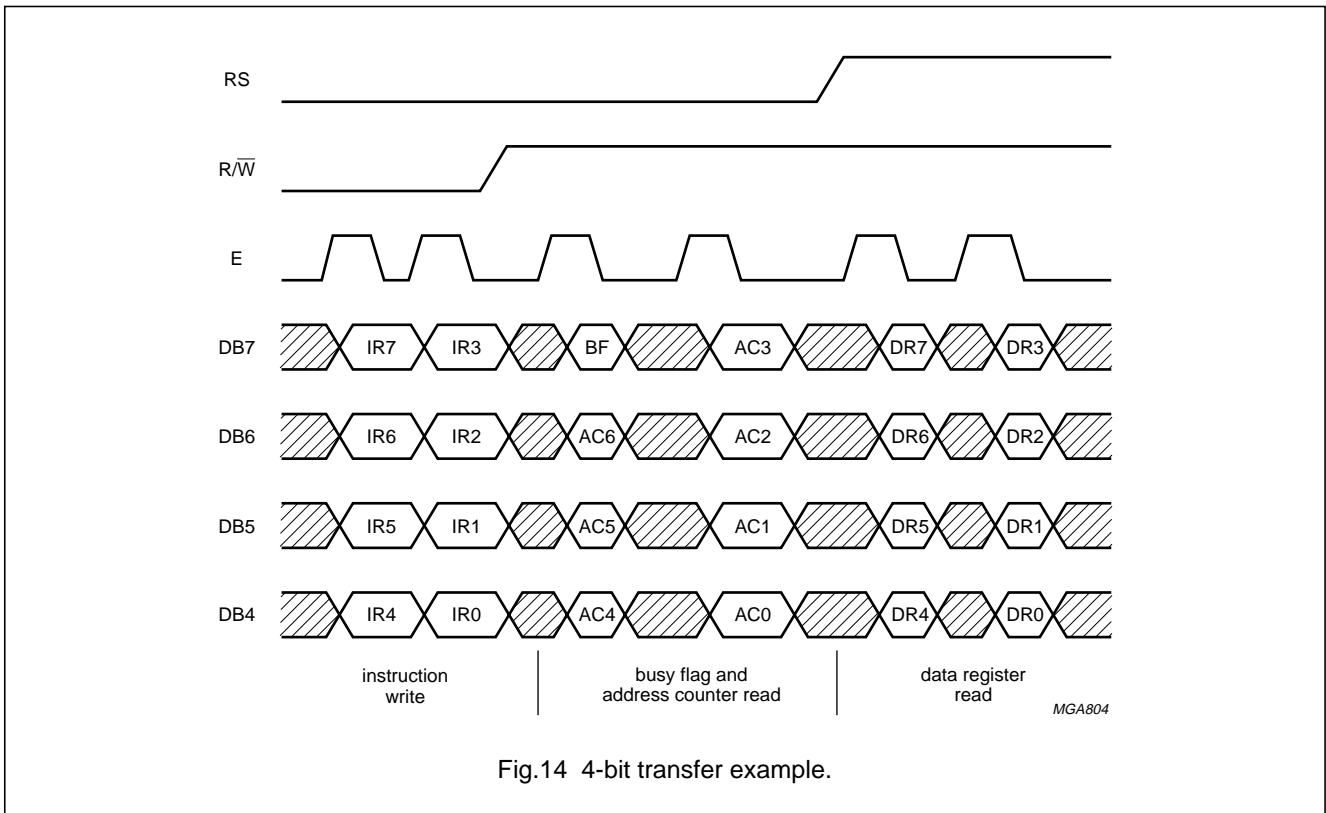
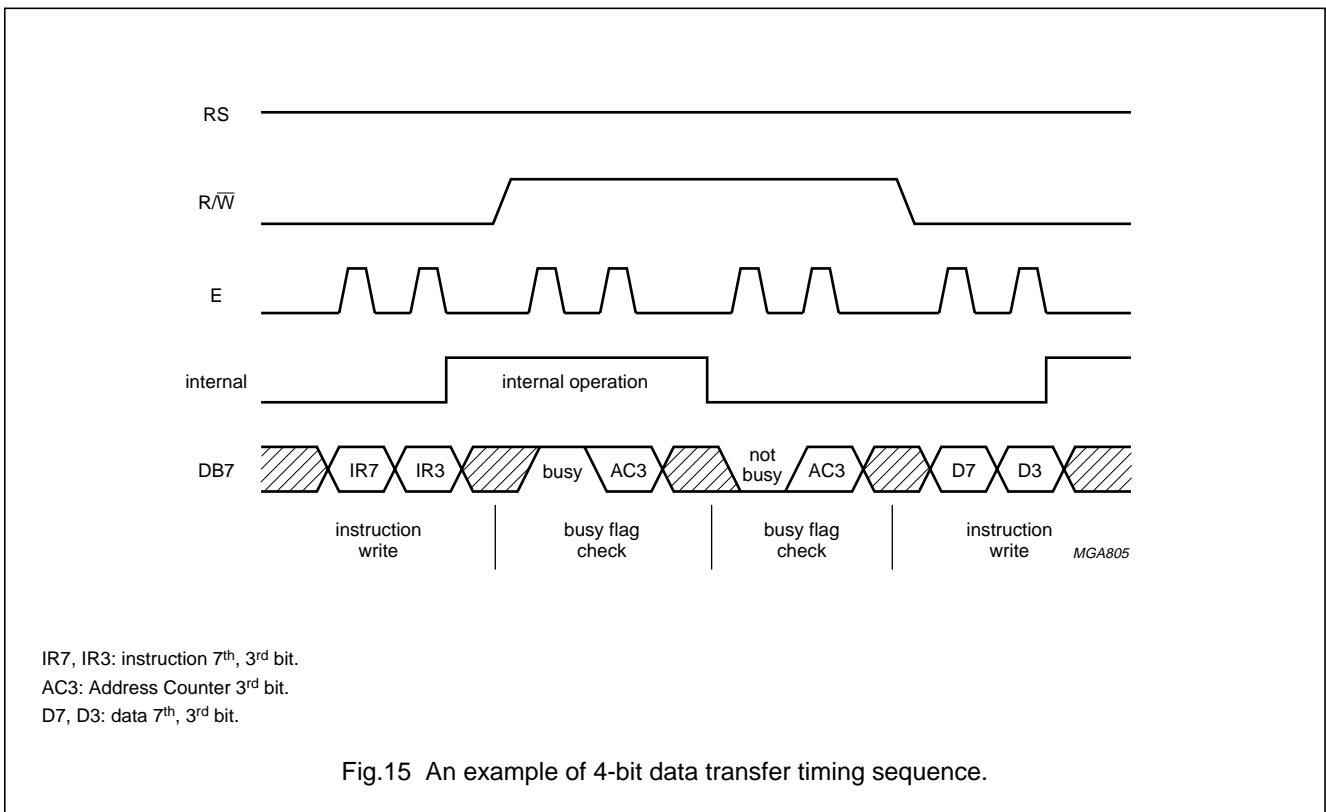

Fig.14 4-bit transfer example.



IR7, IR3: instruction 7<sup>th</sup>, 3<sup>rd</sup> bit.  
 AC3: Address Counter 3<sup>rd</sup> bit.  
 D7, D3: data 7<sup>th</sup>, 3<sup>rd</sup> bit.

Fig.15 An example of 4-bit data transfer timing sequence.



LCD controller/driver

PCF2113x

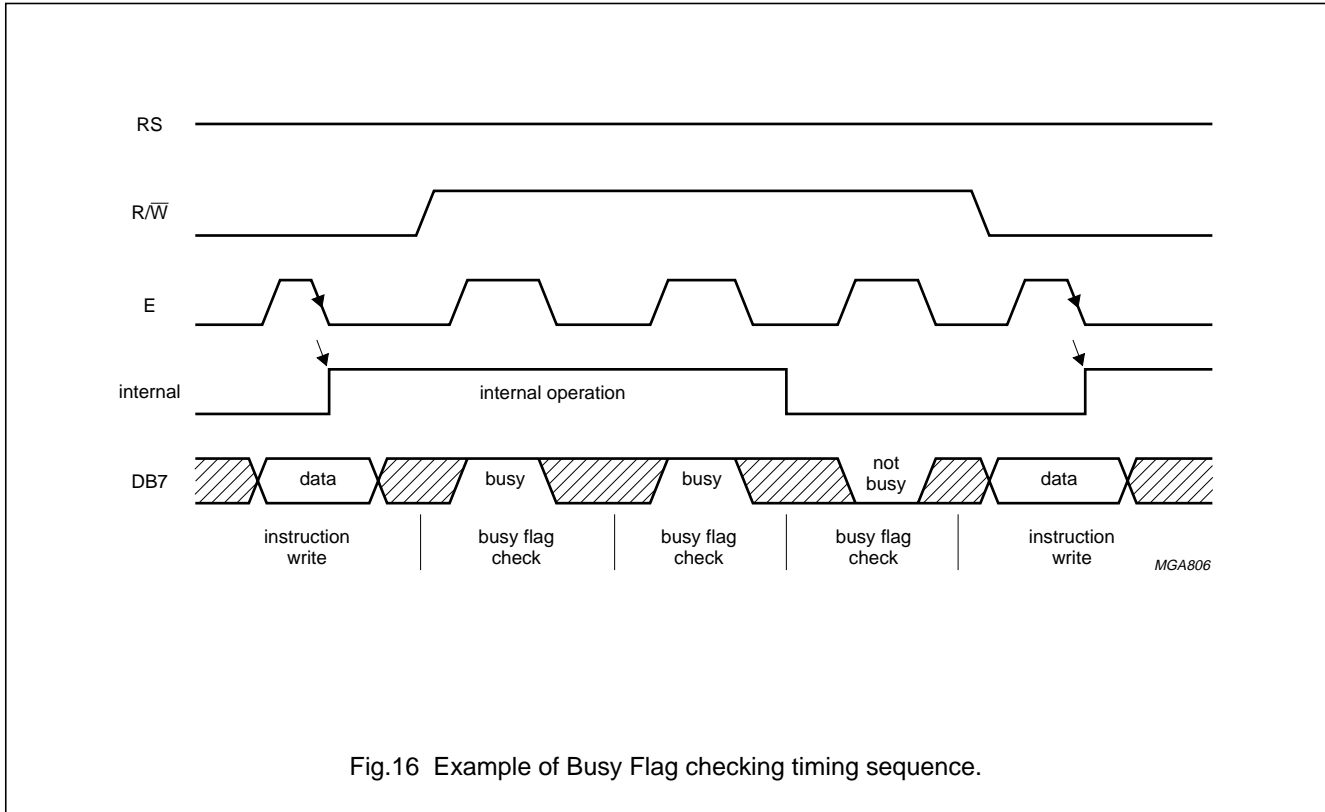

Fig.16 Example of Busy Flag checking timing sequence.

9.1 Clear display

'Clear display' writes character code 20 (hexadecimal) into all DDRAM addresses (the character pattern for character code 20 must be blank pattern), sets the DDRAM Address Counter to logic 0 and returns display to its original position if it was shifted. Thus, the display disappears and the cursor or blink position goes to the left edge of the display. Sets entry mode I/D = logic 1 (increment mode). S of entry mode does not change.

The instruction 'Clear display' requires extra execution time. This may be allowed by checking the Busy Flag (BF) or by waiting until the 165 clock cycles have elapsed. The latter must be applied where no read-back options are foreseen, as in some Chip-On-Glass (COG) applications.

9.2 Return home

'Return home' sets the DDRAM Address Counter to logic 0 and returns display to its original position if it was shifted. DDRAM contents do not change. The cursor or blink position goes to the left of the first display line. I/D and S of entry mode do not change.

9.3 Entry mode set

9.3.1 I/D

When I/D = logic 1 (0) the DDRAM or CGRAM address increments (decrements) by 1 when data is written into or read from the DDRAM or CGRAM. The cursor or blink position moves to the right when incremented and to the left when decremented. The cursor underline and cursor character blink are inhibited when the CGRAM is accessed.

9.3.2 S

When S = logic 1, the entire display shifts either to the right (I/D = logic 0) or to the left (I/D = logic 1) during a DDRAM write. Thus it looks as if the cursor stands still and the display moves. The display does not shift when reading from the DDRAM, or when writing into or reading out of the CGRAM. When S = logic 0 the display does not shift.

## LCD controller/driver

## PCF2113x

**9.4 Display control (and partial power-down mode)****9.4.1 D**

The display is on when D = logic 1 and off when D = logic 0. Display data in the DDRAM are not affected and can be displayed immediately by setting D to logic 1.

When the display is off (D = logic 0) the chip is in partial power-down mode:

- The LCD-outputs are connected to  $V_{SS}$
- The LCD generator and bias generator are turned off.

3 OSC cycles are required after sending the 'Display off' instruction to ensure all outputs are at  $V_{SS}$ , afterwards OSC can be stopped. If the oscillator is running during partial power-down mode ('Display off') the chip can still execute instructions. Even lower current consumption is obtained by inhibiting the oscillator (OSC =  $V_{SS}$ ).

To ensure  $I_{DD} < 1 \mu A$  the parallel bus pins DB7 to DB0 should be connected to  $V_{DD}$ ; RS,  $R/\overline{W}$ , to  $V_{DD}$  or left open and PD to  $V_{DD}$ . Recovery from power-down mode: PD back to logic 0, if necessary OSC back to  $V_{DD}$ , send a 'Display control' instruction with D = logic 1.

**9.4.2 C**

The cursor is displayed when C = logic 1 and inhibited when C = logic 0. Even if the cursor disappears, the display functions I/D, etc. remain in operation during display data write. The cursor is displayed using 5 dots in the 8th line (see Fig.6).

**9.4.3 B**

The character indicated by the cursor blinks when B = logic 1. The cursor character blink is displayed by switching between display characters and all dots on with

a period of approximately 1 s, with  $f_{BLINK} = \frac{f_{OSC}}{52\ 224}$

The cursor underline and the cursor character blink can be set to display simultaneously.

**9.5 Cursor/display shift**

'Cursor/display shift' moves the cursor position or the display to the right or left without writing or reading display data. This function is used to correct a character or move the cursor through the display. In 2-line displays, the cursor moves to the next line when it passes the last position (40) of the line. When the displayed data is shifted repeatedly all lines shift at the same time; displayed characters do not shift into the next line.

The Address Counter (AC) content does not change if the only action performed is shift display, but increments or decrements with the 'cursor shift'.

**9.6 Function set****9.6.1 DL (PARALLEL MODE ONLY)**

Sets interface data width. Data is sent or received in bytes (DB7 to DB0) when DL = logic 1 or in two nibbles (DB7 to DB4) when DL = logic 0. When 4-bit width is selected, data is transmitted in two cycles using the parallel bus. In a 4-bit application DB3 to DB0 should be left open (internal pull-ups). Hence in the first 'Function set' instruction after power-on N and H are set to logic 1. A second 'Function set' must then be sent (2 nibbles) to set N and H to their required values.

'Function set' from I<sup>2</sup>C-interface sets the DL bit to logic 1.

**9.6.2 M**

Chooses either 1-line by 24 display (M = 0) or 2-line by 12 display (M = 1).

**9.6.3 H**

When H = logic 0 the chip can be programmed via the standard 11 instruction codes used in the PCF2116 and other LCD controllers.

When H = logic 1 the extended range of instructions will be used. These are mainly for controlling the display configuration and the icons.

**9.7 Set CGRAM address**

'Set CGRAM address' sets bits 5 to 0 of the CGRAM address ( $A_{CG}$  in Table 6) into the Address Counter (binary A[5] to A[0]).

Data can then be written to or read from the CGRAM.

**Attention:** the CGRAM address uses the same address register as the DDRAM address and consists of 7 bits (binary A[6] to A[0]). With the 'Set CGRAM address' instruction, only bits 5 down to 0 are set. Bit 6 can be set using the 'Set DDRAM address' instruction first, or by using the auto-increment feature during CGRAM write. All of bits 6 to 0 can be read using the 'Read busy flag and address' instruction.

When writing to the lower part of the CGRAM, make sure that bit 6 of the address is not set (e.g. by an earlier DDRAM write or read action).

## LCD controller/driver

## PCF2113x

**9.8 Set DDRAM address**

'Set DDRAM address' sets the DDRAM address ( $A_{DD}$  in Table 6) into the Address Counter (binary A[6] to A[0]). Data can then be written to or read from the DDRAM.

**9.9 Read busy flag and address**

'Read busy flag and address' reads the Busy Flag (BF) and Address Counter (AC). BF = logic 1 indicates that an internal operation is in progress. The next instruction will not be executed until BF = logic 0, so BF should be checked before sending another instruction.

At the same time, the value of the Address Counter expressed in binary A[6] to A[0] is read out. The Address Counter is used by both CGRAM and DDRAM, and its value is determined by the previous instruction.

**9.10 Write data to CGRAM or DDRAM**

'Write data' writes binary 8-bit data D[7] to D[0] to the CGRAM or the DDRAM.

Whether the CGRAM or DDRAM is to be written into is determined by the previous 'Set CGRAM address' or 'Set DDRAM address' instruction. After writing, the address automatically increments or decrements by 1, in accordance with the entry mode. Only bits D[4] to D[0] of CGRAM data are valid, bits D[7] to D[5] are 'don't care'.

**9.11 Read data from CGRAM or DDRAM**

'Read data' reads binary 8-bit data D[7] to D[0] from the CGRAM or DDRAM.

The most recent 'Set address' instruction determines whether the CGRAM or DDRAM is to be read.

The 'Read data' instruction gates the content of the Data Register (DR) to the bus while E is high. After E goes low again, internal operation increments (or decrements) the AC and stores RAM data corresponding to the new AC into the DR.

Note: the only three instructions that update the Data Register (DR) are:

- 'Set CGRAM address'
- 'Set DDRAM address'
- 'Read data' from CGRAM or DDRAM.

Other instructions (e.g. 'Write data', 'Cursor/display shift', 'Clear display', 'Return home') do not modify the data register content.

**10 EXTENDED FUNCTION SET INSTRUCTIONS AND FEATURES****10.1 New instructions**

H = logic 1 sets the chip into alternate instruction set mode.

**10.2 Icon control**

The PCF2113x can drive up to 120 icons. See Fig.17 for CGRAM to icon mapping.

**10.3 IM**

When IM = logic 0 the chip is in character mode. In character mode characters and icons are driven (MUX 1 : 18). The  $V_{LCD}$  generator, if used, produces the  $V_{LCD}$  voltage programmed in register  $V_A$ .

When IM = logic 1 the chip is in icon mode. In icon mode only the icons are driven (MUX 1 : 2) and the  $V_{LCD}$  voltage generator, if used, produces the  $V_{LCD}$  voltage programmed in register  $V_B$ .

**Remark: If internally generated  $V_{LCD}$  must not be lower than  $V_{DD}$  ( $V_{DD} \leq 4 V$ )**

**10.4 IB**

Icon blink control is independent of the cursor/character blink function.

When IB = logic 0 icon blink is disabled. Icon data is stored in CGRAM character 0 to 2 ( $3 \times 8 \times 5 = 120$  bits for 120 icons).

When IB = logic 1 icon blink is enabled. In this case each icon is controlled by two bits. Blink consists of two half phases (corresponding to the cursor on and off phases called even and odd phases hereafter).

Icon states for the even phase are stored in CGRAM characters 0 to 2 ( $3 \times 8 \times 5 = 120$  bits for 120 icons). These bits also define icon state when icon blink is not used.

Icon states for the odd phase are stored in CGRAM character 4 to 6 (another 120 bits for the 120 icons). When icon blink is disabled CGRAM characters 4 to 6 may be used as normal CGRAM characters.

LCD controller/driver

PCF2113x

**Table 9** Blink effect for icons and cursor character blink

PARAMETER	EVEN PHASE	ODD PHASE
Cursor underline	on	off
Cursor character blink	block (all on)	normal (display character)
Icons	state 1: CGRAM character 0 to 2	state 2: CGRAM character 4 to 6

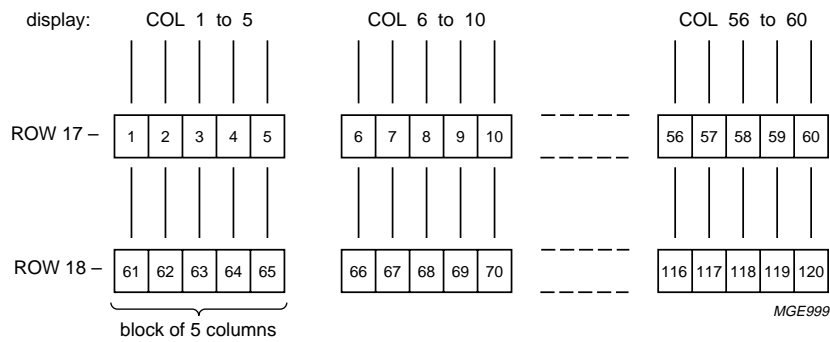

icon no.	phase	ROW/COL	character codes								CGRAM address				CGRAM data				icon view				
			7	6	5	4	3	2	1	0	6	5	4	3	2	1	0	4		3	2	1	0
			MSB				LSB				MSB		LSB		MSB		LSB						
1-5	even	17/1-5	0	0	0	0	0	0	0	0	0	0	0	0	0	0	1	0	1	0	1		
6-10	even	17/6-10	0	0	0	0	0	0	0	0	0	0	0	0	0	0	1	0	1	0	1	0	
11-15	even	17/11-15	0	0	0	0	0	0	0	0	0	0	0	0	1	0	0	1	1	1	0	0	
56-60	even	17/56-60	0	0	0	0	0	0	0	0	0	1	0	1	1	1	1	1	1	1	1	1	
61-65	even	18/1-5	0	0	0	0	0	0	0	0	0	1	1	0	0	0	0	0	0	0	0	0	
116-120	even	18/56-60	0	0	0	0	0	0	0	1	0	0	1	1	1	1	1	1	0	1	0	1	
1-5	odd (blink)	17/1-5	0	0	0	0	0	0	1	0	0	0	0	0	0	0	0	0	0	0	0	0	
116-120	odd (blink)	18/56-60	0	0	0	0	0	0	1	1	0	0	1	1	1	0	0	1	1	0	0	0	

MGG001

CGRAM data bit = logic 1 turns the icon on, data bit = logic 0 turns the icon off.

Data in character codes 0 to 2 define the icon-states when icon blink is disabled or during the even phase when icon blink is enabled.

Data in character codes 4 to 6 define the icon-state during the odd phase when icon blink is enabled (not used for icons when icon blink is disabled).

Fig.17 CGRAM to icon mapping.

## LCD controller/driver

## PCF2113x

**10.5 Normal/Icon mode operation**

IM	CONDITION	V <sub>LCD</sub>
0	character mode	generates V <sub>A</sub>
1	icon mode	generates V <sub>B</sub>

**10.6 Screen configuration**

L: default is L = logic 0.

L = logic 0: the two halves of a split screen are connected in a standard way i.e. column 1/61, 2/62 to 60/120.

L = logic 1: the two halves of a split screen are connected in a mirrored way i.e. column 1/120, 2/119 to 60/61.

This allows single layer PCB or glass layout.

**10.7 Display configuration**

P, Q: default is P, Q = logic 0.

P = logic 1 mirrors the column data.

Q = logic 1 mirrors the row data.

**10.8 TC1, TC2**

Default is TC1, TC2 = logic 0. This selects the default temperature coefficient for the internally generated V<sub>LCD</sub>. TC1, TC2 = 10, 01 and 11 selects alternative temperature coefficients 1, 2 and 3 respectively.

**10.9 Set V<sub>LCD</sub>**

V<sub>LCD</sub> value is programmed by instruction. Two on-chip registers hold V<sub>LCD</sub> values for character mode and icon mode respectively (V<sub>A</sub> and V<sub>B</sub>). The generated V<sub>LCD</sub> value is independent of V<sub>DD</sub>, allowing battery operation of the chip. V<sub>B</sub> must be programmed to FF in character mode (i.e. using V<sub>A</sub>) and V<sub>A</sub> must be programmed to 00 in icon mode.

**Note: If internally generated V<sub>LCD</sub> must not be lower than V<sub>DD</sub>.**

Note: V<sub>DD</sub> ≤ 4V

V<sub>LCD</sub> programming:

- send 'Function set' instruction with H = 1
- send 'Set V<sub>LCD</sub>' instruction to write to voltage register:
  - DB7, DB6 = 10: DB5 to DB0 are V<sub>LCD</sub> of character mode (V<sub>A</sub>)
  - DB7, DB6 = 11: DB5 to DB0 are V<sub>LCD</sub> of icon mode (V<sub>B</sub>)
  - DB5 to DB0 = 000000 switches V<sub>LCD</sub> generator off (when selected)
  - During 'display off' and power-down V<sub>LCD</sub> generator is also disabled
- send 'Function set' instruction with H = 0 to resume normal programming.

**10.10 Reducing current consumption**

Reducing current consumption can be achieved by one of the options mentioned in Table 10.

**Table 10** Reducing current consumption

ORIGINAL MODE	ALTERNATIVE MODE
Character mode	icon mode (control bit IM)
Display on	display off (control bit D)

When V<sub>LCD</sub> lies outside the V<sub>DD</sub> range and must be generated, it is usually more efficient to use the on-chip generator than an external regulator.

**Table 11** Use of the V<sub>A</sub> and V<sub>B</sub> registers

MODE	V <sub>A</sub>	V <sub>B</sub>
Normal operation	V <sub>LCD</sub> character mode	V <sub>LCD</sub> icon mode

## LCD controller/driver

## PCF2113x

**11 INTERFACE TO MICROCONTROLLER  
(PARALLEL INTERFACE)**

The PCF2113x can send data in either two 4-bit operations or one 8-bit operation and can thus interface to 4-bit or 8-bit microcontrollers.

In 8-bit mode data is transferred as 8-bit bytes using the 8 data lines DB7 to DB0. Three further control lines E, RS, and  $R/\overline{W}$  are required. See Chapter 7.

In 4-bit mode data is transferred in two cycles of 4 bits each using pins DB7 to DB4 for transaction. The higher order bits (corresponding to DB7 to DB4 in 8-bit mode) are sent in the first cycle and the lower order bits (DB3 to DB0 in 8-bit mode) in the second. Data transfer is complete after two 4-bit data transfers. Note that two cycles are also required for the Busy Flag check. 4-bit operation is selected by instruction. See Figs 14 to 17 for examples of bus protocol.

In 4-bit mode pins DB3 to DB0 must be left open-circuit. They are pulled up to  $V_{DD}$  internally.

**12 INTERFACE TO MICROCONTROLLER  
(I<sup>2</sup>C-BUS INTERFACE)****12.1 Characteristics of the I<sup>2</sup>C-bus**

The I<sup>2</sup>C-bus is for bidirectional, two-line communication between different ICs or modules. The two lines are a serial data line (SDA) and a Serial Clock Line (SCL). Both lines must be connected to a positive supply via a pull-up resistor. Data transfer may be initiated only when the bus is not busy.

Each byte of eight bits is followed by an acknowledge bit. The acknowledge bit is a HIGH level signal put on the bus by the transmitter during which time the master generates an extra acknowledge related clock pulse. A slave receiver which is addressed must generate an acknowledge after the reception of each byte. Also a master receiver must generate an acknowledge after the reception of each byte that has been clocked out of the slave transmitter.

The device that acknowledges must pull-down the SDA line during the acknowledge clock pulse, so that the SDA line is stable LOW during the HIGH period of the acknowledge related clock pulse (set-up and hold times must be taken into consideration). A master receiver must signal an end of data to the transmitter by not generating an acknowledge on the last byte that has been clocked out of the slave. In this event the transmitter must leave the data line HIGH to enable the master to generate a STOP condition.

**12.2 I<sup>2</sup>C-bus protocol**

Before any data is transmitted on the I<sup>2</sup>C-bus, the device which should respond is addressed first. The addressing is always carried out with the first byte transmitted after the start procedure. The I<sup>2</sup>C-bus configuration for the different PCF2113x read and write cycles is shown in Figs 23 and 24. The slow down feature of the I<sup>2</sup>C-bus protocol (receiver holds SCL low during internal operations) is not used in the PCF2113x.

**12.3 Definitions**

- Transmitter: the device which sends the data to the bus
- Receiver: the device which receives the data from the bus
- Master: the device which initiates a transfer, generates clock signals and terminates a transfer
- Slave: the device addressed by a master
- Multi-Master: more than one master can attempt to control the bus at the same time without corrupting the message
- Arbitration: procedure to ensure that, if more than one master simultaneously tries to control the bus, only one is allowed to do so and the message is not corrupted
- Synchronization: procedure to synchronize the clock signals of two or more devices.

LCD controller/driver

PCF2113x

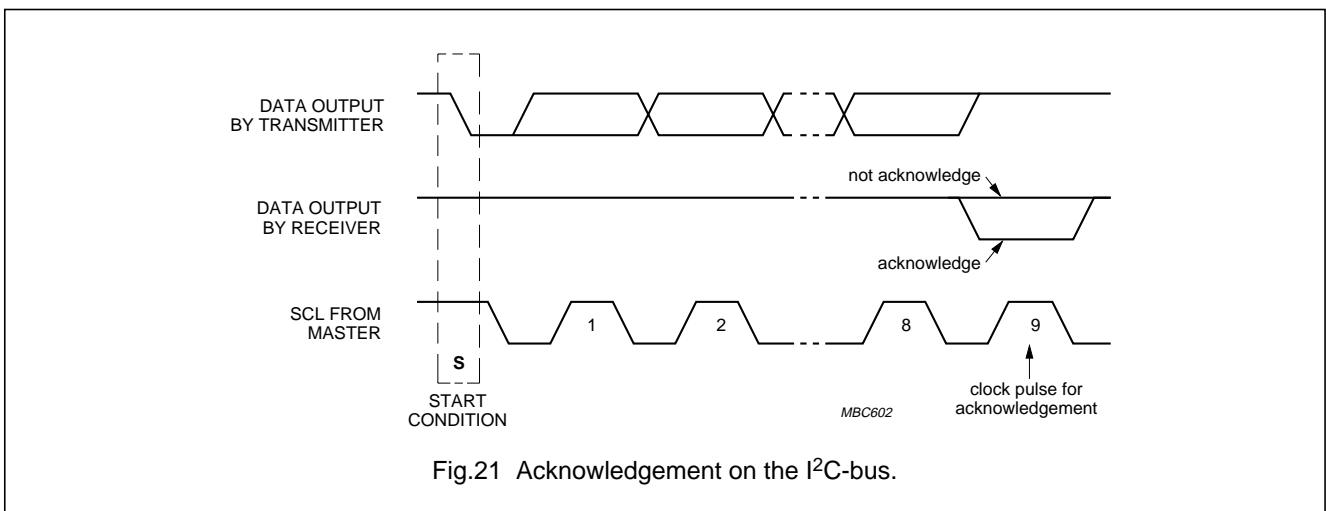
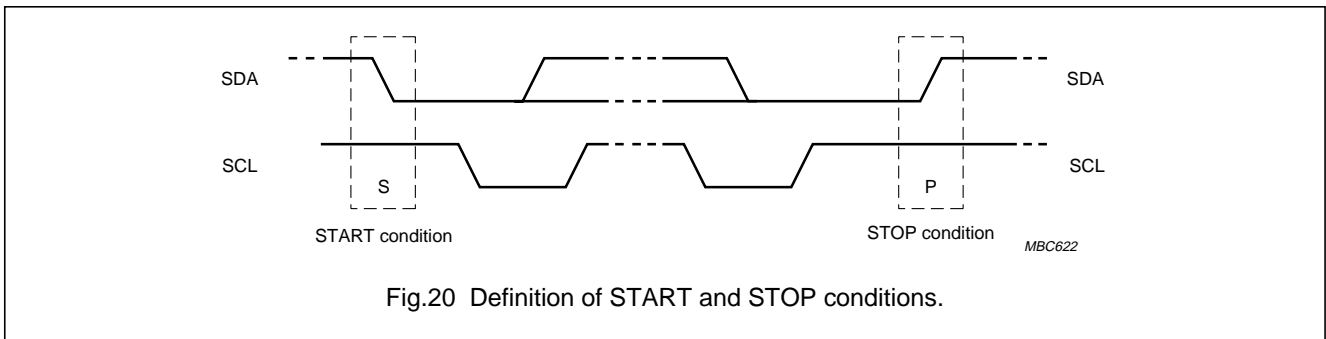
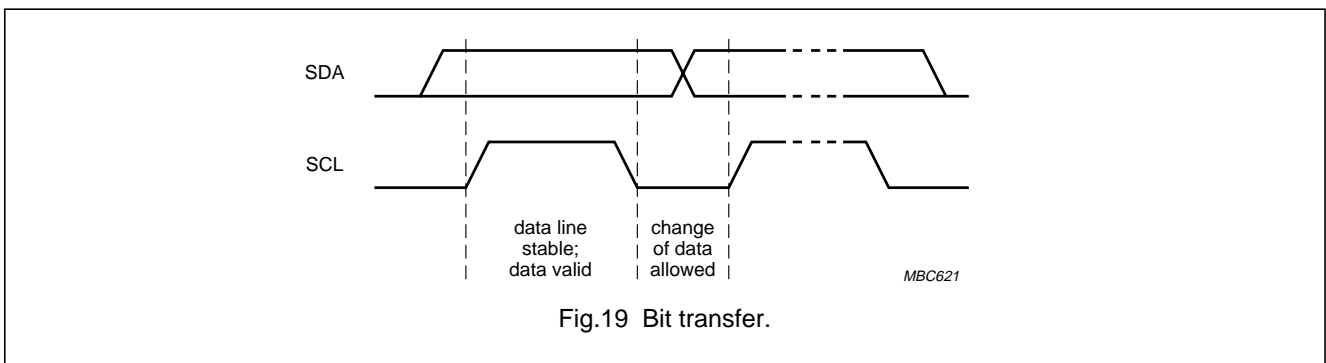
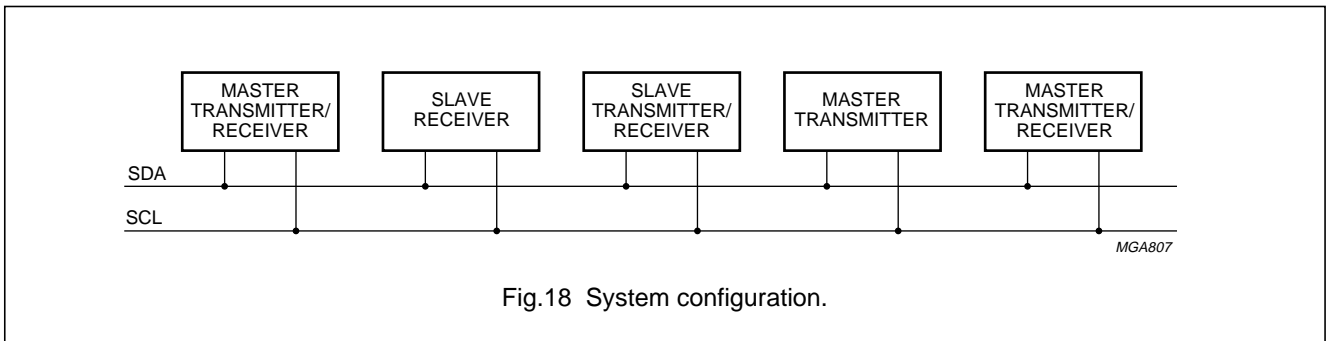

LCD controller/driver

PCF2113X

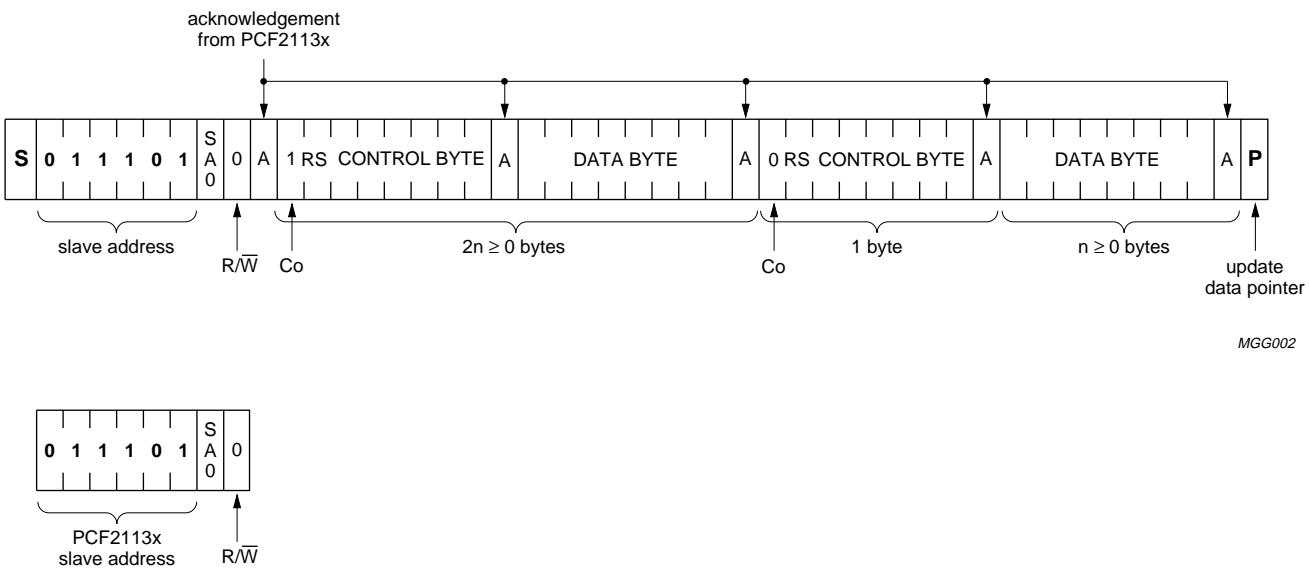
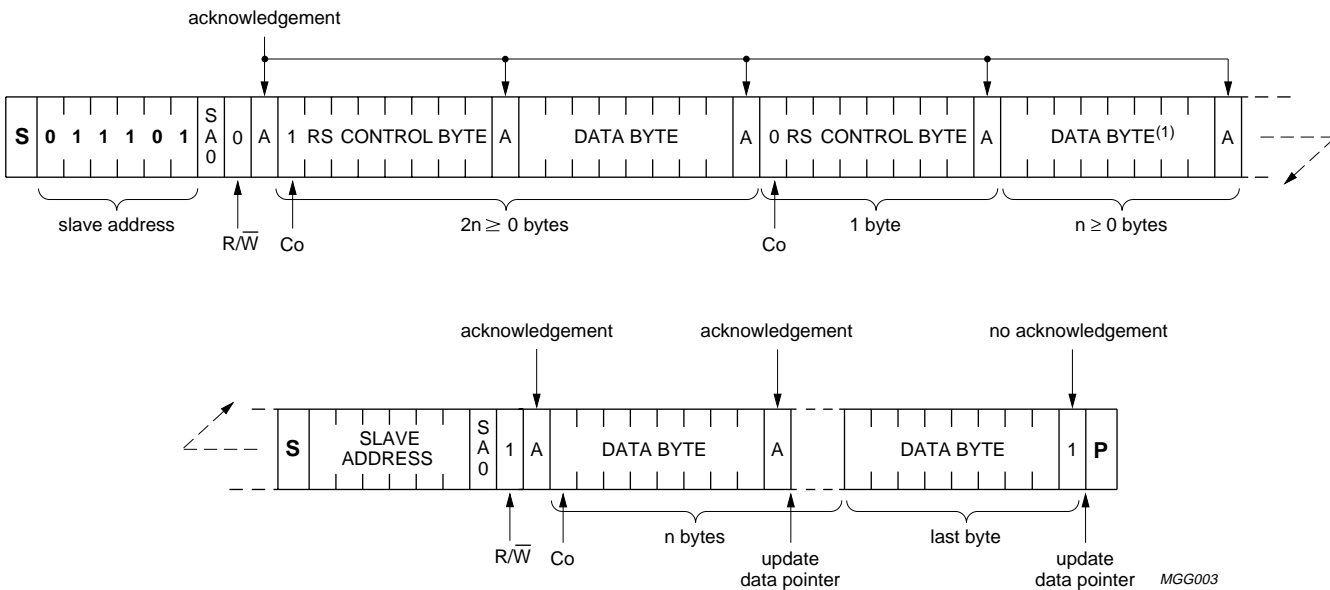

Fig.22 Master transmits to slave receiver; write mode.



LCD controller/driver

PCF2113X



(1) Last data byte is a dummy byte (may be omitted).

Fig.23 Master reads after setting word address; write word address, set RS; 'read data'.

MGG003

LCD controller/driver

PCF2113x

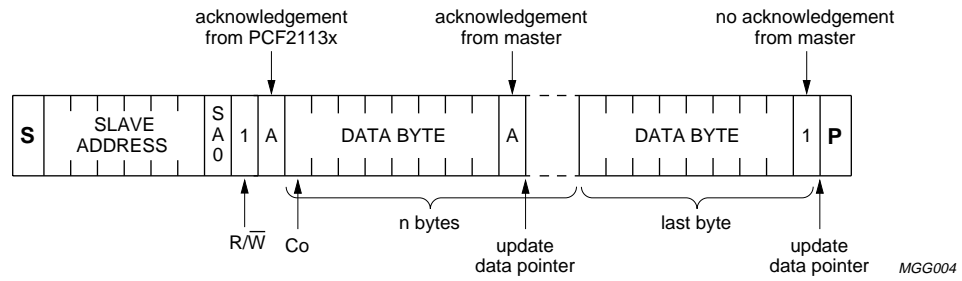

Fig.24 Master reads slave immediately after first byte; read mode (RS previously defined).

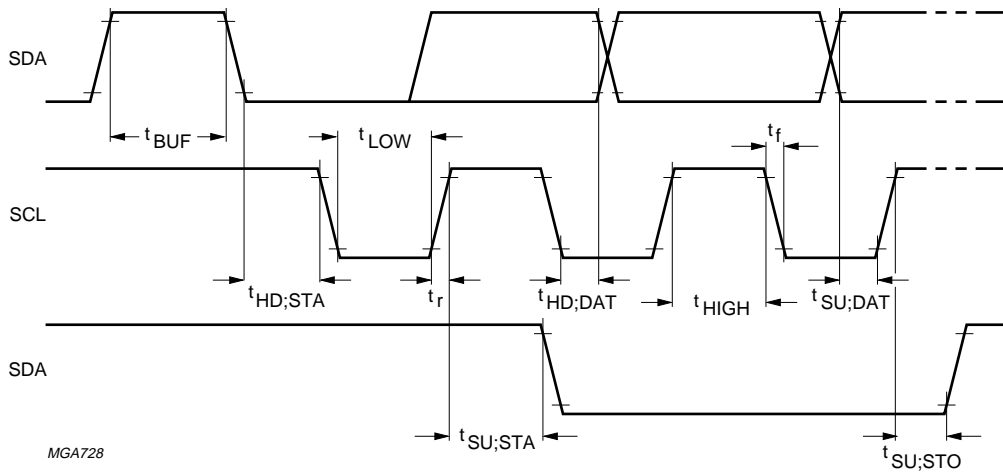

Fig.25 I<sup>2</sup>C-bus timing diagram.

## LCD controller/driver

## PCF2113x

**13 LIMITING VALUES**

In accordance with the Absolute Maximum Rating System (IEC 134).

SYMBOL	PARAMETER	MIN.	MAX.	UNIT
$V_{DD}$	supply voltage	-0.5	+6.5	V
$V_{LCD}$	LCD supply voltage	-0.5	+7.5	V
$V_I$	input voltage OSC, RS, $\overline{R/W}$ , E and DB7 to DB0	-0.5	$V_{DD} + 0.5$	V
$V_O$	output voltage R1 to R18, C1 to C60 and $V_{LCD}$	-0.5	$V_{LCD} + 0.5$	V
$I_I$	DC input current	-10	+10	mA
$I_O$	DC output current	-10	+10	mA
$I_{DD}, I_{SS}, I_{LCD}$	$V_{DD}, V_{SS}$ or $V_{LCD}$ current	-50	+50	mA
$P_{tot}$	total power dissipation	-	400	mW
$P_O$	power dissipation per output	-	100	mW
$T_{stg}$	storage temperature	-65	+150	°C

**14 HANDLING**

Inputs and outputs are protected against electrostatic discharge in normal handling. However, to be totally safe, it is desirable to take normal precautions appropriate to handling MOS devices (see "Handling MOS Devices").

## LCD controller/driver

## PCF2113x

**15 DC CHARACTERISTICS**

$V_{DD} = 1.8$  to  $4.0$  V (external  $V_{LCD}$ :  $V_{DD} = 1.8$  to  $5.5$  V);  $V_{SS} = 0$  V;  $V_{LCD} = 2.2$  to  $6.5$  V;  $T_{amb} = -40$  to  $+85$  °C; unless otherwise specified.

SYMBOL	PARAMETER	CONDITIONS	MIN.	TYP.	MAX.	UNIT
<b>Supplies</b>						
$V_{DD}$	supply voltage	internal $V_{LCD}$ generation	1.8	–	4.0	V
$V_{DD}$	supply voltage	external $V_{LCD}$	1.8	–	5.5	V
$V_{LCD}$	LCD supply voltage		2.2	–	6.5	V
$I_{SS}$	supply current, external $V_{LCD}$	note 1				
$I_{SS1}$	supply current 1		–	60	120	$\mu$ A
$I_{SS3}$	supply current 3	$V_{DD} = 3$ V; $V_{LCD} = 5$ V; note 2	–	45	80	$\mu$ A
$I_{SS4}$	supply current 4 (icon mode)	$V_{DD} = 3$ V; $V_{LCD} = 2.5$ V; note 2	–	25	45	$\mu$ A
$I_{SS5}$	supply current 5 (power-down mode)	$V_{DD} = 3$ V; $V_{LCD} = 2.5$ V; DB7 to DB0, RS, R/W = 1; OSC = 0; PD = 1	–	0.5	5	$\mu$ A
$I_{SS}$	supply current, internal $V_{LCD}$	notes 1, 3				
$I_{SS6}$	supply current 6		–	200	400	$\mu$ A
$I_{SS8}$	supply current 8	$V_{DD} = 3$ V; $V_{LCD} = 5$ V; note 2	–	200	400	$\mu$ A
$I_{SS9}$	supply current 9 (icon mode)	$V_{DD} = 3$ V; $V_{LCD} = 2.5$ V; note 2	–	100	–	$\mu$ A
$V_{POR}$	Power-on reset voltage level	note 4	–	1.3	1.6	V
<b>Logic</b>						
$V_{IL1}$	LOW level input voltage T1, E, RS, R/W, DB[7..0] and SA0		0	–	$0.3V_{DD}$	V
$V_{IH1}$	HIGH level input voltage T1, E, RS, R/W, DB[7..0] and SA0		$0.7V_{DD}$	–	$V_{DD}$	V
$V_{IL(PD)}$	LOW level input voltage PD		0	–	$0.2V_{DD}$	V
$V_{IH(PD)}$	HIGH level input voltage PD		$0.8V_{DD}$	–	$V_{DD}$	V
$V_{IL(osc)}$	LOW level input voltage OSC		0	–	$V_{DD} - 1.5$	V
$V_{IH(osc)}$	HIGH input voltage OSC		$V_{DD} - 0.1$	–	$V_{DD}$	V
$I_{OL(DB)}$	LOW level output current DB[7..0]	$V_{OL} = 0.4$ V; $V_{DD} = 5$ V	1.6	4	–	mA
$I_{OH(DB)}$	HIGH level output current DB[7..0]	$V_{OH} = 4$ V; $V_{DD} = 5$ V	–1.0	–	–	mA
$I_{pu}$	pull-up current DB[7..0]	$V_i = V_{SS}$	0.04	0.15	1	$\mu$ A
$I_{L1}$	leakage current OSC, E, RS, R/W, DB[7..0] and SA0	$V_i = V_{DD}$ or $V_{SS}$	–1.0	–	+1.0	$\mu$ A

## LCD controller/driver

## PCF2113x

SYMBOL	PARAMETER	CONDITIONS	MIN.	TYP.	MAX.	UNIT
<b>I<sup>2</sup>C-bus</b>						
SDA AND SCL						
V <sub>IL2</sub>	LOW level input voltage		0	–	0.3V <sub>DD</sub>	V
V <sub>IH2</sub>	HIGH level input voltage		0.7V <sub>DD</sub>	–	5.5	V
I <sub>L2</sub>	input leakage current	V <sub>I</sub> = V <sub>DD</sub> or V <sub>SS</sub>	–1	–	+1	μA
C <sub>i</sub>	input capacitance	note 5	–	–	10	pF
I <sub>OL(SDA)</sub>	LOW level output current (SDA)	V <sub>OL</sub> = 0.4 V; V <sub>DD</sub> = 5 V	3	–	–	mA
<b>LCD outputs</b>						
R <sub>ROW</sub>	row output resistance R1 to R18	note 6	–	10	30	kΩ
R <sub>COL</sub>	column output resistance C1 to C60	note 6	–	15	40	kΩ
V <sub>tol1</sub>	bias voltage tolerance R1 to R18 and C1 to C60	note 7	–	20	130	mV
V <sub>tol2a</sub>	V <sub>LCD</sub> tolerance	T <sub>amb</sub> = 25 °C; V <sub>LCD</sub> < 3 V; note 3	–	–	200	mV
V <sub>tol2b</sub>	V <sub>LCD</sub> tolerance	T <sub>amb</sub> = 25 °C; V <sub>LCD</sub> < 4 V; note 3	–	–	350	mV
V <sub>tol2c</sub>	V <sub>LCD</sub> tolerance	T <sub>amb</sub> = 25 °C; V <sub>LCD</sub> < 5 V; note 3	–	–	400	mV
TC0	V <sub>LCD</sub> temperature coefficient 0	note 8	–	–7.6	–	mV/K
TC1	V <sub>LCD</sub> temperature coefficient 1	note 8	–	–8.4	–	mV/K
TC2	V <sub>LCD</sub> temperature coefficient 2	note 8	–	–10.4	–	mV/K
TC3	V <sub>LCD</sub> temperature coefficient 3	note 8	–	–12.4	–	mV/K

**Notes**

- LCD outputs are open-circuit; inputs at V<sub>DD</sub> or V<sub>SS</sub>; bus inactive.
- T<sub>amb</sub> = 25 °C; f<sub>OSC</sub> = 200 kHz.
- LCD outputs are open-circuit; HV generator is on; load current I<sub>VLCD</sub> (at V<sub>LCD</sub>) = 5 μA.
- Resets all logic when V<sub>DD</sub> < V<sub>POR</sub>; 3 OSC clock cycles required.
- Tested on sample basis.
- Resistance of output terminals (R1 to R18 and C1 to C60) with a load current of 20 μA; outputs measured one at a time; external V<sub>LCD</sub>.
- LCD outputs open-circuit; external V<sub>LCD</sub>.
- Temperature coefficient at V<sub>OP</sub> = 5.0 V. Typical range ±2 mV/K.

## LCD controller/driver

## PCF2113x

**16 AC CHARACTERISTICS**

$V_{DD} = 1.8$  to  $5.5$  V;  $V_{SS} = 0$  V;  $V_{LCD} = 2.2 - 6.5$  V;  $T_{amb} = -40$  to  $+85$  °C; unless otherwise specified.

SYMBOL	PARAMETER	CONDITIONS	MIN.	TYP.	MAX.	UNIT
$f_{FR}$	LCD frame frequency (internal clock)	$V_{DD} = 5.0$ V	45	81	147	Hz
$f_{OSC}$	oscillator frequency (not available at any pin)		140	250	450	kHz
$f_{OSC}$	external clock frequency		140	–	450	kHz
$t_{OSCST}$	oscillator start-up time after power-down		–	200	300	$\mu$ s
<b>Bus timing characteristics: parallel interface; note 1</b>						
WRITE OPERATION (WRITING DATA FROM MICROCONTROLLER TO PCF2113X)						
$T_{cy}$	enable cycle time		500	–	–	ns
$PW_{EH}$	enable pulse width		220	–	–	ns
$t_{ASU}$	address set-up time		50	–	–	ns
$t_{AHD}$	address hold time		25	–	–	ns
$t_{DSW}$	data set-up time		60	–	–	ns
$t_{HD}$	data hold time		25	–	–	ns
READ OPERATION (READING DATA FROM PCF2113X TO MICROCONTROLLER)						
$T_{cy}$	enable cycle time		500	–	–	ns
$PW_{EH}$	enable pulse width		220	–	–	ns
$t_{ASU}$	address set-up time		50	–	–	ns
$t_{AH}$	address hold time		25	–	–	ns
$t_{DHD}$	data delay time		–	–	150	ns
$t_{HD}$	data hold time		20	–	100	ns
<b>Timing characteristics: I<sup>2</sup>C-bus interface; note 1</b>						
$f_{SCL}$	SCL clock frequency		–	–	400	kHz
$t_{LOW}$	SCL clock low period		1.3	–	–	$\mu$ s
$t_{HIGH}$	SCL clock high period		0.6	–	–	$\mu$ s
$t_{SU;DAT}$	data set-up time		100	–	–	ns
$t_{HD;DAT}$	data hold time		0	–	–	ns
$t_r$	SCL, SDA rise time		–	–	300	ns
$t_f$	SCL, SDA fall time		–	–	300	ns
$C_B$	capacitive bus line load		–	–	400	pF
$t_{SU;STA}$	set-up time for a repeated START condition		0.6	–	–	$\mu$ s
$t_{HD;STA}$	START condition hold time		0.6	–	–	$\mu$ s
$t_{SU;STO}$	set-up time for STOP condition		0.6	–	–	$\mu$ s
$t_{SW}$	tolerable spike width on bus		–	–	50	ns

**Note**

- All timing values are valid within the operating supply voltage and ambient temperature range and are referenced to  $V_{IL}$  and  $V_{IH}$  with an input voltage swing of  $V_{SS}$  to  $V_{DD}$ .

LCD controller/driver

PCF2113x

17 TIMING CHARACTERISTICS

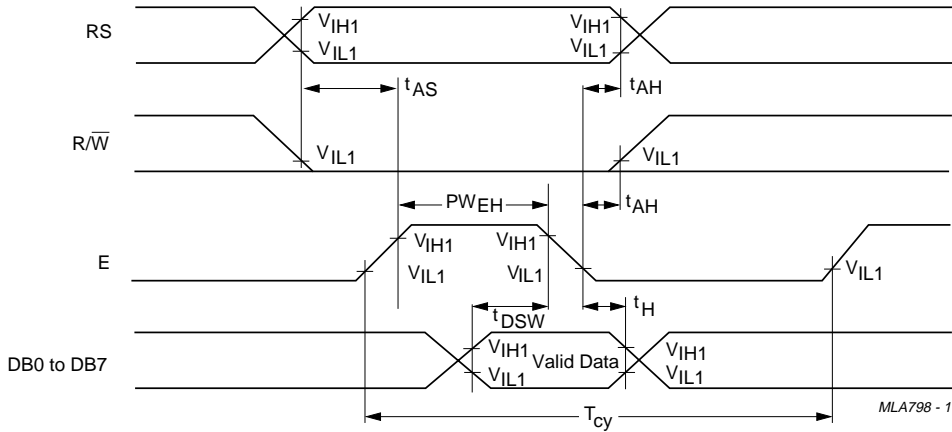

Fig.26 Parallel bus write operation sequence; writing data from microcontroller to PCF2113x.

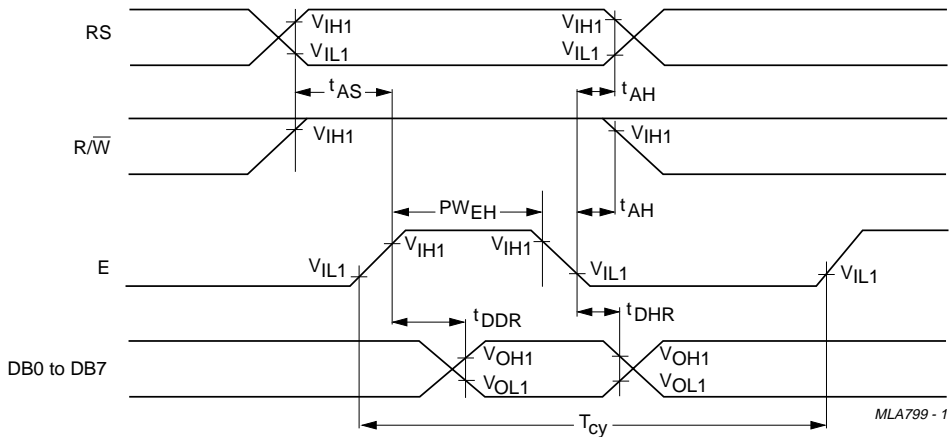

Fig.27 Parallel bus read operation sequence; reading data from PCF2113x to microcontroller.

LCD controller/driver

PCF2113x

18 APPLICATION INFORMATION

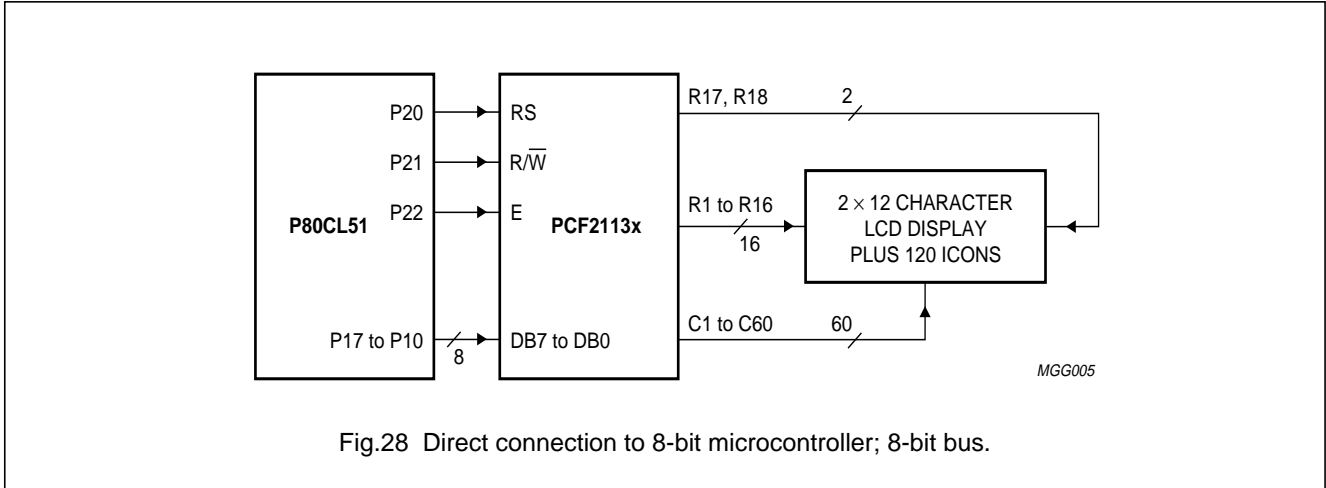

Fig.28 Direct connection to 8-bit microcontroller; 8-bit bus.

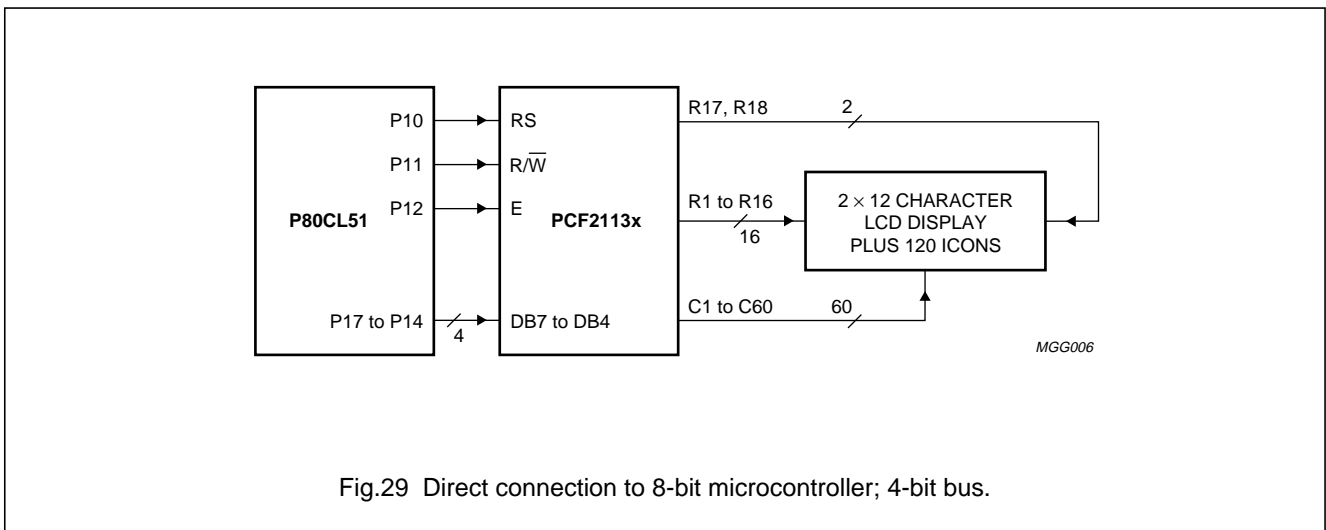

Fig.29 Direct connection to 8-bit microcontroller; 4-bit bus.

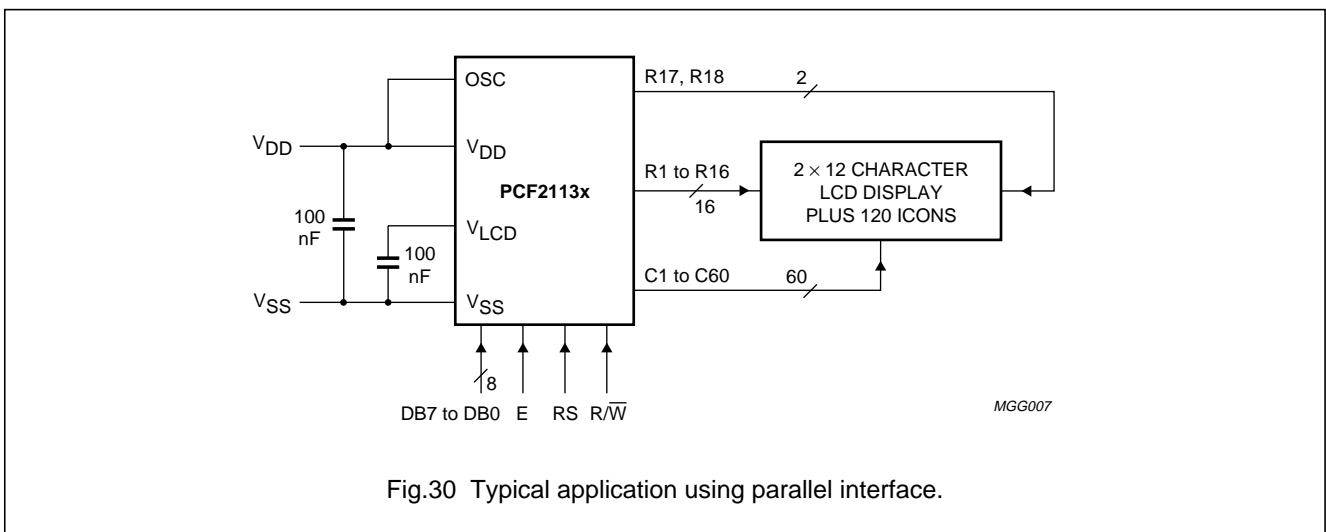

Fig.30 Typical application using parallel interface.





## LCD controller/driver

## PCF2113x

**18.1 8-bit operation, 1-line display using internal reset**

Table 13 shows an example of a 1-line display in 8-bit operation. The PCF2113x functions must be set by the 'function set' instruction prior to display. Since the DDRAM can store data for 80 characters, the RAM can be used for advertising displays when combined with display shift operation. Since the display shift operation changes display position only and DDRAM contents remain unchanged, display data entered first can be displayed when the 'return home' operation is performed.

**18.2 4-bit operation, 1-line display using internal reset**

The program must set functions prior to 4-bit operation. Table 12 shows an example. When power is turned on, 8-bit operation is automatically selected and the PCF2113x attempts to perform the first write as an 8-bit operation. Since nothing is connected to DB0 to DB3, a rewrite is then required.

However, since one operation is completed in two accesses of 4-bit operation, a rewrite is required to set the functions (see Table 12 step 3).

Thus, DB4 to DB7 of the 'function set' are written twice.

**18.3 8-bit operation, 2-line display**

For a 2-line display, the cursor automatically moves from the first to the second line after the 40<sup>th</sup> digit of the first line has been written. Thus, if there are only 8 characters in the first line, the DDRAM address must be set after the eighth character is completed (see Table 5). Note that both lines of the display are always shifted together; data does not shift from one line to the other.

**18.4 I<sup>2</sup>C operation, 1-line display**

A control byte is required with most instructions (see Table 16).

**Table 12** 4-bit operation, 1-line display example; using internal reset

STEP	INSTRUCTION	DISPLAY	OPERATION
1	power supply on (PCF2113x is initialized by the internal reset circuit)		initialized; no display appears
2	function set RS    R/W    DB7    DB6    DB5    DB4 0    0    0    0    1    0		sets to 4-bit operation; in this instance operation is handled as 8-bits by initialization and only this instruction completes with one write
3	function set 0    0    0    0    1    0 0    0    0    0    0    0		sets to 4-bit operation, selects 1-line display and $V_{LCD} = V_0$ ; 4-bit operation starts from this point and resetting is needed
4	display on/off control 0    0    0    0    0    0 0    0    1    1    1    0	—	turns on display and cursor; entire display is blank after initialization
5	entry mode set 0    0    0    0    0    0 0    0    0    1    1    0	—	sets mode to increment the address by 1 and to shift the cursor to the right at the time of write to the DD/CGRAM; display is not shifted
6	'write data' to CGRAM/DDRAM 1    0    0    1    0    1 1    0    0    0    0    0	P_	writes 'P'; the DDRAM has already been selected by initialization at power-on; the cursor is incremented by 1 and shifted to the right

## LCD controller/driver

## PCF2113X

**Table 13** 8-bit operation, 1-line display example; using internal reset (character set 'A')

STEP	INSTRUCTION	DISPLAY	OPERATION
1	power supply on (PCF2113x is initialized by the internal reset function)		initialized; no display appears
2	function set RS R/W DB7 DB6 DB5 DB4 DB3 DB2 DB1 DB0 0 0 0 0 1 1 0 0 0 0		sets to 8-bit operation, selects 1-line display and $V_{LCD} = V_0$
3	display mode on/off control 0 0 0 0 0 0 1 1 1 0	_	turns on display and cursor; entire display is blank after initialization
4	entry mode set 0 0 0 0 0 0 0 1 1 0	_	sets mode to increment the address by 1 and to shift the cursor to the right at the time of the write to the DD/CGRAM; display is not shifted
5	'write data' to CGRAM/DDRAM 1 0 0 1 0 1 0 0 0 0	P_	writes 'P'; the DDRAM has already been selected by initialization at power-on; the cursor is incremented by 1 and shifted to the right
6	'write data' to CGRAM/DDRAM 1 0 0 1 0 0 1 0 0 0	PH_	writes 'H'
7 to 11		 	
12	'write data' to CGRAM/DDRAM 1 0 0 1 0 1 0 0 1 1	PHILIPS_	writes 'S'
13	entry mode set 0 0 0 0 0 0 0 1 1 1	PHILIPS_	sets mode for display shift at the time of write
14	'write data' to CGRAM/DDRAM 1 0 0 0 1 0 0 0 0 0	HILIPS _	writes space
15	'write data' to CGRAM/DDRAM 1 0 0 1 0 0 1 1 0 1	ILIPS M_	writes 'M'
16		 	

## LCD controller/driver

PCF2113X

STEP	INSTRUCTION	DISPLAY	OPERATION
17	'write data' to CGRAM/DDRAM 1 0 0 1 0 0 1 1 1 1	<b>MICROKO_</b>	writes 'O'
18	cursor/display shift 0 0 0 0 0 1 0 0 0 0	<b>MICROKO</b>	shifts only the cursor position to the left
19	cursor/display shift 0 0 0 0 0 1 0 0 0 0	<b>MICROKO</b>	shifts only the cursor position to the left
20	'write data' to CGRAM/DDRAM 1 0 0 1 0 0 0 0 1 1	<b>ICROCO</b>	writes 'C' correction; the display moves to the left
21	cursor/display shift 0 0 0 0 0 1 1 1 0 0	<b>MICROCO</b>	shifts the display and cursor to the right
22	cursor/display shift 0 0 0 0 0 1 0 1 0 0	<b>MICROCO_</b>	shifts only the cursor to the right
23	'write data' to CGRAM/DDRAM 1 0 0 1 0 0 1 1 0 1	<b>ICROCOM_</b>	writes 'M'
24		   	
25	return home 0 0 0 0 0 0 0 0 1 0	<b>PHILIPS M</b>	returns both display and cursor to the original position (address 0)

## LCD controller/driver

## PCF2113X

**Table 14** 8-bit operation, 1-line display and icon example; using internal reset (character set 'A')

STEP	INSTRUCTION	DISPLAY	OPERATION
1	power supply on (PCF2113x is initialized by the internal reset function)		initialized; no display appears
2	function set RS R/W DB7 DB6 DB5 DB4 DB3 DB2 DB1 DB0 0 0 0 0 1 1 0 0 0 0		sets to 8-bit operation, selects 1-line display and $V_{LCD} = V_0$
3	display mode on/off control 0 0 0 0 0 0 1 1 1 0	—	turns on display and cursor; entire display is blank after initialization
4	entry mode set 0 0 0 0 0 0 0 1 1 0	—	sets mode to increment the address by 1 and to shift the cursor to the right at the time of the write to the DD/CGRAM; display is not shifted
5	set CGRAM address 0 0 0 1 0 0 0 0 0 0	—	sets the CGRAM address to position of character 0; the CGRAM is selected
6	'write data' to CGRAM/DDRAM 1 0 0 0 0 0 1 0 1 0	—	writes data to CGRAM for icon even phase; icons appears
7		 	
8	set CGRAM address 0 0 0 1 1 1 0 0 0 0	—	sets the CGRAM address to position of character 4; the CGRAM is selected
9	'write data' to CGRAM/DDRAM 1 0 0 0 0 0 1 0 1 0	—	writes data to CGRAM for icon odd phase
10		 	
11	function set 0 0 0 0 1 1 0 0 0 1	—	sets H = 1
12	icon control 0 0 0 0 0 0 1 0 1 0	—	icons blink
13	function set 0 0 0 0 1 1 0 0 0 1	—	sets H = 0

## LCD controller/driver

PCF2113X

STEP	INSTRUCTION	DISPLAY	OPERATION
14	set DDRAM address 0 0 1 0 0 0 0 0 0 0		sets the DDRAM address to the first position; DDRAM is selected
15	'write data' to CGRAM/DDRAM 1 0 0 1 0 1 0 0 0 0	<b>P_</b>	writes 'P'; the cursor is incremented by 1 and shifted to the right
16	'write data' to CGRAM/DDRAM 1 0 0 1 0 0 1 0 0 0	<b>PH_</b>	writes 'H'
17 to 20		 	
21	return home 0 0 0 0 0 0 0 0 1 0	<b><u>PHILIPS</u></b>	returns both display and cursor to the original position (address 0)

## LCD controller/driver

## PCF2113X

**Table 15** 8-bit operation, 2-line display example; using internal reset

STEP	INSTRUCTION	DISPLAY	OPERATION
1	power supply on (PCF2113x is initialized by the internal reset function)		initialized; no display appears
2	function set  RS R/W DB7 DB6 DB5 DB4 DB3 DB2 DB1 DB0 0 0 0 0 1 1 1 0 0 0		sets to 8-bit operation; selects 2-line display and voltage generator off
3	display on/off control  0 0 0 0 0 0 1 1 1 0	—	turns on display and cursor; entire display is blank after initialization
4	entry mode set  0 0 0 0 0 0 0 1 1 0	—	sets mode to increment the address by 1 and to shift the cursor to the right at the time of write to the CG/DDRAM; display is not shifted
5	'write data' to CGRAM/DDRAM  1 0 0 1 0 1 0 0 0 0	P_	writes 'P'; the DDRAM has already been selected by initialization at power-on; the cursor is incremented by 1 and shifted to the right
6 to 10		   	
11	'write data' to CGRAM/DDRAM  1 0 0 1 0 1 0 0 1 1	PHILIPS_	writes 'S'
12	set DDRAM address  0 0 1 1 0 0 0 0 0 0	PHILIPS —	sets DDRAM address to position the cursor at the head of the 2nd line
13	'write data' to CGRAM/ DDRAM  1 0 0 1 0 0 1 1 0 1	PHILIPS M_	writes 'M'
14 to 19		   	

## LCD controller/driver

PCF2113X

STEP	INSTRUCTION	DISPLAY	OPERATION
20	'write data' to CGRAM/DDRAM 1 0 0 1 0 0 1 1 1 1	PHILIPS	writes 'O'
		MICROCO_	
21	'write data' to CGRAM/DDRAM 0 0 0 0 0 0 0 1 1 1	PHILIPS	sets mode for display shift at the time of write
		MICROCO_	
22	'write data' to CGRAM/DDRAM 1 0 0 1 0 0 1 1 0 1	HILIPS	writes 'M'; display is shifted to the left; the first and second lines shift together
		ICROCOM_	
23		   	
24	return home 0 0 0 0 0 0 0 0 1 0	PHILIPS	returns both display and cursor to the original position (address 0)
		MICROCOM	



## LCD controller/driver

## PCF2113X

**Table 16** Example of I<sup>2</sup>C operation; 1-line display (using internal reset, assuming SA0 = V<sub>SS</sub>; note 1)

STEP	I <sup>2</sup> C BYTE	DISPLAY	OPERATION
1	I <sup>2</sup> C start		initialized; no display appears
2	slave address for write SA6 SA5 SA4 SA3 SA2 SA1 SA0 R/W Ack 0 1 1 1 0 1 0 0 1		during the acknowledge cycle SDA will be pulled-down by the PCF2113x
3	send a control byte for 'function set' Co RS 0 0 0 0 0 0 Ack 0 0 0 0 0 0 0 0 1		control byte sets RS for following data bytes
4	function set DB7 DB6 DB5 DB4 DB3 DB2 DB1 DB0 Ack 0 0 1 X 0 0 0 0 1		selects 1-line display and V <sub>LCD</sub> = V <sub>0</sub> ; SCL pulse during acknowledge cycle starts execution of instruction
5	display on/off control DB7 DB6 DB5 DB4 DB3 DB2 DB1 DB0 Ack 0 0 0 0 1 1 1 0 1	–	turns on display and cursor; entire display shows character 20H (blank in ASCII-like character sets)
6	entry mode set DB7 DB6 DB5 DB4 DB3 DB2 DB1 DB0 Ack 0 0 0 0 0 1 1 0 1	–	sets mode to increment the address by 1 and to shift the cursor to the right at the time of write to the DDRAM or CGRAM; display is not shifted
7	I <sup>2</sup> C start	–	for writing data to DDRAM, RS must be set to 1; therefore a control byte is needed
8	slave address for write SA6 SA5 SA4 SA3 SA2 SA1 SA0 R/W Ack 0 1 1 1 0 1 0 0 1	–	
9	send a control byte for 'write data' Co RS 0 0 0 0 0 0 Ack 0 1 0 0 0 0 0 0 1	–	
10	'write data' to DDRAM DB7 DB6 DB5 DB4 DB3 DB2 DB1 DB0 Ack 0 1 0 1 0 0 0 0 1	P_	writes 'P'; the DDRAM has been selected at power-up; the cursor is incremented by 1 and shifted to the right

## LCD controller/driver

## PCF2113X

STEP	I <sup>2</sup> C BYTE	DISPLAY	OPERATION
11	'write data' to DDRAM DB7 DB6 DB5 DB4 DB3 DB2 DB1 DB0 Ack 0 1 0 0 1 0 0 0 1	PH_	writes 'H'
12 to 15			
16	'write data' to DDRAM DB7 DB6 DB5 DB4 DB3 DB2 DB1 DB0 Ack 0 1 0 1 0 0 1 1 1	PHILIPS_	writes 'S'
17	(optional I <sup>2</sup> C stop) I <sup>2</sup> C start + slave address for write (as step 8)	PHILIPS_	
18	control byte Co RS 0 0 0 0 0 0 Ack 1 0 0 0 0 0 0 0 1	PHILIPS_	
19	return home DB7 DB6 DB5 DB4 DB3 DB2 DB1 DB0 Ack 0 0 0 0 0 0 1 0 1	PHILIPS	sets DDRAM address 0 in Address Counter (also returns shifted display to original position; DDRAM contents unchanged); this instruction does not update the Data Register (DR)
20	I <sup>2</sup> C start	PHILIPS	
21	slave address for read SA6 SA5 SA4 SA3 SA2 SA1 SA0 R/W Ack 0 1 1 1 0 1 0 1 1	PHILIPS	during the acknowledge cycle the content of the DR is loaded into the internal I <sup>2</sup> C interface to be shifted out; in the previous instruction neither a 'set address' nor a 'read data' has been performed; therefore the content of the DR was unknown. The R/W has to be set to 1 while still in I <sup>2</sup> C-write mode.
22	control byte for read Co RS 0 0 0 0 0 0 Ack 0 1 1 0 0 0 0 0 1	PHILIPS	DDRAM content will be read from following instructions

## LCD controller/driver

PCF2113X

STEP	I <sup>2</sup> C BYTE	DISPLAY	OPERATION
23	'read data': 8 × SCL + master acknowledge; note 2 DB7 DB6 DB5 DB4 DB3 DB2 DB1 DB0 Ack X X X X X X X X 0	<b>PHILIPS</b>	8 × SCL; content loaded into interface during previous acknowledge cycle is shifted out over SDA; MSB is DB7; during master acknowledge content of DDRAM address 01 is loaded into the I <sup>2</sup> C interface
24	'read data': 8 × SCL + master acknowledge; note 2 DB7 DB6 DB5 DB4 DB3 DB2 DB1 DB0 Ack 0 1 0 0 1 0 0 0 0	<b>PHILIPS</b>	8 × SCL; code of letter 'H' is read first; during master acknowledge code of 'I' is loaded into the I <sup>2</sup> C interface
25	'read data': 8 × SCL + no master acknowledge; note 2 DB7 DB6 DB5 DB4 DB3 DB2 DB1 DB0 Ack 0 1 0 0 1 0 0 1 1	<b>PHILIPS</b>	no master acknowledge; after the content of the I <sup>2</sup> C interface register is shifted out no internal action is performed; no new data is loaded to the interface register, Data Register (DR) is not updated, Address Counter (AC) is not incremented and cursor is not shifted
26	I <sup>2</sup> C stop	<b>PHILIPS</b>	

**Notes**

1. X = don't care.
2. SDA is left at high-impedance by the microcontroller during the read acknowledge.

## LCD controller/driver

## PCF2113X

**Table 17** Initialization by instruction, 8-bit interface (note 1)

STEP										DESCRIPTION
power-on or unknown state										
wait 2 ms after $V_{DD}$ rises above $V_{POR}$										
RS	$\overline{R/\overline{W}}$	DB7	DB6	DB5	DB4	DB3	DB2	DB1	DB0	BF cannot be checked before this instruction
0	0	0	0	1	1	X	X	X	X	function set (interface is 8 bits long)
wait 2 ms										
RS	$\overline{R/\overline{W}}$	DB7	DB6	DB5	DB4	DB3	DB2	DB1	DB0	BF cannot be checked before this instruction
0	0	0	0	1	1	X	X	X	X	function set (interface is 8 bits long)
wait more than 40 $\mu$ s										
RS	$\overline{R/\overline{W}}$	DB7	DB6	DB5	DB4	DB3	DB2	DB1	DB0	BF cannot be checked before this instruction
0	0	0	0	1	1	X	X	X	X	function set (interface is 8 bits long)
										BF can be checked after the following instructions; when BF is not checked, the waiting time between instructions is the specified instruction time (see Table 3)
RS	$\overline{R/\overline{W}}$	DB7	DB6	DB5	DB4	DB3	DB2	DB1	DB0	function set (interface is 8 bits long); specify the number of display lines.
0	0	0	0	1	1	0	M	0	H	
0	0	0	0	0	0	1	0	0	0	display off
0	0	0	0	0	0	0	0	0	1	clear display
0	0	0	0	0	0	0	1	I/D	S	entry mode set
Initialization ends										

**Note**

1. X = don't care.

## LCD controller/driver

## PCF2113X

**Table 18** Initialization by instruction, 4-bit interface; not applicable for I<sup>2</sup>C-bus operation

STEP						DESCRIPTION
Power-on or unknown state						
Wait 2 ms after V <sub>DD</sub> rises above V <sub>POR</sub>						
RS	R/W	DB7	DB6	DB5	DB4	BF cannot be checked before this instruction
0	0	0	0	1	1	function set (interface is 8 bits long)
Wait 2 ms						
RS	R/W	DB7	DB6	DB5	DB4	BF cannot be checked before this instruction
0	0	0	0	1	1	function set (interface is 8 bits long)
Wait 40 μs						
RS	R/W	DB7	DB6	DB5	DB4	BF cannot be checked before this instruction
0	0	0	0	1	1	function set (interface is 8 bits long)
						BF can be checked after the following instructions; when BF is not checked, the waiting time between instructions is the specified instruction time (see Table 3)
RS	R/W	DB7	DB6	DB5	DB4	function set (set interface to 4 bits long)
0	0	0	0	1	0	interface is 8 bits long
0	0	0	0	1	0	function set (interface is 4 bits long)
0	0	0	M	0	H	specify number of display lines
0	0	0	0	0	0	display off
0	0	1	0	0	0	
0	0	0	0	0	0	clear display
0	0	0	0	0	1	entry mode set
0	0	0	0	0	0	
0	0	0	1	I/D	S	
Initialization ends						

LCD controller/driver

PCF2113x

19 BONDING PAD LOCATIONS

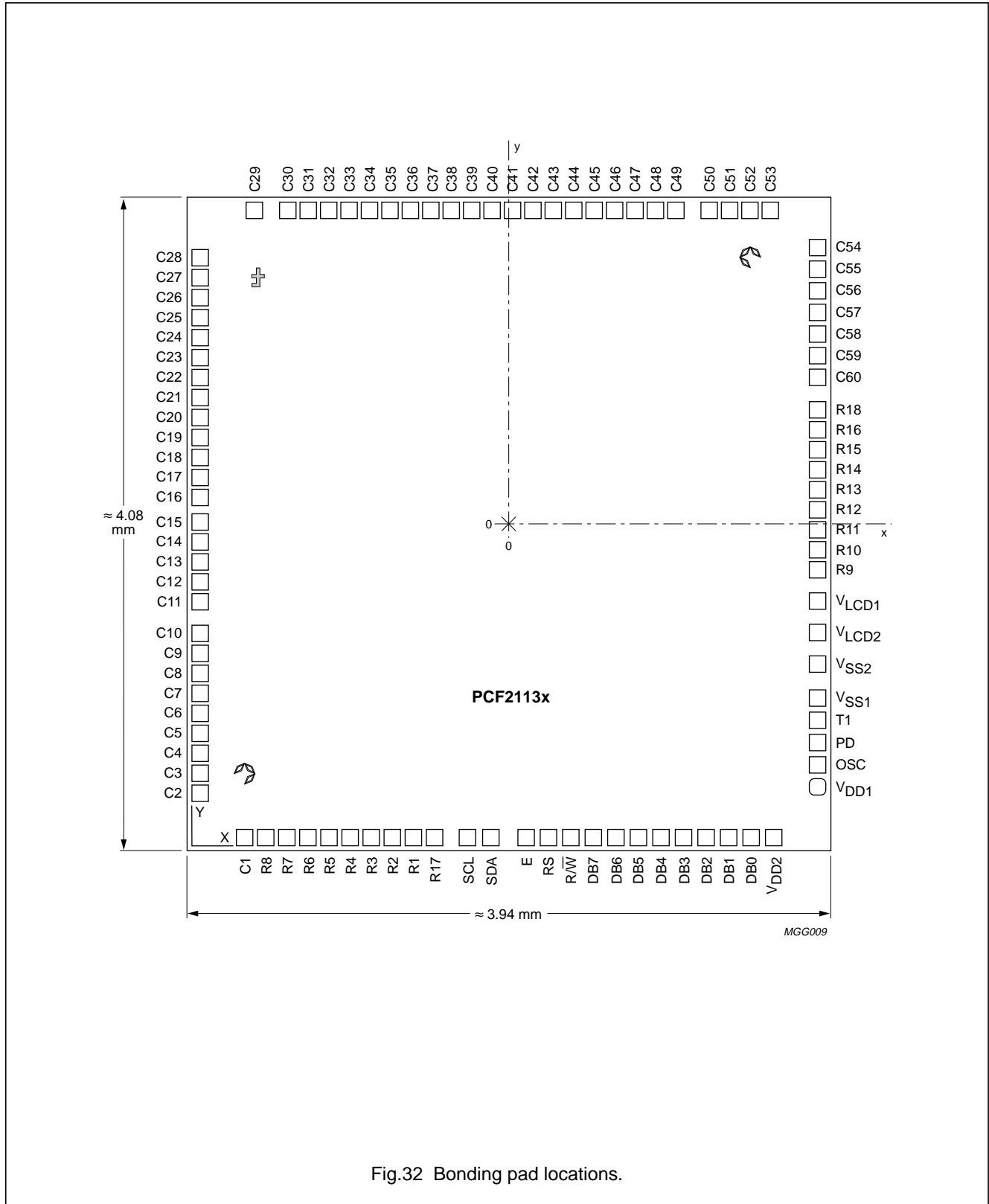

Fig.32 Bonding pad locations.

## LCD controller/driver

## PCF2113x

**Table 19** Bonding pad locations (dimensions in  $\mu\text{m}$ )  
All x/y coordinates are referenced to centre of chip (see Fig.32).

SYMBOL	PAD	X	Y
V <sub>DD1</sub>	1	1811.3	-1547.1
OSC	2	1811.3	-1416.5
PD	3	1811.3	-1285.9
T1	4	1811.3	-1155.3
V <sub>SS1</sub>	5	1811.3	-1024.7
V <sub>SS2</sub>	6	1811.3	-822.1
V <sub>LCD2</sub>	7	1811.3	-633.9
V <sub>LCD1</sub>	8	1811.3	-446.3
R9	9	1811.3	-264.0
R10	10	1811.3	-144.0
R11	11	1811.3	-24.0
R12	12	1811.3	96.0
R13	13	1811.3	216.0
R14	14	1811.3	336.0
R15	15	1811.3	456.0
R16	16	1811.3	576.0
R18	17	1811.3	696.0
C60	18	1811.3	889.4
C59	19	1811.3	1009.4
C58	20	1811.3	1129.4
C57	21	1811.3	1249.4
C56	22	1811.3	1369.4
C55	23	1811.3	1489.4
C54	24	1811.3	1609.4
C53	25	1536.5	1877.7
C52	26	1416.5	1877.7
C51	27	1296.5	1877.7
C50	28	1176.5	1877.7
C49	29	983.9	1877.7
C48	30	863.9	1877.7
C47	31	743.9	1877.7
C46	32	623.9	1877.7
C45	33	503.9	1877.7
C44	34	383.9	1877.7
C43	35	263.9	1877.7
C42	36	143.9	1877.7
C41	37	23.9	1877.7
C40	38	-96.1	1877.7L

SYMBOL	PAD	X	Y
C39	39	-216.1	1877.7
C38	40	-336.1	1877.7
C37	41	-456.1	1877.7
C36	42	-576.1	1877.7
C35	43	-696.1	1877.7
C34	44	-816.1	1877.7
C33	45	-936.1	1877.7
C32	46	-1056.1	1877.7
C31	47	-1176.1	1877.7
C30	48	-1296.1	1877.7
C29	49	-1488.7	1877.7
C28	50	-1811.3	1609.4
C27	51	-1811.3	1489.4
C26	52	-1811.3	1369.4
C25	53	-1811.3	1249.4
C24	54	-1811.3	1129.4
C23	55	-1811.3	1009.4
C22	56	-1811.3	889.4
C21	57	-1811.3	769.4
C20	58	-1811.3	649.4
C19	59	-1811.3	529.4
C18	60	-1811.3	409.4
C17	61	-1811.3	289.4
C16	62	-1811.3	169.4
C15	63	-1811.3	23.2
C14	64	-1811.3	-96.8
C13	65	-1811.3	-216.8
C12	66	-1811.3	-336.8
C11	67	-1811.3	-456.8
C10	68	-1811.3	-649.4
C9	69	-1811.3	-769.4
C8	70	-1811.3	-889.4
C7	71	-1811.3	-1009.4
C6	72	-1811.3	-1129.4
C5	73	-1811.3	-1249.4
C4	74	-1811.3	-1369.4
C3	75	-1811.3	-1489.4
C2	76	-1811.3	-1609.4

## LCD controller/driver

## PCF2113x

SYMBOL	PAD	X	Y
C1	77	-1542.7	-1877.7
R8	78	-1422.4	-1877.7
R7	79	-1302.4	-1877.7
R6	80	-1182.4	-1877.7
R5	81	-1062.4	-1877.7
R4	82	-942.4	-1877.7
R3	83	-822.4	-1877.7
R2	84	-702.4	-1877.7
R1	85	-582.4	-1877.7
R17	86	-462.4	-1877.7
SCL	87	-271.2	-1877.7
SDA	88	-130.2	-1877.7
E	89	74.4	-1877.7
RS	90	205.1	-1877.7
RW	91	335.7	-1877.7
DB7	92	468.8	-1877.7
DB6	93	603.8	-1877.7
DB5	94	738.8	-1877.7
DB4	95	873.8	-1877.7
DB3	96	1008.8	-1877.7
DB2	97	1143.8	-1877.7
DB1	98	1278.8	-1877.7
DB0	99	1413.8	-1877.7
V <sub>DD2</sub>	100	1546.0	-1877.7
Sign C1		-1518.0	-1387.7
Sign C2		1405.0	1671.3
Sign f		-1491.0	1602.3



LCD controller/driver

PCF2113x

20 PACKAGE OUTLINE

LQFP100: plastic low profile quad flat package; 100 leads; body 14 x 14 x 1.4 mm

SOT407-1

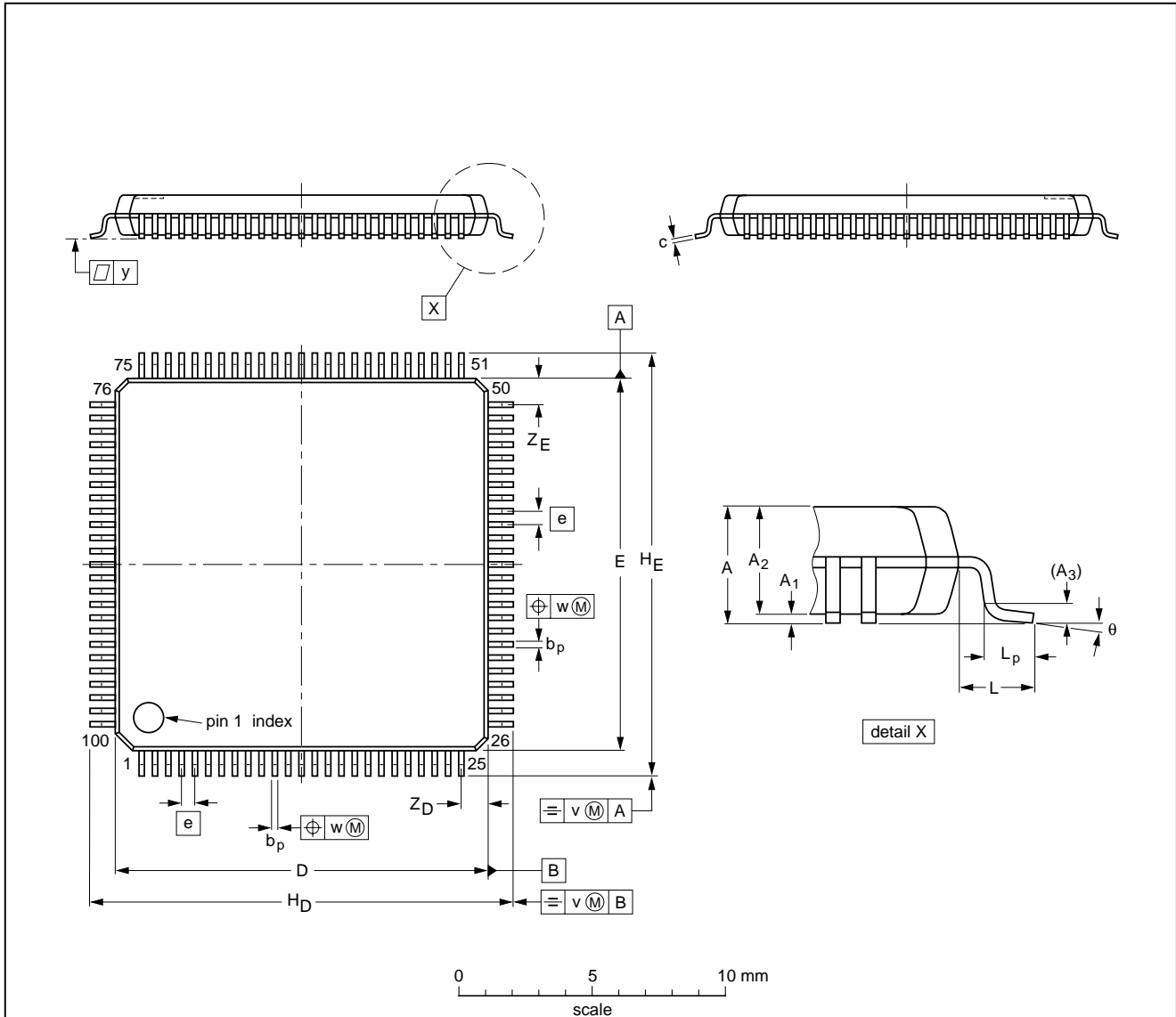

DIMENSIONS (mm are the original dimensions)

UNIT	A max.	A <sub>1</sub>	A <sub>2</sub>	A <sub>3</sub>	b <sub>p</sub>	c	D <sup>(1)</sup>	E <sup>(1)</sup>	e	H <sub>D</sub>	H <sub>E</sub>	L	L <sub>p</sub>	v	w	y	Z <sub>D</sub> <sup>(1)</sup>	Z <sub>E</sub> <sup>(1)</sup>	θ
mm	1.6	0.20 0.05	1.5 1.3	0.25	0.28 0.16	0.18 0.12	14.1 13.9	14.1 13.9	0.5	16.25 15.75	16.25 15.75	1.0	0.75 0.45	0.2	0.12	0.1	1.15 0.85	1.15 0.85	7° 0°

Note

1. Plastic or metal protrusions of 0.25 mm maximum per side are not included.

OUTLINE VERSION	REFERENCES				EUROPEAN PROJECTION	ISSUE DATE
	IEC	JEDEC	EIAJ			
SOT407-1						95-12-19 97-08-04

## LCD controller/driver

## PCF2113x

## 21 SOLDERING

### 21.1 Introduction

There is no soldering method that is ideal for all IC packages. Wave soldering is often preferred when through-hole and surface mounted components are mixed on one printed-circuit board. However, wave soldering is not always suitable for surface mounted ICs, or for printed-circuits with high population densities. In these situations reflow soldering is often used.

This text gives a very brief insight to a complex technology. A more in-depth account of soldering ICs can be found in our "*IC Package Databook*" (order code 9398 652 90011).

### 21.2 Reflow soldering

Reflow soldering techniques are suitable for all LQFP packages.

Reflow soldering requires solder paste (a suspension of fine solder particles, flux and binding agent) to be applied to the printed-circuit board by screen printing, stencilling or pressure-syringe dispensing before package placement.

Several techniques exist for reflowing; for example, thermal conduction by heated belt. Dwell times vary between 50 and 300 seconds depending on heating method. Typical reflow temperatures range from 215 to 250 °C.

Preheating is necessary to dry the paste and evaporate the binding agent. Preheating duration: 45 minutes at 45 °C.

### 21.3 Wave soldering

Wave soldering is **not** recommended for LQFP packages. This is because of the likelihood of solder bridging due to closely-spaced leads and the possibility of incomplete solder penetration in multi-lead devices.

If wave soldering cannot be avoided, the following conditions must be observed:

- **A double-wave (a turbulent wave with high upward pressure followed by a smooth laminar wave) soldering technique should be used.**
- **The footprint must be at an angle of 45° to the board direction and must incorporate solder thieves downstream and at the side corners.**

**Even with these conditions, do not consider wave soldering LQFP packages LQFP48 (SOT313-2), LQFP64 (SOT314-2) or LQFP80 (SOT315-1).**

During placement and before soldering, the package must be fixed with a droplet of adhesive. The adhesive can be applied by screen printing, pin transfer or syringe dispensing. The package can be soldered after the adhesive is cured.

Maximum permissible solder temperature is 260 °C, and maximum duration of package immersion in solder is 10 seconds, if cooled to less than 150 °C within 6 seconds. Typical dwell time is 4 seconds at 250 °C.

A mildly-activated flux will eliminate the need for removal of corrosive residues in most applications.

### 21.4 Repairing soldered joints

Fix the component by first soldering two diagonally-opposite end leads. Use only a low voltage soldering iron (less than 24 V) applied to the flat part of the lead. Contact time must be limited to 10 seconds at up to 300 °C. When using a dedicated tool, all other leads can be soldered in one operation within 2 to 5 seconds between 270 and 320 °C.

## LCD controller/driver

## PCF2113x

**22 DEFINITIONS**

<b>Data sheet status</b>	
Objective specification	This data sheet contains target or goal specifications for product development.
Preliminary specification	This data sheet contains preliminary data; supplementary data may be published later.
Product specification	This data sheet contains final product specifications.
<b>Limiting values</b>	
Limiting values given are in accordance with the Absolute Maximum Rating System (IEC 134). Stress above one or more of the limiting values may cause permanent damage to the device. These are stress ratings only and operation of the device at these or at any other conditions above those given in the Characteristics sections of the specification is not implied. Exposure to limiting values for extended periods may affect device reliability.	
<b>Application information</b>	
Where application information is given, it is advisory and does not form part of the specification.	

**23 LIFE SUPPORT APPLICATIONS**

These products are not designed for use in life support appliances, devices, or systems where malfunction of these products can reasonably be expected to result in personal injury. Philips customers using or selling these products for use in such applications do so at their own risk and agree to fully indemnify Philips for any damages resulting from such improper use or sale.

**24 PURCHASE OF PHILIPS I<sup>2</sup>C COMPONENTS**

Purchase of Philips I<sup>2</sup>C components conveys a license under the Philips' I<sup>2</sup>C patent to use the components in the I<sup>2</sup>C system provided the system conforms to the I<sup>2</sup>C specification defined by Philips. This specification can be ordered using the code 9398 393 40011.

# Philips Semiconductors – a worldwide company

**Argentina:** see South America

**Australia:** 34 Waterloo Road, NORTH RYDE, NSW 2113,  
Tel. +61 2 9805 4455, Fax. +61 2 9805 4466

**Austria:** Computerstr. 6, A-1101 WIEN, P.O. Box 213,  
Tel. +43 1 60 101, Fax. +43 1 60 101 1210

**Belarus:** Hotel Minsk Business Center, Bld. 3, r. 1211, Volodarski Str. 6,  
220050 MINSK, Tel. +375 172 200 733, Fax. +375 172 200 773

**Belgium:** see The Netherlands

**Brazil:** see South America

**Bulgaria:** Philips Bulgaria Ltd., Energoproject, 15th floor,  
51 James Bourchier Blvd., 1407 SOFIA,  
Tel. +359 2 689 211, Fax. +359 2 689 102

**Canada:** PHILIPS SEMICONDUCTORS/COMPONENTS,  
Tel. +1 800 234 7381

**China/Hong Kong:** 501 Hong Kong Industrial Technology Centre,  
72 Tat Chee Avenue, Kowloon Tong, HONG KONG,  
Tel. +852 2319 7888, Fax. +852 2319 7700

**Colombia:** see South America

**Czech Republic:** see Austria

**Denmark:** Prags Boulevard 80, PB 1919, DK-2300 COPENHAGEN S,  
Tel. +45 32 88 2636, Fax. +45 31 57 1949

**Finland:** Sinikalliontie 3, FIN-02630 ESPOO,  
Tel. +358 9 615800, Fax. +358 9 61580/xxx

**France:** 4 Rue du Port-aux-Vins, BP317, 92156 SURESNES Cedex,  
Tel. +33 1 40 99 6161, Fax. +33 1 40 99 6427

**Germany:** Hammerbrookstraße 69, D-20097 HAMBURG,  
Tel. +49 40 23 53 60, Fax. +49 40 23 536 300

**Greece:** No. 15, 25th March Street, GR 17778 TAVROS/ATHENS,  
Tel. +30 1 4894 339/239, Fax. +30 1 4814 240

**Hungary:** see Austria

**India:** Philips INDIA Ltd, Shivsagar Estate, A Block, Dr. Annie Besant Rd.  
Worli, MUMBAI 400 018, Tel. +91 22 4938 541, Fax. +91 22 4938 722

**Indonesia:** see Singapore

**Ireland:** Newstead, Clonskeagh, DUBLIN 14,  
Tel. +353 1 7640 000, Fax. +353 1 7640 200

**Israel:** RAPAC Electronics, 7 Kehilat Saloniki St, TEL AVIV 61180,  
Tel. +972 3 645 0444, Fax. +972 3 649 1007

**Italy:** PHILIPS SEMICONDUCTORS, Piazza IV Novembre 3,  
20124 MILANO, Tel. +39 2 6752 2531, Fax. +39 2 6752 2557

**Japan:** Philips Bldg 13-37, Kohnan 2-chome, Minato-ku, TOKYO 108,  
Tel. +81 3 3740 5130, Fax. +81 3 3740 5077

**Korea:** Philips House, 260-199 Itaewon-dong, Yongsan-ku, SEOUL,  
Tel. +82 2 709 1412, Fax. +82 2 709 1415

**Malaysia:** No. 76 Jalan Universiti, 46200 PETALING JAYA, SELANGOR,  
Tel. +60 3 750 5214, Fax. +60 3 757 4880

**Mexico:** 5900 Gateway East, Suite 200, EL PASO, TEXAS 79905,  
Tel. +9-5 800 234 7381

**Middle East:** see Italy

**Netherlands:** Postbus 90050, 5600 PB EINDHOVEN, Bldg. VB,  
Tel. +31 40 27 82785, Fax. +31 40 27 88399

**New Zealand:** 2 Wagener Place, C.P.O. Box 1041, AUCKLAND,  
Tel. +64 9 849 4160, Fax. +64 9 849 7811

**Norway:** Box 1, Manglerud 0612, OSLO,  
Tel. +47 22 74 8000, Fax. +47 22 74 8341

**Philippines:** Philips Semiconductors Philippines Inc.,  
106 Valero St. Salcedo Village, P.O. Box 2108 MCC, MAKATI,  
Metro MANILA, Tel. +63 2 816 6380, Fax. +63 2 817 3474

**Poland:** Ul. Lukiska 10, PL 04-123 WARSZAWA,  
Tel. +48 22 612 2831, Fax. +48 22 612 2327

**Portugal:** see Spain

**Romania:** see Italy

**Russia:** Philips Russia, Ul. Usatcheva 35A, 119048 MOSCOW,  
Tel. +7 095 755 6918, Fax. +7 095 755 6919

**Singapore:** Lorong 1, Toa Payoh, SINGAPORE 1231,  
Tel. +65 350 2538, Fax. +65 251 6500

**Slovakia:** see Austria

**Slovenia:** see Italy

**South Africa:** S.A. PHILIPS Pty Ltd., 195-215 Main Road Martindale,  
2092 JOHANNESBURG, P.O. Box 7430 Johannesburg 2000,  
Tel. +27 11 470 5911, Fax. +27 11 470 5494

**South America:** Rua do Rocio 220, 5th floor, Suite 51,  
04552-903 São Paulo, SÃO PAULO - SP, Brazil,  
Tel. +55 11 821 2333, Fax. +55 11 829 1849

**Spain:** Balmes 22, 08007 BARCELONA,  
Tel. +34 3 301 6312, Fax. +34 3 301 4107

**Sweden:** Kottbygatan 7, Akalla, S-16485 STOCKHOLM,  
Tel. +46 8 632 2000, Fax. +46 8 632 2745

**Switzerland:** Allmendstrasse 140, CH-8027 ZÜRICH,  
Tel. +41 1 488 2686, Fax. +41 1 481 7730

**Taiwan:** Philips Semiconductors, 6F, No. 96, Chien Kuo N. Rd., Sec. 1,  
TAIPEI, Taiwan Tel. +886 2 2134 2870, Fax. +886 2 2134 2874

**Thailand:** PHILIPS ELECTRONICS (THAILAND) Ltd.,  
209/2 Sanpavuth-Bangna Road Prakanong, BANGKOK 10260,  
Tel. +66 2 745 4090, Fax. +66 2 398 0793

**Turkey:** Talatpasa Cad. No. 5, 80640 GÜLTEPE/ISTANBUL,  
Tel. +90 212 279 2770, Fax. +90 212 282 6707

**Ukraine:** PHILIPS UKRAINE, 4 Patrice Lumumba str., Building B, Floor 7,  
252042 KIEV, Tel. +380 44 264 2776, Fax. +380 44 268 0461

**United Kingdom:** Philips Semiconductors Ltd., 276 Bath Road, Hayes,  
MIDDLESEX UB3 5BX, Tel. +44 181 730 5000, Fax. +44 181 754 8421

**United States:** 811 East Arques Avenue, SUNNYVALE, CA 94088-3409,  
Tel. +1 800 234 7381

**Uruguay:** see South America

**Vietnam:** see Singapore

**Yugoslavia:** PHILIPS, Trg N. Pasica 5/v, 11000 BEOGRAD,  
Tel. +381 11 625 344, Fax. +381 11 635 777

**For all other countries apply to:** Philips Semiconductors, Marketing & Sales Communications,  
Building BE-p, P.O. Box 218, 5600 MD EINDHOVEN, The Netherlands, Fax. +31 40 27 24825

**Internet:** <http://www.semiconductors.philips.com>

© Philips Electronics N.V. 1997

SCA53

All rights are reserved. Reproduction in whole or in part is prohibited without the prior written consent of the copyright owner.

The information presented in this document does not form part of any quotation or contract, is believed to be accurate and reliable and may be changed without notice. No liability will be accepted by the publisher for any consequence of its use. Publication thereof does not convey nor imply any license under patent- or other industrial or intellectual property rights.

Printed in The Netherlands

417067/00/02/pp60

Date of release: 1997 Apr 04

Document order number: 9397 750 01753

*Let's make things better.*

**Philips**  
Semiconductors



**PHILIPS**