

LINEAR IC

1 CHANNEL 8-BIT D/A
CONVERTER

MB4072

1 CHANNEL 8-BIT D/A CONVERTER

The Fujitsu MB4072 is a High-Speed Digital to Analog Converter IC. The MB4072's current outputs are high impedance open-collector, which provide voltage output with a load or current to voltage converter for various applications with operational amplifiers, microcomputers, etc.

Threshold level of digital inputs is variable with the level control input for various interface level.

- Settling Time : 85ns
- Linearity Error : $\pm 0.19\%$ max.
- Full-scale Temperature coefficient: $\pm 10\text{ppm}/^\circ\text{C}$ typ.
- Output Voltage Compliance : -10V to +18V
- Multiplying Operation
- True/Complimentary Current Sink Output
- Adjustable Threshold Level of Digital Inputs :Interface directly with TTL, CMOS, ECL, etc.
- Wide Supply Voltage Range : $\pm 4.5\text{V}$ to $\pm 18\text{V}$
- Low Power Consumption : 33mW at $\pm 5\text{V}$ typ.
- Operation Temperature : -40°C to $+85^\circ\text{C}$
- Compatible with DAC-08
- Package : Plastic DIP Package: (Suffix: -P)
Plastic FPT Package: (Suffix: -PF)

■ ABSOLUTE MAXIMUM RATINGS

(TA = 25°C)

Parameter	Symbol	Value	Unit
Supply Voltage	V+ to V-	37	V
Digital Input Voltage	VI	V- to V- +37	V
Threshold Control Voltage	VLC	V- to V+	V
Reference Input Voltage	VREF(+)	V- to V+	V
	VREF(-)	V- to V+	V
Differential Reference Input Voltage	VREF(+) to VREF(-)	± 18.5	V
Reference Input Current	IREF	5	mA
Power Consumption	PD	500	mW
Storage Temp.	TSTG	-55 to +125	°C

NOTE: Permanent device damage may occur if the above **Absolute Maximum Ratings** are exceeded. Functional operation should be restricted to the conditions as detailed in the operational sections of this data sheet. Exposure to absolute maximum rating conditions for extended periods may affect device reliability.

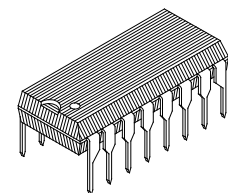
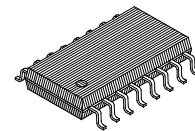
PLASTIC PACKAGE
DIP-16P-M04PLASTIC PACKAGE
FPT-16P-M06

PIN ASSIGNMENT

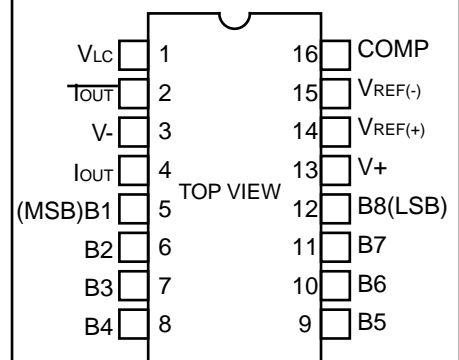

This device contains circuitry to protect the inputs against damage due to high static voltages or electric fields. However, it is advised that normal precautions be taken to avoid application of any voltage higher than maximum rated voltages to this high impedance circuit.

MB4072

Fig. 1 - BLOCK DIAGRAM

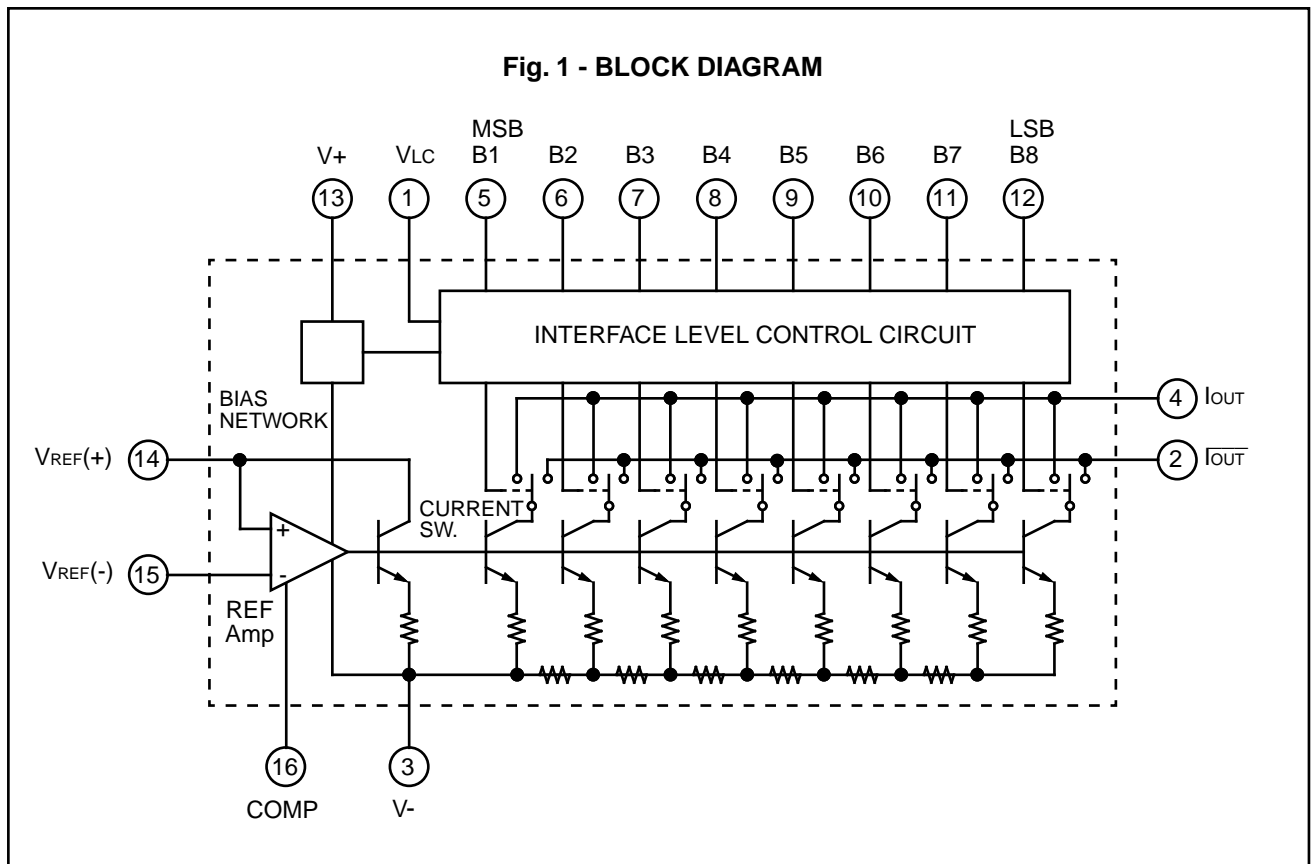

RECOMMENDED OPERATING CONDITIONS

Parameter	Symbol				Unit
		Min	Typ	Max	
Supply Voltage	V+	+4.5	-	+18	V
	V-	-18	-	-4.5	V
Operating Temperature	T _A	-40	-	+85	°C

■ ELECTRICAL CHARACTERISTICS

(Recommended Operating Conditions unless otherwise noted.)

($V_+ = +15V$, $V_- = -15V$, $I_{REF} = 2.0mA$, $T_A = -40^{\circ}C$ to $+85^{\circ}C$)

Parameter	Symbol	Value			Unit
		Min	Typ	Max	
Resolution		8	8	8	bits
Monotonicity		8	8	8	bits
Linearity Error	LE	-	-	± 0.19	% (FSR)
Settling Time (Final Value: $\pm 1/2$ LSB, $T_A = 25^{\circ}C$, On/Off Switching for Each bit/All bits)	t_s	-	85	150	ns
Propagation Delay Time ($T_A = 25^{\circ}C$, On/Off Switching for Each bit/All bits)	t_{PLH} t_{PHL}	-	35	60	ns
Temperature coefficient at full-scale	TC_{IFS}	-	± 10	± 50	ppm/ $^{\circ}C$
Output Voltage Range ($\Delta I_{FS} 1/2$ LSB, $R_{OUT} 20M\Omega$ typ.)	V_{OC}	-10	-	+18	V
Output Current at full-scale ($V_{REF} = 10.000V$, $R_{14} = 5.000k\Omega$, $R_{15} = 5.000k\Omega$, $T_A = 25^{\circ}C$)	I_{FS4}	1.94	1.99	2.04	mA
Symmetry at full-scale ($I_{FSS} = I_{FS4} - I_{FS2}$)	T_{FSS}	-	± 1.0	± 8.0	μA
Output Current at zero scale	I_{ZS}	-	0.2	2.0	μA
Output Current Range ($R_{14} = 5.000k\Omega$, $R_{15} = 5.000k\Omega$, $V_{REF} = +15.0V$, $V_- = -10V$)	I_{OR1}	2.1	-	-	mA
Output Current Range ($R_{14} = 5.000k\Omega$, $R_{15} = 5.000k\Omega$, $V_{REF} = +25.0V$, $V_- = -12V$)	I_{OR2}	4.2	-	-	mA
Low-level Input Voltage ($V_{LC} = 0V$)	V_{IL}	-	-	0.8	V
High-level Input Voltage ($V_{LC} = 0V$)	V_{IH}	2.0	-	-	V
Low-level Input Current ($V_{LC} = 0V$, $V_{IN} = -10V$ to $+0.8V$)	I_{IL}	-	-0.2	-10	μA
High-level Input Current ($V_{LC} = 0V$, $V_{IN} = 2.0V$ to $18V$)	I_{IH}	-	0.002	10	μA

MB4072

■ ELECTRICAL CHARACTERISTICS (Continued)

(VS=±15V, IREF = 2.0mA, TA = -40°C to +85°C)

Parameter		Symbol	Value			Unit
			Min	Typ	Max	
Logic Input Voltage Range (V=-15V)		VIS	-10	-	+18	V
Logic Threshold Voltage Range (V+=+15V, V=-15V)		VTHR	-10	-	+13.5	V
Reference Bias Current		I15	-	-1.0	-3.0	μA
Reference Input Through Rate (REQ=200Ω, RL=100Ω, CL=0pF)		$\frac{dI}{dt}$	4.0	8.0	-	mA/μs
Supply Voltage Sensitivity* (V+=+4.5V to +18V, IREF=1mA)		PSSI _{FS+}	-	±0.0003	±0.01	%/%
Supply Voltage Sensitivity* (V=-4.5V to -18V, IREF=1mA)		PSSI _{FS-}	-	±0.002	±0.01	%/%
Supply Current	(V+=+5V, V=-5V, IREF=1.0mA)	I-	-	2.3	3.8	mA
		I-	-	-4.3	-5.8	mA
	(V+=+5V, V=-15V, IREF=2.0mA)	I-	-	2.4	3.8	mA
		I-	-	-6.4	-7.8	mA
	(V+=+15V, V=-15V, IREF=2.0mA)	I-	-	2.5	3.8	mA
		I-	-	-6.5	-7.8	mA
Power Dissipation	(V+=+5V, V=-5V, IREF=1.0mA)	PD	-	33	48	mW
	(V+=+5V, V=-15V, IREF=2.0mA)	PD	-	103	136	mW
	(V+=+15V, V=-15V, IREF=2.0mA)	PD	-	135	174	mW

*Note: $PSSI_{FS} = \left(\frac{\Delta I_{FS}}{I_{FS}} \times 100 \right) / \left(\frac{18-4.5}{15} \times 100 \right)$

Fig. 2 - WAVEFORM SYNTHESIZER

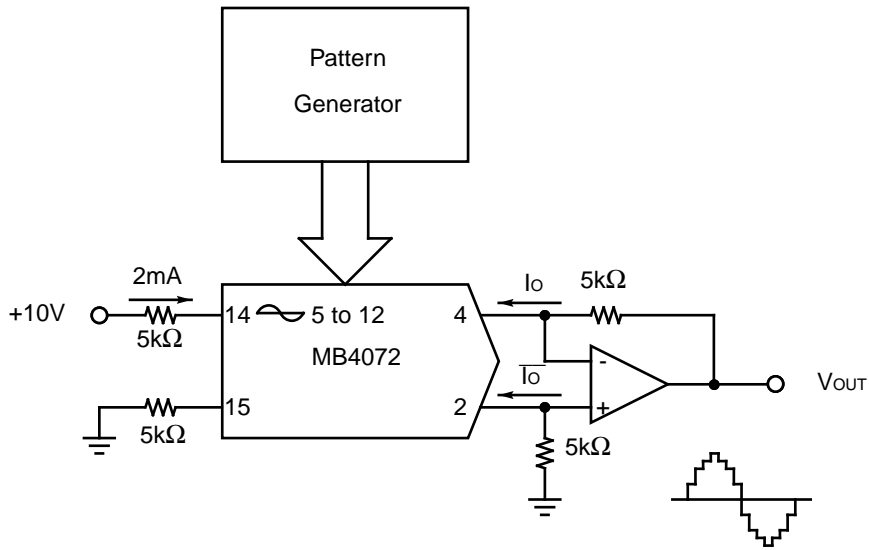

MB4072

■ PACKAGE DIMENSIONS

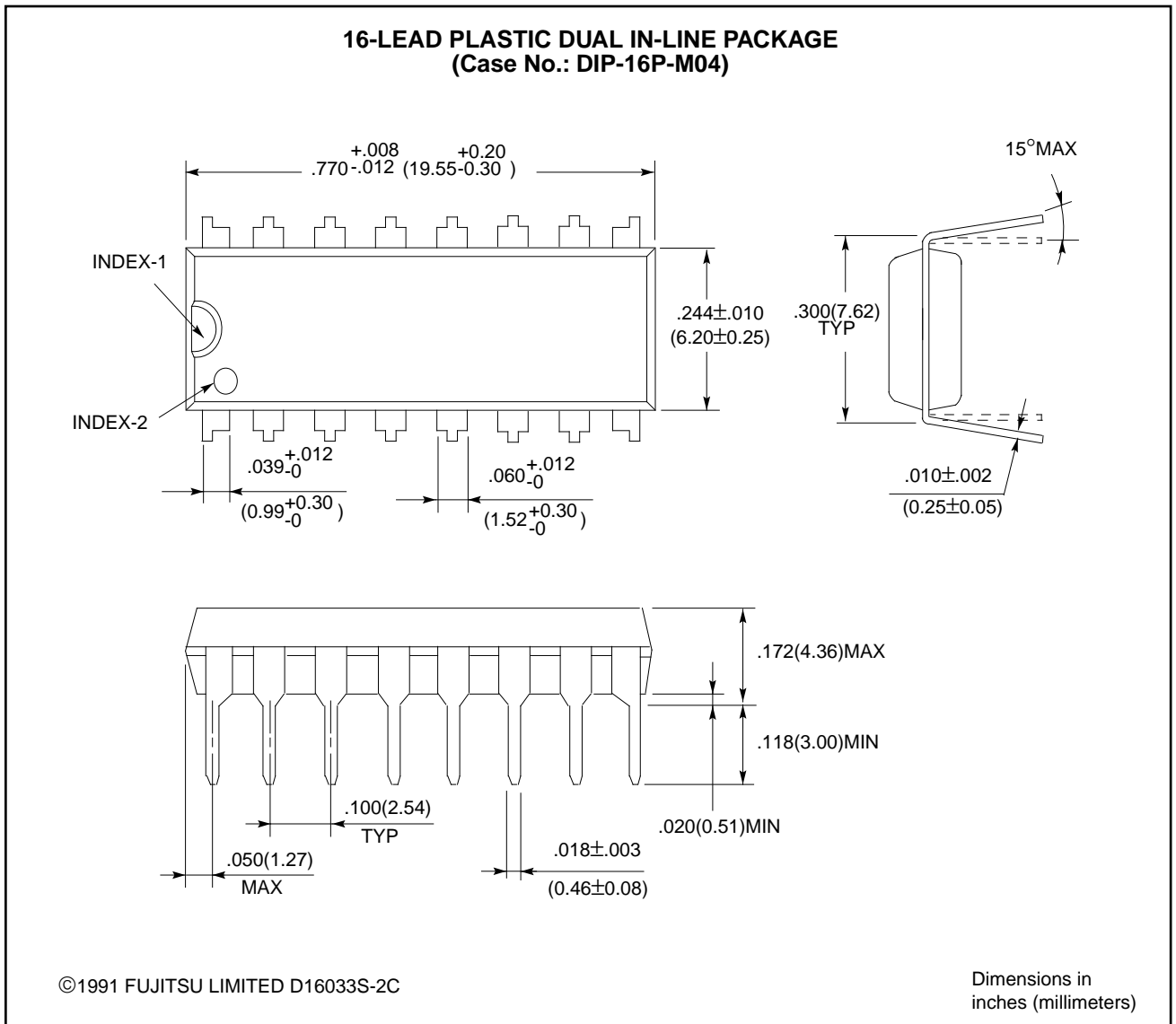

■ PACKAGE DIMENSIONS (Continued)

16-LEAD PLASTIC FLAT PACKAGE
(Case No.: FPT-16P-M06)

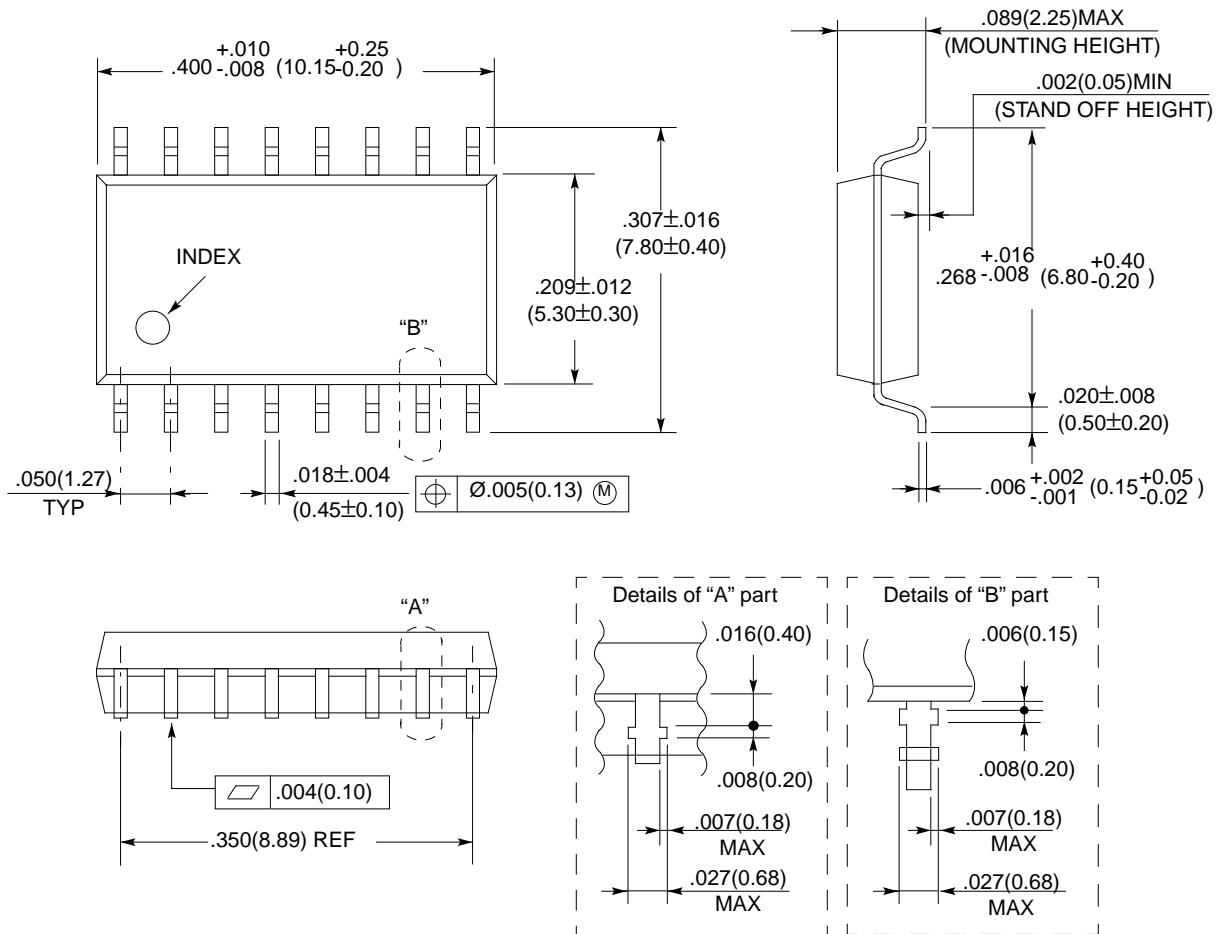

©1991 FUJITSU LIMITED F16015S-2C

Dimensions in inches (millimeters)

FUJITSU LIMITED

For further information please contact:

Japan

FUJITSU LIMITED
Corporate Global Business Support Division
Electronic Devices
KAWASAKI PLANT, 1015, Kamikodanaka
Nakahara-ku, Kawasaki-shi
Kanagawa 211, Japan
Tel: (044) 754-3753
Fax: (044) 754-3329

North and South America

FUJITSU MICROELECTRONICS, INC.
Semiconductor Division
3545 North First Street
San Jose, CA 95134-1804, U.S.A.
Tel: (408) 922-9000
Fax: (408) 432-9044/9045

Europe

FUJITSU MIKROELEKTRONIK GmbH
Am Siebenstein 6-10
63303 Dreieich-Buchsschlag
Germany
Tel: (06103) 690-0
Fax: (06103) 690-122

Asia Pacific

FUJITSU MICROELECTRONICS ASIA PTE. LIMITED
No. 51 Bras Basah Road,
Plaza By The Park,
#06-04 to #06-07
Singapore 189554
Tel: 336-1600
Fax: 336-1609

F9601

© FUJITSU LIMITED Printed in Japan

All Rights Reserved.

Circuit diagrams utilizing Fujitsu products are included as a means of illustrating typical semiconductor applications. Complete information sufficient for construction purposes is not necessarily given.

The information contained in this document has been carefully checked and is believed to be reliable. However, Fujitsu assumes no responsibility for inaccuracies.

The information contained in this document does not convey any license under the copyrights, patent rights or trademarks claimed and owned by Fujitsu.

Fujitsu reserves the right to change products or specifications without notice.

No part of this publication may be copied or reproduced in any form or by any means, or transferred to any third party without prior written consent of Fujitsu.

The information contained in this document are not intended for use with equipments which require extremely high reliability such as aerospace equipments, undersea repeaters, nuclear control systems or medical equipments for life support.