

**LA5633****Satellite Broadcast (BS/CS) Tuner Regulator IC****Overview**

The LA5633 is a low-saturation regulator IC designed for use in satellite broadcast tuners (such as tuners for the Japanese BS and CS systems) and provides four controllable outputs.

Applications

- Power supply systems in BS/CS tuners
- Audio Video (AV) equipment that includes any type of satellite broadcast tuner
- Miniature electronic equipment

Functions

- Built-in four regulators of low-saturation output (15.7 V/350 mA, 9 V/250 mA, 12 V/100 mA, 5 V/650 mA)
- Output on/off control (active low)
- On-chip thermal protection and overcurrent protection circuits

Features

- Provides all four voltages required by BS/CS tuners, and thus can contribute to end product miniaturization.
- V_{O1} can be controlled independently, and V_{O2} , V_{O3} , and V_{O4} are controlled together, thus providing a high degree of flexibility in system design.
- The adoption of a low-saturation regulator circuit reduces internal power dissipation.
- Provides 3 inputs to make both low-power design and thermal design easy.

Package Dimensions

unit: mm

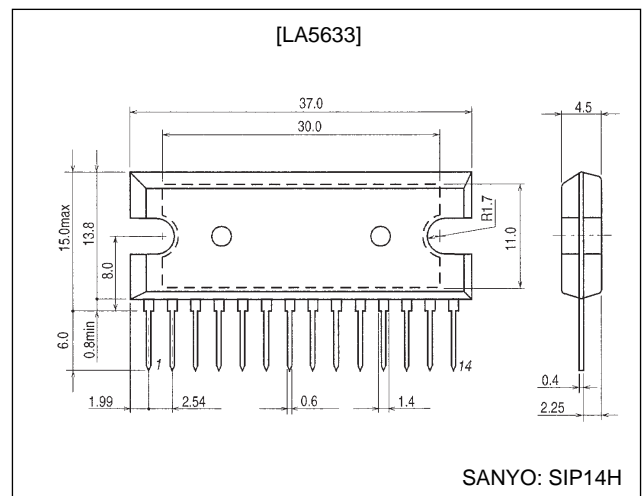
3023A-SIP14H

■ Any and all SANYO products described or contained herein do not have specifications that can handle applications that require extremely high levels of reliability, such as life-support systems, aircraft's control systems, or other applications whose failure can be reasonably expected to result in serious physical and/or material damage. Consult with your SANYO representative nearest you before using any SANYO products described or contained herein in such applications.

■ SANYO assumes no responsibility for equipment failures that result from using products at values that exceed, even momentarily, rated values (such as maximum ratings, operating condition ranges, or other parameters) listed in products specifications of any and all SANYO products described or contained herein.

SANYO Electric Co.,Ltd. Semiconductor Business Headquarters

TOKYO OFFICE Tokyo Bldg., 1-10, 1 Chome, Ueno, Taito-ku, TOKYO, 110-8534 JAPAN

Specifications

Maximum Ratings at Ta = 25°C

| Parameter | Symbol | Conditions | Ratings | Unit |
|---|---------------------|--|---------------------|------|
| Input voltage | V _{IN} max | V _{IN1} ≥ V _{IN2} ≥ V _{IN3} | 35 | V |
| Enable pin voltage | V _{EN} max | EN1, EN2 | V _{IN} max | V |
| Allowable power dissipation | Pd max | With an arbitrarily large heat sink | 15 | W |
| | | With no heat sink | 4.3 | W |
| Junction to case thermal resistance | θ _{j-c} | | 3 | °C/W |
| Junction to atmosphere thermal resistance | θ _{j-a} | | 29.07 | °C/W |
| Operating temperature | T _{opr} | | -20 to +80 | °C |
| Storage temperature | T _{stg} | | -55 to +150 | °C |
| Junction temperature | T _j max | | 150 | °C |

Operating Conditions at Ta = 25°C

| Parameter | Symbol | Conditions | Ratings | Unit |
|----------------|-----------------|-------------|----------|------|
| Output current | I _{O1} | Regulator 1 | 5 to 350 | mA |
| | I _{O2} | Regulator 2 | 1 to 250 | mA |
| | I _{O3} | Regulator 3 | 1 to 100 | mA |
| | I _{O4} | Regulator 4 | 5 to 650 | mA |

Operating Characteristics at Ta = 25°C in the stipulated test circuit

| Parameter | Symbol | Conditions | Ratings | | | Unit |
|--|----------------------|--|---------|------|------------------|-------|
| | | | min | typ | max | |
| Regulator 1 [V _{EN1} = low, V _{O1} : on, V _{IN1} = 20 V, V _{IN2} = 11 V, V _{IN3} = 7.0 V, I _{O1} = 350 mA] | | | | | | |
| Output voltage 1 | V _{O1} | | 14.9 | 15.7 | 16.5 | V |
| Dropout voltage | V _{DROP1-1} | | | 0.3 | 0.5 | V |
| | V _{DROP1-2} | I _{O1} = 175 mA | | 0.15 | 0.3 | V |
| Line regulation | ΔV _{OLN1} | 17.5 V ≤ V _{IN1} ≤ 23 V | | 20 | 100 | mV |
| Load regulation | ΔV _{OLD1} | 5 mA ≤ I _{O1} ≤ 350 mA | | 40 | 200 | mV |
| Peak output current | I _{OP1} | | 350 | 540 | | mA |
| Output short-circuit current | I _{OSC1} | | | 150 | | mA |
| Output on control voltage | V _{ENL1} | V _{O1} : ON | | | 1.0 | V |
| Output off control voltage | V _{ENH1} | V _{O1} : OFF | 4.0 | | V _{IN1} | V |
| Output low-level voltage | V _{O1} OFF | | | | 0.2 | V |
| Output noise voltage | V _{NOISE1} | 10 Hz ≤ f ≤ 100 kHz | | 110 | | μVrms |
| Ripple rejection | Rrej1 | f = 120 Hz, 18 V ≤ V _{IN1} ≤ 23 V | | 50 | | dB |
| Regulator 2 [V _{EN2} = low, V _{O2} : on, V _{IN1} = 20 V, V _{IN2} = 11 V, V _{IN3} = 7.0 V, I _{O2} = 250 mA] | | | | | | |
| Output voltage 2 | V _{O2} | | 8.55 | 9.0 | 9.45 | V |
| Dropout voltage | V _{DROP2} | | | 0.3 | 0.5 | V |
| Line regulation | ΔV _{OLN2} | 10.45 V ≤ V _{IN2} ≤ 23 V | | 20 | 100 | mV |
| Load regulation | ΔV _{OLD2} | 1 mA ≤ I _{O2} ≤ 250 mA | | 30 | 100 | mV |
| Peak output current | I _{OP2} | | 250 | 270 | | mA |
| Output short-circuit current | I _{OSC2} | | | 70 | | mA |
| Output on control voltage | V _{ENL2} | V _{O2} : ON | | | 1.0 | V |
| Output off control voltage | V _{ENH2} | V _{O2} : OFF | 4.0 | | V _{IN2} | V |
| Output low-level voltage | V _{O2} OFF | | | | 0.2 | V |
| Output noise voltage | V _{NOISE2} | 10 Hz ≤ f ≤ 100 kHz | | 110 | | μVrms |
| Ripple rejection | Rrej2 | f = 120 Hz, 11 V ≤ V _{IN2} ≤ 23 V | | 50 | | dB |
| Regulator 3 [V _{EN2} = low, V _{O3} on, V _{IN1} = 20 V, V _{IN2} = 11 V, V _{IN3} = 7.0 V, I _{O3} = 100 mA] | | | | | | |
| Output voltage 3 | V _{O3} | | 11.4 | 12.0 | 12.6 | V |
| Dropout voltage | V _{DROP3} | | | 0.3 | 0.5 | V |
| Line regulation | ΔV _{OLN3} | 13.6 V ≤ V _{IN1} ≤ 23 V | | 20 | 100 | mV |
| Load regulation | ΔV _{OLD3} | 1 mA ≤ I _{O3} ≤ 100 mA | | 20 | 50 | mV |
| Peak output current | I _{OP3} | | 100 | 150 | | mA |
| Output short-circuit current | I _{OSC3} | | | 40 | | mA |
| Output on control voltage | V _{ENL2} | V _{O3} : ON | | | 1.0 | V |

Continued on next page.

LA5633

Continued from preceding page.

| Parameter | Symbol | Conditions | Ratings | | | Unit |
|--|----------------------|--|---------|-----|-----------|------------------|
| | | | min | typ | max | |
| Output off control voltage | V_{ENH2} | $V_{O3} : \text{OFF}$ | 4.0 | | V_{IN1} | V |
| Output low-level voltage | $V_{O3 \text{ OFF}}$ | | | | 0.2 | V |
| Output noise voltage | V_{NOISE3} | $10 \text{ Hz} \leq f \leq 100 \text{ kHz}$ | | 70 | | μVrms |
| Ripple rejection | R_{rej3} | $f = 120 \text{ Hz}, 14 \text{ V} \leq V_{IN1} \leq 23 \text{ V}$ | | 55 | | dB |
| Regulator 4 [$V_{EN2} = \text{low}, V_{O4} : \text{on}, V_{IN1} = 20 \text{ V}, V_{IN2} = 11 \text{ V}, V_{IN3} = 7.0 \text{ V}, I_{O4} = 650 \text{ mA}$] | | | | | | |
| Output voltage 4 | V_{O4} | | 4.75 | 5.0 | 5.25 | V |
| Dropout voltage | $V_{DROP4-1}$ | | | 0.3 | 0.5 | V |
| | $V_{DROP4-2}$ | $I_{O1} = 325 \text{ mA}$ | | 0.2 | 0.4 | V |
| Line regulation | ΔV_{OLN4} | $6.25 \text{ V} \leq V_{IN3} \leq 23 \text{ V}$ | | 20 | 100 | mV |
| Load regulation | ΔV_{OLD4} | $5 \text{ mA} \leq I_{O4} \leq 650 \text{ mA}$ | | 30 | 150 | mV |
| Peak output current | I_{OP4} | | 650 | 900 | | mA |
| Output short-circuit current | I_{OSC4} | | | 250 | | mA |
| Output on control voltage | V_{ENL2} | $V_{O4} : \text{ON}$ | | | 1.0 | V |
| Output off control voltage | V_{ENH2} | $V_{O4} : \text{OFF}$ | 4.0 | | V_{IN3} | V |
| Output low-level voltage | $V_{O4 \text{ OFF}}$ | | | | 0.2 | V |
| Output noise voltage | V_{NOISE1} | $10 \text{ Hz} \leq f \leq 100 \text{ kHz}$ | | 70 | | μVrms |
| Ripple rejection | R_{rej4} | $f = 120 \text{ Hz}, 7 \text{ V} \leq V_{IN3} \leq 23 \text{ V}$ | | 60 | | dB |
| Current drain | I_{Q1} | $I_{O1}, I_{O2}, I_{O3}, I_{O4} = 0$ | | 11 | | mA |
| | I_{Q2} | $I_{O1} = 350 \text{ mA}, I_{O2} = 250 \text{ mA}, I_{O3} = 100 \text{ mA}, I_{O4} = 650 \text{ mA}$ | | 65 | | mA |

Pin Assignment

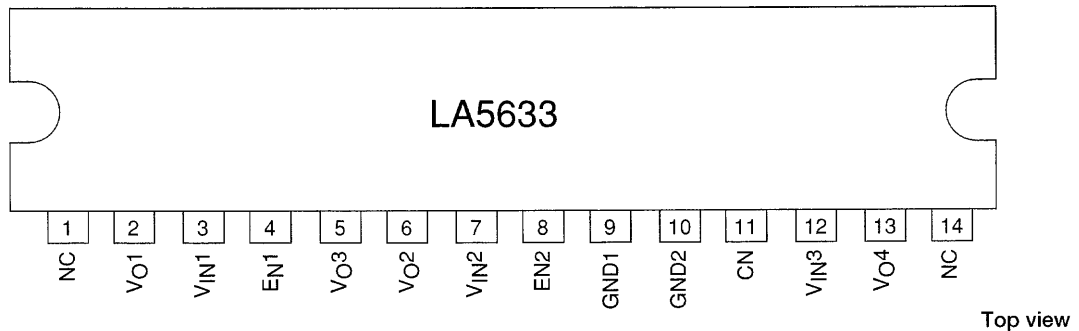

A11067

Note: NC pins must not be used (Pins 1 and 14 in the pin assignment figure.)

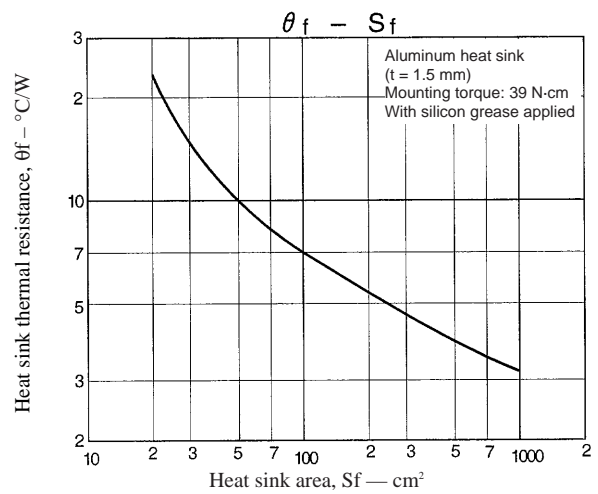
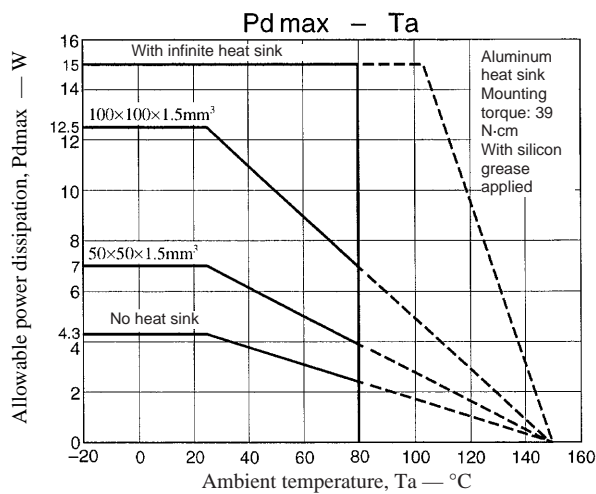

Block Diagram

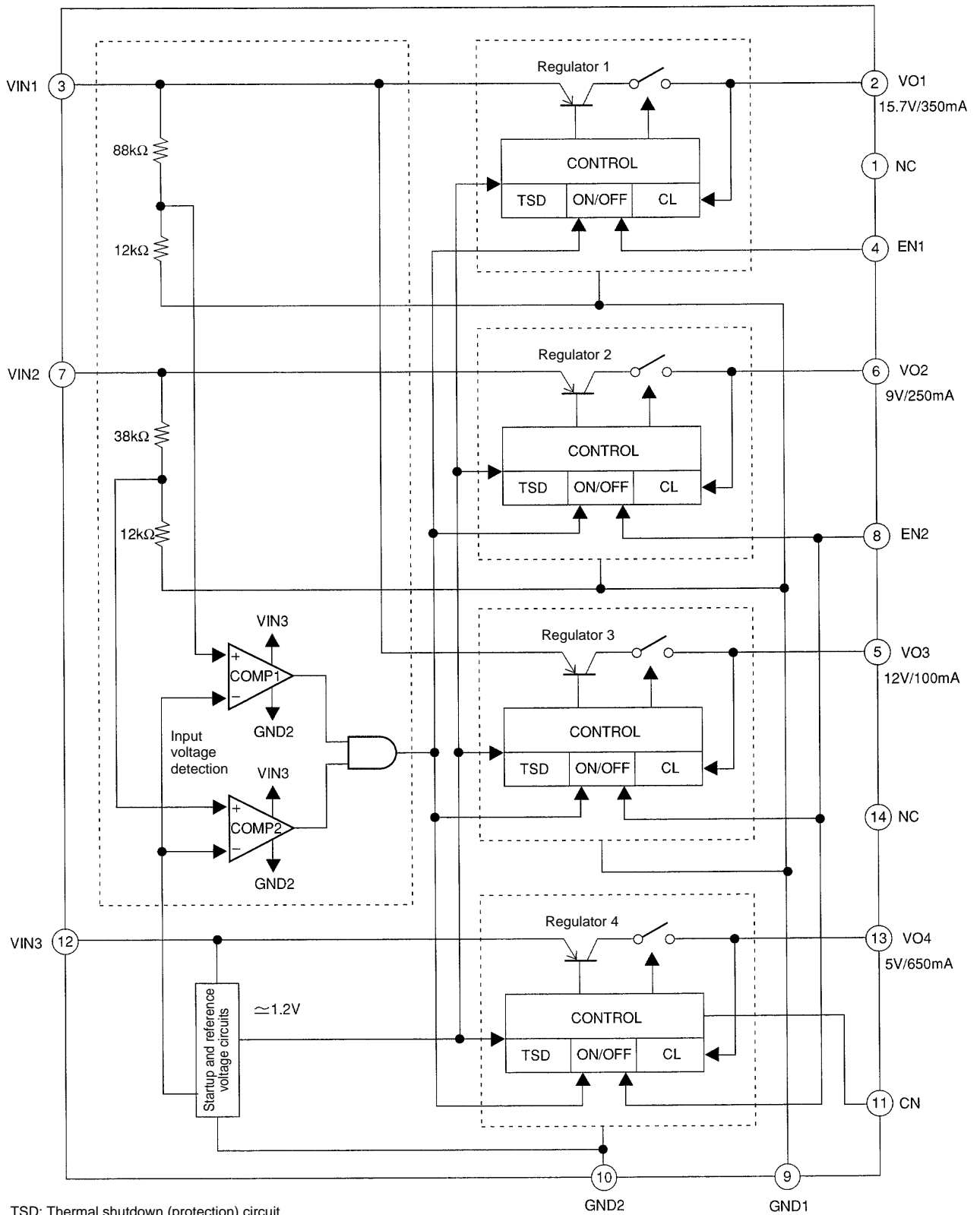

TSD: Thermal shutdown (protection) circuit
 ON/OFF: Output on/off control circuit
 CL: Current limiter (overcurrent protection circuit)

A11068

Stipulated Test Circuit

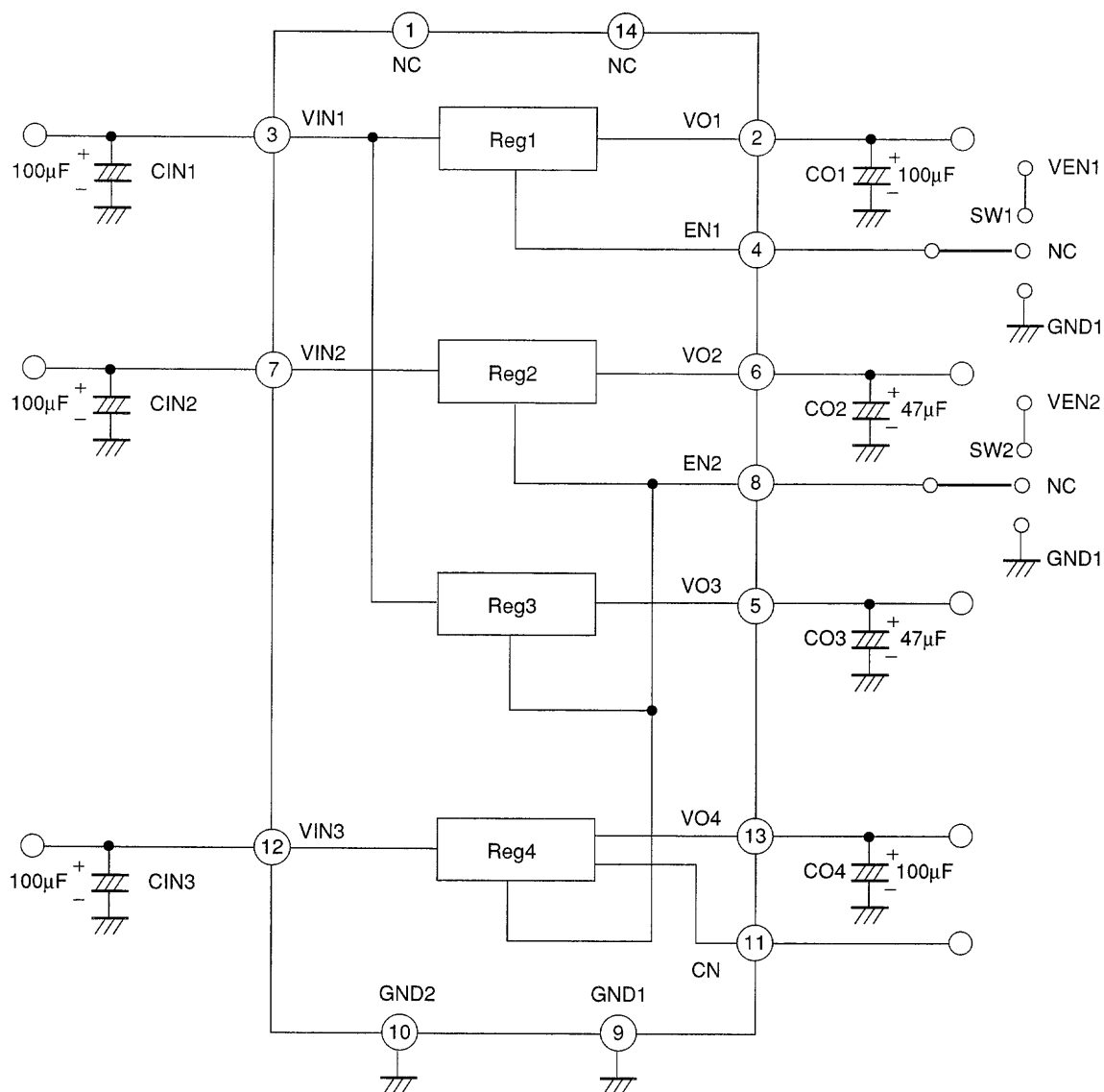

A11069

Function Table

This IC operates as listed in the table under the condition that $V_{IN1} \geq V_{IN2} \geq V_{IN3}$.

| EN1, EN2 | $V_{O1}, V_{O2}/V_{O3}/V_{O4}$ |
|----------|--------------------------------|
| H | L |
| L | H |
| Open | H |

- H and L in the EN column correspond to high and low input voltage levels, respectively.
- H and L in the V_O column correspond to the output on voltage and the output off voltage, respectively.
- The output voltages are controlled independently by the EN lines as follows: EN1 controls V_{O1} , and EN2 controls V_{O2} , V_{O3} , and V_{O4} in parallel.
- When a given EN is open, the corresponding output will be on.

EN (on/off control) Input Block Equivalent Circuit Block Diagram

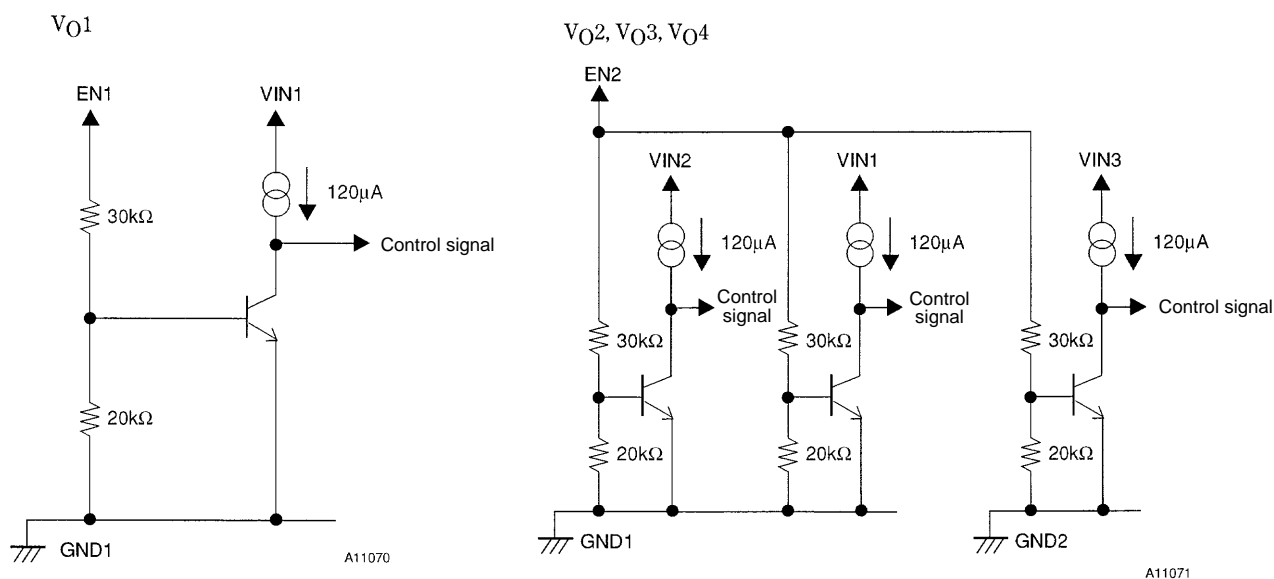

Usage Notes

- GND1 and GND2 are connected through the IC substrate, and must be connected to the lowest potential in the system and must be connected to identical potentials. (The functions and characteristics of this IC are not guaranteed if GND1 and GND2 are connected to different potentials.)
 - The rise and fall of the V_{IN1}, V_{IN2}, and V_{IN3} voltages must be simultaneous, and none of these pins may be either left open or connected to ground.
 - If either V_{IN1} or V_{IN2} are open or at a voltage lower than the stipulated voltage, then the V_{O1} through V_{O4} outputs will be forcibly turned off to protect the IC.
 - The output capacitors C_{O1} and C_{O4} must be at least 100 μF, and C_{O2} and C_{O3} must be at least 47 μF. Capacitors with low temperature coefficients must be use to prevent oscillation at low temperatures.
 - To assure stable operation, the input capacitors C_{IN1} to C_{IN3} and the output capacitors C_{O1} to C_{O4} must be placed as close to the IC as possible.
 - The NC pins (pins 1 and 14) must not be used.
 - The output voltage V_{O4} can be adjusted by connecting resistors from the CN pin (pin 11) to either V_{O4} or to GND2.
 - To lower V_{O4}: Add resistor RA between CN and V_{O4}.
 - To raise V_{O4}: Add resistor RB between CN and GND2.
- Also note that external noise suppression and ripple rejection can be improved by adding an external capacitor at V_{O4}. However, care is required to assure that the system stability (phase margin) is adequate.
- Note that these power supplies can be influenced by load fluctuations in the other power supplies.

Sample CN Pin Application Circuit

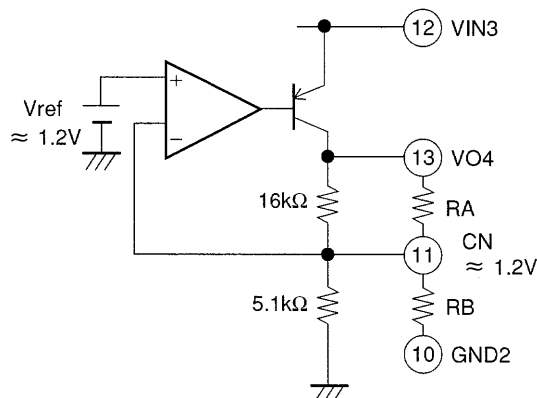

A11072

- Specifications of any and all SANYO products described or contained herein stipulate the performance, characteristics, and functions of the described products in the independent state, and are not guarantees of the performance, characteristics, and functions of the described products as mounted in the customer's products or equipment. To verify symptoms and states that cannot be evaluated in an independent device, the customer should always evaluate and test devices mounted in the customer's products or equipment.
- SANYO Electric Co., Ltd. strives to supply high-quality high-reliability products. However, any and all semiconductor products fail with some probability. It is possible that these probabilistic failures could give rise to accidents or events that could endanger human lives, that could give rise to smoke or fire, or that could cause damage to other property. When designing equipment, adopt safety measures so that these kinds of accidents or events cannot occur. Such measures include but are not limited to protective circuits and error prevention circuits for safe design, redundant design, and structural design.
- In the event that any or all SANYO products (including technical data, services) described or contained herein are controlled under any of applicable local export control laws and regulations, such products must not be exported without obtaining the export license from the authorities concerned in accordance with the above law.
- No part of this publication may be reproduced or transmitted in any form or by any means, electronic or mechanical, including photocopying and recording, or any information storage or retrieval system, or otherwise, without the prior written permission of SANYO Electric Co., Ltd.
- Any and all information described or contained herein are subject to change without notice due to product/technology improvement, etc. When designing equipment, refer to the "Delivery Specification" for the SANYO product that you intend to use.
- Information (including circuit diagrams and circuit parameters) herein is for example only; it is not guaranteed for volume production. SANYO believes information herein is accurate and reliable, but no guarantees are made or implied regarding its use or any infringements of intellectual property rights or other rights of third parties.

This catalog provides information as of October, 1998. Specifications and information herein are subject to change without notice.