



# LA1065M

## 2 Tuner Diversity Circuit for Car FM Tuner

### Overview

The LA1065M is a multi-functional IC for 2 tuner diversity, and is capable of multi-path distortion detection with high sensitivity.

### Functions

- Noise amplifier.
- Noise AGC circuit.
- Noise density comparison counting circuit.
- MAIN/SUB switching output.
- Weak electric field detection and antenna fixing circuit.
- Very strong electric field detection and antenna fixing circuit.
- S meter voltage comparison circuit.
- AGC voltage output.
- S meter switch.

### Package Dimensions

unit: mm

#### 3036B-MFP20

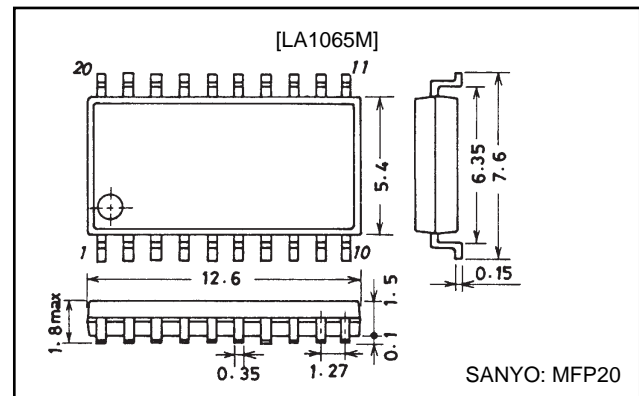

### Specifications

#### Maximum Ratings at Ta=25°C

Parameter	Symbol	Conditions	Ratings	Unit
Maximum supply voltage	$V_{CC \text{ max}}$		13	V
Maximum flow-out current	$I(4)$	Pin 4	1	mA
	$I(5)$	Pin 5	1	mA
	$I(6)$	Pin 6	1	mA
	$I(9)$	Pin 9	10	mA
	$I(12)$	Pin 12	100	$\mu\text{A}$
Maximum flow-in current	$I(7)$	Pin 7	1	mA
	$I(8)$	Pin 8	1	mA
Maximum applied voltage	$V(15)$		$V_{CC}$	V
	$V(16)$		$V_{CC}$	V
	$V(17)$		$V_{CC}$	V
	$V(13)$		$V_{CC}$	V
	$V(14)$		$V_{CC}$	V
Allowable power dissipation	$P_d \text{ max}$	Ta=25°C	230	mW
Operating temperature	Topr		-30 to +80	°C
Storage temperature	Tstg		-40 to +125	°C

# LA1065M

## Operating Conditions at $T_a=25^\circ\text{C}$

Parameter	Symbol	Conditions	Ratings	Unit
Recommended supply voltage	$V_{CC}$		8	V
Operating voltage range	$V_{CC\text{ op}}$		7 to 12	V

## Operation Characteristics at $T_a=25^\circ\text{C}$ , $V_{CC}=8\text{V}$ , $f=100\text{kHz}$ sine wave

Parameter	Symbol	Conditions	Ratings			Unit
			min	typ	max	
Current drain	$I_{CC}$	No input, not including pin 9 current	10	16	22	mA
Pin 9 high-level voltage	$V_{9H}$	$1\text{k}\Omega$ resistance between pin 9 and GND	5.0	6.0	7.5	V
Noise amplifier gain	$G_{\text{sub}}$	$V_{\text{sub in}}=10\text{mVrms}$ pin 6 output	33	36	39	dB
Noise amplifier gain	$G_{V1}$	$V_{\text{main in}}=V_{\text{sub in}}=1\text{mVrms}$ pin 6 output	33	36	39	dB
	$G_{V2}$	$V_{\text{main in}}=V_{\text{sub in}}=100\text{mV}$ pin 6 output	6	10	14	dB
Noise detection sensitivity	NDS	Noise AGC off	8	12	16	mVrms
Noise count number	NCN	Difference between MAIN and SUB noise		4		
Gate time 1	$t_G$	Noise AGC off	500	620	740	$\mu\text{s}$
		Repeat cycle of pin 4 waveform				
Pin 6 voltage	$V_6$	$V_{\text{main}}=V_{\text{sub}}=200\text{mVrms}$	0.4	1.1	2.0	V
Pin 5 voltage	$V_5$	$V_{\text{sub}}=100\text{mVrms}$	2.50	2.85	3.20	V
Strong field detection level	$V_{17}$		0.7	1.1	1.5	V
Medium field detection level	$V_{14}$		2.4	2.7	3.1	V
Weak field detection level	$V_{13}$		1.7	2.1	2.4	V
S meter switch residual	$V_{12}$	Input=0V			130	mVrms

## Equivalent Circuit Block Diagram

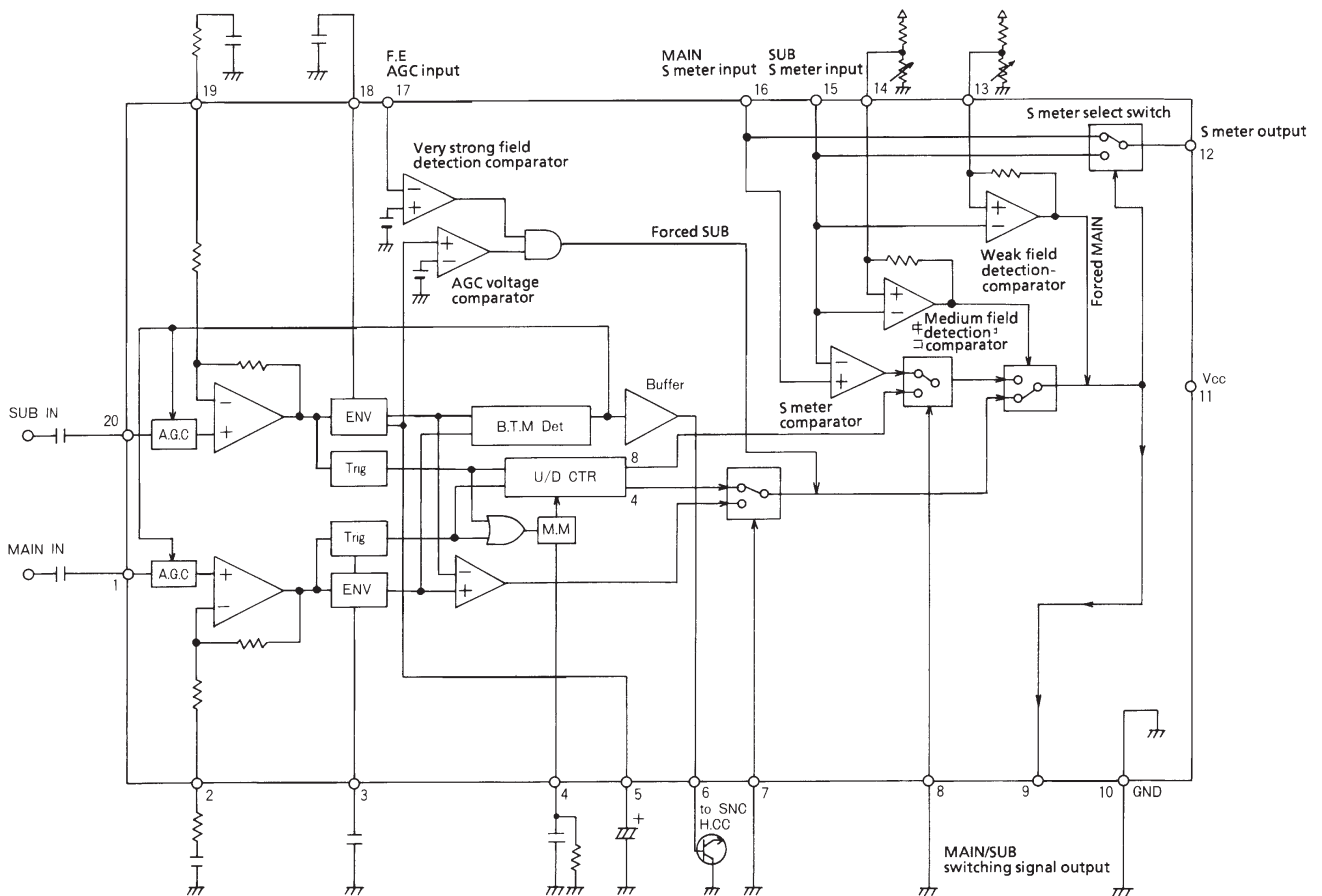

Sample Application Circuit

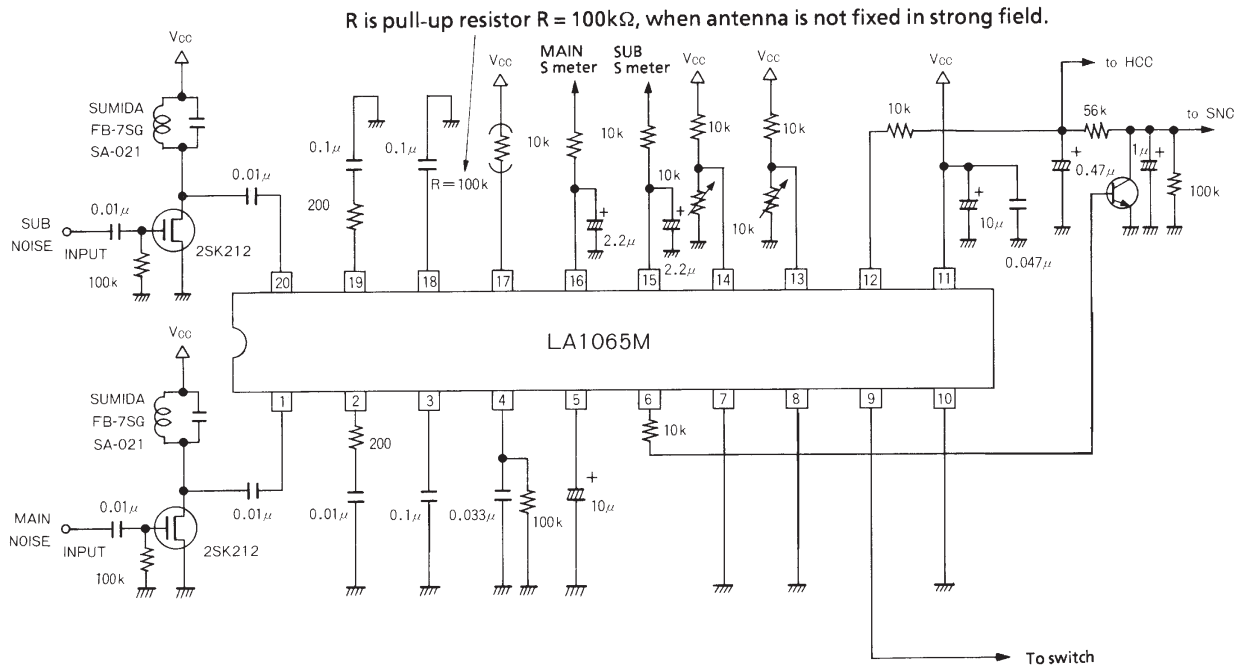

Unit (resistance : Ω, capacitance : F)

Operating Principle

(1) Multi-path distortion detection

• Overview

The LA1065M compares the high frequency noise elements in the S meter output from the two tuners to perform multi-path distortion detection.

In addition to the higher harmonic distortion due to multi-path, the S meter noise includes pulse noise such as car engine ignition noise, distortion elements due to modulation, phase noise and so on. All of this noise causes misoperation of multi-path distortion detection.

The LA1065M resolves this problem through use of a unique noise count comparison method and the bottom detection-type noise AGC.

• Noise count comparison

The causes of misoperation in a diversity reception system, which are pulse noise, distortion elements caused by modulation, and phase noise, exist almost equally for MAIN and SUB. Also, the multi-path distortion to be detected tends to exist on either the MAIN or SUB side.

The LA1065M uses an up/down counter to compare the noise counts of MAIN and SUB and detect multi-path.

• Bottom detection noise AGC

As described above, the S meter noise also exists on both MAIN and SUB sides, so when there is noise on both sides, AGC goes on to prevent misoperation. On the other hand, when multi-path is generated and noise is on one side or the other, AGC does not go on, enabling high sensitivity detection.

• A combination of the above methods is used to make the LA1065M capable of accurate multi-path detection.

## LA1065M

### (2) S meter voltage comparison

For a medium field, the sound may be better if the antenna is switched by comparing S meter DC voltage rather than using multi-path distortion detection when, for example, there is quite a difference (more than 10dB) in antenna sensitivity between MAIN and SUB. On the LA1065M, a built-in comparator detects the medium field, and compares S meter DC voltage in order to switch the antenna.

### (3) Weak field detection and antenna fixing (MAIN)

There is a difference in antenna sensitivity between MAIN and SUB in a weak field, so sensitivity will be insufficient even if switched to SUB.

The LA1065M uses a comparator, as shown below, to detect the weak field and fix the switching signal to the MAIN side.

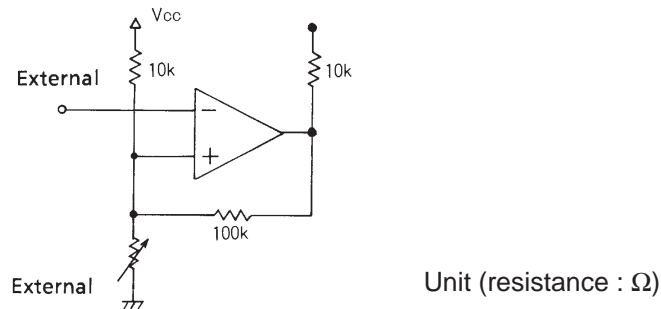

### (4) Very strong field detection and antenna fixing (SUB)

Interference such as I.M. (intermodulation) and cross modulation is generated in a very strong field. One countermeasure is to use a PIN diode for antenna damping, but here the lower antenna gain on the SUB side is utilized to fix the antenna to the SUB side when the electric field is strong. Also, with LA1065M, operation returns to normal when multi-path is generated.

### (5) AGC voltage output

As described in the section on bottom detection-type noise AGC, AGC voltage goes high when there is a lot of noise on both MAIN and SUB sides. This voltage can be used to apply SNC, HCC and so on when the conditions are poor for both MAIN and SUB.

### (6) S meter switch

The LA1065M has built-in S meter switch so that SNC can be applied according to the MAIN and SUB switching output. When the antenna is on MAIN, SNC is applied by MAIN side S meter voltage, and when it is on SUB, by SUB side meter voltage.

### (7) Logic section

The LA1065M operation is shown in the table below.

MAIN multi-path detection	SUB multi-path detection	MAIN S meter voltage	SUB S meter voltage	FE AGC voltage	MAIN/SUB switching output
With noise	No noise	*	Strong field	Weak-medium field	SUB side
No noise	With noise	*	Strong field	Weak-medium field	MAIN side
*	*	*	Weak field	*	MAIN side
*	*	MAIN>SUB	Medium field	Weak-medium field	MAIN side
*	*	MAIN<SUB	Medium field	Weak-medium field	SUB side
*	No noise	*	Strong field	Very strong field	SUB side
No noise	With noise	*	Strong field	Very strong field	MAIN side
Large noise	Medium noise	*	Strong field	Very strong field	SUB side
Small noise	Medium noise	*	Strong field	Very strong field	MAIN side

\* : Under any conditions

# LA1065M

## Pin Function

Unit (resistance :  $\Omega$ , capacitance : F)

Pin No.	Function	External	Notes
1 (20)	MAIN IN SUB IN	<p>The AC component of 114kHz in IF, S meter output is taken by the BPF and input to pin 1 (or pin 20) by C coupling.</p> <p style="text-align: center;">[114kHz B.P.F.]</p>	Be advised that the LA1065M input impedance changes with input and can go to a minimum of 10k $\Omega$ .
2 (19)	H.P.F.		Highpass filter
3 (18)	AGC		Increase this capacitor's value if antenna switching tends to misoperate.
4	Monostable multi-vibrator	<p style="text-align: right;">Count gate time changes according to this time constant.</p>	

Continued on next page.

# LA1065M

Continued from preceding page.

Unit (resistance :  $\Omega$ , capacitance : F)

Pin No.	Function	External	Notes									
5	SUB noise detection for strong field											
6	AGC voltage output		DC voltage corresponding to the LA1065M AGC can be taken.									
7 8	Multi-path detection mode switching	<p style="text-align: center;"><b>Mode switching table</b></p> <table border="1" style="margin-left: auto; margin-right: auto; border-collapse: collapse;"> <thead> <tr> <th style="width: 10%;">Pin No.</th> <th style="width: 40%;">GND</th> <th style="width: 50%;">V<sub>CC</sub></th> </tr> </thead> <tbody> <tr> <td style="text-align: center;">Pin 7</td> <td>Count method for strong field (4 counts)</td> <td>S meter 114kHz level comparison for strong field</td> </tr> <tr> <td style="text-align: center;">Pin 8</td> <td>S meter comparison for medium field</td> <td>Count method for medium field (8 counts)</td> </tr> </tbody> </table>	Pin No.	GND	V <sub>CC</sub>	Pin 7	Count method for strong field (4 counts)	S meter 114kHz level comparison for strong field	Pin 8	S meter comparison for medium field	Count method for medium field (8 counts)	
Pin No.	GND	V <sub>CC</sub>										
Pin 7	Count method for strong field (4 counts)	S meter 114kHz level comparison for strong field										
Pin 8	S meter comparison for medium field	Count method for medium field (8 counts)										
9	MAIN/SUB switching signal output		MAIN is high (6V typ when resistance between pin 9 and GND is 1k $\Omega$ ) and SUB is low.									

Continued on next page.

# LA1065M

Continued from preceding page.

Unit (resistance :  $\Omega$ , capacitance : F)

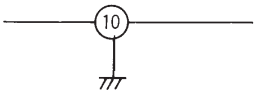
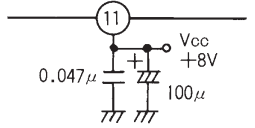
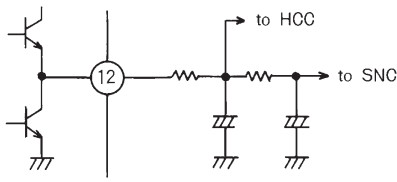
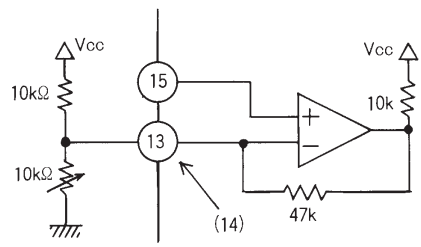
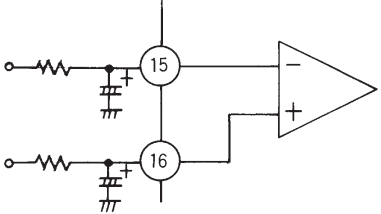
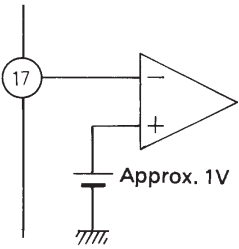
Pin No.	Function	External	Notes
10	GND		
11	VCC		
12	S meter output		
13	Comparator for weak field detection		
14	Comparator for medium field detection		
15	SUB S meter input		S meter input must be sufficiently integrated before input.
16	MAIN S meter input		
17	F.E. AGC input		Comparison level is set at approximately 1V.

- No products described or contained herein are intended for use in surgical implants, life-support systems, aerospace equipment, nuclear power control systems, vehicles, disaster/crime-prevention equipment and the like, the failure of which may directly or indirectly cause injury, death or property loss.
- Anyone purchasing any products described or contained herein for an above-mentioned use shall:
  - ① Accept full responsibility and indemnify and defend SANYO ELECTRIC CO., LTD., its affiliates, subsidiaries and distributors and all their officers and employees, jointly and severally, against any and all claims and litigation and all damages, cost and expenses associated with such use:
  - ② Not impose any responsibility for any fault or negligence which may be cited in any such claim or litigation on SANYO ELECTRIC CO., LTD., its affiliates, subsidiaries and distributors or any of their officers and employees jointly or severally.
- Information (including circuit diagrams and circuit parameters) herein is for example only; it is not guaranteed for volume production. SANYO believes information herein is accurate and reliable, but no guarantees are made or implied regarding its use or any infringements of intellectual property rights or other rights of third parties.

This catalog provides information as of September, 1997. Specifications and information herein are subject to change without notice.