

DATA SHEET

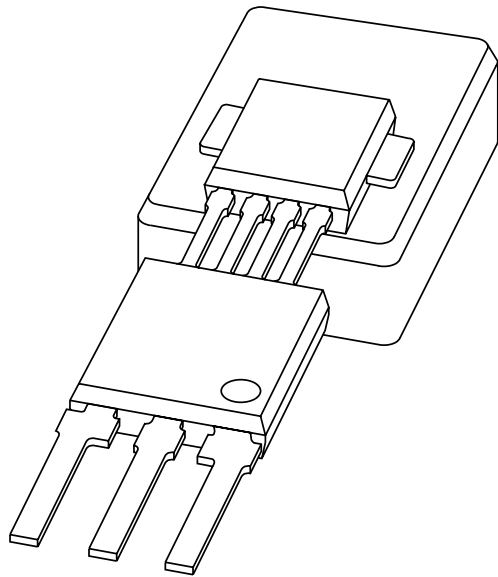

KMI16/1

Integrated rotational speed sensor

Preliminary specification
File under Discrete Semiconductors, SC17

1998 May 15

Integrated rotational speed sensor

KMI16/1

FEATURES

- Open collector output signal
- Zero speed capability
- Wide air gap
- Wide temperature range
- Insensitive to vibration
- EMC resistant.

DESCRIPTION

The KMI16/1 sensor detects rotational speed of ferrous gear wheels and reference marks. The sensor consists of a magnetoresistive sensor element, a signal conditioning integrated circuit in bipolar technology and a magnetized ferrite magnet. The frequency of the digital current output signal is proportional to the rotational speed of a gear wheel.

CAUTION
Do not press two or more products together against their magnetic forces.

PINNING

PIN	DESCRIPTION
1	V _{CC}
2	V _{out}
3	GND

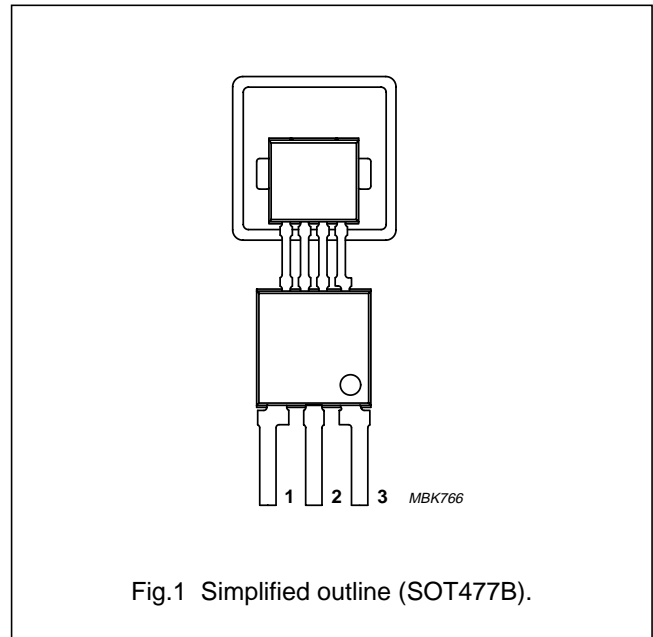

QUICK REFERENCE DATA

SYMBOL	PARAMETER	CONDITIONS	MIN.	TYP.	MAX.	UNIT
V _{CC}	DC supply voltage		4.5	12	16.5	V
V _{out (low)}	remaining open collector voltage		–	–	0.5	V
I _{CC}	DC supply current		6.5	10	12	mA
d _{max}	maximum sensing distance	target wheel m = 2 mm	–	2	–	mm
f _t	operating tooth frequency		0	–	25000	Hz
T _{amb}	ambient operating temperature		–40	–	+150	°C

Integrated rotational speed sensor

KMI16/1

LIMITING VALUES

In accordance with Absolute Maximum Rating System (IEC 134).

SYMBOL	PARAMETER	CONDITIONS	MIN.	MAX.	UNIT
V_{CC}	DC supply voltage	$T_{amb} = -40$ to $+150$ °C; $I_{out (low)} = 20$ mA	–	16	V
V_{out}	output voltage		–0.5	+10	V
T_{stg}	storage temperature		–40	+150	°C
T_{amb}	ambient operating temperature		–40	+150	°C
T_{sld}	soldering temperature	$t \leq 10$ s	–	260	°C

CHARACTERISTICS

$T_{amb} = 25$ °C; $V_{CC} = 12$ V; $d = 1.9$ mm; $f_t = 2$ kHz; test circuit: see Fig.5; sensor positioning: see Fig.11; gear wheel: module 2 mm; material 1.0715; see Fig.6; unless otherwise specified.

SYMBOL	PARAMETER	CONDITIONS	MIN.	TYP.	MAX.	UNIT
$V_{out (low)}$	remaining open collector voltage	$I_{out (low)} = 10$ mA	–	–	0.5	V
		$I_{out (low)} = 20$ mA	–	–	1	V
t_r	output signal rise time	10 to 90% value	–	11.5	–	µs
t_f	output signal fall time	10 to 90% value	–	0.3	–	µs
t_d	switching delay time	between stimulation pulse (generated by a coil) and output signal	–	1	–	µs
f_t	operating tooth frequency	for both rotation directions	0	–	25000	Hz
d_{min}	minimum sensing distance	target wheel $m = 2$ mm; see Fig.11; and note 1	–	0.3	–	mm
d_{max}	maximum sensing distance	target wheel $m = 2$ mm; see Fig.11; and note 1	–	2	–	mm
δ	duty cycle		30	50	70	%

Note

1. High rotational speeds of wheels reduce the sensing distance due to eddy current effects (see Fig.13).

Integrated rotational speed sensor

KMI16/1

FUNCTIONAL DESCRIPTION

The KMI16/1 sensor is sensitive to the motion of ferrous gear wheels or reference marks. The functional principle is shown in Fig.3. Due to the effect of flux bending, the different directions of magnetic field lines in the magneto-resistive sensor element will cause an electrical signal. Because of the chosen sensor orientation and the direction of ferrite magnetization, the KMI16/1 is sensitive to movement in the 'y' direction in front of the sensor only (see Fig.2).

The magneto-resistive sensor element signal is amplified, temperature compensated and passed to a Schmitt trigger in the conditioning integrated circuit (Fig 4). The digital output signal level is independent of the sensing distance within the measuring range (Fig.10). A (3-wire) output current enables safe transfer of the sensor signal to the detecting circuit (see Fig.5). The integrated circuit housing is separated from the sensor element housing to optimize the sensor behaviour at high temperatures.

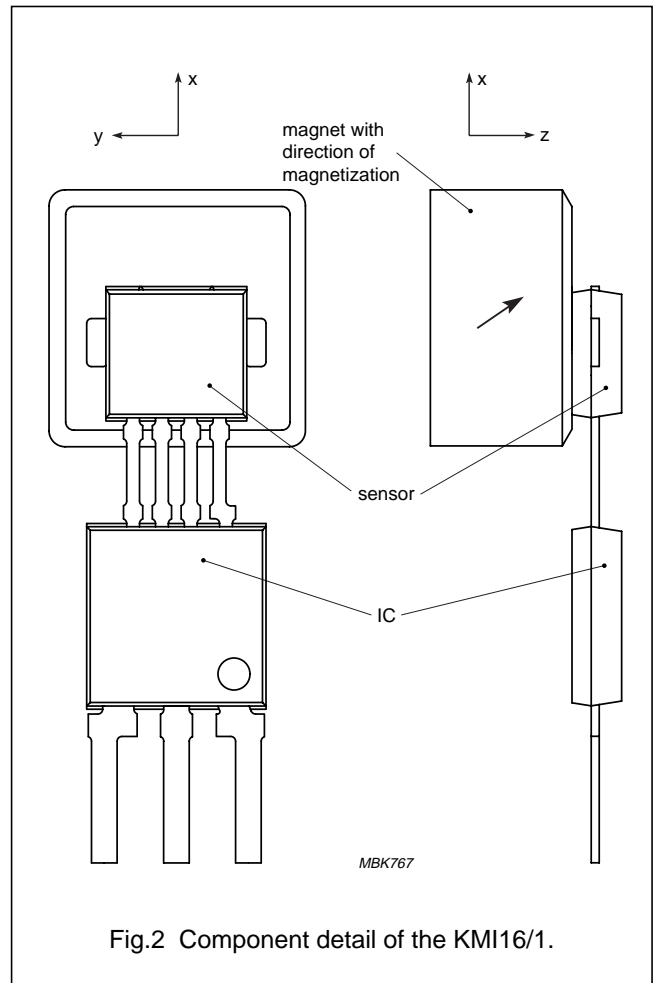

Fig.2 Component detail of the KMI16/1.

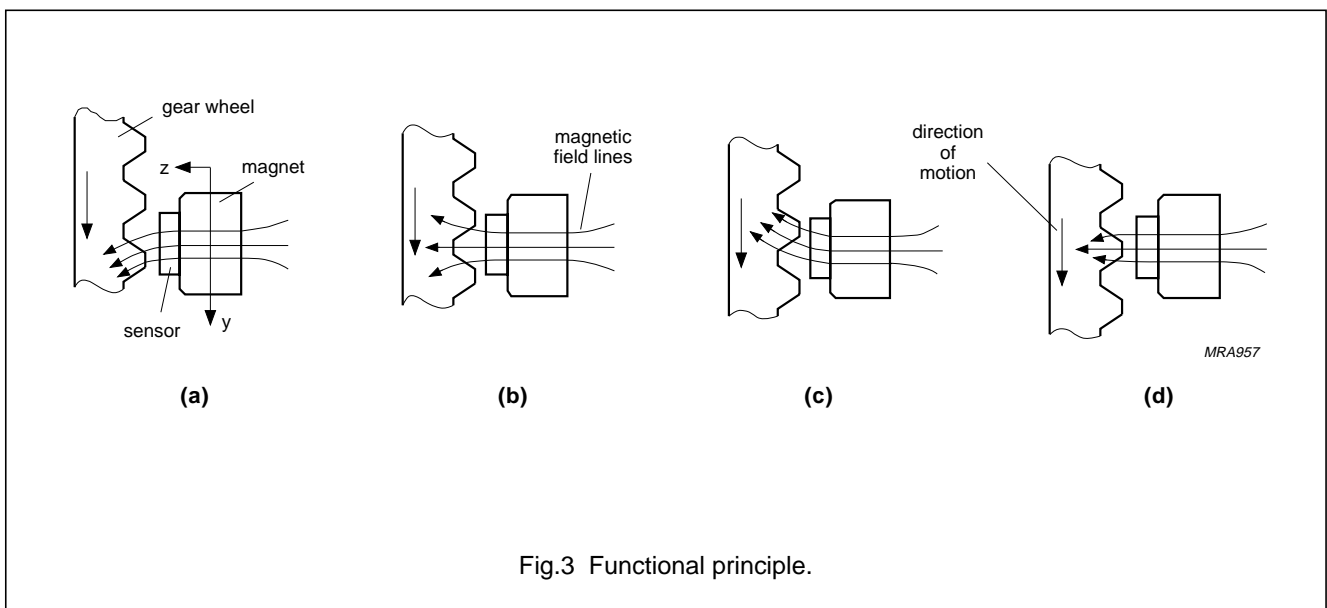

Fig.3 Functional principle.

Integrated rotational speed sensor

KMI16/1

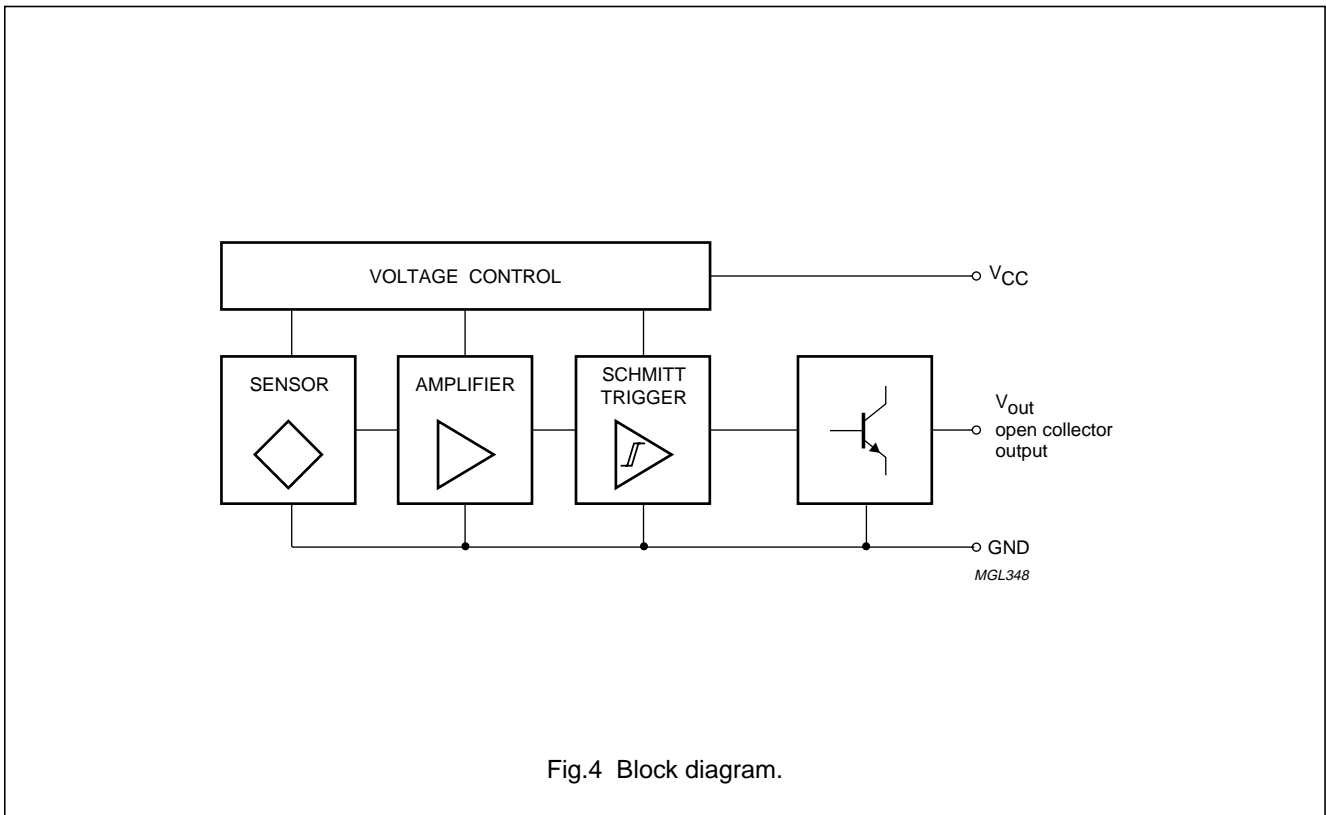

Fig.4 Block diagram.

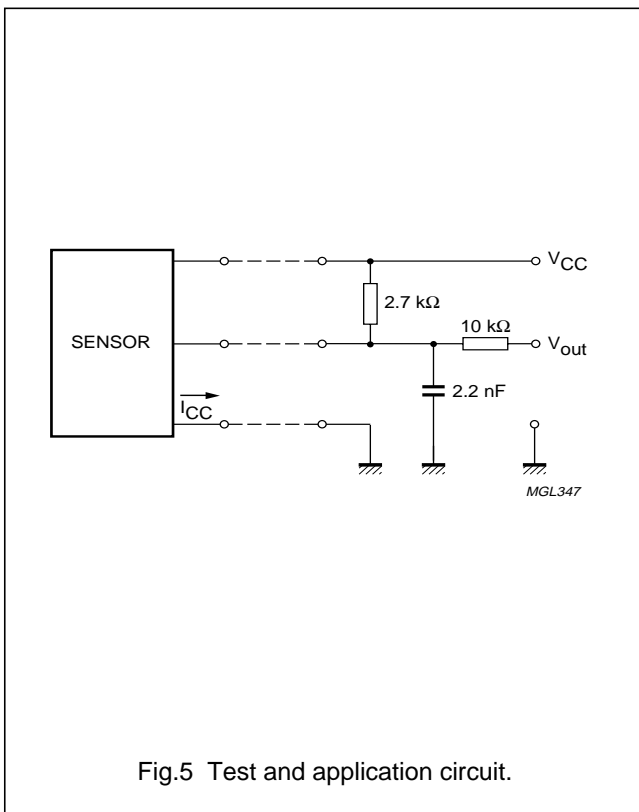

Fig.5 Test and application circuit.

Integrated rotational speed sensor

KMI16/1

APPLICATION INFORMATION

Mounting conditions

The recommended sensor position in front of a gear wheel is shown in Fig.11. The distance 'd' is measured between the sensor front and the tip of a gear wheel tooth. The KMI16/1 senses ferrous indicators like gear wheels in the ± y direction only (no rotational symmetry of the sensor); see Fig.2. The effect of incorrect mounting positions on sensing distance is shown in Figs 7, 8 and 9. The symmetrical reference axis of the sensor corresponds to the axis of the ferrite magnet.

Environmental conditions

Due to eddy current effects the sensing distance depends on the tooth frequency (Fig.13). The influence of gear wheel module on the sensing distance is shown in Fig.12.

Gear Wheel Dimensions

SYMBOL	DESCRIPTION	UNIT
German DIN		
z	number of teeth	
d	diameter	mm
m	module $m = d/z$	mm
p	pitch $p = \pi \times m$	mm
ASA; note 1		
PD	pitch diameter (d in inch)	inch
DP	diametric pitch $DP = z/PD$	inch ⁻¹
CP	circular pitch $CP = \pi/DP$	inch

Note

1. For conversion from ASA to DIN: $m = 25.4 \text{ mm}/DP$; $p = 25.4 \text{ mm} \times CP$.

Integrated rotational speed sensor

KMI16/1

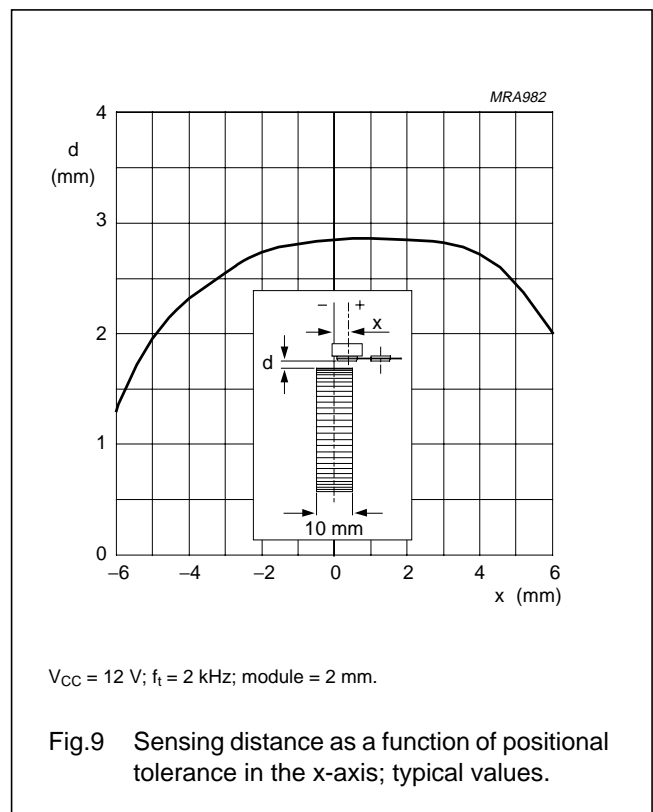
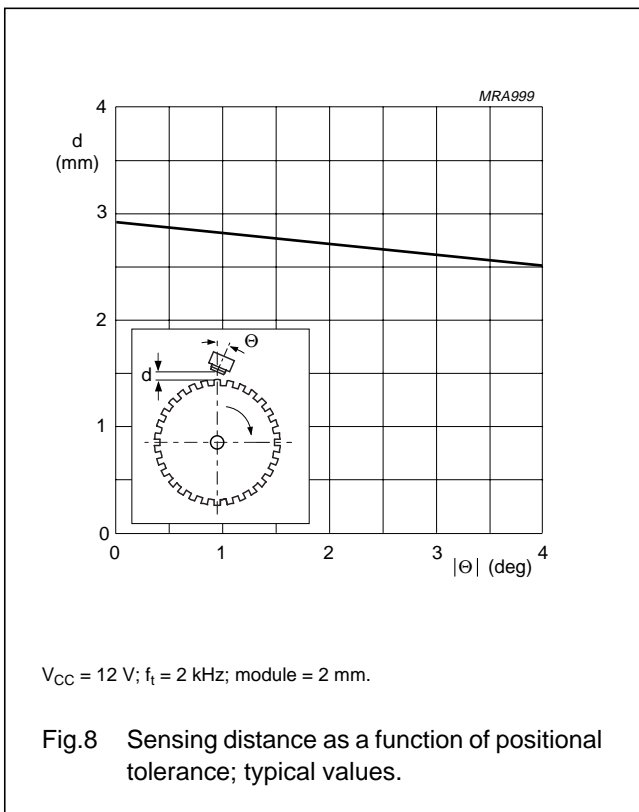
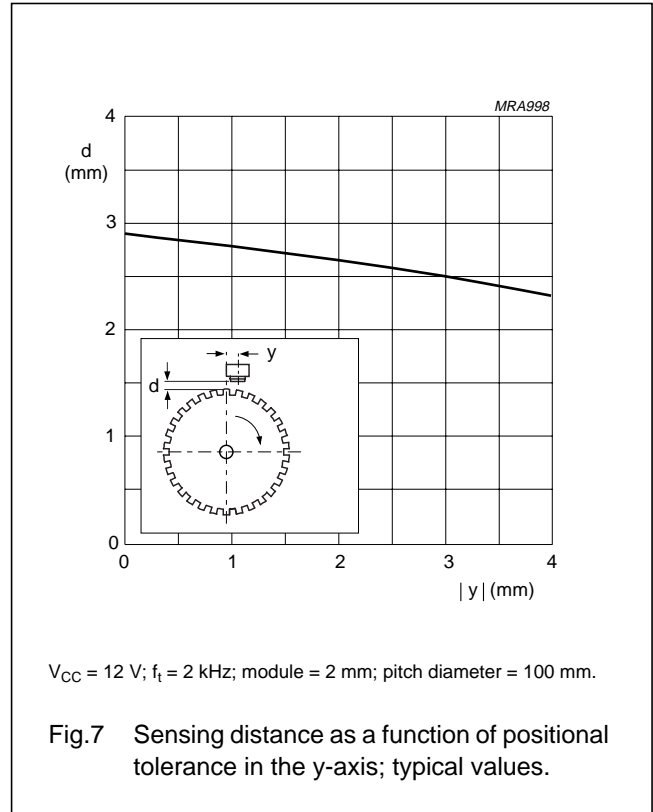
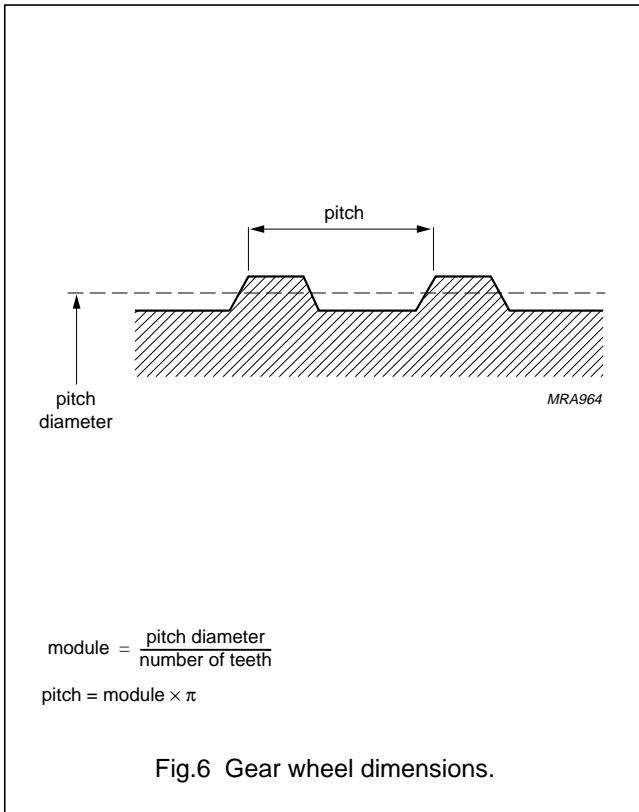

Integrated rotational speed sensor

KMI16/1

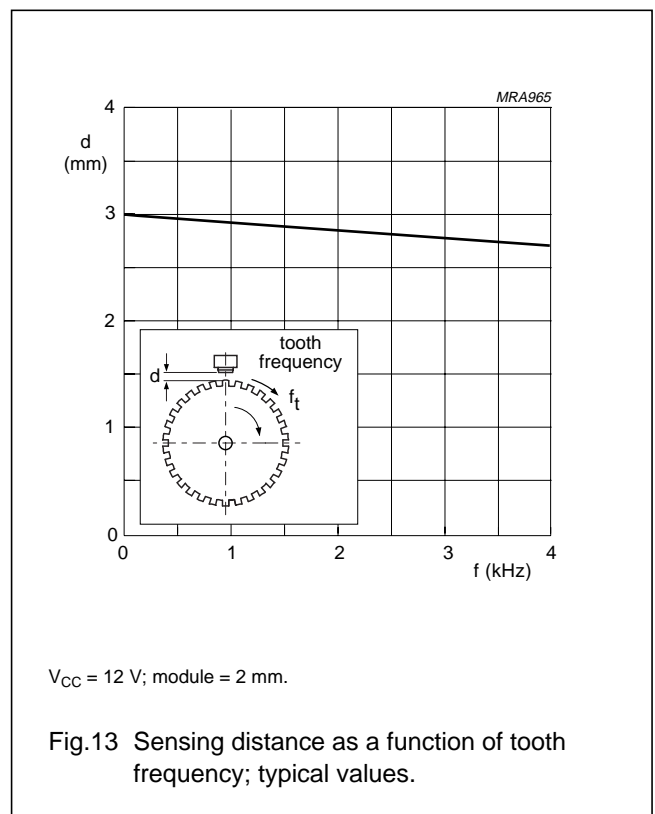
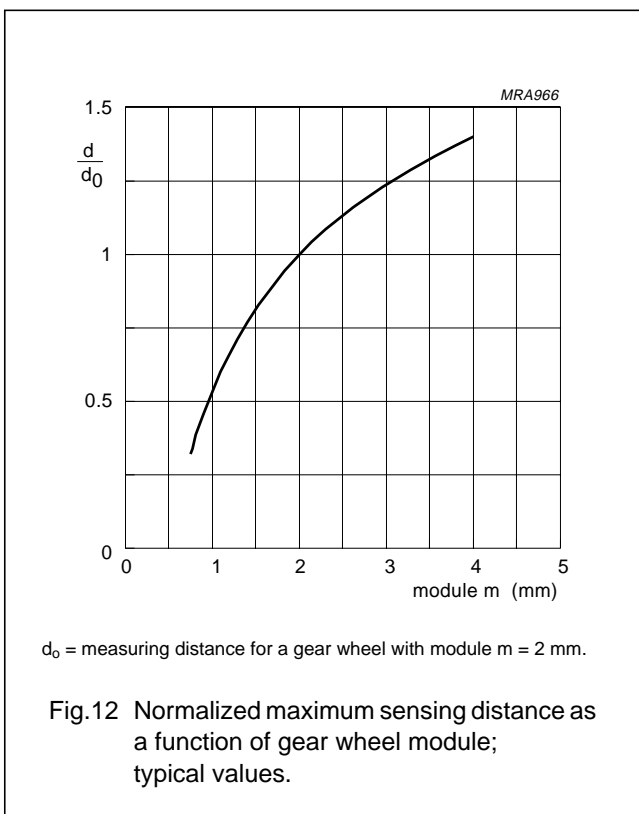
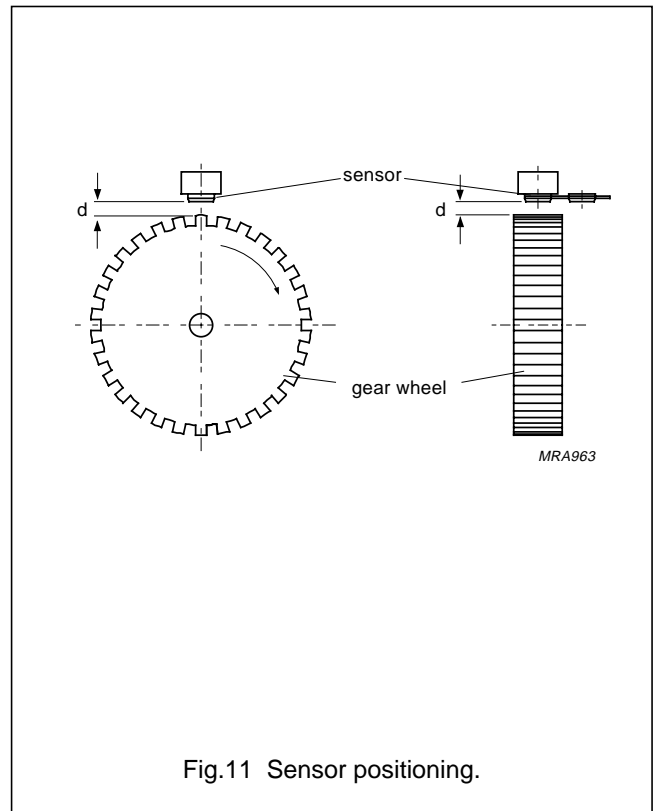
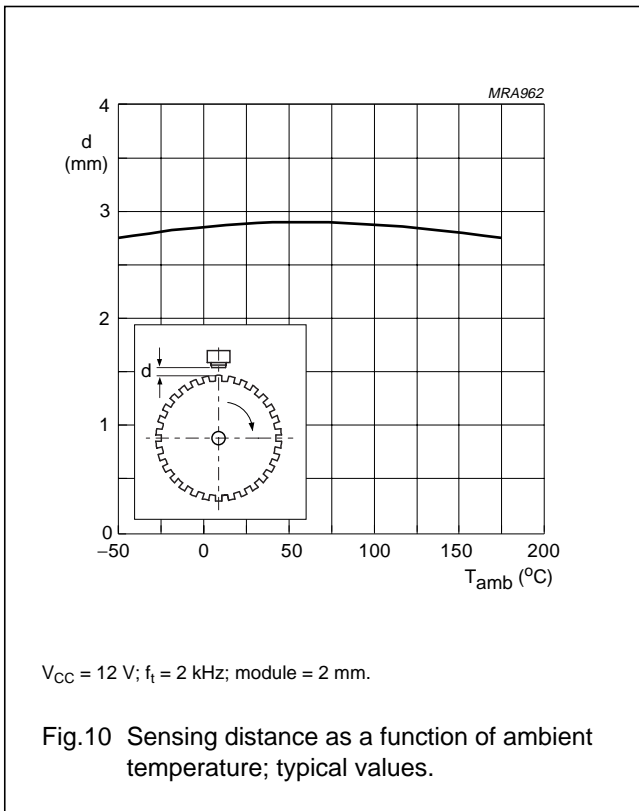

Integrated rotational speed sensor

KMI16/1

PACKAGE OUTLINE

Plastic single-ended combined package; magnetoresistive sensor element; bipolar IC; magnetized ferrite magnet (5.5 x 5.5 x 3.0 mm); 3 in-line leads

SOT477B

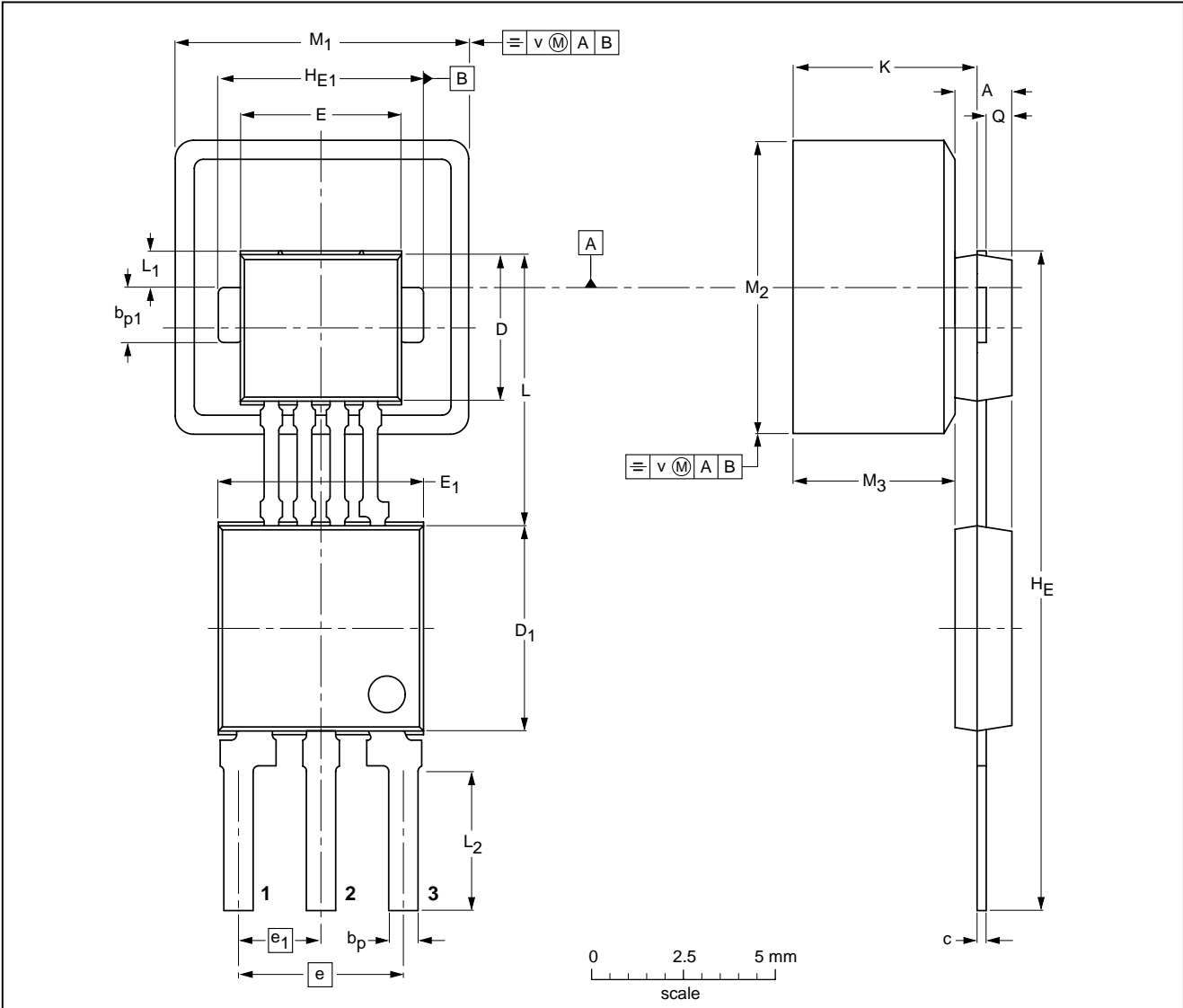

DIMENSIONS (mm are the original dimensions)

UNIT	A	b _p	b _{p1}	c	D ⁽¹⁾	D ₁ ⁽¹⁾	E ⁽¹⁾	E ₁ ⁽¹⁾	e	e ₁	H _E	H _{E1}	K max.	L	L ₁	L ₂	M ₁	M ₂	M ₃	Q	v
mm	1.7 1.4	0.8 0.7	1.57 1.47	0.3 0.24	4.1 3.9	5.7 5.5	4.5 4.3	5.7 5.5	4.6 4.4	2.35 2.15	18.2 17.8	5.6 5.5	7.55 7.25	7.55 7.25	1.2 0.9	3.9 3.5	8.15 7.85	8.15 7.85	4.7 4.3	0.75 0.65	0.25

Note

1. Plastic or metal protrusions of 0.15 mm maximum per side are not included.

OUTLINE VERSION	REFERENCES				EUROPEAN PROJECTION	ISSUE DATE
	IEC	JEDEC	EIAJ			
SOT477B						98-05-12

Integrated rotational speed sensor
KMI16/1

DEFINITIONS

Data sheet status	
Objective specification	This data sheet contains target or goal specifications for product development.
Preliminary specification	This data sheet contains preliminary data; supplementary data may be published later.
Product specification	This data sheet contains final product specifications.
Limiting values	
Limiting values given are in accordance with the Absolute Maximum Rating System (IEC 134). Stress above one or more of the limiting values may cause permanent damage to the device. These are stress ratings only and operation of the device at these or at any other conditions above those given in the Characteristics sections of the specification is not implied. Exposure to limiting values for extended periods may affect device reliability.	
Application information	
Where application information is given, it is advisory and does not form part of the specification.	

LIFE SUPPORT APPLICATIONS

These products are not designed for use in life support appliances, devices, or systems where malfunction of these products can reasonably be expected to result in personal injury. Philips customers using or selling these products for use in such applications do so at their own risk and agree to fully indemnify Philips for any damages resulting from such improper use or sale.

Integrated rotational speed sensor

KMI16/1

NOTES

Philips Semiconductors – a worldwide company

Argentina: see South America

Australia: 34 Waterloo Road, NORTH RYDE, NSW 2113, Tel. +61 2 9805 4455, Fax. +61 2 9805 4466

Austria: Computerstr. 6, A-1101 WIEN, P.O. Box 213, Tel. +43 160 1010, Fax. +43 160 101 1210

Belarus: Hotel Minsk Business Center, Bld. 3, r. 1211, Volodarski Str. 6, 220050 MINSK, Tel. +375 172 200 733, Fax. +375 172 200 773

Belgium: see The Netherlands

Brazil: see South America

Bulgaria: Philips Bulgaria Ltd., Energoproject, 15th floor, 51 James Bourchier Blvd., 1407 SOFIA, Tel. +359 2 689 211, Fax. +359 2 689 102

Canada: PHILIPS SEMICONDUCTORS/COMPONENTS, Tel. +1 800 234 7381

China/Hong Kong: 501 Hong Kong Industrial Technology Centre, 72 Tat Chee Avenue, Kowloon Tong, HONG KONG, Tel. +852 2319 7888, Fax. +852 2319 7700

Colombia: see South America

Czech Republic: see Austria

Denmark: Prags Boulevard 80, PB 1919, DK-2300 COPENHAGEN S, Tel. +45 32 88 2636, Fax. +45 31 57 0044

Finland: Sinikalliontie 3, FIN-02630 ESPOO, Tel. +358 9 615800, Fax. +358 9 61580920

France: 51 Rue Carnot, BP317, 92156 SURESNES Cedex, Tel. +33 1 40 99 6161, Fax. +33 1 40 99 6427

Germany: Hammerbrookstraße 69, D-20097 HAMBURG, Tel. +49 40 23 53 60, Fax. +49 40 23 536 300

Greece: No. 15, 25th March Street, GR 17778 TAVROS/ATHENS, Tel. +30 1 4894 339/239, Fax. +30 1 4814 240

Hungary: see Austria

India: Philips INDIA Ltd, Band Box Building, 2nd floor, 254-D, Dr. Annie Besant Road, Worli, MUMBAI 400 025, Tel. +91 22 493 8541, Fax. +91 22 493 0966

Indonesia: PT Philips Development Corporation, Semiconductors Division, Gedung Philips, Jl. Buncit Raya Kav.99-100, JAKARTA 12510, Tel. +62 21 794 0040 ext. 2501, Fax. +62 21 794 0080

Ireland: Newstead, Clonskeagh, DUBLIN 14, Tel. +353 1 7640 000, Fax. +353 1 7640 200

Israel: RAPAC Electronics, 7 Kehilat Saloniki St, PO Box 18053, TEL AVIV 61180, Tel. +972 3 645 0444, Fax. +972 3 649 1007

Italy: PHILIPS SEMICONDUCTORS, Piazza IV Novembre 3, 20124 MILANO, Tel. +39 2 6752 2531, Fax. +39 2 6752 2557

Japan: Philips Bldg 13-37, Kohnan 2-chome, Minato-ku, TOKYO 108-8507, Tel. +81 3 3740 5130, Fax. +81 3 3740 5077

Korea: Philips House, 260-199 Itaewon-dong, Yongsan-ku, SEOUL, Tel. +82 2 709 1412, Fax. +82 2 709 1415

Malaysia: No. 76 Jalan Universiti, 46200 PETALING JAYA, SELANGOR, Tel. +60 3 750 5214, Fax. +60 3 757 4880

Mexico: 5900 Gateway East, Suite 200, EL PASO, TEXAS 79905, Tel. +9-5 800 234 7381

Middle East: see Italy

Netherlands: Postbus 90050, 5600 PB EINDHOVEN, Bldg. VB, Tel. +31 40 27 82785, Fax. +31 40 27 88399

New Zealand: 2 Wagener Place, C.P.O. Box 1041, AUCKLAND, Tel. +64 9 849 4160, Fax. +64 9 849 7811

Norway: Box 1, Manglerud 0612, OSLO, Tel. +47 22 74 8000, Fax. +47 22 74 8341

Pakistan: see Singapore

Philippines: Philips Semiconductors Philippines Inc., 106 Valero St. Salcedo Village, P.O. Box 2108 MCC, MAKATI, Metro MANILA, Tel. +63 2 816 6380, Fax. +63 2 817 3474

Poland: Ul. Lukiska 10, PL 04-123 WARSZAWA, Tel. +48 22 612 2831, Fax. +48 22 612 2327

Portugal: see Spain

Romania: see Italy

Russia: Philips Russia, Ul. Usatcheva 35A, 119048 MOSCOW, Tel. +7 095 755 6918, Fax. +7 095 755 6919

Singapore: Lorong 1, Toa Payoh, SINGAPORE 319762, Tel. +65 350 2538, Fax. +65 251 6500

Slovakia: see Austria

Slovenia: see Italy

South Africa: S.A. PHILIPS Pty Ltd., 195-215 Main Road Martindale, 2092 JOHANNESBURG, P.O. Box 7430 Johannesburg 2000, Tel. +27 11 470 5911, Fax. +27 11 470 5494

South America: Al. Vicente Pinzon, 173, 6th floor, 04547-130 SÃO PAULO, SP, Brazil, Tel. +55 11 821 2333, Fax. +55 11 821 2382

Spain: Balmes 22, 08007 BARCELONA, Tel. +34 93 301 6312, Fax. +34 93 301 4107

Sweden: Kottbygatan 7, Akalla, S-16485 STOCKHOLM, Tel. +46 8 5985 2000, Fax. +46 8 5985 2745

Switzerland: Allmendstrasse 140, CH-8027 ZÜRICH, Tel. +41 1 488 2741 Fax. +41 1 488 3263

Taiwan: Philips Semiconductors, 6F, No. 96, Chien Kuo N. Rd., Sec. 1, TAIPEI, Taiwan Tel. +886 2 2134 2865, Fax. +886 2 2134 2874

Thailand: PHILIPS ELECTRONICS (THAILAND) Ltd., 209/2 Sanpavuth-Bangna Road Prakanong, BANGKOK 10260, Tel. +66 2 745 4090, Fax. +66 2 398 0793

Turkey: Talatpasa Cad. No. 5, 80640 GÜLTEPE/ISTANBUL, Tel. +90 212 279 2770, Fax. +90 212 282 6707

Ukraine: PHILIPS UKRAINE, 4 Patrice Lumumba str., Building B, Floor 7, 252042 KIEV, Tel. +380 44 264 2776, Fax. +380 44 268 0461

United Kingdom: Philips Semiconductors Ltd., 276 Bath Road, Hayes, MIDDLESEX UB3 5BX, Tel. +44 181 730 5000, Fax. +44 181 754 8421

United States: 811 East Arques Avenue, SUNNYVALE, CA 94088-3409, Tel. +1 800 234 7381

Uruguay: see South America

Vietnam: see Singapore

Yugoslavia: PHILIPS, Trg N. Pasica 5/v, 11000 BEOGRAD, Tel. +381 11 625 344, Fax. +381 11 635 777

For all other countries apply to: Philips Semiconductors, International Marketing & Sales Communications, Building BE-p, P.O. Box 218, 5600 MD EINDHOVEN, The Netherlands, Fax. +31 40 27 24825

Internet: <http://www.semiconductors.philips.com>

© Philips Electronics N.V. 1998

SCA60

All rights are reserved. Reproduction in whole or in part is prohibited without the prior written consent of the copyright owner.

The information presented in this document does not form part of any quotation or contract, is believed to be accurate and reliable and may be changed without notice. No liability will be accepted by the publisher for any consequence of its use. Publication thereof does not convey nor imply any license under patent- or other industrial or intellectual property rights.

Printed in The Netherlands

115106/1200/01/pp12

Date of release: 1998 May 15

Document order number: 9397 750 03883

Let's make things better.

**Philips
Semiconductors**



PHILIPS