

31W TRIPLE OUTPUT STEP-DOWN SWITCHING REGULATORS

Type	V_i	V_o	I_o
GS-R51212S	15 to 40 V	+ 5,1 V	4,5 A
		± 12 V	0,35 A
GS-R51515S	15 to 40 V	+ 5,1 V	4,5 A
		± 15 V	0,3 A

FEATURES

- 5.1V/4.5A and ±12V/0.35A or ±15V/0.3A output voltages
- ±12 or ±15V externally adjustable
- High efficiency (81% typ.)
- Short-circuit protection
- Reset output
- Power Fail programmable input
- Inhibit/Enable control input
- Soft-start
- PCB or chassis mounting

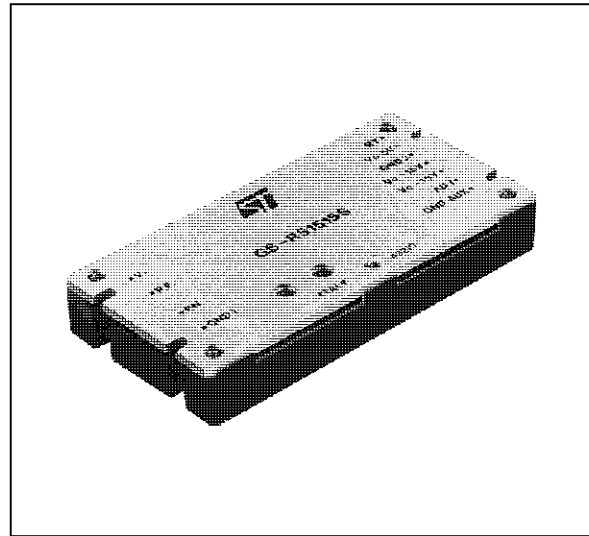

DESCRIPTION

The GS-R51212S and GS-R51515S are versatile triple output, high current step-down switching regulators that provide +5.1V/4.5A output voltage and an isolated ±12V/0.35A or ±15V/0.3A dual output voltage.

They are ideal for microprocessor based boards because power the logic and the communication ports and have Reset output and Power Fail programmable input for the correct system start-up.

The Inhibit/Enable pin allows the ON/OFF logic function with TTL/CMOS compatible input signal. The auxiliary outputs (±12V or ±15V) are externally adjustable in a very wide range, i.e. from ±4.25V to ±12.45V on GS-R51212S and from ±4.50V to ±15.25V (typical values) on GS-R51515S.

ABSOLUTE MAXIMUM RATINGS

Symbol	Parameter	Value	Unit
V_i	DC Input Voltage	44	V
I_{rs}	Reset Output Sink Current	20	mA

GS-R51212S/GS-R51515S

ELECTRICAL CHARACTERISTICS (T_{amb} = 25°C unless otherwise specified)

Symbol	Parameter	Test Conditions	Min	Typ	Max	Unit
V _i	Input Voltage GS-R51212S	V _{o1} = +5.1V I _{o1} = 4.5A V _{o2} = +12V I _{o2} = 0.35A V _{o3} = -12V I _{o3} = -0.35A	15		40	V
V _i	Input Voltage GS-R51515S	V _{o1} = +5.1V I _{o1} = 4.5A V _{o2} = +15V I _{o2} = 0.3A V _{o3} = -15V I _{o3} = -0.3A	15		40	V
I _{ir}	Input Reflected Current	V _i = 24V I _{o1,2,3} = Full Load No external input capacitor		0.5		App
I _{ir}	Input Reflected Current	V _i = 24V I _{o1,2,3} = Full Load C _i (external) = 100µF/50V		0.15		App
V _{ien}	Enable Input Voltage	V _i = 15 to 40V	0		0.8	V
I _{ien}	Enable Input Current	V _i = 15 to 40V			-1	mA
V _{iinh}	Inhibit Input Voltage	V _i = 15 to 40V	1.2		+V _i	V
V _{o1}	Output Voltage 1	V _i = 15 to 40V I _{o1} = 0 to 4.5A I _{o2} = 0 to 0.35/0.3A I _{o3} = 0 to -0.35/-0.3A	+5	+5.1	+5.2	V
V _{o2}	Output Voltage 2 GS-R51212S	V _i = 15 to 40V I _{o1} = 0 to 4.5A I _{o2} = 0 to 0.35A I _{o3} = 0 to -0.35A	+11.5	+12	+12.5	V
V _{o2}	Output Voltage 2 GS-R51515S	V _i = 15 to 40V I _{o1} = 0 to 4.5A I _{o2} = 0 to 0.3A I _{o3} = 0 to -0.3A	+14.5	+15	+15.5	V
V _{o3}	Output Voltage 3 GS-R51212S	V _i = 15 to 40V I _{o1} = 0 to 4.5A I _{o2} = 0 to 0.35A I _{o3} = 0 to -0.35A	-11.5	-12	-12.5	V
V _{o3}	Output Voltage 3 GS-R51515S	V _i = 15 to 40V I _{o1} = 0 to 4.5A I _{o2} = 0 to 0.3A I _{o3} = 0 to -0.3A	-14.5	-15	-15.5	V
V _{or1}	Output Ripple Voltage 1	V _i = 24V I _{o1} = 4.5A		30	50	mVpp
V _{or2,3}	Output Ripple Voltage 2,3	V _i = 24V I _{o2,3} = 0.35/0.3A		50	100	mVpp
δVOL1	Line Regulation 1	V _i = 15 to 40V I _{o1} = 2.5A I _{o2,3} = 0.35/0.3A		0.5		mV/V
δVOL2,3	Line Regulation 2,3	V _i = 15 to 40V I _{o1} = 2.5A I _{o2,3} = 0.35/0.3A		1		mV/V
δVOO1	Load Regulation 1	V _i = 24V I _{o1} = 0.5 to 4.5A I _{o2,3} = 0.35/0.3A		2		mV/A
δVOO2,3	Load Regulation 2,3	V _i = 24V I _{o1} = 2.5A I _{o2,3} = 0.05 to 0.35/0.3A		500		mV/A
I _{o1}	Output Current 1	V _i = 15 to 40V V _{o1} = 5.1V I _{o2,3} = 0 to 0.35/0.3A	0		4.5	A
I _{o2}	Output Current 2* GS-R51212S	V _i = 15 to 40V I _{o1} = 0 to 4.5A V _{o2} = +12V I _{o3} = 0 to -0.35A	0		0.35	A
I _{o2}	Output Current 2* GS-R51515S	V _i = 15 to 40V I _{o1} = 0 to 4.5A V _{o2} = +15V I _{o3} = 0 to -0.3A	0		0.3	A
I _{o2}	Output Current 2* GS-R51212S	V _i = 15 to 40V I _{o1} = 0 to 4.5A V _{o2} = +12V I _{o3} = 0A	0		0.7	A
I _{o2}	Output Current 2* GS-R51515S	V _i = 15 to 40V I _{o1} = 0 to 4.5A V _{o2} = +15V I _{o3} = 0A	0		0.6	A
I _{o3}	Output Current 3* GS-R51212S	V _i = 15 to 40V I _{o1} = 0 to 4.5A V _{o3} = -12V I _{o2} = 0 to 0.35A	0		-0.35	A

ELECTRICAL CHARACTERISTICS ($T_{amb} = 25^{\circ}\text{C}$ unless otherwise specified) (cont'd)

Symbol	Parameter	Test Conditions	Min	Typ	Max	Unit
Io3	Output Current 3* GS-R51515S	$V_i = 15$ to 40V $I_{o1} = 0$ to 4.5A $V_{o3} = -15\text{V}$ $I_{o2} = 0$ to 0.3A	0		-0.3	A
Io3	Output Current 3* GS-R51212S	$V_i = 15$ to 40V $I_{o1} = 0$ to 4.5A $V_{o3} = -12\text{V}$ $I_{o2} = 0\text{A}$	0		-0.7	A
Io3	Output Current 3* GS-R51515S	$V_i = 15$ to 40V $I_{o1} = 0$ to 4.5A $V_{o3} = -15\text{V}$ $I_{o2} = 0\text{A}$	0		-0.6	A
Iosck1	Output Current Limit 1	$V_i = 15$ to 40V Overload		5.5		A
Iosc1	Output Short-circuit Current 1	$V_i = 15$ to 40V		3		A
Iosc2,3	Output Short-circuit Current 2,3	$V_i = 15$ to 40V		0.8		A
tss	Soft-start time			10		ms
tdr	Reset Time Delay			100		ms
fs	Switching Frequency	$V_i = 15$ to 40V $V_{o1} = 5.1\text{V}$ $I_{o1} = 0.5$ to 4.5A $V_{o2} = +12/+15\text{V}$ $V_{o3} = -12/-15\text{V}$ $I_{o2}, I_{o3} = -0.05$ to $-0.35/-0.3\text{A}$		100		kHz
η	Efficiency	$V_i = 24\text{V}$ $I_{o1,2,3} = \text{Full Load}$	78	81		%
Rth	Thermal Resistance			7.5		$^{\circ}\text{C}/\text{W}$
Tcop	Operating Case Temperature Range		0		+85	$^{\circ}\text{C}$
Tstg	Storage Temperature Range		-40		+105	$^{\circ}\text{C}$

* Note: when output current is less than 50mA, output ripple voltage increases due to discontinuous operation.

CONNECTION DIAGRAM AND MECHANICAL DATA

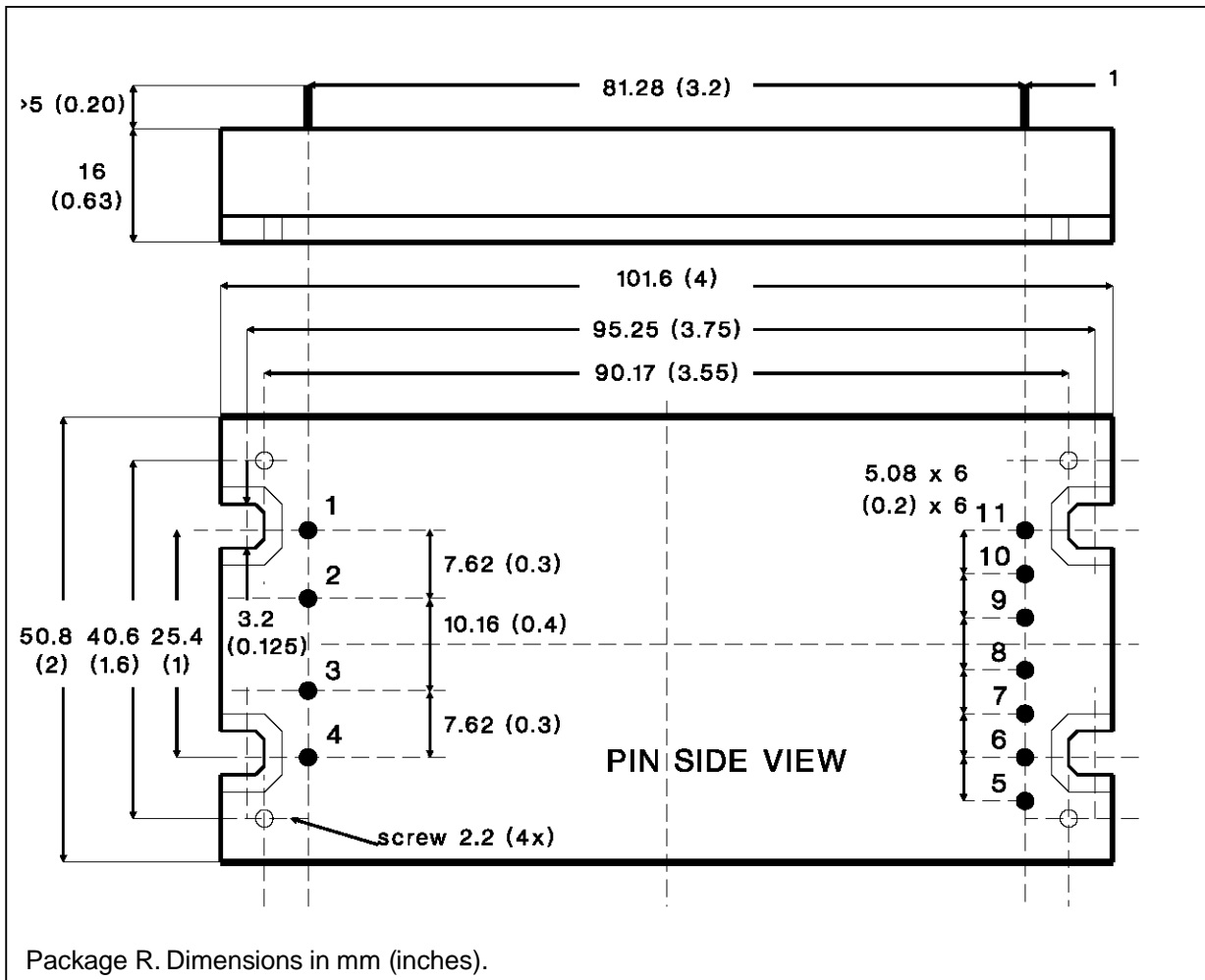

PIN DESCRIPTION

Pin	Function	Description
1	GND IN	Return for input voltage source. Internally connected to pin 7.
2	$\overline{\text{EN}}$.	Inhibit/Enable control input. The converter is ON (ENABLE) when the voltage applied to this pin is lower than 0.8V. The converter is OFF (INHIBIT) when this pin is unconnected or the input voltage is in the range of 1.2 to V_i .
3	P.F.	Power Fail programmable input. If unconnected the Power Fail threshold voltage is 11V with 1V hysteresis (factory setting).
4	+ V_{in}	DC input voltage. Recommended maximum voltage is 40V.
5	RT	Reset output (active high). When the supply voltage + V_{in} and the regulated output voltage + V_{o1} are in the correct range this signal is generated after a delay time of 100ms typical.
6	$V_o + 5V$	Regulated +5.1V output voltage.
7	GND 1	Return for output 1 current path. Internally connected to pin 1.
8	$V_o + 12/15V$	Regulated +12 or +15V output.
9	$V_o - 12/15V$	Regulated - 12 or - 15V output.
10	ADJ.	External adjustment for output voltages ± 12 and $\pm 15V$.
11	GND Aux.	Return for ± 12 and $\pm 15V$ output current path.

USER NOTES

Input Voltage

The recommended operating maximum DC input voltage is 40V inclusive of the ripple voltage. The use of an external low ESR, high ripple current capacitor located as close the module as possible is recommended; suggested value is 100µF/50V.

Soft-start

To avoid heavy inrush current the output voltage rise time is typically 10ms in any condition of load.

Power Fail-Reset Circuit

The module include a voltage sensing circuit that may be used to generate a power-on/power-off reset signal for a microprocessor system.

The circuit sense the input supply voltage and the output generated voltage Vo1 (+5V) and will generate the required reset signal only when both the sensed voltages have reached the required value for correct system operation.

When both the supply voltage and the regulated voltage are in the correct range the output Reset signal is generated after a delay time tDR of 100ms typical.

A latch assures that if a spike is present on the sensed voltage the delay time circuit discharges completely before initialization of a new reset cycle.

Reset output has internal pull-up resistor of 10kOhm connected to Vo +5V pin. Maximum sink output current is 20mA at VRESET(sat) = 200mV.

Fig. 1 and fig. 2 show reset waveforms.

Power Fail Programmable Input

This pin is internally connected via a divider to the +Vin pin for Power Fail function.

The factory setting is for a value of 11V with 1V hysteresis.

It is possible to program a different value of Power Fail threshold by connecting a resistor (Rpf) between pin 3 (Power Fail Input) and pin 1 (GND Input). The value of Rpf must be calculated according to the following formula:

$$R_{pf} = \frac{5.1}{\frac{V_{pf} - 5.1}{34} - 0.191} = (k\Omega)$$

where Vpf is the desired value of Power Fail threshold voltage.

Example: Vpf = 24V (must not be lower than 12V):

$$R_{pf} = \frac{5.1}{\frac{24 - 5.1}{34} - 0.191} = 14k\Omega$$

Figure 1 - Reset and Power Fail waveforms.

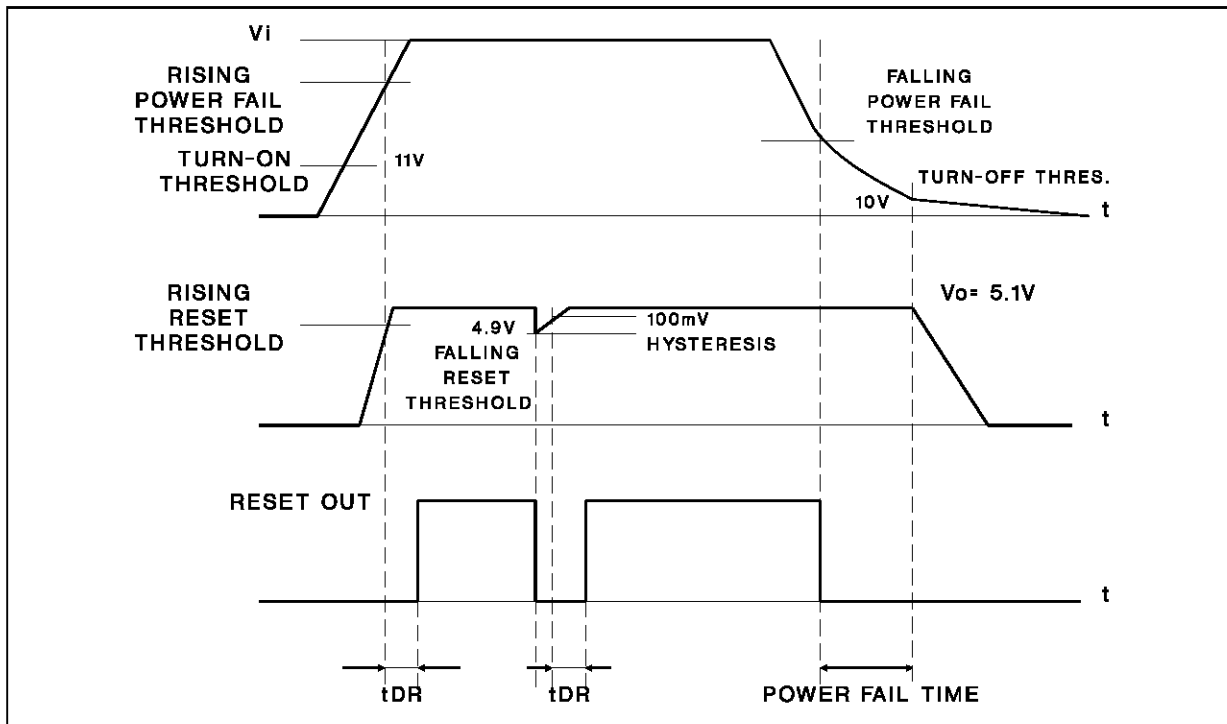
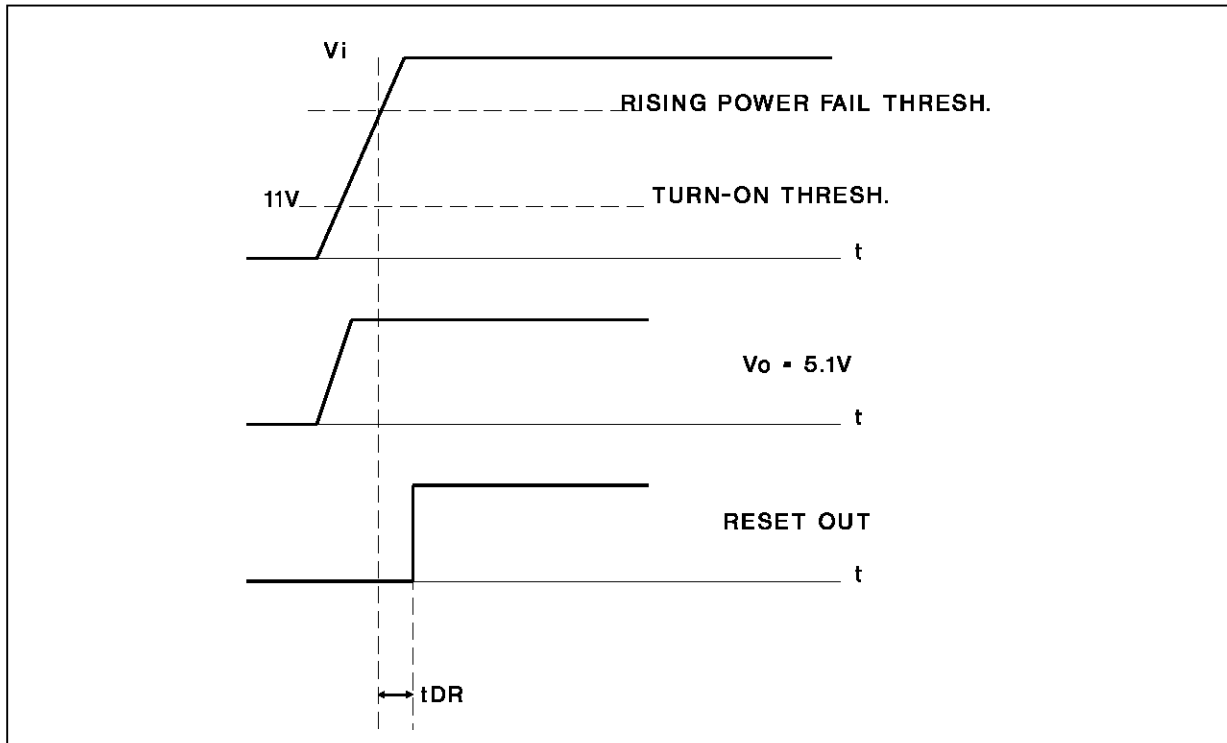

Figure 2 - Reset and Power Fail waveforms.



Auxiliary Outputs

The auxiliary outputs ($\pm 12V$ or $\pm 15V$) are externally adjustable in symmetric way by connecting a resistor R_a between pin 10 (ADJ.) and pin 8 ($V_o + 12/+15V$), according to the following formula:

$$\text{GS-R51212S} \quad R_a = 32.66 \times \frac{V_o - 4.229}{12.485 - V_o}$$

$$\text{GS-R51515S} \quad R_a = 38.66 \times \frac{V_o - 4.39}{15.252 - V_o}$$

where V_o is the desired dual output voltage.

Example: $V_o = \pm 5V$.

$$R_a \text{ (GS-R51212S)} = 3.36k\Omega$$

$$R_a \text{ (GS-R51515S)} = 2.3k\Omega$$

Example: $V_o = \pm 10V$.

$$R_a \text{ (GS-R51212S)} = 75.8k\Omega$$

$$R_a \text{ (GS-R51515S)} = 41.3k\Omega$$

Figure 3 - Typical Application.

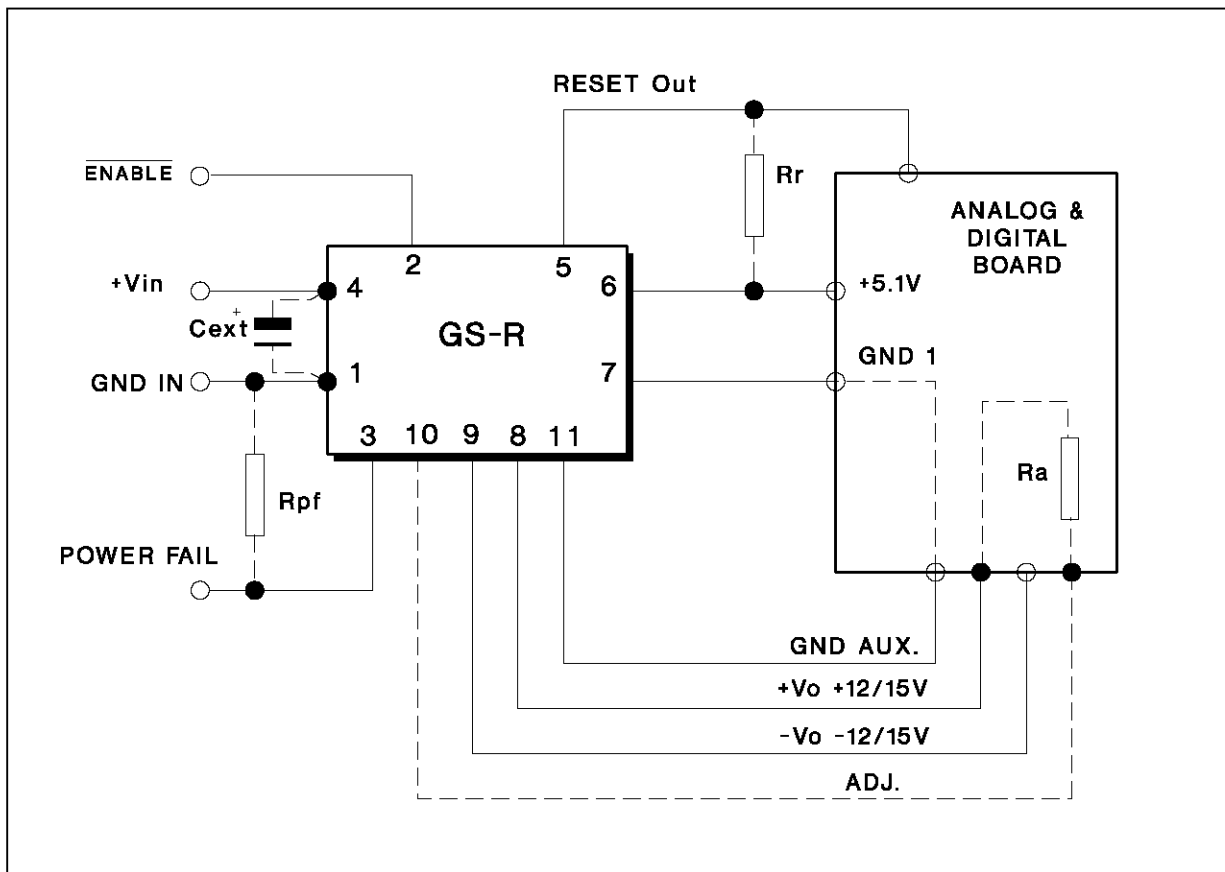

Inhibit/Enable Input

The Inhibit/Enable function allows the ON/OFF logic control of the module.

The converter is ON (Enable) when the voltage applied to pin 2 (EN.) and referred to pin 1 (GND IN) is lower than 0.8V (TTL, CMOS, open collector compatible level).

The converter is OFF (Inhibit) when pin 2 is unconnected or the voltage applied is in the range of 1.2V to +Vin. Maximum sinking current is 1mA.

Module Protection

The module is protected against occasional and permanent short-circuits of the output pins to ground, as well as against output current overload. The main output (+5.1V) uses a foldback current limiting; the output current decreases with increasing overload, reaching a minimum at short-circuit condition.

This solution minimizes internal power dissipation. The auxiliary outputs (± 12 V or ± 15 V) use a current limiting protection circuitry.

Thermal characteristics

Sometimes the GS-R51212S and GS-R51515S require an external heat-sink depending on both operating temperature conditions and power.

Before entering into calculations details, some basic concepts will be explained to better understand the problem.

The thermal resistance between two points is represented by their temperature difference in front of a specified dissipated power, and it is expressed in Degree Centigrade per Watt ($^{\circ}\text{C}/\text{W}$).

For the modules the thermal resistance case to ambient is $7.5^{\circ}\text{C}/\text{W}$. This means that an internal power dissipation of 1W will bring the case temperature at 7.5°C above the ambient temperature.

The maximum case temperature is 85°C .

Let's suppose to have a GS-R51515S that delivers the maximum output power of 31.4W at an ambient temperature of 40°C .

The dissipated power in this operating condition is about 7.4W (at typical efficiency of 81%), and the case temperature of the module will be:

$$T_{\text{case}} = T_{\text{amb}} + P_d \times R_{\text{th}} = 40 + 7.4 \times 7.5 = 95.5 \text{ }^\circ\text{C}$$

This value exceeds the maximum allowed temperature and an external heat-sink must be added. To this purpose four holes (see mechanical drawing) are provided on the metal surface of the module. To calculate this heat-sink, let's first determine what the total thermal resistance should be:

$$R_{\text{th}} = \frac{T_{\text{case(max)}} - T_{\text{amb}}}{P_d} = \frac{85 - 40}{7.4} = 5.40 \text{ }^\circ\text{C/W}$$

This value is the resulting value of the parallel connection of GS-R thermal resistance and of the additional heatsink thermal resistance.

$$\frac{R_{\text{th}}(\text{GSR}) \times R_{\text{th}}(\text{Heatsink})}{R_{\text{th}}(\text{GSR}) + R_{\text{th}}(\text{Heatsink})} = 5.40 \text{ }^\circ\text{C/W}$$

To calculate the thermal resistance of the additional heat-sink the following equation may be used:

$$R_{\text{th}}(\text{Heatsink}) = \frac{5.40 \times R_{\text{th}}(\text{GSR})}{R_{\text{th}}(\text{GSR}) - 5.40} = \frac{5.40 \times 7.5}{7.5 - 5.40} = 19.3 \text{ }^\circ\text{C/W}$$

In instead of or in addition to the external heatsink, a forced ventilation with an air speed of about 200 linear feet/minute can be used reducing the thermal resistance of the module at the specified value.

Information furnished is believed to be accurate and reliable. However, SGS-THOMSON Microelectronics assumes no responsibility for the consequences of use of such information nor for any infringement of patents or other rights of third parties which may result from its use. No license is granted by implication or otherwise under any patent or patent rights of SGS-THOMSON Microelectronics. Specification mentioned in this publication are subject to change without notice. This publication supersedes and replaces all information previously supplied. SGS-THOMSON Microelectronics products are not authorized for use as critical components in life support devices or systems without express written approval of SGS-THOMSON Microelectronics.

© 1994 SGS-THOMSON Microelectronics – All Rights Reserved

SGS-THOMSON Microelectronics GROUP OF COMPANIES

Australia - Brazil - China - France - Germany - Hong Kong - Italy - Japan - Korea - Malaysia - Malta - Morocco - The Netherlands - Singapore - Spain - Sweden - Switzerland - Taiwan - Thailand - United Kingdom - U.S.A.