

Components for Radio Frequency based Remote Control Systems

Table of contents

1. Introduction.....	1
2. Boundary conditions of remote control systems.....	2
2.1 Comparison infrared versus RF systems.....	2
2.1.1 The infrared system.....	2
2.1.2 The RF system.....	2
2.2 Transmission frequencies for RF systems.....	3
2.3 National legal prescriptions.....	4
2.4 Further boundary conditions.....	5
3. System comparison of RF remote control concepts.....	5
3.1 Standby versus polling concept.....	6
3.2 Superheterodyne or superregenerative receiver.....	7
3.3 Comparison AM- and FM operation.....	8
4. The TEMIC TELEFUNKEN receiver ICs U4311B, U4313B, U4314B.....	9
4.1 DC parameters of the receiver ICs.....	12
4.2 IF frequency response.....	13
5. Data filter and data regeneration.....	14
5.1 General.....	14
5.2 AC-coupled data filter.....	16
5.3 Quasi dc-coupled data filter.....	16
5.4 Eye pattern.....	18
5.5 Bit error rate measurements.....	20
6. AM operation.....	23
6.1 AM demodulator characteristic.....	23
6.2 Signal-to-noise ratio.....	24
7. FM operation.....	25
7.1 Discriminator characteristic and bandwidth.....	26
7.2 Signal-to-noise ratio.....	27
8. Circuit diagrams.....	29

8.1 IF test board for AM operation.....	30
8.2 IF test board for FM operation.....	32
9. Complete UHF remote control system.....	34
9.1 Circuit proposal for an UHF transmitter for AM- or FM operation.....	34
9.2 Circuit proposal for an UHF superheterodyne receiver.....	35
9.3 Complete UHF link.....	39
9.4 Summary and future considerations.....	39
10. Appendix (Study of radio wave radiation and propagation at the operating frequency and the harmonics).....	40
References.....	45

Due to some editorial changes, the numeration of tables and figures in this reprint was modified compared to the first edition. As some references of other reports are based on the first edition, the following table shows the changes.

First edition	Reprint
figure 1 to 2	figure 1 to 2
figure 3	table 1
figure 4 to 35	figure 3 to 34
figure 36 to 37	removed
figure 36 to 54	figure 33 to 51

1. Introduction

In the present age of modern communication and increasing mobility, we recognize a raising need for remote control systems. Reasons for using wireless systems are numerous and can not only be for comfort, versatility and flexibility but also for safety and cost savings. This is valid for various applications, as keyless entry systems for cars and buildings, alarm and security systems, domestic installation and wireless data transfer systems.

This paper describes functions and application hints for the U431xB **I**ntegrated **C**ircuit (IC) family and outlines a concept for a low-current UHF remote control system. This system is flexible with regard to amplitude or frequency modulation, different transmission coding and a wide range of data rates. The transmitter as well as the receiver are likewise equipped with a **S**urface **A**coustic **W**ave (SAW) resonator for purpose of frequency stabilization.

For both, the transmitter and the receiver's front end, the UHF transistors S822T/ S852T are used, as they are well-suited for low-current operation. The superheterodyne receiver is based on one of the receiver ICs U4311B, U4313B of TEMIC TELEFUNKEN microelectronic GmbH.

These monolithic ICs in bipolar technology include all necessary parts from **I**ntermediate **F**requency (IF) signal processing to data output. The receiver ICs, together with the transistors and the low-current microcontroller M43C200 family, make it possible to realize an UHF receiver with an average current consumption of approximately 1 mA. This

outstanding feature is achieved by a standby- or a polling concept in conjunction with a special circuit arrangement. Especially in the car market, which was the initial target and the biggest challenge for us, an average supply current below 1 mA is a peremptory requirement. But of course the ICs are also suited for other applications, like low voltage concepts for instance, as they work from a single supply voltage down to 3 V.

Another type of receiver IC is the U4314B, which is suited exclusively for AM operation. It achieves a supply current below 1 mA without any sleep mode, but also without baseband processing. As this IC differs very much from the types mentioned above, it won't be discussed in detail within this paper.

For purpose of encoding and decoding, the 4-bit microcontroller M43C200 family is recommended for low-current applications, as it provides a stop mode for current saving. TEMIC TELEFUNKEN microelectronic offers a customer-specified ROM programming.

In the first chapters fundamental system considerations are given. After the boundary conditions of remote control systems are discussed, we will illustrate and compare the different concepts of RF systems. One main part of this paper is the description of the receiver ICs and design hints for the receiver's IF part. Next measurement results of dc- and dynamic parameters are presented and discussed. The last subject is a proposal for a complete RF remote control system in the UHF range.

2. Boundary conditions of remote control systems

2.1 Comparison infrared versus RF systems

The infrared key for remote controlling of central locking systems in cars is now a standard feature of luxury- and mid-range cars. It will also be offered in the lower vehicle ranges in the near future. For applications in the domestic installation, infrared based remote control systems have also been introduced. IR remote control systems are inexpensive, well experienced and can be easily realized with conventional production techniques. Recently in some areas, low-power radio links are replacing infrared systems. Especially in the car market, RF-based systems offer the advantage of not being affected by dirt, ice and snow. Nowadays, the car's windows are often additionally shaded to reduce excessive heating of the car interior. Unfortunately the shading attenuates the IR transmission of the remote control systems just as much as the emission from the sun.

2.1.1 The infrared system

Common infrared remote control systems use a gallium-arsenide light-emitting diode as transmitter which emits light of 800 nm to 1000 nm wavelength. It is possible to speak of rectilinear propagation. Reflection mainly takes place at visibly reflecting surfaces. Diffraction at edges is restricted to just a few wavelengths and can therefore be neglected here. For this reason, several receiving diodes should be installed to ensure correct operation under various conditions. If appropriate, an omnidirectional receiving diode can be used. Operation of the system is restricted to an area in which the user can see the reaction. Interference may be caused by continuous light from the sun and from the headlights of other vehicles, 100 Hz components of mains-operated incandescent lamps and their harmonics in

the case of gas-discharge lamps. Recently interfering light in the 30-kHz band from modern energy-saving lamps with switched-mode power supply also has to be considered. Spectral components of the data signal within these frequency bands should be avoided by coding.

On the transmitter side, for purpose of current saving, pulse position modulation with an extremely low mark-to-space ratio is used. Operation is done by a single IRED (**I**nfra **R**ed **E**mitting **D**iode) with an extreme directional characteristic. This high directional characteristic of the IRED is a frequent object of customer criticism, since aiming at the target with the key is not accepted.

If we are looking at the receiver, the infrared system is quite simple. A photodiode converts the received light into a current which can then be converted into digital signals by special circuits without a high-power requirement. Higher system costs may result from the use of several receiving diodes due to the increased expense of installation. The costs for the sub-assemblies of the IR system however will always be low compared to the RF system.

2.1.2 The RF system

RF systems operating in the UHF band are not restricted to the line-of-sight coverage of optical systems due to diffraction and reflection of radio waves at edges and conductive surfaces as well as their capability to penetrate dielectric materials. This becomes apparent in an even illumination of space under complicated spatial circumstances as in buildings. Also the necessity to aim with the transmitter at the receiver is removed, because the commonly used small, low-gain aerials show an almost perfect omnidirectional radiation pattern. The range of the RF system can not be well defined because of the mentioned propagation characteristic and due to additional polarization

losses. These may vary from zero up to approximately 20 dB, depending on the relative orientation of the transmitter and the receiver antennas. Nevertheless in most cases, there is a high statistical probability of sufficient field strength.

On the other side, a problem could be the probability of excess range, such as when several conductive surfaces are coincidentally located close to the transmitter or receiver in a way that they form the elements of a parabolic reflector. Wave guidance occurring along conductive planes, for instance in a multi-storey car park, may increase the operation range as well. In this case, a considerable discrepancy between the optical perception range of the user and the range of the transmission link exists. For applications with higher security claims, misuse must be prevented. Listening-in to the radio frequencies with sensitive special receivers appears to be a problem. Average technically-orientated criminal intelligence is sufficient to receive, store and re-transmit a data telegram without changing code. These problems were discussed before when infrared transmission links were introduced, but seemed to be not critical owing to the restricted range and directional effect of the IRED.

If we compare the advantages and drawbacks of infrared and radio frequency systems, it becomes obvious that radio frequency technology helps to overcome some of the restrictions of infrared technology. However, in the last mentioned infrared technology are other problems to solve; so both systems are likely to co-exist.

2.2 Transmission frequencies for RF systems

If a radio frequency based remote control system shall be designed, one of the first decisions is the choice of the operation frequency. The frequency bands that may be utilized for RF-based remote control systems were fixed by the national authorities – therefore they are various for different countries. Nevertheless in most countries similar frequency allocations for remote control systems exist: the short wave band ("citizen band" 27 MHz or 35 MHz to 40 MHz), the UHF band (300 MHz to 450 MHz) and one band around 2.4 GHz. A chart of the ISM frequencies is given in figure 1.

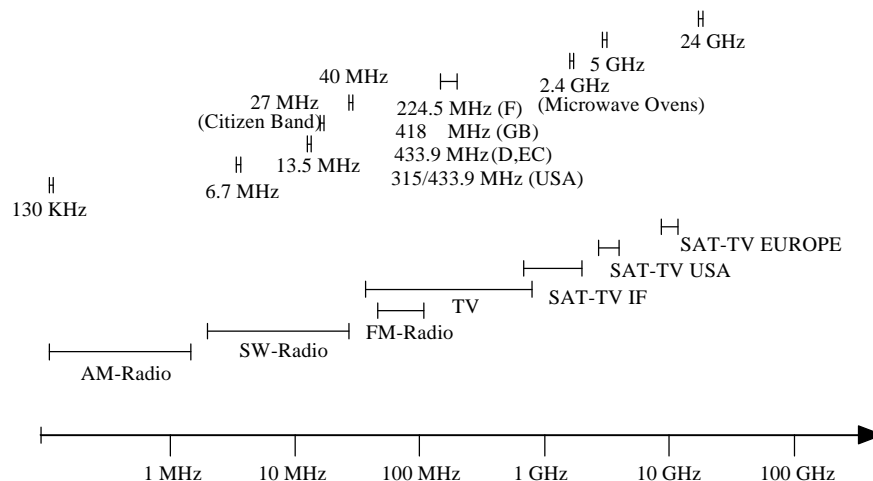

Figure 1 Chart of ISM frequencies

ANT012

At first we regard the short wave band. The advantage of these frequencies is the larger operation distance that can be obtained with a certain transmitter power, as the efficiency of the active components is better than for the higher bands. The layout of the **Printed Circuit Board (PCB)** is less critical, because the parasitic capacitors are small – compared to the used components – and unwanted coupling can be easily avoided. Unfortunately, the required antenna size is the largest of all possible frequency bands. Concerning the relation between antenna size, operation frequency and the received power at a fixed distance, we made a theoretical study, which will be discussed in chapter 10. The radiation characteristic of the transmitter antenna isn't isotropic, therefore the operation range depends on the antenna's orientation. As the frequency range is divided into channels in most countries, the expense for filtering must be high. A great disadvantage is the large number of public services in this band, so that it is rather crowded. To avoid distortions from high-power transmitters, a good large-signal behavior and high selectivity are required.

The UHF band makes the use of rather small antennas possible. Especially a small loop antenna on the transmitter side can be included on a miniaturized PCB. It behaves as a spot radiator, so a quasi isotropic transmitting characteristic is provided. Wave propagation is rectilinear in a first approach, but receiving "round the corner" is possible due to the deflection on metallized edges. The wave propagation along conductive surfaces helps to overcome larger distances, for example in parking garages. For production, conventional techniques can be applied, using discrete active components with high gain and low power-loss. Advantageously, they are **Surface-Mounted Devices (SMDs)**, like the passive components, too. These parts are available in many variations thanks to the TV- and telecom mass production. The PCB layout is much more critical than in the short wave band, es-

pecially if miniaturized solutions are required. In fact, the layout has to be treated as a RF component and requires experience in the production of RF subassemblies.

At last we look at the 2.4 GHz band. In this frequency range for a given transmitter power, the operation range is shorter compared to the UHF band. The reasons are higher free space losses and poorer efficiency of the active components. Due to the absorption by water molecules, these frequencies may be injurious to health and the operation distance is reduced by fog or rain. The production of subassemblies for this band requires special techniques, components are expensive and the degree of integration is very small. With regard to the low efficiency, this frequency range is not suited for low-current applications. An advantage of the 2.4 GHz band is the possibility of transmitting high data rates thanks to the larger available bandwidth.

As a conclusion for small-sized, universal, low-power remote control links, the UHF range seems to be the best choice. In the following chapters we will discuss only applications for this frequency band, although the receiver ICs can be applied for transmission links working at other frequencies too.

2.3 National legal prescriptions

As previously mentioned, the regulations for the operation of RF-based remote control systems are different for many countries. UHF transmission links appeared earlier in the USA, owing to uniform and liberal FCC regulations in a large market. Since a RF transmission link contains an UHF transmitter and an UHF receiver, it becomes a subject of interest for the responsible national authorities. The current European approval practices are not yet uniform and stable. However, uniform trends can be recognized within the scope of EU harmonization. At present time, the EU

guideline ETS 300220 will be transferred by the national governments in Europe into national laws. In Germany, for instance, these new regulations will replace the present standard of Federal German Post Ministry (BMPT) Ordinance 17TR 2100.

One of the prescriptions of the 17 TR 2100 is that the transmitter and the receiver have to be crystal- or SAW-stabilized. The operation frequency in the UHF range must be between 433.05 MHz and 434.79 MHz, maximum radiated power of the transmitter is 25 mW. Harmonics and spurious radiation of the receiver are limited to a value of 1 nW up to 1 GHz and 30 nW between 1 and 40 GHz. In practice, the radiated power of simple transmitters is limited by the maximum values for the radiation of harmonics, otherwise efforts have to be spent for filtering. The typical output power for a single-stage transmitter is below 10 μ W, which corresponds to -20 dBm. The center frequency of the band mentioned above is 433.92 MHz; it is licensed for Europe and all countries of the United States of America. For this reason, we are focusing on this frequency in the following parts.

Nevertheless it has to be considered, that some boundary conditions are depending on national regulations. So in the USA or in Italy for instance, super-regenerative receiver concepts

are allowed and wide-spread. In France, the channel width is much more narrow (only 12.5 kHz). The maximum output power is variable for different countries too.

2.4 Further boundary conditions

If the decision was made towards a radio frequency based remote control system on 433.92 MHz, the legal prescriptions are only one part of the boundary conditions. Other boundary conditions depend on the desired application. For the use in the automotive field, the stringent requirement of the car manufacturers has to be met: the average current consumption of every additional module built into a car must not exceed 1 mA. Additionally, the maximum case size of transmitter and receiver, required operation distance, temperature and humidity range, EMI, ESD as well as shock protection and the reaction time are examples of boundary conditions. The location of the antenna and the subassemblies can cause trouble too. The technical attributes, such as transmitter power and receiver sensitivity, modulation system and coding techniques can be derived from the boundary conditions. Most of these aspects depend on each other and some of them will be discussed in the subsequent explanations.

3. System comparison of RF remote control concepts

The engineer designing a RF-based remote control system has to choose between different concepts, which will be described in the subsequent chapters. To get an overview, let us first look at the block diagram in figure 2. To simplify matters, we consider an uni-directional transmission system. Therefore, we need only one transmitter and a single receiver. Nevertheless, most of the following considerations apply also to multi-directional systems.

Both transmitter and receiver can be subdivided into a digital and an analog section. The digital part of the transmitter encodes the information to a serial bit stream which can be modulated upon a RF carrier. This is done in the RF transmitter unit. Vice versa in the receiver RF module, the serial data signal is recovered and the subsequent decoder makes the transmitted information available at its control outputs.

ANT012

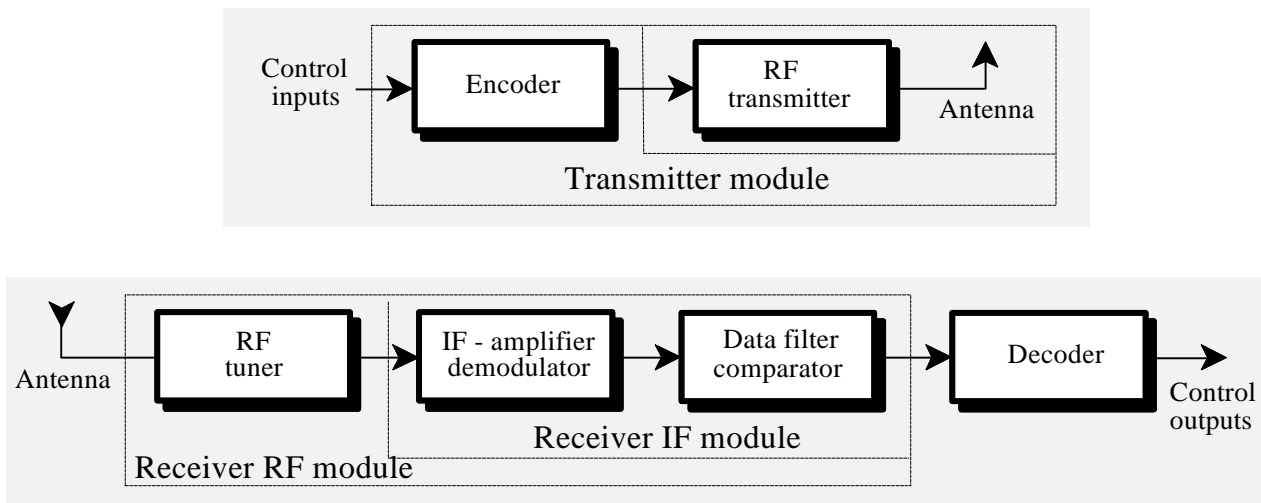

Figure 2 Block diagram UHF remote control system

3.1 Standby versus polling concept

For some applications as in the automotive market, low-current consumption is one of the most important demands on the receiver side. One possibility is the use of a low-current, permanently receiving IC for IF amplification and demodulation, combined with a front end that is dc stacked with the integrated circuit. For those applications, the AM receiver IC U4314B with a total current consumption below 1 mA is provided by TEMIC TELEFUNKEN microelectronic. This integrated circuit will not be discussed in this paper, for further information a data sheet is available.

More complex ICs require higher supply currents, but a lower average supply current can be obtained by standby or polling concepts, which are explained subsequently.

The standby concept minimizes the current consumption of the receiver by utilizing the fact, that some functions are not permanently required. Therefore, two receiver modes exist. First in the standby mode, only those parts are turned on which are needed to detect the presence of a relevant signal, and if necessary to switch the receiver to the active mode. In this

second mode, the remaining components, which are needed for further signal processing, are enabled and current consumption is consequently increased. The advantage of this concept is the short reaction time. As soon as the input level exceeds the "wake up level", the switching is carried out virtually without any time delay. To ensure that the receiver will not be permanently in the active mode, the wake up threshold has to be far above the limiting sensitivity of the active mode. This is a disadvantage because one can't profit of the receiver's absolute sensitivity.

On the other side, it has to be taken into account that a decoder, receiving permanently a random bit sequence, will sometime detect a valid telegram. The statistic probability of such an event, caused by noise, interference or similar signals, increases with the frequency and duration of the times, when the receiver is in the active mode. The wake up concept therefore helps to reduce redundancy in the transmitted code.

In a polling concept, the switching of the receiver between sleep mode and active mode is externally controlled. A low-current microcontroller switches the receiver periodically for a short time to the active mode and looks for the occurrence of valid data. If such data are detected, the microcontroller causes the receiver

to remain in the active mode, until the complete data telegram is received or no more valid data packets are received for a defined time. For this reason, the active time has to be long enough to decide whether the signal contains valid data. Obviously, the benefit of the polling mode is the better sensitivity, because no separate wake up level is needed beyond the receiver's active mode limiting sensitivity. A drawback of this concept is its longer reaction time, which depends on the switching rate. As the duty cycle between sleep times and active times is determined by the required average supply current and the active times can't be reduced to any desired value, the reaction time is longer by principle.

Summarized, the decision for one of these concepts depends on the degree of importance of reaction time and sensitivity. TEMIC TELEFUNKEN microelectronic GmbH provides receiver ICs covering both conceptions.

3.2 Superheterodyne or superregenerative receiver

The integrated circuits U4311B and U4313B support a superheterodyne receiver concept with an average current consumption of approximately 1 mA. A new special device is the U4314B, which supports an AM receiver with a total supply current below 1 mA. The front end for those receiver concepts typically consists of an input filter, one or two preamplifier stages, a local oscillator and a mixer stage. The oscillator and the mixer may be combined to a single stage. The front end converts the modulated RF down to an Intermediate Frequency (IF) of 10.7 MHz, which passes a filter and is supplied to the receiver IC. Technical details will be discussed in the following chapters.

The superheterodyne concept is well-known from the FM radio receivers, where it has proved its good performance with regard to sensitivity, selectivity and large-signal behavior.

Radio specialists and technically informed radio listeners are aware of image frequency reception and cross modulation. These aspects are also significant for a remote control receiver. In practice, the field strength required for interference can be expected only in the proximity of strong transmitters, but they will then restrict the system range. Amateur radio must be taken into account at a frequency of 433.92 MHz, because the same frequency is primarily used here as well. The harmonics of VHF-range television transmitters, the mobile phone network and, slightly apart, television band IV are all close to 433.92 MHz. These potential sources of interference do not seem to be critical compared to the influences, a remote controller in the short wave range for instance has to expect. Nevertheless, high selectivity is required

Radiation of the receiver may appear at the local oscillator's frequency, which is located 10.7 MHz beside the RF input frequency. It can be easily suppressed by the preamplifier and the input filter. The IF of 10.7 MHz was chosen as it is a well experienced technology and low-cost components from the radio production are available with many different specifications. The receiver ICs take over the signal processing until the data output, as an operational amplifier and a clamping comparator are included for base band filtering and data shaping. The U4311B and the U4313B are suited for AM- as well as for FM demodulation.

One drawback of the superheterodyne concept is the comparatively high expense, but fortunately the whole processing from the IF input to the data output can be managed by one integrated circuit of TEMIC TELEFUNKEN microelectronic GmbH. Image frequency reception is a typical shortcoming of a superheterodyne receiver, in our case it's the reception on the frequency 423.22 MHz minus 10.7 MHz. To achieve a good image rejection, the bandwidth of the input filter and the preamplifier has to be narrow enough.

ANT012

If the requirements regarding the receiver radiation are not too strict, a superheterodyne receiver is not the only possible concept. A superregenerative receiver is more simple and, as a consequence, cheaper than a superheterodyne receiver. A superregenerative concept doesn't use any intermediate frequency. The modulated RF is directly converted to the base band by means of a periodically oscillating transistor stage. As the oscillation frequency is the same as the received frequency, the radiation of the receiver can't be reduced by a simple input filter. The selectivity and by this the rejection against out of band interferences is worse, because there is no additional filtering like in the superheterodyne's IF band. Another drawback is the mediocre large-signal behavior. Especially in low-current concepts, the oscillations of the receiver transistor may be intermitted by a strong input signal. Using amplitude modulated systems, for data transmission commonly applied with a modulation depth of 100%, the rise time of the receiver limits the data rate to a few kBaud.

In summary, a superregenerative receiver is a cheap alternative for low data rates and low-performance AM applications. The legal prescriptions regarding the receiver radiation have to be fulfilled. For all other applications with higher requirements to the system's performance and for FM operation, the superheterodyne concept is superior. For narrow-band operation, as it is prescribed in France, it's the solution without alternative.

3.3 Comparison AM- and FM operation

A remote control link with a superheterodyne receiver offers the possibility to use amplitude modulation as well as frequency modulation. AM operation is more simple to realize, especially with regard to the transmitter design. The achievable sensitivity referred to a certain bit

error rate is – for the TEMIC TELEFUNKEN system – comparable to FM operation with small frequency deviation.

The most simple solutions sometimes have drawbacks. If a cheap single-stage transmitter is used, the obtainable data rate is limited to a few kBaud. This fact results from the comparable long transient time of the transmitter, when it is completely turned on and off. However, for several applications, as keyless entry systems for instance, such transmission rates are sufficient. To achieve a high average transmitter output power, it is advantageous to apply a special coding technique with a mark-to-space ratio shifted close to one. Amplitude modulation doesn't work as noise suppressive, therefore interferences are stronger compared to an FM system. This effect is known to every radio listener as the audible difference between VHF and medium wave reception.

FM operation allows higher transmission rates due to the shorter transient times. Therefore, FM operation is the better choice for semi-duplex transmission. It is open for future developments, which will probably require higher data rates. The transmitter works at its maximum power during the whole transmission, so that the average output power is higher compared to AM transmitters. The continuous transmission further gives a better compatibility with existing infrared systems, so that the same coding may be used. Frequency modulation exploits the system's bandwidth much better than amplitude modulation, therefore it is able to reduce interference, if the modulation index and herewith also the bandwidth is matched. However, it is not easy to achieve high frequency deviation with rather simple, SAW-based transmitters.

A benefit of our concept is the low additional expense of the FM- versus the AM receiver: only a discriminator filter and two resistors have to be added.

4. The TEMIC TELEFUNKEN receiver ICs U4311B, U4313B, U4314B

For a more detailed description of our remote control system, we have one more look on figure 2. At first, the receiver IF part will be discussed. As the ICs of the U431xB family are the essential components, their main features are listed below.

- Wide supply voltage range
- Suitable for battery operation
- AM- or FM operation mode (U4314B only AM)
- Low-current consumption by the use of a standby- or polling concept (with U4314B the total current consumption is below 1mA)
- With exception of U4314B included high performance operational amplifier and clamping comparator for data filtering and shaping

A short description of these integrated circuits

is given subsequently, table 1 shows a survey of their different and common features. The integrated circuits U4311B-C and U4313B include the following functions:

- IF amplifier
- Logarithmic AM demodulator
- FM demodulator
- Wake up circuit with mono-flop
- Operational amplifier
- Data comparator, non-inverting type for U4311B-C, inverting type for U4313
- Voltage regulator

The only difference between these two ICs is the polarity of the data output. The U4314B is an AM receiver without baseband processing. For technical data and further informations concerning the receiver ICs please consult the data sheets.

ANT012

Common features:
Wide supply voltage range: 3 V to 12 V
IF amplifier, U4311B-C, U4313B including operational amplifier to realize data filter and clamping comparator for data shaping, with serial data output for external data processing
Stabilized reference voltage 2.4V, externally available
Quiescent current approximately 1mA

Differences:			
Feature	U4311B-C	U4313B	U4314B
16-pin DIP / SO package	X	X	-
8-pin SO package	-	-	X
Included wake up circuit, switches the IC to the active mode in case of sufficient IF input level or an externally applied control signal (additional polling)	X	X	-
Permanent receiving with a total supply current below 1 mA	-	-	X
Inverting clamping comparator	-	X	-
Non-inverting clamping comparator	X	-	-
AM operation/ RSSI output	X	X	X
FM operation	X	X	-

Table 1 Survey of remote control receiver ICs U4311B-C, U4313B, U4314B

For the following explanations of the receiver's IF part, we assume that the U4313B is used. In principle, these informations can be transferred also to the other ICs. A block diagram, showing the IC's internal parts and the external components of the complete receiver, is shown in figure3.

The 10.7 MHz IF signal from the front end passes the integrated IF amplifier, which operates for amplitude- or frequency-modulated signals to either a logarithmic AM demodulator or a quadrature detector for FM. The logarithmic AM demodulator was implemented to

avoid settling time problems effected by use of an amplifier with automatic gain control in the IF section. A data shaping filter – advantageously realized with the internal high performance operational amplifier – reduces system bandwidth to an optimized compromise regarding noise reduction and data rate. Thus an optimal bit error rate can be achieved without any further additional active components. A brief description of various data filter designs follows in chapter 5.

The comparator connected to the output of the filter has a level-dependent hysteresis and

clamps its reference voltage to the signal minimum and maximum peaks as described later.

Without IF input signal – in the sleep mode – beside the bandgap reference and the wake up circuit, only the IF amplifier and the AM demodulator which operates as a **Received Signal Strength Indicator (RSSI)** are activated. If the level of the IF signal increases, the whole circuitry is turned on by the wake-up circuit. This signal is externally available at pin 10, which switches to low level in the active mode. As the wake up output is supplied with an open collector, its high level depends on the voltage to which it is connected. So this output is suitable to switch external components like a microcontroller by applying a control signal with standard TTL level. After an adjustable hold time, determined by the wake up time constant at pin 3, the integrated circuit rests down to the sleep mode. In this case, 1 mA

supply current is required. An external resistor matched at pin 3 to ground blocks the wake up circuit and gives full function at lower IF level, but supply current increases up to typically 3 mA.

The output signal of the operational amplifier is fed to the input of the inverting comparator. Its time constants are adjustable by RC+ and RC- and must be adapted to the transmission code and the data rate. The time constant should be large, compared to the data rate for optimized noise- and hum suppression. The difference of the peak values controls the hysteresis, their mean value is used as comparator threshold. This clamping comparator works as a data regenerator.

In the subsequent chapter the results of dc-based and dynamic measurements on the receiver ICs are presented and discussed. These explanations shall complete and deepen the measurement results given in the data sheets.

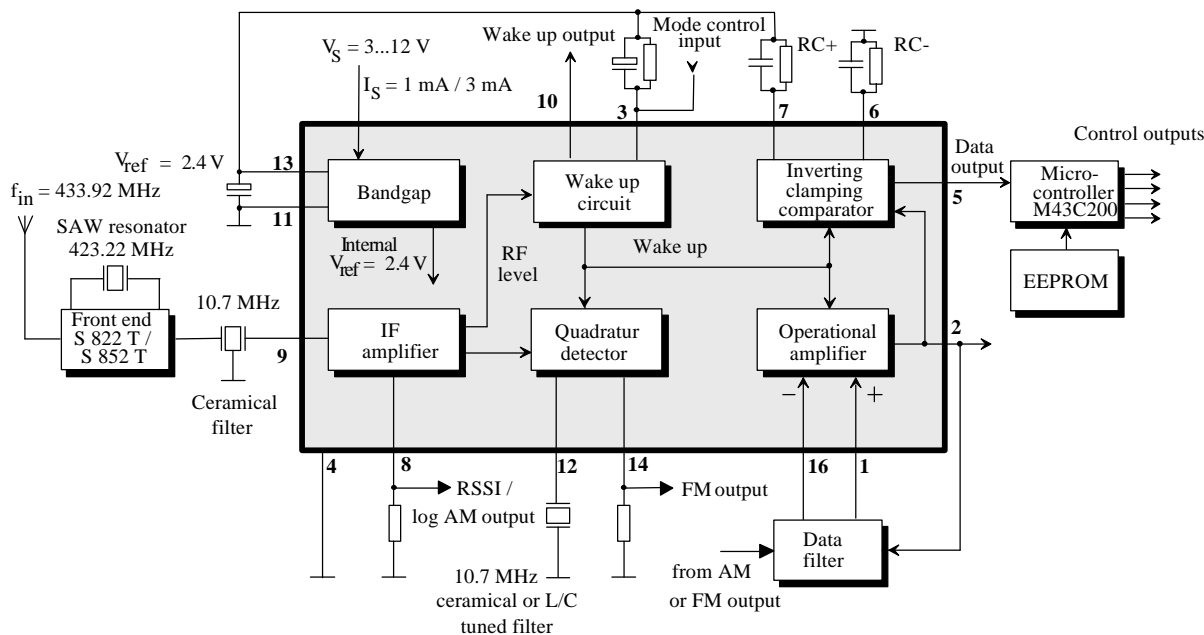

Figure 3 Block diagram of the receiver IC U4313B

ANT012

4.1 DC parameters of the receiver ICs

For purpose of measurements on the receiver ICs, testing and adapting to certain applications, a printed circuit board is available. This PCB contains the complete signal processing from the IF input to the data output. The circuit diagrams are given in figures 31, 33 for AM respectively figures 35, 37 for FM applications of U4311B-C/ U4313B. The placement of the components can be found in figures 32, 34 and figures 36, 38. Figure 30 shows the layout of the universal PCB. These circuit diagrams represent the actual application circuits.

If not marked otherwise, all statements and the component numbers are referred to these IF test circuits. The component values are application-minded and may deviate from those circuits published in the data sheets. A principle dc measurement setup is given in figure 4, showing the external connections of the IF board to the measurement equipment. The

data generator and the level shifter are not necessary for the dc measurements, which are discussed within this chapter.

The electrical characteristics of the integrated circuits are nearly independent of the supply voltage, as the internal functional blocks are referred to the bandgap stabilized voltage. This applies also to the supply current of the IC as it can be seen in figure 5, which shows the typical dependence of the supply current from the supply voltage for the U4313B.

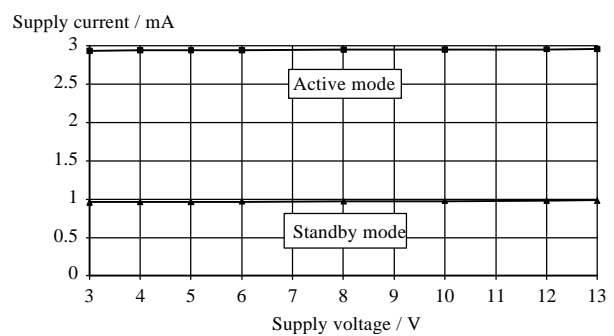

Figure 5 Supply current of U4313B versus supply voltage

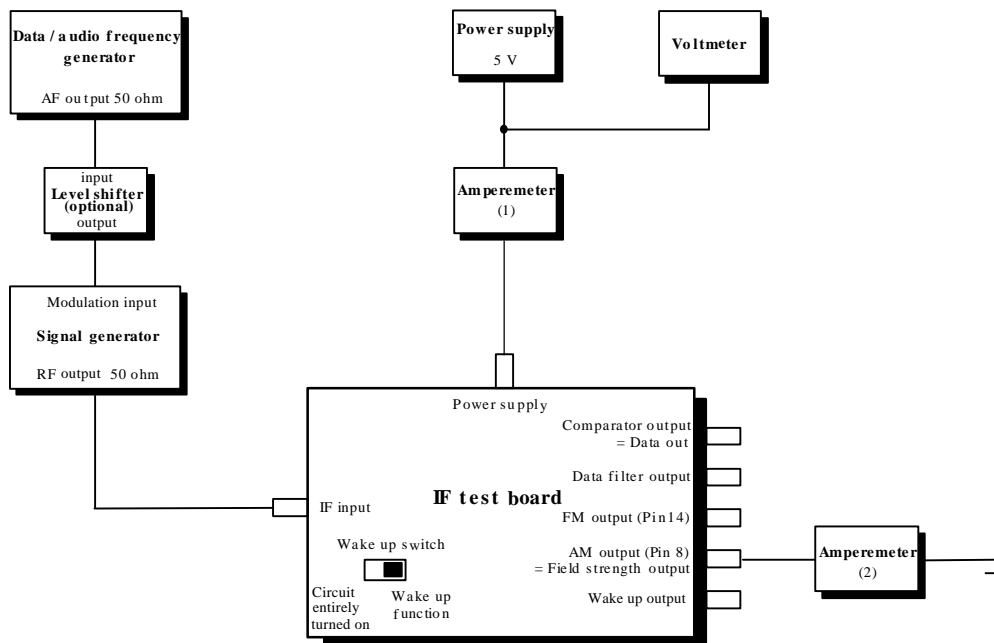

Figure 4 Setup for measurement of dc parameters

The switching between passive and active mode can be controlled by the wake up switch, with the IF input of the test board disconnected, so that no signal generator is necessary. Another possibility is to apply an unmodulated IF signal with levels above and below of the wake up threshold, while the wake up switch is in "wake up function"- position. The output voltage of the power supply is shifted from 3 V to 12 V to cover the whole supply voltage range. For this measurement, the amperemeter (2) shown in figure 4 has to be disconnected, otherwise the current out of the AM output would increase the total supply current.

The receiver ICs U4311B-C and U4313B provide an internal wake up circuit with a fixed threshold. The wake up threshold of the receiver ICs, that means the required IF level for switching the IC from sleep mode to active mode, is almost independent of the supply voltage and temperature. A variation of supply voltage over the total range from 3 V to 12 V causes a variation of the wake up threshold of less than 0.5 dB. This means that the sensitivity of the receiver IC is nearly independent of the supply voltage.

As the IF input of the integrated circuit family U431xB provides an input impedance of approximately $R_{in} = 330 \Omega$ to match directly a ceramic filter, the resistors R 9, R 10 are needed for the transformation to the 50Ω IF input resistance of the test board. The voltage loss caused by this circuitry can be calculated as follows:

$$L / \text{dB} = 20 \lg \frac{R_{in}}{R_{in} + R_{10}}$$

With the actual values of the resistors the loss is approximately -5.6 dB.

So a voltage level of $40 \text{ dB}\mu\text{V}$ at the IC's IF input pin 9 corresponds to a voltage level of $45.6 \text{ dB}\mu\text{V}$ at the input of the test board and with this also at the output of the signal gen-

erator. The IF level can be measured either directly at the IC's input pin with a RF millivoltmeter or a spectrum analyzer, or the measurement is referred to the IF input of the test circuit which will be the method for all further measurements published within this paper. Please don't confound these different values with each other.

The increased current consumption of the IC can be used as a criterion for being in the active mode. Another criterion is the logical state of the wake up output. A high level indicates the sleep mode, so consequently the active mode is marked by a low level. As the wake up output is supplied with an open collector, its high level depends on the voltage to which it is connected.

4.2 IF frequency response

The ac parameters of the receiver IC include measurements of signal-to-noise ratios, demodulator characteristics for AM and FM, the frequency response of the data filter and bit error rate measurements. All these subjects will be discussed in separate chapters. Within this section we will merely have a look on the frequency response of the IF amplifier. As for the two possible transmission systems (AM or FM) the IF signal is processed by the same IF amplifier, its characteristic influences all applications. The amplifier works without any gain control circuit.

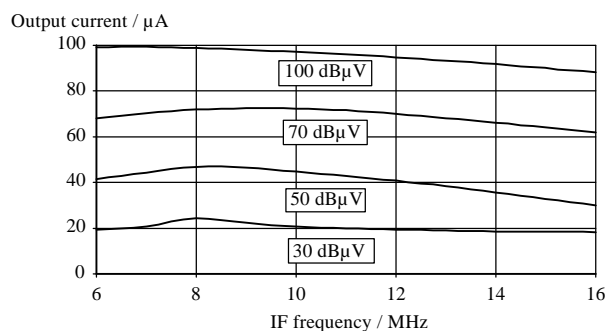

Figure 6 Frequency response of the IF amplifier

ANT012

The measurement configuration according to figure 4 is used. The frequency of the unmodulated signal generator is swept, applying various IF levels to the test board. The dc current from the AM output pin 8 to ground is measured with amperemeter (2) while the data filter

is decoupled. The diagram in figure 6 shows the level depending internal characteristic of the receiver ICs. As it can be seen, the IF amplifier is a broadband type with a slight band pass characteristic.

5. Data filter and data regeneration

Another subject, which concerns AM- as well as FM operation, is the base band filter for data regeneration. The optimal matching of the data filter to the used code has a great influence on the system performance, e.g. the achievable operation distance. Therefore, the following chapter is completely dedicated to this item, based on profound investigations on different filter types.

The following design hints may give some assistance, using the implemented operational amplifier of U4311B-C / U4313B as an active data filter.

In order to minimize distortions caused by the filter's settling time, a Bessel- or Butterworth type filter is proposed. The bandwidth of the data filter should be kept as low as possible to obtain low noise at the output. Transmission rates of about 1 kBaud to 2 kBaud seem to be adequate for many applications, in case of a 0-1-0-1 sequence this corresponds to a frequency of 0.5 kHz to 1 kHz. Therefore, a cut-off frequency of 2 kHz is sufficient for the low-pass filters of second order discussed subsequently.

5.1 General

Two types of filters were investigated. The first one is ac-coupled and therefore recommended for manchester code, that means a code free of dc component. The second filter is quasi dc-coupled to the demodulator's output stage and provides advantages, if a coding with a significant dc component is chosen. An example is a code with a long start burst,

usually applied for IR transmission and in RF/AM-systems. "Start burst" means an impulse at the beginning of the data transmission, which is much longer than the data bits. It is not to be mixed up with the "start bit", which marks the beginning of a data telegram. In case of such coding, the value of the filter's coupling capacitor increases. Especially for FM operation, no electrolyte capacitors can be used, because the polarity depends on the tolerance of the IF frequency (above or below the center frequency of 10.7 MHz) and the instantaneous value of the data signal. To avoid the higher costs and the bigger size of a large capacitor, we recommend the quasi dc-coupled data filter. Thereby, the same frequency response can be obtained with smaller capacitors. Both filters achieve the same results of input sensitivity for a given maximum **Bit Error Rate** (BER), as will be shown later in figures 17, 18.

For applications using the polling mode of the IC, one of the most important parameters is the reaction time, because it determines the timing of the polling, that means the minimum active time. For this reason, the transient time of the IF board was examined. For the quasi dc-coupled filter for FM operation according to figure 37, a transient time of 40 μ s was measured. This means, that if a data signal is transmitted permanently, there will appear valid telegrams at the receiver's data output 40 μ s after the receiver is switched to the active mode. Only the very first bit received in the active mode might be undefined if it's a high-bit. The transient time of the corresponding

filter for AM mode according to figure 33 is approximately 25 μ s. As the transient times are much longer for the ac-coupled filters - dependent on the coupling capacitor C 2 and the voltage gain between 30 ms and 150 ms - the dc-coupled filter is recommended for polling concepts. To figure out the filter transient time, the wake up time constant has to be set to the minimum value by removing the capacitor C 5.

In order to achieve a well-defined operating point of the circuit, the operational amplifier can't be directly dc-coupled to the FM- respectively the AM output, due to the various bias voltages at corresponding pins. For this reason an additional high-pass filter characteristic is implemented. The voltage gain of the filter should be in the range of $|A| = 3$ to 10 for FM, as the demodulator's output voltage is comparably large and nearly independent of the IF input level. The optimum value of the voltage gain depends on the gradient of the FM characteristic. For AM systems $|A| = 10$ to 30 is recommended, because at low IF input levels, the gradient of the AM characteristic and therefore also the demodulator's output voltage swing is very small. The value of the demodulator's output voltage depends on R 11. The dimensioning for the filter's voltage gain has been optimized in practical examinations. Due to the high gain bandwidth product of the internal operational amplifier, it can be treated as ideal for data rates up to several 10 kBaud. The input impedance of the data filter is determined by the resistance of the FM- respectively the AM output. For calculations, the internal output resistance as well as the external resistors have to be considered. The AM demodulator is a current source, therefore only the external resistors are significant; the impedance of the FM output is 50 k Ω . According to the test circuits figure 31, 35, 37, the total resistance is approx. $R_i = 10$ k Ω for FM- and AM operation, according to figure 33 it is 15 k Ω for AM. As it is less sensitive against unwanted feedback, an inverting filter is cho-

sen. For designing an active Bessel type, data filter, PC programs or filter handbooks may be used.

To dimension an active second-order Bessel type low-pass filter as it is used in the test circuits, the following formulas may be helpful, according to reference [1]:

$$R_2 = -A \cdot R_i \quad (1)$$

$$C_3 = \frac{1.362}{\left(R_1 + R_2 + \frac{R_1 \cdot R_2}{R_i} \right) \cdot 2 \cdot \pi \cdot f_c} \quad (2)$$

$$C_1 = \frac{0.618}{R_1 \cdot R_2 \cdot C_3 \cdot 4 \cdot \pi^2 \cdot f_c^2} \quad (3)$$

In these formulas, A means the (negative) voltage gain of the low-pass filter, f_c is its cut-off frequency, R_i is the output impedance of the demodulator, R_i can be set to an arbitrary value.

Data filter and comparator time constants design is custom specific, matched to the data telegram. TEMIC recommends to carry out the dimensioning of the filter and comparator components using IF test signals. For this purpose, the IF test board may be used. Criterion is the sensitivity for a given maximum bit error rate (BER), as described in chapter 5.5 of this paper. Depending on the mark-to-space ratio of the coding, best results may be obtained with different values of R 4 and R 12, so that the clamping comparator gets an asymmetric characteristic.

The receiver ICs U4311B-C and U4313B-C are similar with exception of the data output polarity. U4311B-C includes a non-inverting and U4313B an inverting clamping comparator. Therefore, the operational amplifier can be used either as a non-inverting or an inverting filter without the need of any more components. Further, an optimal adaptation to the microcontroller input polarity doesn't require additional expense.

ANT012

5.2 AC-coupled data filter

The most simple way to achieve an additional high pass characteristic is the ac-coupling between demodulator and filter. The following example of dimensioning, the data filter and the comparator's time constants have been optimized for a Manchester code with a long start burst of about 8 ms and a transmission rate of 1 kBaud to 2 kBaud. The high-end cut-off frequency of the filter is $f_c = 2$ kHz, the voltage gain is $A = -5$. The filter is matched to a demodulator output resistance of $1\text{k}\Omega$.

- $R_1 = 15\text{ k}\Omega$; $R_2 = 51\text{ k}\Omega$; $C_1 = 5.6\text{ nF}$;
- $C_2 = 1\text{ }\mu\text{F}$; $C_3 = 820\text{ pF}$; $C_6 = 1\text{ }\mu\text{F}$;
- $C_{12} = 1\text{ }\mu\text{F}$

The position numbers of the components correspond to the test circuits figure 31, 35.

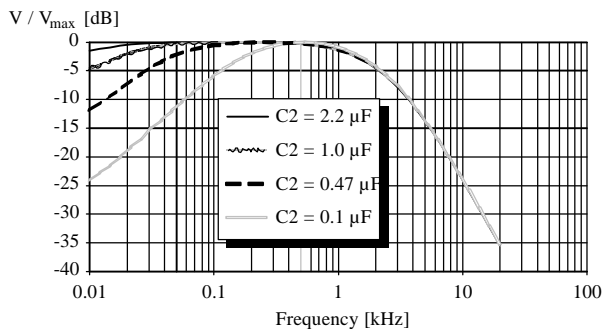

Figure 7 Frequency response of 2 kHz Bessel low-pass data filters with ac-coupling

The frequency response of the data filter and the influence of the coupling capacitor C_2 is drawn in figure 7. Obviously, for codes with a long start burst, the value of C_2 increases. The filter rise time is as mentioned before between 30 ms and 150 ms typically. Therefore, the quasi dc-coupled filter should be preferred. Nevertheless, an ac-coupled filter is suitable for smaller filter bandwidths and for the realization of filters with a real band pass characteristic (for example by substitution of C_1 and C_3 by resistors and R_1 and R_2 by capaci-

tors). Those filters might be used especially for manchester codes with higher baudrates, as 10 kBaud or more. A more broadband filter with a small cut-off frequency at the low end would noticeable increase noise.

5.3 Quasi dc-coupled data filter

For conventional IR- and AM transmission systems, a start burst is necessary to control the receiver gain (AGC) during this time of full transmitter output power. In the TEMIC system, such a start burst is not needed due to the wide dynamic range of the IF amplifier and the logarithmic AM demodulator respectively the signal limiting in the FM mode. Nevertheless, the start burst can be used to assure compatibility with existing transmission schemes, e.g. of former systems. If the wake up concept is used, the start burst can fill out the wake up time of the receiver.

For those applications and for the polling method, we recommend the quasi dc-coupled filter. The principle circuit diagram is given in figure 8, the complete diagram and the values of components are shown in figure 33, 37. The filter is optimized for codes with long start bursts and a transmission rate of 1 kBaud to 2 kBaud. The main difference is the connection of the operational amplifier's non-inverting input to the demodulator output by means of a RC link.

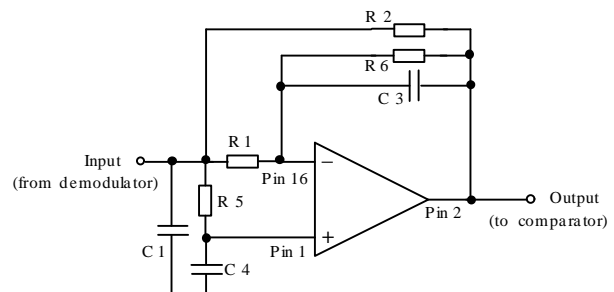

Figure 8 Principle circuit diagram of the quasi dc-coupled data filter

The cut-off frequency at the low end is determined by the time constant $\tau = R_5 \times C_4$ of this RC link. As the impedance of the non-inverting input is high, a large resistor may be coupled with a small capacitor and nevertheless a very low cut-off frequency can be achieved. The remaining filter network is of the same type as the ac-coupled one. For purpose of achieving a well-defined mean operating point, the resistors R5 and R6 are used. These resistors ensure that the offset voltage between the inverting and the non-inverting input of the operational amplifier is limited. For AM operation, due to the operational amplifier's common mode input voltage range of 0.7 V to 1.7 V, additionally the AM output voltage is limited to the same range by means of the resistors R11 and R16.

The frequency response for two examples of quasi dc-coupled data filters are shown in figure 9. According to the circuit diagrams fig-

ures 37, 33, a 2 kHz low-pass filter for FM mode ($R_1 = 10 \text{ k}\Omega$) and a 4 kHz low-pass filter

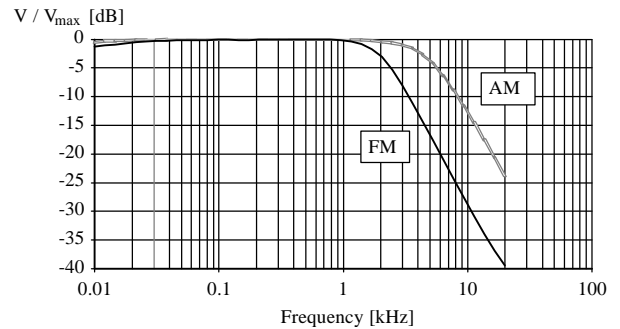

Figure 9 Frequency response of low-pass data filters with quasi dc-coupling

for AM mode ($R_1 = 15 \text{ k}\Omega$) are chosen. The rise time of the IF part for the AM mode is typically 25 μs , for the FM mode it is approximately 40 μs . As it can be seen, the cut-off frequency at the low end is below 10 Hz. The voltage gain was set to $A = -25$ for AM operation and $A = -10$ for FM.

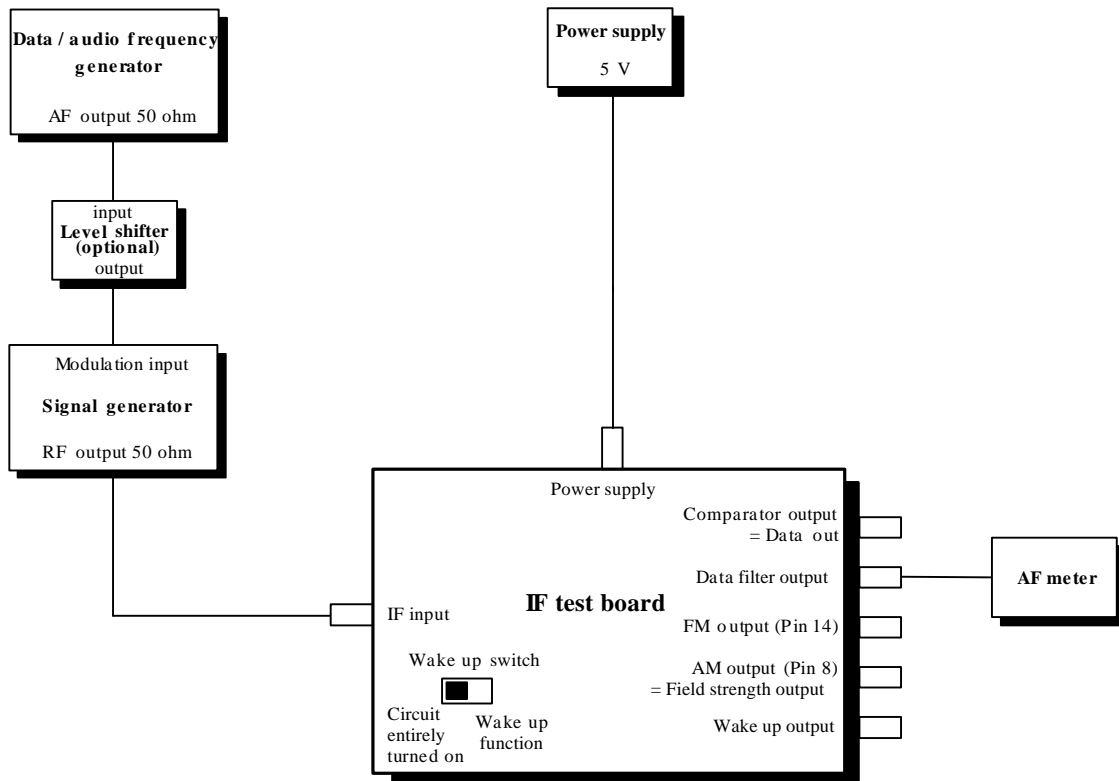

Figure 10 Setup for measurement of the data filter's frequency response

ANT012

The measurement setup to evaluate the data filter's frequency response can be seen in figure 10. Dependent on the type of signal generator, the level shifter may be necessary to adapt the audio frequency generator to the modulation input of the signal generator, so that the desired modulation depth respectively frequency deviation is achieved. It has to be ensured, that the carrier output power is constant for all kinds of modulations, that means, the modulator must be clamped to the "high-level" of the modulation signal (same conditions like TV-signal transmission for example).

The audio frequency generator produces a sine wave, which is swept from 10 Hz to 20 kHz. At the data filter output, the ac voltage level (RMS) of the signal is measured. Modulation depth or deviation should be set to a value of 30% or 7.5 kHz respectively to avoid clipping effects due to the limited dynamic range of the operational amplifier. For our measurements an IF input level of 50 dB μ V was chosen. Please notice that for data transmission the dynamic range of the operational amplifier is without any effect, as the subsequent clamping comparator is used for data shaping.

5.4 Eye pattern

As it has been mentioned, the data filter has to be matched to the used data coding. Therefore, we must have criterions to decide whether we succeeded in optimizing the data filter. Two methods are well-suited for this purpose: the analysis of the eye pattern or the measurement of the bit error rate. The first method will be discussed within this chapter, the second method is explained thereafter.

Let us first get familiar with the expression "eye pattern". If a random sequence of bits is applied to the input of a transmission channel that is band-limited, the data at the output of the systems won't be of rectangular shape. In our case, the input is that one of the IF board,

the output signal appears at the data filter output. Of course this method is also suitable to test a complete transmission link. An oscilloscope is connected to the system's output, while it is triggered by the clock pulse of the data generator. Figure 11 shows the measurement setup. The oscilloscope will display some kind of "eyes", which are the result of the temporal superposition of different sequences at the data filter's output. This is the signal, which must be converted to a digital bit stream by the comparator. A picture of the scope screen with the eye pattern of the system can be seen in figure 12.

With the eye pattern, one can assess the signal quality, it gives basic information about the amplitude- and phase response of the system. Most important is the open area of the eye. The horizontal width characterizes, how critical the moment of sampling is, and the vertical size is a criterion of the uncertainty of the sampled amplitude. The optimal area of decision, whether a certain bit is high or low, is located in the middle of the eye opening.

As long as the eye is not completely closed, there is a chance for data regeneration by means of a comparator. So a rather simple way of optimizing certain parts of a transmission system is the tuning to a maximum eye opening at the desired threshold sensitivity. As the results can be watched simultaneously on the scope screen, this method is well-suited for the fine adjustment of components.

The shown diagram is measured at an input level of 45 dB μ V, which corresponds to the wake up threshold of the receiver. One can see, that the eye is almost perfect open, the signal quality is therefore very good.

If the complete baseband signal processing functions are dc-coupled, the optimal threshold of a binary decision element is the mean value of the low- and the high bits' amplitude. This applies as long as no interference is present. In an ac-coupled system, in particular the transmission of many successive equal bits

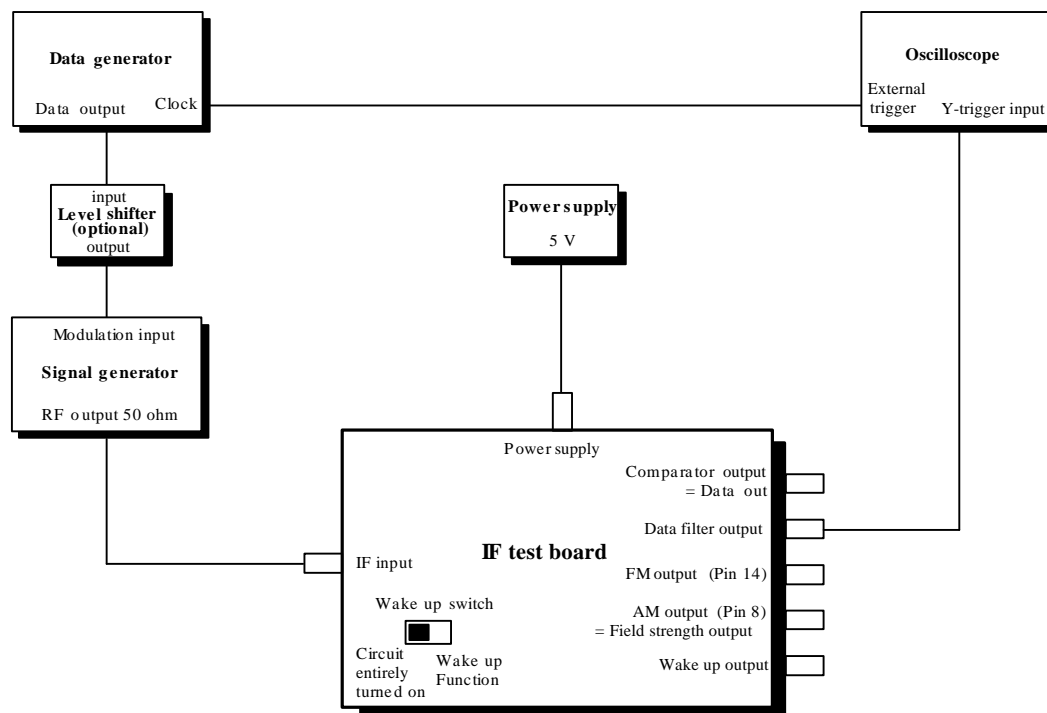

Figure 11 Setup for examination of the eye pattern

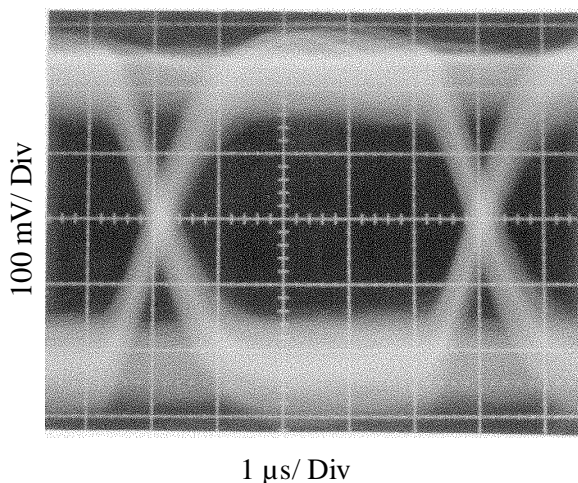

Figure 12 Eye pattern of the UHF remote control system, data rate is 1 kBaund

leads to a so-called baseline wandering in the decision element, what means that the optimal threshold shifts. The amount of this baseline wandering depends on the low-end cut-off frequency in proportion to the ratio of data rate to number of successive equal bits. Therefore, the use of a simple 0-1-0-1 sequence as a test signal does not reveal the real performance of the system.

For this reason, usually a **Pseudo Random Sequence (PRS)** is used as a data signal for eye pattern measurements. This is a sequence of a given length of 2^n-1 bits which is transmitted periodically. Such pseudo random sequences can be generated by means of a back-coupled shift register.

The distribution of the bits in the sequence is quasi random and the maximum number of successive equal bits is n . The probability for the occurrence of the low- and the high bit is almost equal but never identical, because the sequence has an odd number of bits. The largest number of successive equal bits is identical with the exponent n in the formula 2^n-1 determining the length of the sequence. The longer the PRS, the more the spectrum extends to lower frequencies. The length of the PRS must therefore be chosen according to the maximum number of successive equal bits, which are expected in the real used data signal. If a certain way of coding shall be tested, the PRS may be encoded before applying it to the transmission system.

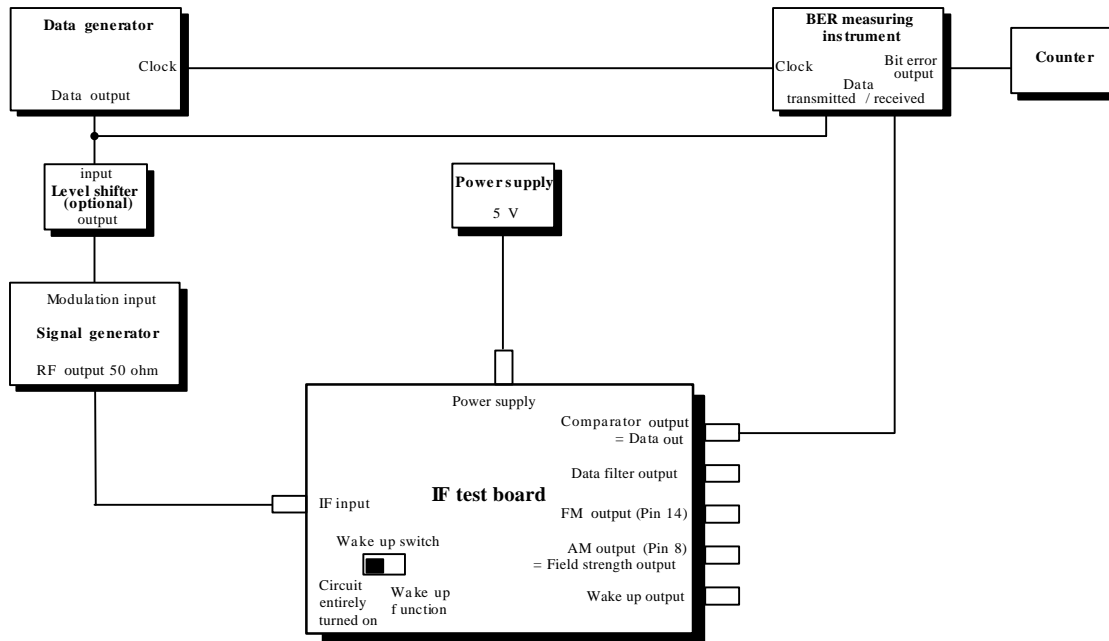

Figure 13 Setup for BER measurements

5.5 Bit error rate measurements

Another possibility to judge the quality of a transmission link is to measure the **Bit Error Rate (BER)**. The BER indicates the probability of a wrong bit at the output of the receiver. At systems with a limited bandwidth (what applies to every real system), the BER depends on the transmitted bit stream. In systems with bandpass characteristic, not only the data rate is limited by the system's high-end cut-off frequency but also the low-frequency cut-off is important. The latter limits the maximum number of successive equal bits. Therefore, also for purpose of BER measurements a pseudo-random sequence is recommended. The measurement setup is given in figure 13.

The original data signal and the clock pulses are applied to the BER measuring instrument, together with the received data from the comparator output of the IF test board. The BER measuring instrument compares the transmitted and the received data at certain decision times,

that are derived from the clock pulse. For this purpose, the transmitted data and the clock pulse are time-delayed inside the measurement unit, so that they are fitting to the received data. If the two bits which are compared are not equal, the measurement unit generates an impulse at its bit error output, which is applied to a counter. The bit error rate, f_e , can be calculated from the number of errors, n_e , the transmission rate, f_t , and the counter's gate time, t_g , as follows:

$$f_e = \frac{n_e}{f_t \cdot t_g}$$

Alternatively, a second counter at the clock output may be used to determine the number of transmitted bits. Then the BER can be calculated by a simple division of the number of bit errors by the number of transmitted bits.

It is a little disadvantage of the introduced method for BER measurements, that it doesn't reproduce the conditions of reality exactly. A real transmission system has to derive the clock pulse and the decision time from the received signal. This will increase the real BER

compared to our measurement setup, where the clock signal is applied separately. But the proposed BER measuring instrument can be easily realized with off-the-shelf TTL gate circuits and it has proved to be a good

estimation for real transmission systems. A block diagram of the measurement unit is given in figure 14, the complete circuit diagram in figure 15.

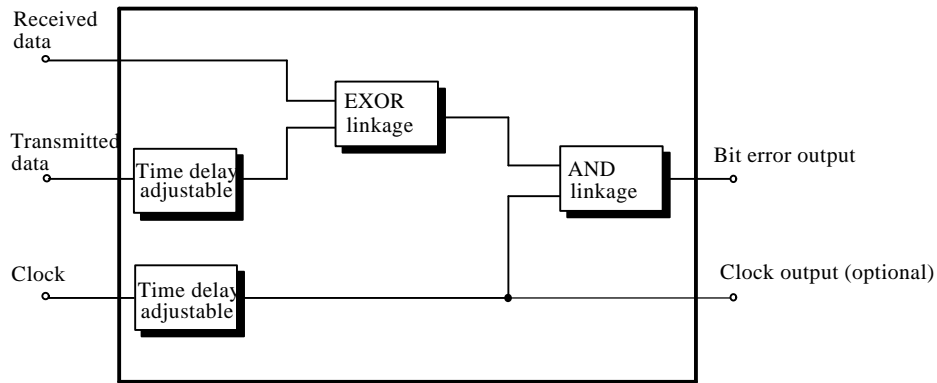

Figure 14 Block diagram of the BER measuring instrument

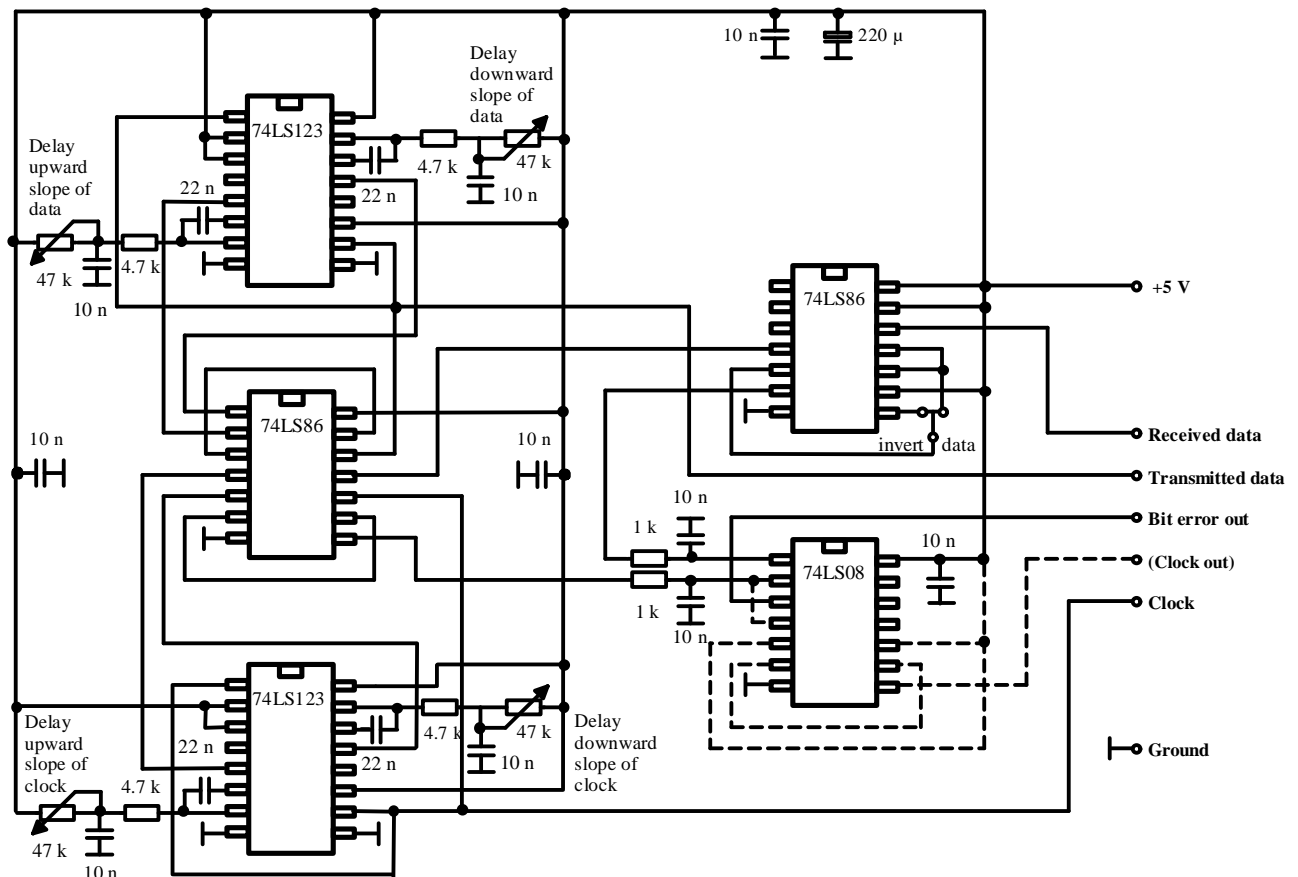

Figure 15 Circuit diagram of the BER measuring instrument

ANT012

The dimensioning of the measurement unit was done for data rates up to a few kBaud, all signals are based on TTL level. The adjustable time delay was realized with two double monoflops of the type 74LS123 in conjunction with the quad EXOR linkage 74LS86. With the component values given in the circuit diagram, the maximum delay time is approximately 800 μ s. The delay times for the upward- and the downward slope of the data must be equal, so that the bit length will not be changed. The sampling instant as well as the duration of the decision time are set by individual adjustment of the delay times for the upward- and the downward slope of the clock.

The two RC low-pass filters at the inputs of the AND gate 74LS08 eliminate pulse spikes that may be generated by the EXOR linkages, if their two input signals are not switched exactly at the same time. The time constants of the RC elements were set to 10 μ s, so that the influence on the data is nearly neglectable up to data rates about 10kBaud.

Figure 16 shows a measurement of bit error rates for AM- and for FM transmission with various deviations. For this example, a pseudo random sequence of 2^5-1 and a transmission rate of 2 kBaud is used. The measurement was taken on U4311B-C with ac-coupled data filters. The time of decision, whether a right or wrong bit was decoded, is set to the middle of the bits. Its length is 50 μ s, so it is short compared to the length of a bit. The measured IF level corresponds to the carrier peak level at the output of the used signal generator, according to the "high-level" of a square wave signal. The previous diagram shows, that the system's sensitivity and thereby the operation distance may be enlarged for constant transmitter output power and receiver sensitivity by higher FM deviation. System optimizing can be done on the transmitter part, too.

The following two measurements give a com-

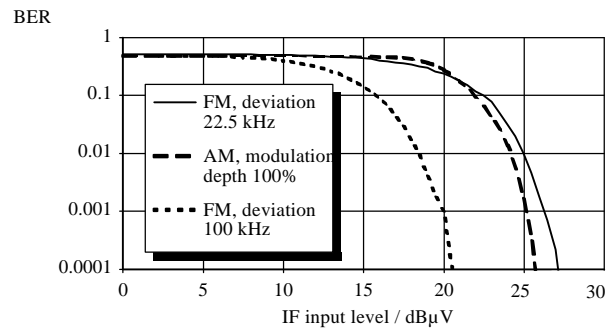

Figure 16 Bit error rates for a 2kbit/s PRS of length 2^5-1 , ac-coupled data filters

parison of the IF sensitivity of U4311B for a data transmission with a bit error rate (BER) below 10^{-3} in the AM- and FM mode. Within the next chapters we will examine the AM- and the FM system more closely. Figure 17 shows the dependence with the use of ac-coupled data filters, figure 18 is the measurement result for the quasi dc-coupled filters. The AM system using a modulation depth of 100% achieves the claimed BER at lower in-put levels than the FM system using 22.5 kHz deviation. It can be seen, that for modulation depths above 60%, sensitivity is nearly con-stant. So without any decrease of performance, modulation depths below 100% can be used, which is a method to reduce transient times at AM operation.

The FM system is superior to the AM system if the used deviation is more than 35 kHz. At a deviation of 100 kHz, the margin is about 5 dB. In this comparison, for AM a 2 kHz low-pass filter with a voltage gain of $A = -25$ was used as the ac-coupled filter, the dc-coupled filter was dimensioned according to figure 33. For FM, the gain was set to a value of $A = -3$ for the ac-coupled data filter and $A = -10$ for the dc-coupled filter, the latter was dimensioned according to figure 37. It can be seen, that the margin between wake up threshold and limiting sensitivity is approximately 20 dB for the actual dimensioning.

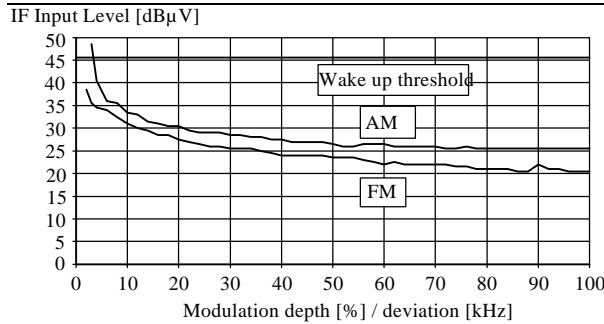

Figure 17 IF sensitivity for BER < 10³, ac-coupled data filter

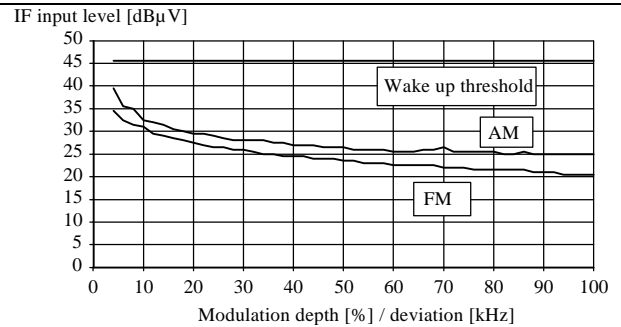

Figure 18 IF sensitivity for BER < 10³, quasi dc-coupled data filter

6. AM operation

As it has been mentioned before, an AM system is to realize with less expense, compared to an FM link. For our system, this applies mainly for the transmitter, while on the receiver side the additional expense is small. The AM amplifier provides a wide dynamic range and as it is not gain controlled, no settling times have to be considered when choosing the code for data transmission. However, the rise time of a simple one-stage-transmitter limits the maximum data transmission rate. The AM demodulator is a logarithmic type, so that the rectified voltage is compressed to avoid overshooting of the following operational amplifier. It can be used also in FM systems as a **Received Signal Strength Indicator (RSSI)**.

6.1 AM demodulator characteristic

The logarithmic AM demodulator output is a current source that can provide an output current up to approx. 100 μA. The measurement setup is the same as it was used for the examination of dc parameters according to figure 4. For all measurements concerning the demodulator characteristic, the data filter should not be connected to the demodulator output to avoid unwanted feedback.

The characteristic of the AM demodulator versus input level at different temperatures is

shown in figure 19. At low input levels as good as no temperature dependence is evident. Thereby, the wake up threshold, which determines the input sensitivity in the wake up mode - and finally the operation range of the transmission system - is nearly independent of temperature. This threshold is at pin 9 of the IC typically 40 dBμV, due to the loss in the resistors R9, R10 this corresponds to approx. 45.5 dBμV at the 50 Ω IF input of the test board. The spread of output signal at high input levels is compensated by the sliding comparator and therefore without any influence to the transmission quality.

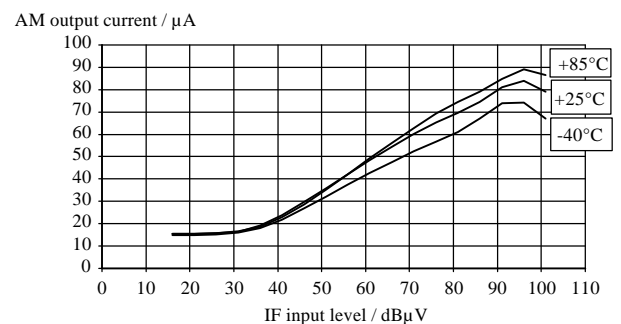

Figure 19 AM demodulator characteristic versus input level at different temperatures

As can be seen, the operation range of the AM demodulator covers more than six decades. This corresponds to the capability of simple tuners, higher dynamic ranges require a gain-controlled tuner. However, with regard to the

ANT012

given transmitter output power, such additional expense doesn't seem to be necessary.

For IF input levels above 95 dB μ V, the output current decreases. Utilizing AM modulation with small modulation depth, such high input levels should not be applied to avoid inverting of the demodulated data signal. With a modulation depth of more than 60%, this problem doesn't appear. Compression effects do not disturb the digital system, because at such high signal levels the signal-to-noise ratio is very high, as will be shown later.

The dependence of the supply voltage is very low, as shown in figure 20. It can be seen that for a supply voltage range from 3 V to 12 V, the variation of the wake up threshold is less than 0.5 dB. As the output stage is supplied by the internal reference voltage of 2.4 V, the obtainable output voltage is limited to this value. For this reason, the maximum reasonable value for the load resistance R 11 is 22 k Ω . It has to be considered, that this resistor determines the AM output impedance which must be obeyed at the dimensioning of the following data filter. Utilizing the quasi dc-coupled filter, additionally R 16 has to be taken into account.

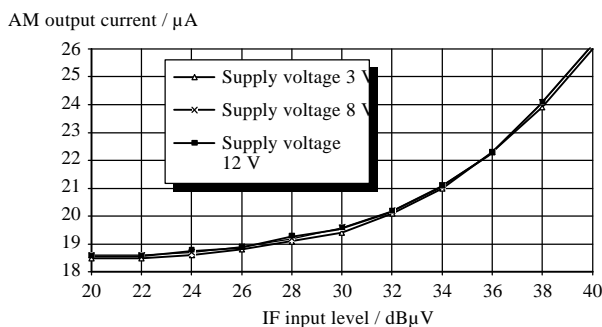

Figure 20 AM-demodulator characteristic versus input level for different supply voltages

6.2 Signal-to-noise ratio

The signal-to-noise ratio is a standard of the signal quality. To define a Signal + Noise / Noise (S+N/N) ratio in a digital AM system

with 100% modulation depth, it is to distinguish between two different kinds of noise:

- Low level: Measured with no input signal, therefore noise is constant.
- High level: Measured with an unmodulated carrier. While raising the level of the carrier from 0 dB μ V to approx. 35 dB μ V, noise increases because of the level dependent directivity of the logarithmic AM detector. With higher values of the input level, the amplification of the IF amplifier – and therefore also the noise – decreases.

The (S+N)/N ratio is the difference between the (S+N)- and the N curves. This ratio increases from 0 at the limiting sensitivity of 10 dB μ V to more than 60 dB referred to N_{high}, respectively 40 dB referred to N_{low}, at an input level of 80 dB μ V. In fact, the effective (S+N)/N ratio lies between those two values and depends on the probability of the low- and the high bits. The maximum signal-to-noise ratio is limited by the noise respectively the dynamic range of the receiver. At all (S+N)/N measurements, only thermal noise which can be considered as white Gaussian noise is present. Therefore, the sensitiveness of AM systems to pulse noise as for example ignition noise becomes not evident. As a rule of thumb, an (S+N)/N ratio of 10 dB is sufficient for a secure data transmission, but of course this value depends on the amount of transmitted data. The results of the BER measurements figures 17, 18 agree with this rule.

The (S+N)-curve is measured with a modulated carrier, modulated either with a sine wave or a rectangular signal. Figure 21 shows the signal-to-noise ratio at the AM output for a modulation depth of 100%. The ac voltage level (RMS) of the signal at R 11 = 10 k Ω is measured while the data filter is decoupled. The configuration for the measurement corresponds to figure 10, with exception of the AF meter, which is connected to the AM output.

The bandwidth of the AF meter is limited by a 22 kHz low-pass filter.

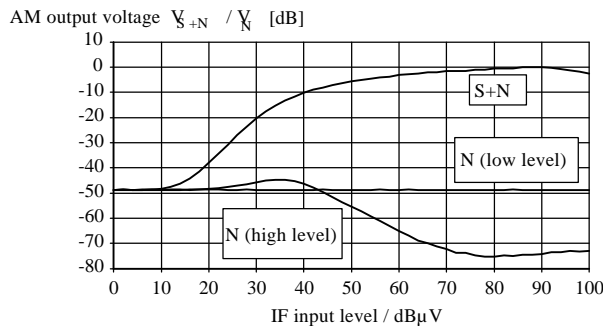

Figure 21 Signal-to-noise ratio for AM without data filter

The signal-to-noise ratio is improved by insertion of the data filter (here: ac-coupled type, voltage gain $A = -5$), as shown in figure 22. Here, the ac voltage level at the output (pin 2) of the ac-coupled data filter ($C_2 = 100 \text{ nF}$) is measured. With the exception of C_2 , the data filter is dimensioned according to figure 31, the measurement setup can be seen in figure 10. The measurement result with the quasi dc-coupled filter according to the circuit diagram figure 33 can be seen in figure 23. The filter has a voltage gain of $A = -25$ to exceed the comparator's limiting sensitivity even for low

7. FM operation

The U4311B/ U4313B offer the possibility to realize FM operation with low expenditure. Only a discriminator filter and two resistors, R 14 and R 15, have to be added, compared to AM operation. The performance of a FM link is correlated to the system bandwidth, as the BER measurement versus frequency deviation figures 17, 18 made it obvious. The optimum system bandwidth depends on the FM deviation, the manufacturing tolerance of the frequency determining elements in the transmitter and the receiver's local oscillator. Their fre-

quency drift with temperature has to be considered as well. The most current solution to achieve stable transmission frequency is a SAW resonator. Usually, such resonators are available with a manufacturing tolerance of 150 kHz, with additional temperature drift in the range of $\pm 50 \text{ kHz}$. If the same tolerances appear both in the transmitter and in the receiver, the total amount of all tolerances is 500kHz. The bandwidth of the receiver's IF processing has to be matched to the one of the system.

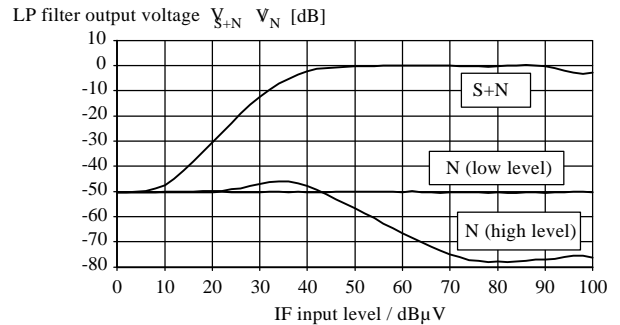

Figure 22 Signal-to-noise ratio for AM with 2kHz Bessel low-pass filter, ac coupled, $A = -5$

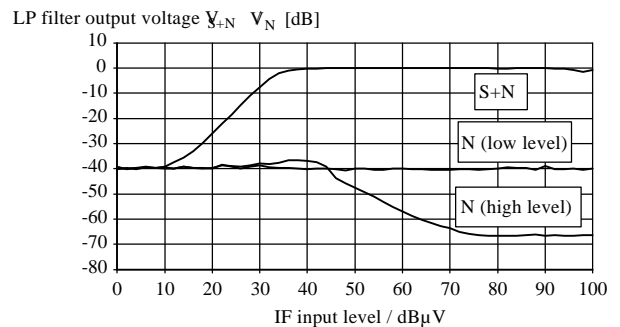

Figure 23 Signal-to-noise ratio for AM with 4kHz low-pass filter, quasi dc coupled, $A = -25$

quency drift with temperature has to be considered as well.

The most current solution to achieve stable transmission frequency is a SAW resonator. Usually, such resonators are available with a manufacturing tolerance of 150 kHz, with additional temperature drift in the range of $\pm 50 \text{ kHz}$. If the same tolerances appear both in the transmitter and in the receiver, the total amount of all tolerances is 500kHz.

The bandwidth of the receiver's IF processing has to be matched to the one of the system.

ANT012

The former consists mainly of the bandwidths of the IF- and the discriminator filter. Because of the SAW tolerances, the discriminator filter advantageously should be tunable, so that the manufacturing tolerance of the receiver's SAW resonator can be equalized. If it is taken into account that receiver and transmitter normally will work at temperatures not too different from each other, the proposed discriminator bandwidth of 300 kHz, according to figure 24 with $C_{10} = 22 \text{ pF}$, is sufficient for actual conditions, i.e. for frequency deviation between 10 kHz and 20 kHz. Using SAW-based transmitters, higher frequency deviations are difficult to be achieved.

SAW resonators with 75 kHz tolerance are on the market, devices with 50 kHz are under development. TEMIC recommends these components to achieve best possible system performance.

If other concepts are used for stabilization of the operation frequency, for instance X-tal controlled systems, the adjustment of the discriminator's center frequency might not be necessary. In this case, also single-ended ceramical discriminator filters can be used, connected directly from pin 12 to ground. As another benefit, the given system bandwidth of approximately 300 kHz may be better exploited by higher frequency deviation up to 100 kHz or more.

7.1 Discriminator characteristic and bandwidth

The preceding explanations showed, that the necessary bandwidth of the IF part is rather determined by the tolerance of the SAWs than by the deviation of the transmitter. With increasing bandwidth of the discriminator, the amplitude of the output signal decreases and therefore the signal-to-noise ratio is getting worse, which reduces the obtainable operation distance.

The FM demodulator stage is suited for a dis-

criminator filter of single-ended type as well known from integrated one-chip radio circuits. The discriminator works on $j 800 \Omega$ load and therefore may be matched directly to a ceramical resonator. The discriminator filter can also be composed of discrete components formed as a L/C-tank circuit, so that an adjustment of the center frequency is possible. The discriminator filter should be temperature-compensated to ensure a constant center frequency over the operating temperature range.

The discriminator filter is of notch type. The demodulator bandwidth depends on the one hand from the difference between the serial and the parallel resonance of the discriminator filter, adjustable by the series capacitor C_{10} .

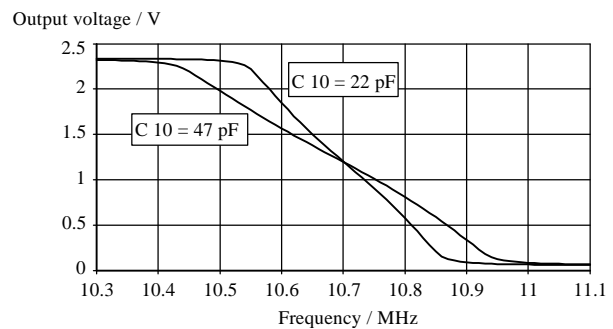

Figure 24 Characteristic of the FM discriminator

On the other hand, the steepness of the S-curve can be adjusted by two external resistors R 14, R 15. With higher values of the resistors the bandwidth decreases. It has been mentioned formerly, that these resistors are a component of the FM output resistance which must be well-defined for correct operation of the following data filter. The influence of a variation of the resonances, here achieved by variation of C_{10} , is drawn in figure 24. To meet best transmission characteristic in a FM system, the cut-off frequency of the FM discriminator should correspond to the -3 dB bandwidth of the receiver's overall IF frequency response. The measurement setup can be seen in figure 25, the data filter must be decoupled from the FM demodulator output. The dc voltage at the FM output is measured, the IF level applied to the test board is 70dB μ V.

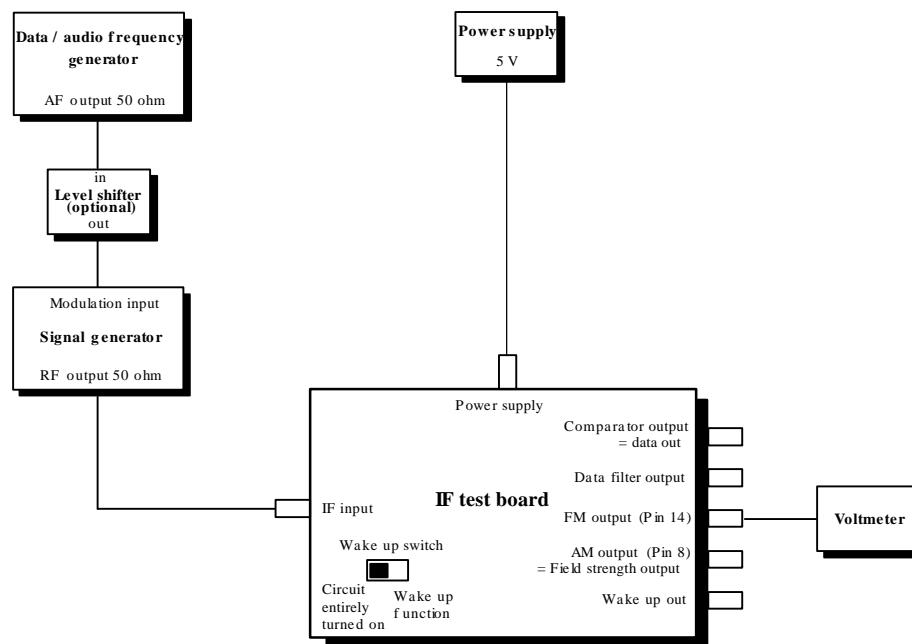

Figure 25 Setup for measurement of the FM characteristic

7.2 Signal-to-noise ratio

The next figures present the signal-to-noise ratios versus input level for the IF test board with FM operation and various types of data filters and frequency deviations. The measuring was carried out in analogy to that at the AM receiver, the measurement setup corresponds to figure 10.

Figure 26 shows the signal to noise ratio for a

FM output voltage V_{S+N} / V_N [dB]

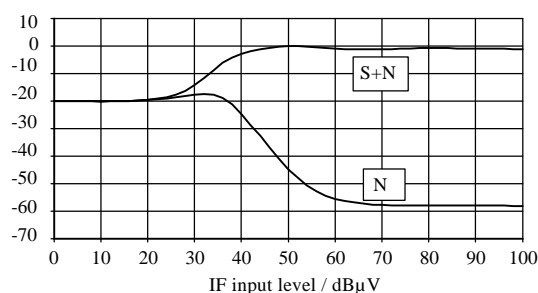

Figure 26 Signal to noise ratio for FM without data filter, deviation 22.5kHz

frequency deviation of 22.5 kHz without any data filter, the limiting sensitivity is 10 dB μ V and therefore worse, compared to that of the AM system. However, the (S+N)/N ratio increases more rapidly with the input level due to the threshold effect of the FM system. Here, one benefit of the FM system becomes obvious: The level of the RF signal and therefore also the noise is independent of the transmitted information. Therefore, the (S+N)/N ratio at higher input levels is better than that of the AM receiver.

The signal-to-noise ratio at low IF input levels is improved by the data filter, as it is obvious in figure 27. For this measurement, the ac-coupled data filter according to figure 35 is used. The corresponding graph for the quasi dc-coupled data filter dimensioned according to figure 37 is shown in figure 28. At last, the signal-to-noise ratio for a frequency deviation of 100 kHz is given in figure 29, using the same quasi dc-coupled data filter as for the measurement before.

ANT012

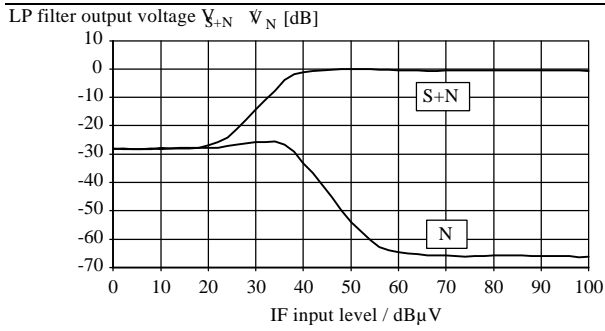

Figure 27 Signal-to-noise ratio for FM with 2kHz Bessel low-pass filter, ac coupled, deviation 22.5kHz

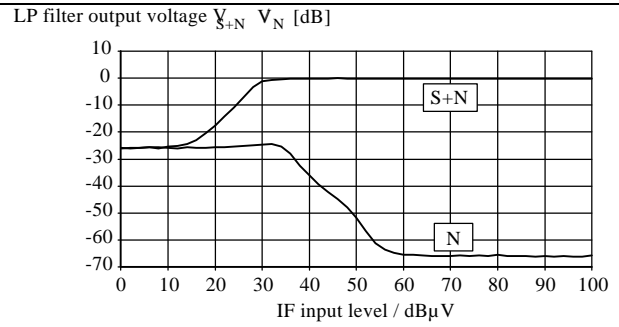

Figure 29 Signal-to-noise ratio for FM with 2kHz low pass filter, quasi dc coupled, deviation 100kHz

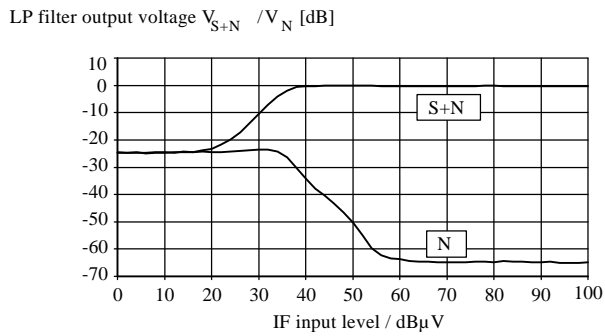

Figure 28 Signal-to-noise ratio for FM with 2kHz low pass filter, quasi dc coupled, deviation 22.5kHz

8. Circuit diagrams

The printed circuit board is identical for all types of receiver ICs and is suited for AM- as well as for FM operation. Both types of data filters, no matter if ac- or quasi dc-coupled, can be realized. The adaptation to the desired modulation type is carried out by component assembling. The wake up and the comparator output of the ICs are equipped with an open collector. For the test circuits, these outputs are referred to the stabilized voltage $V_{ref} = 2.4\text{ V}$ by means of the resistors R 8 respectively R 13.

The PCB also offers the option to refer the outputs to the supply voltage V_s . Especially with regard to the connection to a micro-

controller with a supply voltage of 5 V, this possibility is favorable. If the data input of the microcontroller provides an internal pull up resistor, R 13 may be left out.

For purpose of coupling the IF input to the IC, also a ceramical filter for 10.7 MHz can be used instead of C 11. The layout offers both possibilities. The PCB is suited to use a SMB connector for the IF input.

The LC discriminator tank may be replaced by a single-ended ceramical discriminator, in this case C 10 has to be replaced by a bridge. We recommend the ceramical discriminator MURATA CDA 10.7 MC1, which offers a bandwidth of 200kHz.

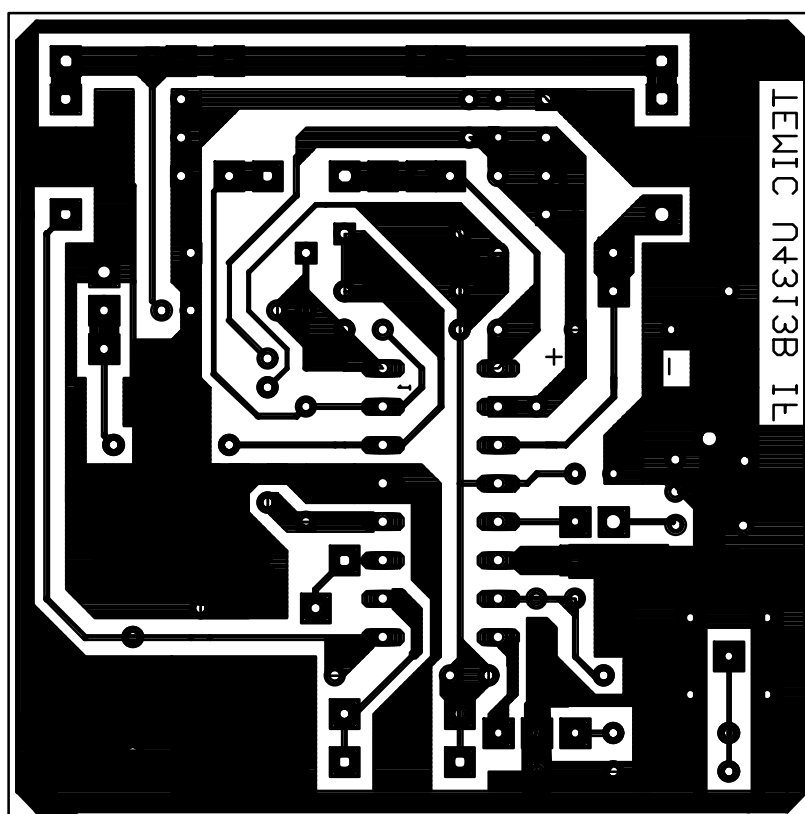

Figure 30 Universal PCB layout for the AMFM test circuits, scale 2:1, view: component side

ANT012

8.1 IF test board for AM operation

AM test circuit with 2kHz Bessel low-pass data filter with ac-coupling, $\Delta -5$,
(same circuit for U4311BC)

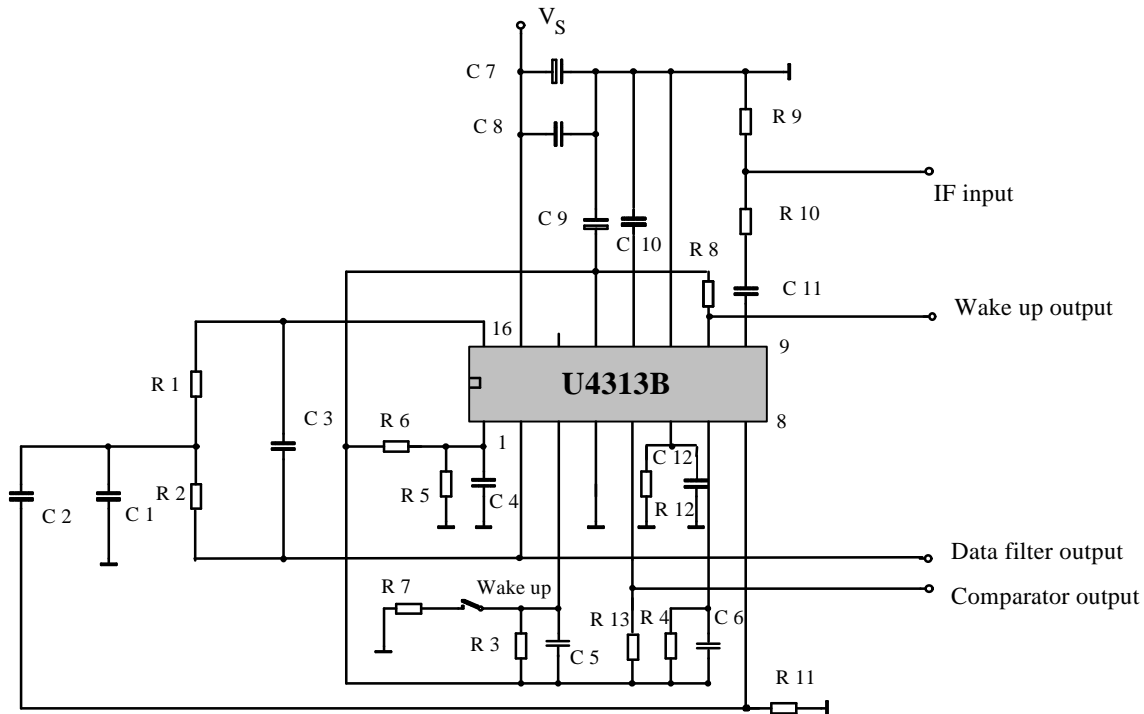

Figure 31 Circuit diagram

Part list

R 1	15 k Ω	C 1	5.6 nF
R 2	51 k Ω	C 2	1 μ F
R 3	220 k Ω	C 3	820 pF
R 4	100 k Ω	C 4	100 nF
R 5	100 k Ω	C 5	220 nF
R 6	100 k Ω	C 6	1 μ F
R 7	22 k Ω	C 7	10 μ F
R 8	100 k Ω	C 8	100 nF
R 9	56 Ω	C 9	10 μ F
R 10	300 Ω	C 10	10 nF
R 11	10 k Ω	C 11	10 nF
R 12	100 k Ω	C 12	1 μ F
R 13	10 k Ω		

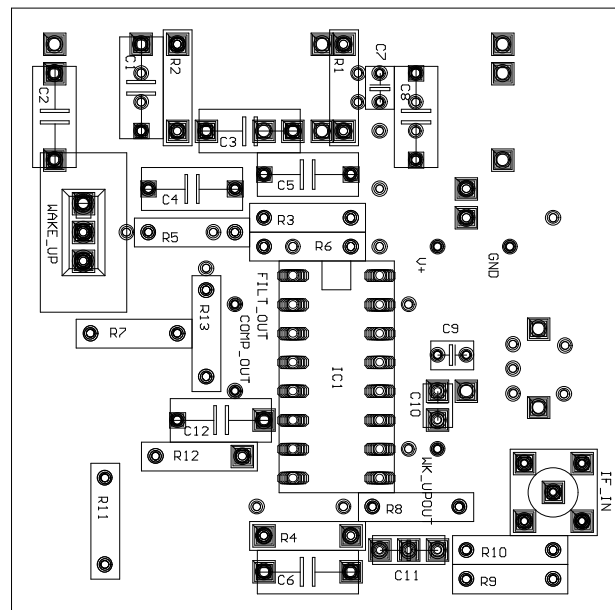

Figure 32 Components placement

AM test circuit with 4kHz low-pass data filter with quasidc-coupling, $A = -25$
(same circuit for U4311B-C)

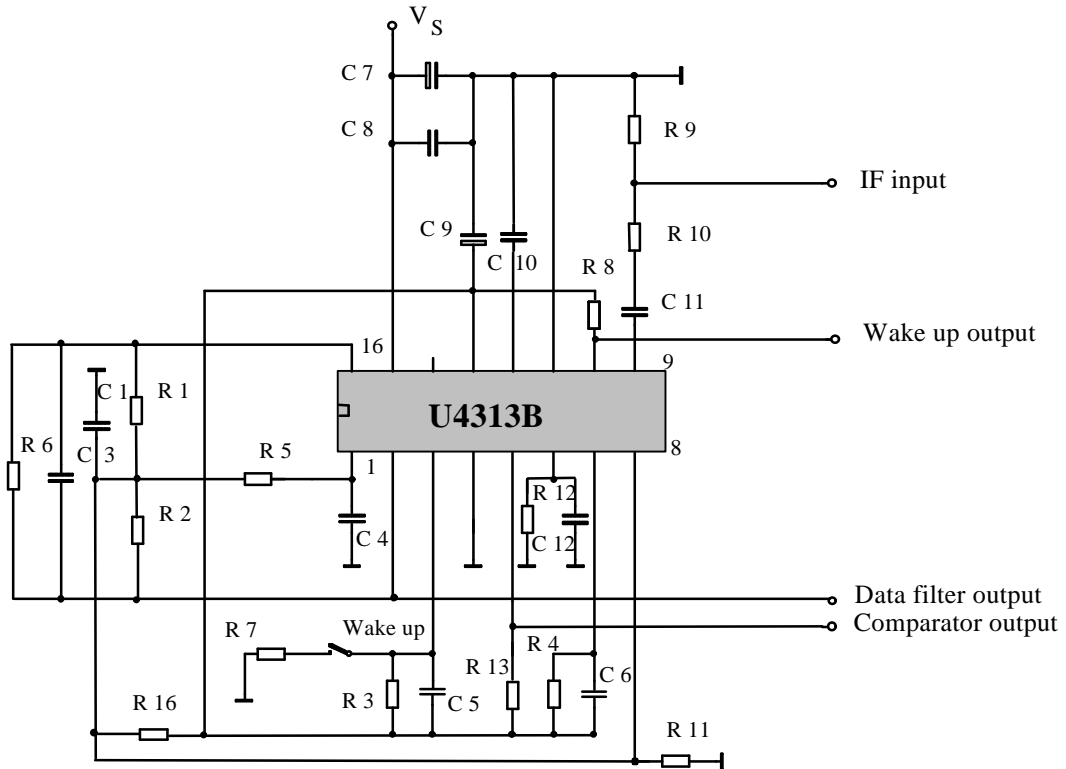

Figure 33 Circuit diagram

Part list

R 1	22 k Ω	C 1	4.7 nF
R 2	680 k Ω	C 3	82 pF
R 3	220 k Ω	C 4	220 nF
R 4	330 k Ω	C 5	220 nF
R 5	100 k Ω	C 6	220 nF
R 6	1 M Ω	C 7	10 μ F
R 7	22 k Ω	C 8	100 nF
R 8	100 k Ω	C 9	10 μ F
R 9	56 Ω	C 10	10 nF
R 10	300 Ω	C 11	10 nF
R 11	18 k Ω	C 12	220 nF
R 12	330 k Ω		
R 13	10 k Ω		
R 16	100 k Ω		

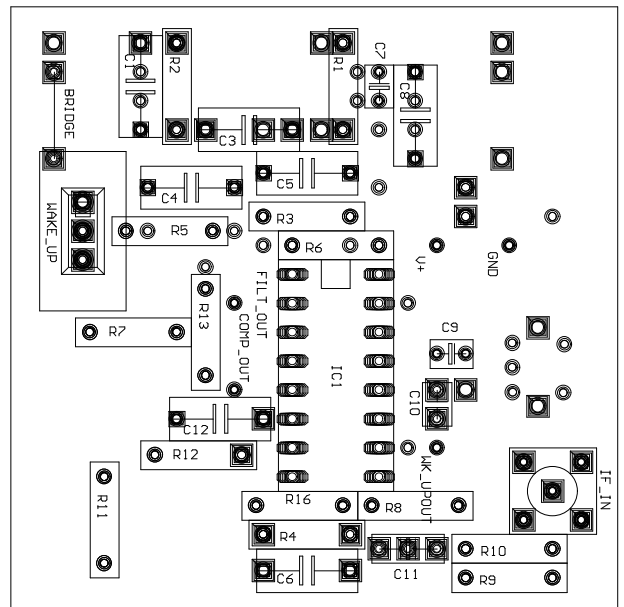

Figure 34 Components placement

ANT012

8.2 IF test board for FM operation

FM test circuit with 2kHz Bessd low-pass data filter with ac-coupling, $A_v -5$
(same circuit for U4311BC)

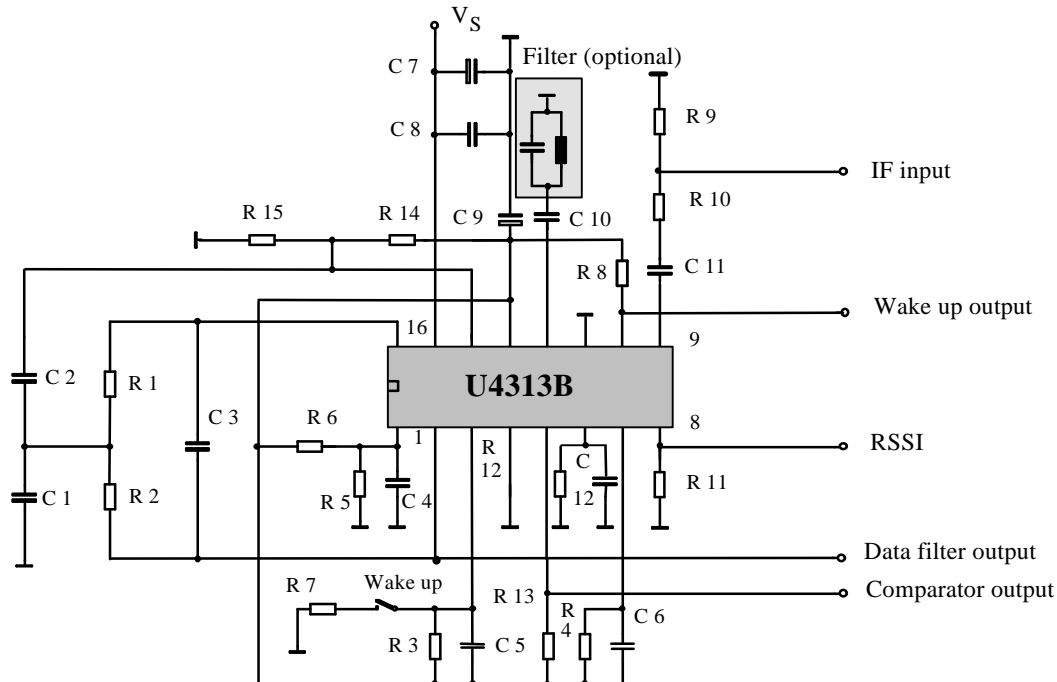

Figure 35 Circuit diagram

Part list

R 1	15 k Ω	C 1	5.6 nF
R 2	51 k Ω	C 2	1 μ F
R 3	220 k Ω	C 3	820 pF
R 4	100 k Ω	C 4	100 nF
R 5	100 k Ω	C 5	220 nF
R 6	100 k Ω	C 6	1 μ F
R 7	22 k Ω	C 7	10 μ F
R 8	100 k Ω	C 8	100 nF
R 9	56 Ω	C 9	10 μ F
R 10	300 Ω	C 10	22 pF
R 11	10 k Ω	C 11	10 nF
R 12	100 k Ω	C 12	1 μ F
R 13	10 k Ω	Filter	TOKO
R 14	22 k Ω		A119ACS-19000Z
R 15	22 k Ω		(L = 2.2 μ H,
			C = 100 pF)

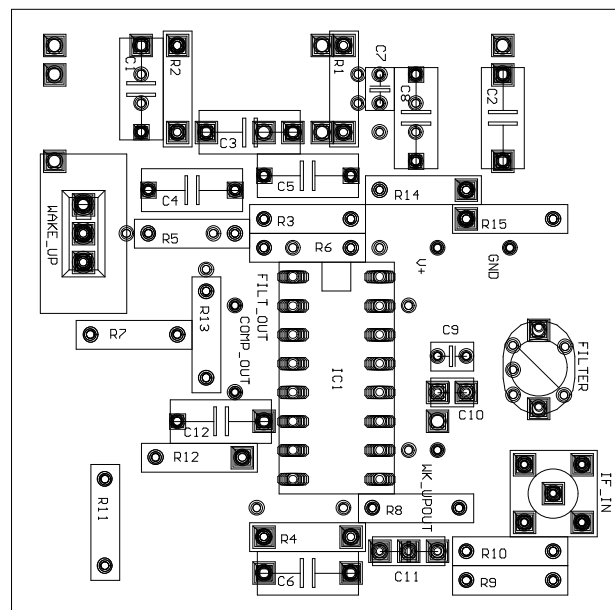

Figure 36 Components placement

FM test circuit with 2kHz low-pass data filter with quasi dc-coupling, A -10
(same circuit for U4311B-C)

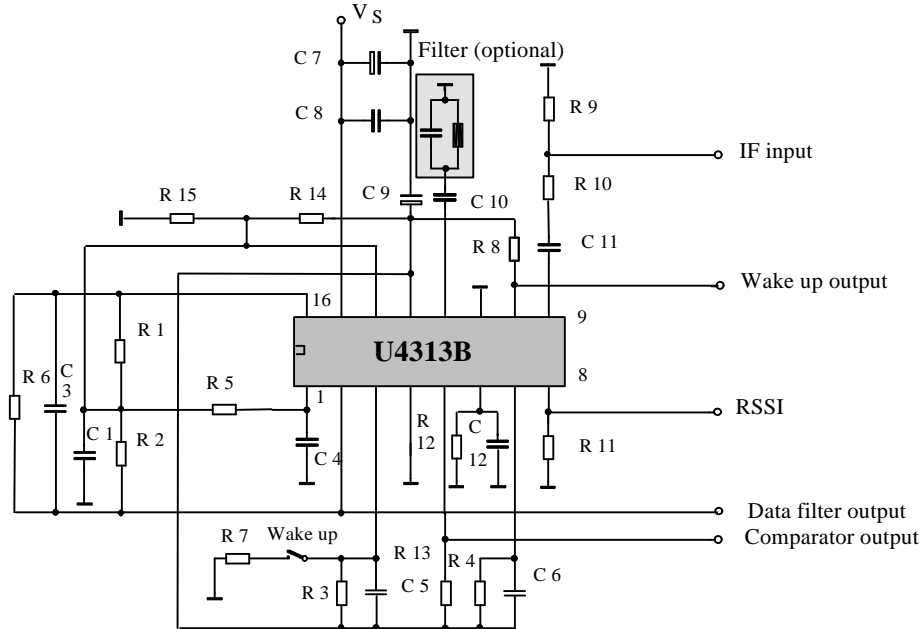

Figure 37 Circuit diagram

Part list

R 1	22 k Ω	C 1	15 nF
R 2	100 k Ω	C 3	330 pF
R 3	220 k Ω	C 4	47 nF
R 4	330 k Ω	C 5	220 nF
R 5	100 k Ω	C 6	220 nF
R 6	1 M Ω	C 7	10 μ F
R 7	22 k Ω	C 8	100 nF
R 8	100 k Ω	C 9	10 μ F
R 9	56 Ω	C 10	22 pF
R 10	300 Ω	C 11	10 nF
R 11	18 k Ω	C 12	220 nF
R 12	330 k Ω	Filter	TOKO
R 13	10 k Ω		A119ACS-19000Z
R 14	22 k Ω		(L = 2.2 μ H,
R 15	22 k Ω		C = 100 pF)

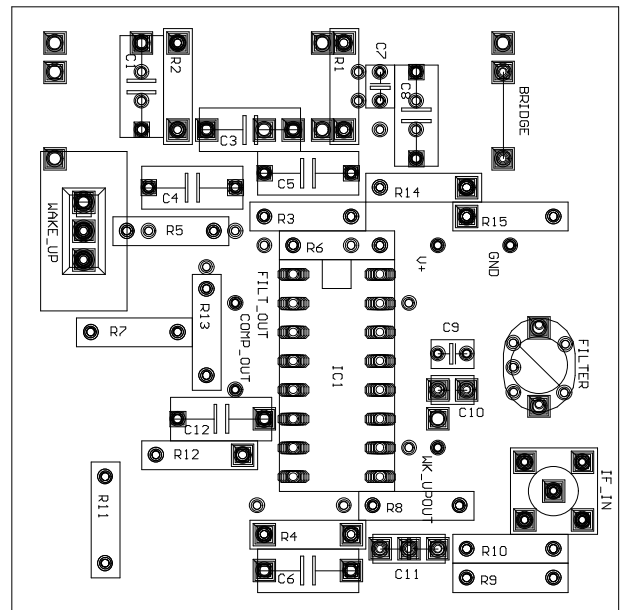

Figure 38 Components placement

ANT012

9. Complete UHF remote control system

The following circuits within this section are proposals how a complete RF link may be realized. The design of PCBs in the UHF range presumes care and experience, as the PCB appears as a component, too. One of the most critical parameters is size and quality of the discrete components. For the producer of such subassemblies, the possibilities of a potential mass production have to be considered.

9.1 Circuit proposal for an UHF transmitter for AM- or FM operation

Within this chapter we'll give a circuit proposal, which may just give an idea how to realize a transmitter, of course there are other possibilities. In practice, the transmitter module contains not only the RF transmitter but also either a data and control interface or even a μC or μP for encoding. However, we will only discuss the transmitter's RF part.

In a simple design it consists only of one single stage, a SAW-based oscillator whose inductance of the tank circuit is realized as a loop and acts also as antenna. When designing the RF transmitter, the quality factor, Q , of the loop antenna is important. A doubling of Q

yields a four times larger total transmitted power.

Another benefit of high Q is less obvious but at least as important. The higher the quality factor, the greater the ratio of the effective current of the fundamental wave, compared to the current of the harmonics, because the resonance step-up appears only at the resonance frequency of the antenna circuit. Therefore, the suppression of radiated harmonics is essentially determined by the quality factor of the aerial. We will have a closer look on the theoretical background within chapter 10.

An example of a simple single-stage transmitter for operation on 433.92 MHz is given in figure 39. It can be amplitude-modulated by switching the base voltage of the transistor (Amplitude Shift Keying, ASK) as well as frequency-modulated by the help of a varicap in the tank circuit. The varicaps are used to realize an almost powerless frequency modulation. If FM operation is not desired, R 5, R 6, C 9 and D 1 can be left out. In this case, C 6 and C 8 are replaced by one capacitor of 3.3 pF, C 5 is set to 22 pF. The transmitter works with a supply voltage between 3.6 V and 6 V (two lithium cells). Applying 5 V supply voltage, data signals with TTL level can be used for modulation.

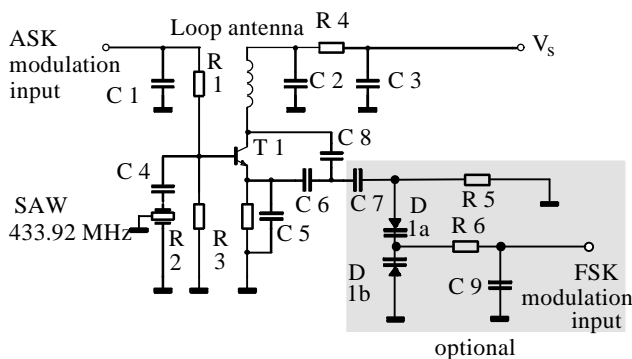

Figure 39 AM/ FM transmitter circuit diagram

Components

SAW 433.92MHz, Siemens Matsushita R2527

T 1	S 852 T	R 3	220 Ω
D 1	BB 804	R 4	510 Ω
R 1	15 k Ω	R 5	10 k Ω
R 2	4.7 k Ω	R 6	10 k Ω
C 1	100 pF	C 6	8.2 pF
C 2	100 pF	C 7	10 pF
C 3	10 nF	C 8	3.3 pF
C 4	39 pF	C 9	100 pF
C 5	8.2 pF		

9.2 Circuit proposal for an UHF superheterodyne receiver

Our proposal for a low-current receiver includes the previously commented standby concept in conjunction with a special circuit arrangement consisting of the stacking of circuit stages for current reducing. This dc stacking appears on the one hand inside the tuner and on the other hand in the cascading of the entire tuner with the remaining IF- and baseband parts, which are covered by the receiver IC. The principle configuration of the receiver can be seen in figure 40.

Regarding the signal path, the input stages are cascaded to achieve higher sensitivity and better rejection of the local oscillator radiation compared to a single-stage preamplifier. The mixer may be of self-oscillating type or master-excited, depending on requirements of large-signal behavior. For both types, the local oscillator is stabilized by a SAW resonator.

Different current consumption between front end and the IF circuitry is buffered by the Zener diode. As the power consumption of the RF section is lower than that of the IF part - dependent of the receiver IC mode - the Zener diode takes over the differential current between active and standby mode. It clamps the front end supply voltage to approximately 5.6 V. To achieve sufficient stabilization, a low-current Zener diode is helpful. The total supply current of the unit is limited by the IF circuit - no series resistor is necessary.

Figure 41 shows a circuit proposal for a low-current FM receiver working on 433.92 MHz, according to the concept as described before. The receiver is designed for 9 V to 18 V supply voltage and a total quiescent current consumption of approximately 1 mA.

Coming from the antenna input with a characteristic impedance of 50 Ω , the received signal passes a double-tuned miniature helical filter.

This pre-selector provides good far-off selectivity, improves image rejection and makes the subsequent prestage insensitive to deviations of the antenna impedance. The two preamplifiers in common base circuit are dc-cascaded. The grounded base amplifiers are distinguished by a high reverse isolation and guarantee a good suppression of the local oscillator signal to the antenna input. Maximum gain of the input stages can be achieved by tuning of L 101, L 102, C 109.

The LO level as well as spurious response and harmonics are less than -65 dBm at any port of the receiver module, if it is encased in a tin plate cabinet for shielding. In the tuner, special low-noise, low-current, low-voltage bipolar transistors are applied. The transition frequency of the used S 852 T is 3 GHz for a given collector current of 0.5 mA, which provides a gain of about 10 dB per stage at 433.92 MHz. Alternatively the S822T may be used, providing a slightly improved transition frequency compared to S852T. Using a common base circuit, the input impedance of these transistors is approximately 50 Ω for a collector current of 0.5 mA.

In the following self-oscillating mixer, the signal is converted to the intermediate frequency of 10.7 MHz. The large-signal characteristic of the receiver can be improved by using a master-excited mixer as proposed in figure 42, whereby the complexity of the circuitry and its power consumption are slightly increased. By means of a SAW resonator as frequency determining element, the local oscillator is oscillating at a high frequency in the UHF band and therefore no frequency multiplication is necessary. This results in a tuner free of spurious resonances at a minimal expense. The oscillator frequency can be adjusted exactly by tuning of L104.

The Zener diode D 101 keeps the operating points of the transistor stages in the tuner constant although the total current consumption depends on the mode of the receiver. For protection against wrong polarity of the power

ANT012

supply, the suppressor diode D 102 can be used. Compared to a diode in series with the receiver, it causes no voltage drop and can be used also for transient suppression.

The tuner works without Automatic Gain Control (AGC) to avoid settling time problems especially in AM systems. Therefore, the dynamic range of the subsequent stages must be kept in view. The IF part is dimensioned according to figure 35 for FM operation with an ac-coupled data filter.

Special care has to be taken when designing the layout of the printed circuit board. This is necessary to avoid parasitic oscillations and coupling by ground lines. The preceding and the subsequent RF circuits correspond to first samples built for examinations in the lab. More detailed informations about complete RF links will be given in a separate paper.

Another receiver circuit proposal with the IF part designed for AM operation is given in figure 42. In the tuner, a master-excited mixer is used, realized as a kind of cascode circuit with the local oscillator. The mixer gain can be enlarged by insertion of C 116. L 107 and C 112 work as an absorption circuit for the IF, C 111 suppresses backward mixing at the collector base diode of T103.

For the given polling concept, the IF part is designed as a circuit with minimal expense. The data filter is a simple low-pass filter of first order with a voltage gain of $A = -25$, the high-frequency cut-off is 2 kHz. The diode D 102 may be inserted to avoid damage caused by wrong polarity of the supply voltage. Due to the voltage drop at this diode, the supply voltage range of the receiver is shifted to higher values (approx. plus 0.6V)

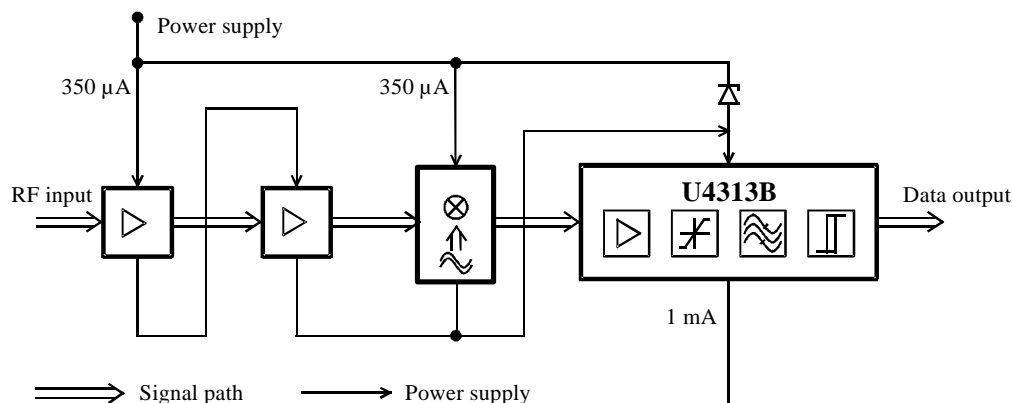

Figure 40 RF receiver unit schematic diagram

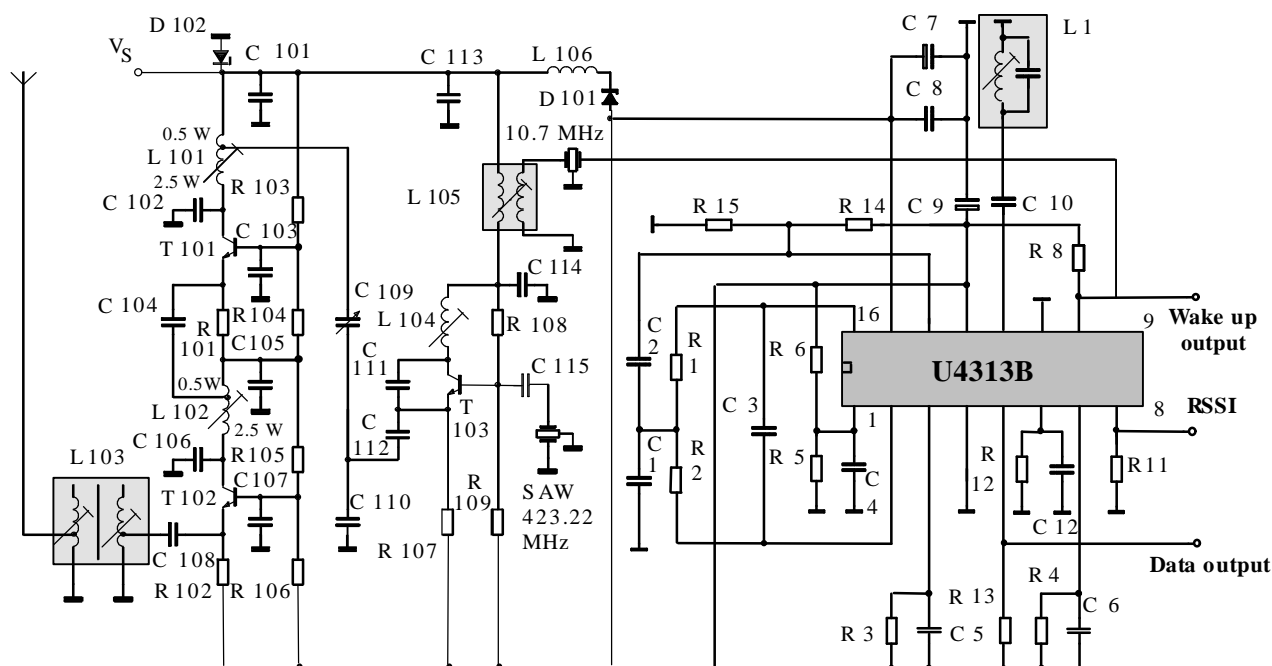
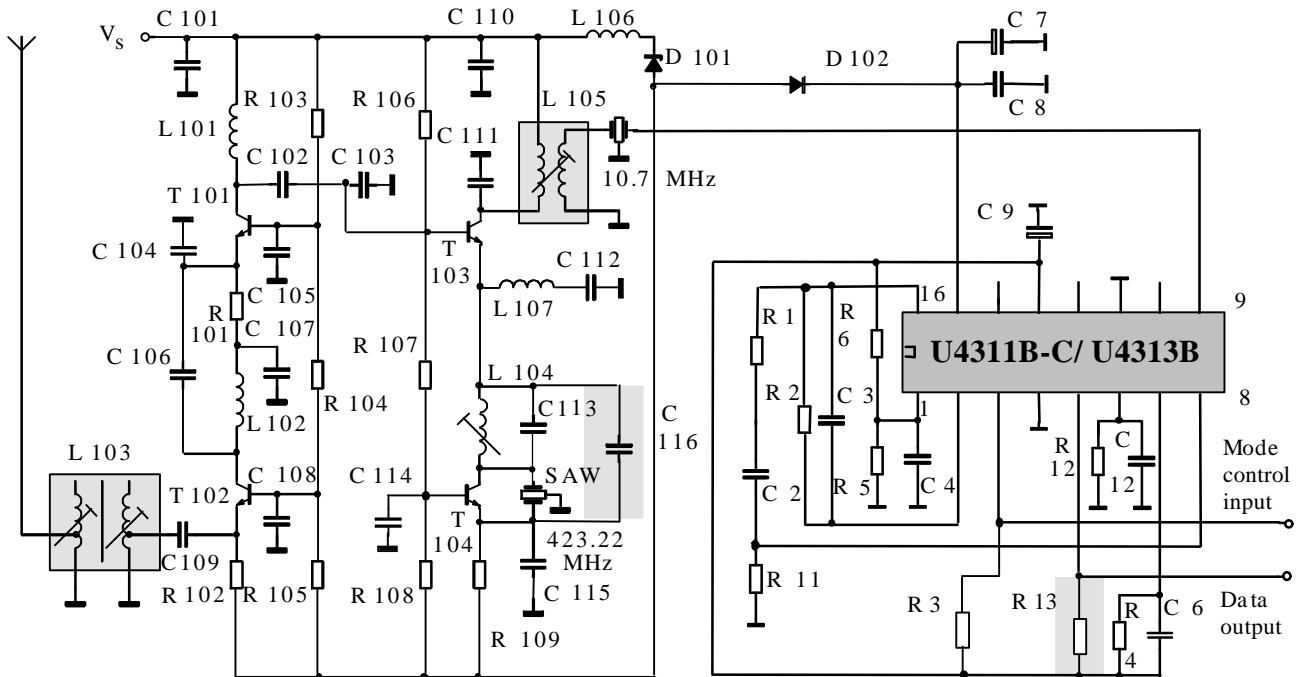

Figure 41 Circuit diagram of RF receiver unit for FM operation using a self oscillating mixer, wake-up method

Components

R 1	15 kΩ	C 1	5.6 nF	D102	BZT03/D18	C 105	100 pF
R 2	51 kΩ	C 2	1 μF		(TEMIC TFK)	C 106	3 pF
R 3	220 kΩ	C 3	820 pF	R 101	1.5 kΩ	C 107	100 pF
R 4	100 kΩ	C 4	100 nF	R 102	1.5 kΩ	C 108	10 pF
R 5	100 kΩ	C 5	220 nF	R 103	22 kΩ	C 109	6 pF
R 6	100 kΩ	C 6	1 μF	R 104	47 kΩ	C 111	4.7 pF
R 7	22 kΩ	C 7	10 μF	R 105	22 kΩ	C 112	12 pF
R 8	100 kΩ	C 8	100 nF	R 106	47 kΩ	C 113	10 nF
R 11	10 kΩ	C 9	10 μF	R 107	1.5 kΩ	C 114	100 pF
R 12	100 kΩ	C 10	22 pF	R 108	91 kΩ	C 115	33 pF
R 13	10 kΩ	C 12	1 μF	R 109	33 kΩ		
R 14	22 kΩ	L1	TOKO A119ACS-19000Z				
R 15	22 kΩ		(L = 2.2 μH, C = 100 pF)				
T 101	S852T	C 101	100 pF				
T 102	S852T	C 102	3 pF				
T 103	S852T	C 103	100 pF				
D 101	DTZ 5,6 B	C 104	10 pF				
	(Rohm)	C 110	39 pF				
				L 101, 102, 104	air coils, 3 winding turns, ∅ 5 mm, wire 0.8 mm		
				L 103	helical filter COMPONEX 5HW 40545 A 435		
				L 105	IF transformer 12:3, TOKO A119ACS-18999N (without internal capacitor)		
				L 106	470 nH		
				SAW resonator	423.22MHz R2531 (Siemens Matsushita Components)		

ANT012



C 116/ R 13 = optional

Figure 42 Circuit diagram of RF receiver unit for AM operation using a master-excited mixer, polling method

Components

R 1	10 k Ω	C 2	1 μ F	R 102	1.5 k Ω	C 110	100 pF
R 2	27 k Ω	C 3	2.7 nF	R 103	22 k Ω	C 111	100 pF
R 3	220 k Ω	C 4	100 nF	R 104	22 k Ω	C 112	470 pF
R 4	100 k Ω	C 6	1 μ F	R 105	47 k Ω	C 113	3.3 pF
R 5	100 k Ω	C 7	10 μ F	R 106	22 k Ω	C 114	100 pF
R 6	100 k Ω	C 8	100 nF	R 107	22 k Ω	C 115	3.3 pF
R 11	10 k Ω	C 9	10 μ F	R 108	56 k Ω	C 116	8.2 pF
R 12	100 k Ω	C 12	1 μ F	R 109	470 Ω		
R 13	10 k Ω						

T 101	S852T	C 101	100 pF
T 102	S852T	C 102	3.9 pF
T 103	S852T	C 103	18 pF
T 104	S852T	C 104	18 pF
D 101	DTZ 5,6 B (Rohm)	C 105	100 pF
		C 106	3.9 pF
		C 107	100 pF
D 102	1N4148	C 108	100 pF
R 101	1.5 k Ω	C 109	10 pF

L 101, 102, 104 air coils, 3 winding turns, \varnothing 5 mm,
wire 0.8 mm

L 103 helical filter COMPONEX 5HW 40545 A 435
L 105 IF transformer 12:3, TOKO A119ACS-18999N
(without internal capacitor)

L 106 470 nH

L 107 470 nH

SAW resonator 423.22MHz R 2531
(Siemens Matsushita)

9.3 Complete UHF link

A complete 433 MHz UHF remote control system based on the concept as described before is under development as a joint project between TEMIC semiconductor and subassembly divisions. Normally, the transmitter is custom-designed, in accordance to the requirements of size, coding system, output power specifications, etc. The receiver is designed as an universal module. The unit may be custom-specified for FM- or AM operation and to the desired data telegram by component placement and selection.

TEMIC subassembly division has experience in manufacturing about three million TV tuners per year. This provides best conditions for a high-performance system with large scale production.

9.4 Summary and future considerations

With the integrated circuits U431xB, M43C200 and the UHF transistors S822T, S852T, TEMIC TELEFUNKEN microelectronic provides predestined components for RF-based remote control systems, permitting specific- and therefore also cost-saving solutions for most applications. Owing to the superhet concept and the IF interface, a high flexibility with regard to operation frequencies and system performance is guaranteed.

The presented report described the function of

the integrated circuits U431xB and explained the fundamental system aspects. Some applications of the IF receiver ICs were discussed, giving comprehensive design hints for the application circuits including a PCB layout. The applied measurement techniques, which have been illustrated, make it possible to characterize and optimize the complete system.

The resulting circuit proposals presented in this report had been realized as first samples in the laboratory and worked well.

Finally we give a prospect of possible further developments.

Another application report is available, containing more information about a complete RF receiver [9]. This report is based on the explanations and the measurement techniques developed within the report in hand. We focus on the tuner, discussing circuit proposals and measurement results.

We will develop a PLL-based transmitter with better frequency tolerance and improved modulation capability. Due to the limited modulation capability of the actual SAW-based FM transmitter design, frequency deviation is limited to less than ± 20 kHz. Unfortunately, the tolerance of the SAWs demand an IF bandwidth of more than 300 kHz. For this reason, an increase of FM deviation to about 100 kHz will result in an improvement of the system-sensitivity of approximately 6 dB. Certainly semi-duplex and full-duplex radio links will be needed for special applications and we intend to include this also in our future activities.

10. Appendix (Study of radio wave radiation and propagation at the operating frequency and the harmonics)

In this chapter we will skeletonize the theoretical relations of the radiation and propagation of radio waves. This may serve to point out the most important parameters of a RF link and to get some physical criterions for the choice of an optimal operating frequency range. By the hand of a small tuned loop antenna we want to show, which parameters are to be optimized to achieve maximum effective radiated power at the operating frequency while keeping the emission of harmonics low.

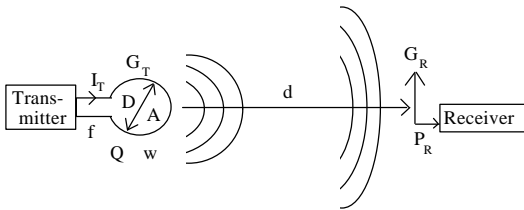

Figure 43 RF link

The benefits of the UHF range become obvious by a study of the radio wave propagation versus frequency. For simplification, we assume free-space propagation and consider only the far field region.

Referring to a transmission at a frequency f , respectively a wavelength λ , the received power P_R in a distance d from the transmitter, with output power P_T and an antenna gain G_T referred to an isotropic radiator, respectively G_R on the receiver side is according to reference [3]

$$P_R = P_T \cdot \frac{\lambda^2}{(4 \cdot \pi \cdot d)^2} \cdot G_T \cdot G_R \quad (1)$$

The logarithmic attenuation ratio L_0 for free-space propagation is defined as

$$\frac{L_0}{\text{dB}} = -10 \cdot \log \frac{P_R}{P_T} = 32.5 \text{dB} + 20 \cdot \log \frac{d}{\text{km}} + 20 \cdot \log \frac{f}{\text{MHz}} - 10 \cdot \log G_T - 10 \cdot \log G_R \quad (2)$$

Taking the widespread demand for small size into account, a small loop antenna seems to be a good choice. The pattern of such an antenna is equal to that of a Hertzian dipole with a gain of $G = 1.5$. Supposing the transmitter, as well as the receiver antennas, are to be of that kind ($G_T = G_R = 1.5$), we obtain from equation(2)

$$\frac{L_0}{\text{dB}} = 29.0 \text{dB} + 20 \cdot \log \frac{d}{\text{km}} + 20 \cdot \log \frac{f}{\text{MHz}} \quad (3)$$

Next, the total radiated power P_T of such a small loop of w turns and area A respectively diameter D , which is tuned with a parallel capacitor, is deduced analogically to that of an electrical Hertzian dipole[4].

Assuming a spherical coordinate system, electric and magnetic intensities are

$$H_\vartheta = H_{\max} \cdot \sin\vartheta = \frac{2 \cdot \pi \cdot w \cdot A}{\lambda} \cdot \frac{I}{2 \cdot \lambda} \cdot \frac{\sin\vartheta}{r} \cdot e^{-j \frac{2 \cdot \pi \cdot r}{\lambda}} \quad (4)$$

and

$$E_\varphi = E_{\max} \cdot \sin\vartheta = -\frac{\pi \cdot w \cdot A \cdot I}{\lambda^2} \cdot \frac{\sin\vartheta}{r} \cdot Z_0 \cdot e^{-j \frac{2 \cdot \pi \cdot r}{\lambda}} \quad (5)$$

related by the free-field characteristic impedance $Z_0 = 120 \cdot \pi \Omega$ as

$$E_\varphi = -Z_0 \cdot H_\vartheta \quad (6)$$

The surface integral of the power density S yields the total radiated power P_T

$$P_T = \iint S \cdot dO = \frac{1}{2} \cdot \iint E_\varphi \cdot H_\vartheta \cdot dO = \frac{1}{2} \cdot \iint \frac{E_\varphi^2}{Z_0} \cdot dO \quad (7)$$

Substitution of the electric intensity (5) and solving the integral yields

$$P_T = \frac{E_{\max}^2}{Z_0} \cdot \int_0^\pi \sin^2 \vartheta \cdot 2 \cdot \pi \cdot r \cdot \sin \vartheta \cdot r \cdot d\vartheta = 2 \cdot \pi \cdot r^2 \cdot \frac{E_{\max}^2}{Z_0} \cdot \int_0^\pi \sin^3 \vartheta \cdot d\vartheta = \frac{8}{3} \cdot \pi \cdot r^2 \cdot \frac{E_{\max}^2}{Z_0} \quad (8)$$

with

$$E_{\max} = \frac{2 \cdot \pi \cdot w \cdot A}{\lambda} \cdot \frac{I}{2 \cdot \lambda} \cdot \frac{1}{r} \cdot Z_0 \cdot e^{-j \cdot \frac{2 \cdot \pi \cdot r}{\lambda}} \quad (9)$$

and

$$|E_{\max}| = \frac{\pi \cdot w \cdot A}{\lambda^2} \cdot \frac{I}{r} \cdot Z_0 \quad (10)$$

Hence

$$P_T = \frac{8 \cdot \pi^3 \cdot w^2 \cdot A^2 \cdot I^2 \cdot Z_0}{3 \cdot \lambda^4} \quad (11)$$

The quality factor, Q , of the resonant circuit determines the resonance step-up of the loop current. With the impressed output current, I_T , from the transmitter to the antenna, the effective loop current is equal to

$$I = I_T \cdot Q \quad (12)$$

Furthermore, the area A of the circular loop with a diameter D is

$$A = \frac{\pi \cdot D^2}{4} \quad (13)$$

Herewith we get

$$P_T = \frac{\pi^5 \cdot w^2 \cdot Z_0}{6} \cdot \left(\frac{D}{\lambda}\right)^4 \cdot I_T^2 \cdot Q^2 \quad (14)$$

Substituting P_T from (14) in (1), we derive

$$P_R = \frac{\pi^5 \cdot w^2 \cdot Z_0}{6} \cdot \left(\frac{D}{\lambda}\right)^4 \cdot I_T^2 \cdot Q^2 \cdot \frac{\lambda^2 \cdot G_T \cdot G_R}{(4 \cdot \pi \cdot d)^2} \quad (15)$$

and with the assumption $G_T = G_R = 1.5$ (two small single turn loop aerials) finally

$$P_R = \frac{3 \cdot \pi^3 \cdot w^2 \cdot Z_0}{128 \cdot d^2} \cdot \frac{D^4}{\lambda^2} \cdot I_T^2 \cdot Q^2 \quad (16)$$

As we can see from this formula, received power is directly proportional to Q^2 and D^4 , whereas inversely proportional to λ^2 . This equation is only valid, if the diameter D of the loop is small compared to the wavelength λ . Furthermore, Q is not independent of D and λ . Particularly losses due to skin effect increase with frequency and reduce Q . Therefore owing to circumstances a practical optimum does exist.

Quality factor Q of the loop antenna

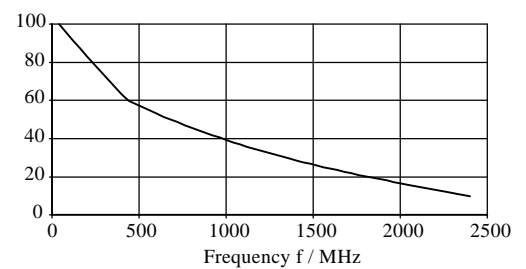

Figure 44 Assumed quality factor of a loop antenna versus frequency

Exemplary, the total transmitted and received power will be calculated at 40 MHz, 433.92 MHz and 2400 MHz, because these are frequently used bands. The corresponding Q values are roughly estimated to 100, 60 and 10. Assuming $D = 1$ cm and $I_T = 2$ mA, the transmitted power, P_T , at the above mentioned frequencies is -56, -19 and -5 dBm, whereas the received power P_R in a distance $d = 20$ m will be -83, -67 and -68 dBm respectively. This applies to free-space propagation and shows that higher frequencies are favorable when using such a small antenna. Figure 45 shows the dependence of the received power versus the loop diameter, D , and the frequency, f , at a fixed distance $d = 20$ m. The assumed quality factor, Q , of a loop antenna versus frequency is drawn in figure 44.

ANT012

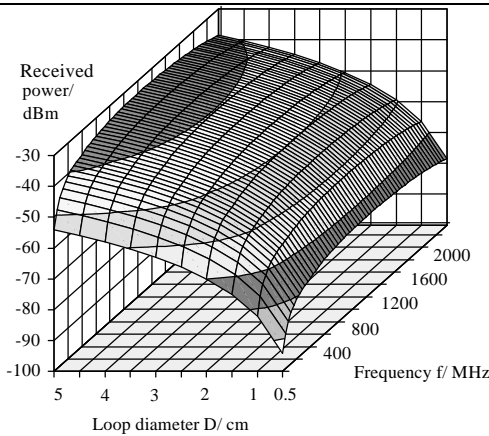

Figure 45 Received power P_R at a distance $d = 20$ m versus frequency f and antenna loop diameter D

In practical operation, some additional factors influence the propagation characteristic. Diffraction and reflection of radio waves at edges and conductive surfaces as well as their capability to penetrate dielectric materials is frequency dependent. RF is shielded by metallic structures if the size of the gaps and slots of the structure are small compared to the wavelength. This fosters higher frequencies as well. On the other side, if one bears in mind, that propagation losses due to H_2O absorption and reflections by dielectric layers (e.g. window panes) are increasing rapidly at frequencies above 2 GHz, the UHF range reveals to be the best frequency choice for our purposes. Moreover, the low absorption of radio waves in the UHF band by H_2O molecules is beneficial because this pays regard to human protection.

Let us now regard the radiation characteristic of a small loop aerial. According to [4], such a loop's inductance is

$$L = 2 \cdot \pi \cdot D \cdot \ln\left(\frac{\pi \cdot D}{a} - K_2\right) \cdot 10^{-9} \quad (17)$$

The constant K_2 is determined by the geometry of the loop. Taking a circular loop it is $K_2 = 1.07$, for a quadratic loop $K_2 = 1.47$ and finally $K_2 = 1.81$ for a equilateral triangular loop according to [4].

We consider the circular loop with a wire gauge $a = 0.5$ mm and therefore its circumference, \bullet is

$$\bullet = \pi \cdot D \quad (18)$$

Equation (17) is only valid for $\frac{\bullet}{a} > 50$. This boundary condition implies that the constant K_2 has almost no influence on the inductance L and therefore in this regard the geometry of the aerial is quite uncritical.

As mentioned before the effective radiated power is essentially determined by the loop current and the resonance step up of this current in such a parallel resonance circuit is a function of the quality factor, Q .

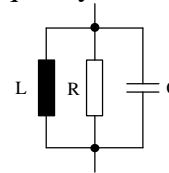

Figure 46 Equivalent circuit of the tuned loop antenna. The capacitance C and the equivalent shunt resistance R are

$$C = \frac{1}{(2 \cdot \pi \cdot f_0)^2 \cdot L} \quad (19)$$

and

$$R = \frac{Q}{2 \cdot \pi \cdot f_0 \cdot C} = 2 \cdot \pi \cdot f_0 \cdot L \cdot Q \quad (20)$$

Figure 47 shows the characteristic of L , C and R for a circular loop with a wire gauge $a = 0.5$ mm versus the loop diameter D .

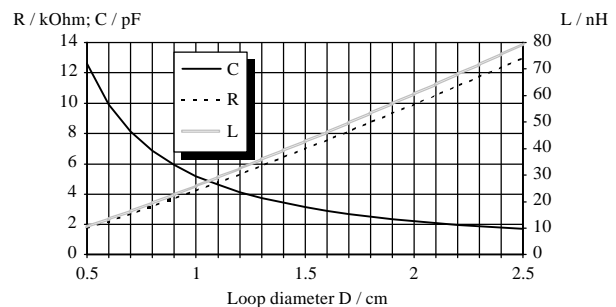

Figure 47 C , R , L for a loop antenna at $f_0 = 433.92$ MHz versus D for $Q = 60$

The effective loop current I_0 at the operating frequency f_0 is:

$$I_0 = I_{T0} \cdot \frac{1}{\sqrt{\left[\left(\frac{2 \cdot \pi \cdot f_0 \cdot L}{R}\right)^2 + \left[(2 \cdot \pi \cdot f_0)^2 \cdot L \cdot C - 1\right]^2\right]}} \quad (21)$$

with the resonance step up factor

$$V_0 = \frac{I_0}{I_{T0}} \quad (22)$$

respectively

$$V_0 / \text{dB} = 20 \cdot \log(V_0) \quad (23)$$

As shown in equation (12) the effective loop current at the fundamental frequency is $I = I_T \cdot Q$, therefore $V_0 = Q$.

The effective loop current at the n-th harmonic we get from the following equation (24):

$$I_n = I_{Tn} \cdot \frac{1}{\sqrt{\left[\left(\frac{2 \cdot \pi \cdot (n+1) \cdot f_0 \cdot L}{R}\right)^2 + \left[(2 \cdot \pi \cdot (n+1) \cdot f_0)^2 \cdot L \cdot C - 1\right]^2\right]}}$$

with the resonance step up factor

$$V_n = \frac{I_n}{I_{Tn}} \quad (25)$$

respectively

$$V_n / \text{dB} = 20 \cdot \log(V_n) \quad (26)$$

The relation between the impressed and the effective loop current at the fundamental and the first two harmonic frequencies is plotted in figure 48. It is assumed an operation frequency $f_0 = 433.92$ MHz and a quality factor $Q = 60$.

I_n / mA

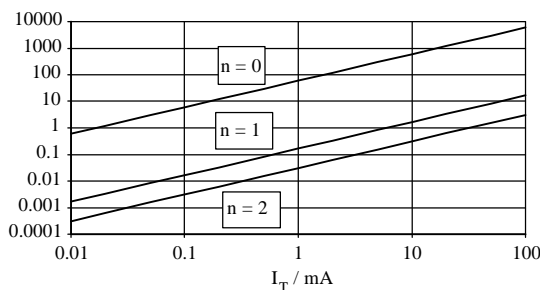

Figure 48 Effective loop current I_0 at $f_0 = 433.92$ MHz and the harmonics at f_1 and f_2 versus the impressed loop current I_T for $Q = 60$

Finally we will regard the effective radiated power of a loop antenna at the fundamental wave and the harmonics. In regard of the fundamental wave we derive

$$P_0 = \frac{\pi^5 \cdot w^2 \cdot Z_0}{6} \cdot \left(\frac{D}{\lambda_0}\right)^4 \cdot I_0 \quad (27)$$

and referring to the n-th harmonic we deduce analogously

$$P_n = \frac{\pi^5 \cdot w^2 \cdot Z_0}{6} \cdot \left(\frac{D}{\frac{1}{n+1} \cdot \lambda_0}\right)^4 \cdot I_n \quad (28)$$

We have to bear in mind that all equations are only valid for $D \ll \lambda$. Among others the radiation pattern at higher harmonics is not quasi isotropic.

Substituting the equations (17), (19), (20), (21), (24) into equations (27), (28), assuming

$$I_{Tn} = \frac{I_{T0}}{2^n} \quad (29)$$

we derive the subsequently shown three diagrams figures 49, 50, 51.

P_n / dBm

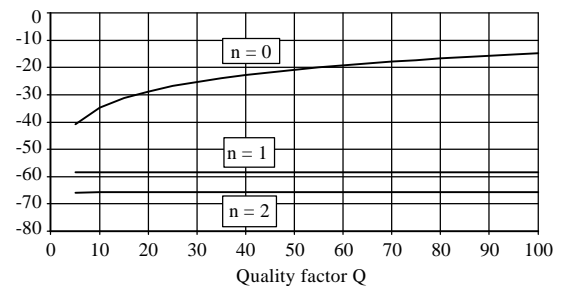

Figure 49 Radiated power at $f_0 = 433.92$ MHz and harmonics versus Q for $I_T = 2$ mA, $D = 1$ cm

P_n / dBm

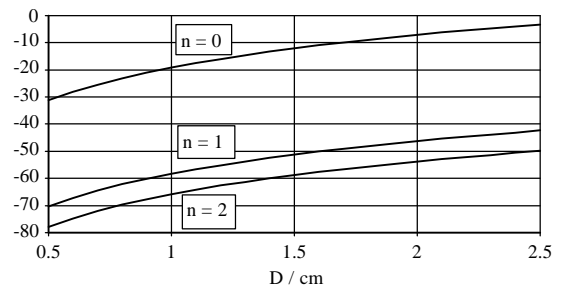

Figure 50 Radiated power at $f_0 = 433.92$ MHz and harmonics versus D for $I_T = 2$ mA, $Q = 60$

ANT012

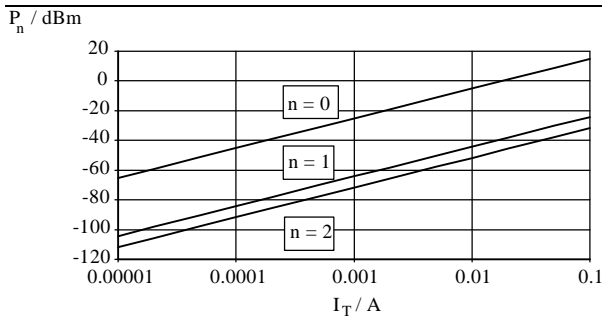

Figure 51 Radiated power at $f_0 = 433.92$ MHz and harmonics versus I_T for $D = 1$ cm, $Q = 60$

It can be seen, that for $f_0 = 433.92$ MHz, $D = 1$ cm, $I_T = 2$ mA, $Q = 60$ the radiated

power at the fundamental wave is approximately -19 dBm, at the first harmonic -58 dBm and at the second harmonic -66 dBm. Therefore the suppression of the first harmonic is 39 dB whereas 47 dB at the second harmonic. Concluding, once more it has to be emphasized that the previous considerations were based on several approximations and simplifications. Nevertheless the results are in good accordance with our practical investigations. At least they are well suited to appraise individual practical results and to deduce possible objects of optimization.

References

- [1] Tietze, Schenk
Halbleiter Schaltungstechnik
Springer-Verlag Berlin 1986, edition 8, pp. 404-405
- [2] Boese, Gebauer
Kombiniertes Funksende- und -empfangsgerät mit einer PLL-Schaltung
Patent pending, reference P4201415.8
- [3] Meinke, Gundlach
Taschenbuch der Hochfrequenztechnik
Springer-Verlag Berlin 1986, Vol. 1, H4
- [4] Zinke, Brunswig
Lehrbuch der Hochfrequenztechnik
Springer-Verlag Berlin 1986, Vol. 1, pp. 339-346
- [5] Lüke
Signalübertragung
Springer-Verlag Berlin 4th edition 1990, pp. 167-197
- [6] Niestroj, Zapsky, Lang
Kostengünstige und zuverlässige Fernsteuerungen durch OFW Resonatoren
Siemens Components 4/90, pp. 142-145
- [7] Vollers jr.
General-purpose SAW resonator oscillator for 300MHz to 1000 MHz
RF Monolithics Inc. 1984, Application Note No. 3
- [8] Bopp, Strohal
A Low Current UHF Remote Control System Using a SAW based Superhet Receiver
Presented at the Wireless Symposium and Exhibition in San Jose, California, 1993
- [9] Bopp, Strohal
UHF Remote Control Systems: Front End and Complete Receiver Design
TEMIC TELEFUNKEN Application Note, Issue 7, 94