



ST1331, ST1333 ST1335, ST1336

Memory Card IC 272 bit High Endurance EEPROM With Advanced Security Mechanisms

DATA BRIEFING

- Single Supply Voltage (5 V)
- Memory Divided into:
 - 16 bits of Chip Identification
 - 48 bits of Card Identification
 - 40 bits of Count Data
 - 16 bits for Validation Certificate
 - 24 bits of Transport Code
 - 64 bits of Authentication Secret Key (ST1333/35) / Issuer Data (ST1331/36)
 - 32 bits of Anti-tearing Flags (option)
 - 56 bits of User Data (option: not erasable)
- Counting Capability (two options)
 - up to 32767 ($8^5 - 1$)
 - 8 times Reloadable, up to 4095 ($8^4 - 1$)
- Certificate for Card Validation
- Advanced Authentication Function (ST1333/35)
- Special Anti-Tearing Mechanism
- Circuit Protected by Transport Code for Delivery from ST to the Card Issuer
- Reset on V_{CC} High and Low
- Choice of Two Communication Protocols:
 - 6 contacts for ST1331 and ST1333
 - 5 contacts for ST1335 and ST1336
- E.S.D. Protection Greater Than 4000 V
- 1 Million Erase/Write Cycle (minimum)
- 10 Year Data Retention (minimum)
- 5 ms Programming Time (maximum)

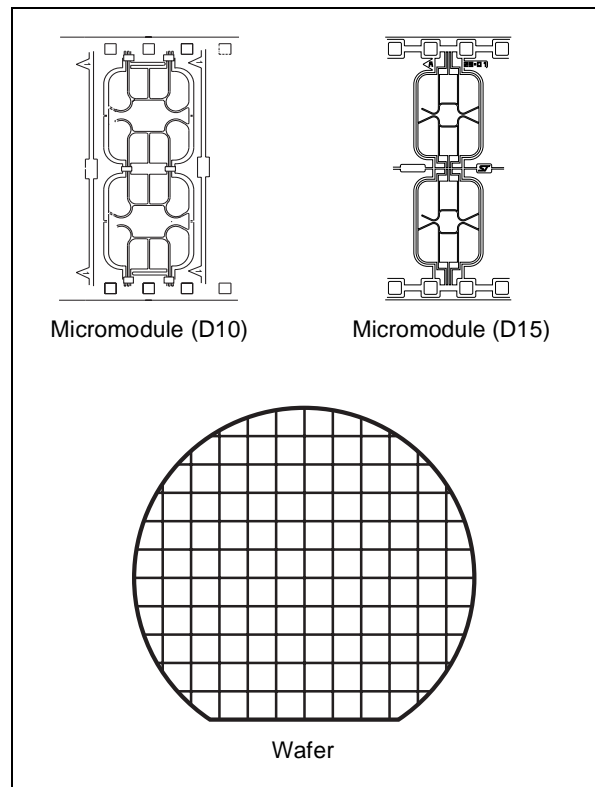

Table 1. Signal Names

CLK	Clock
RST	Function code for ST1331/33
	Reset for ST1335/36
B	Function Code for ST1331/33
I/O	Data Input / Output
V _{CC}	Supply Voltage
GND	Ground

Figure 1. Logic Diagram

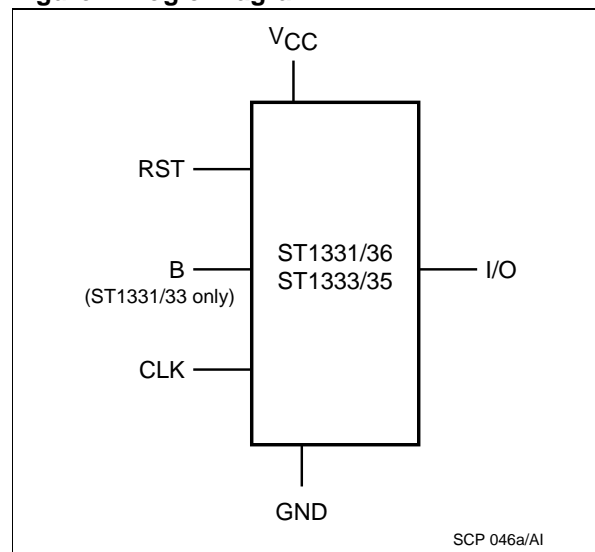
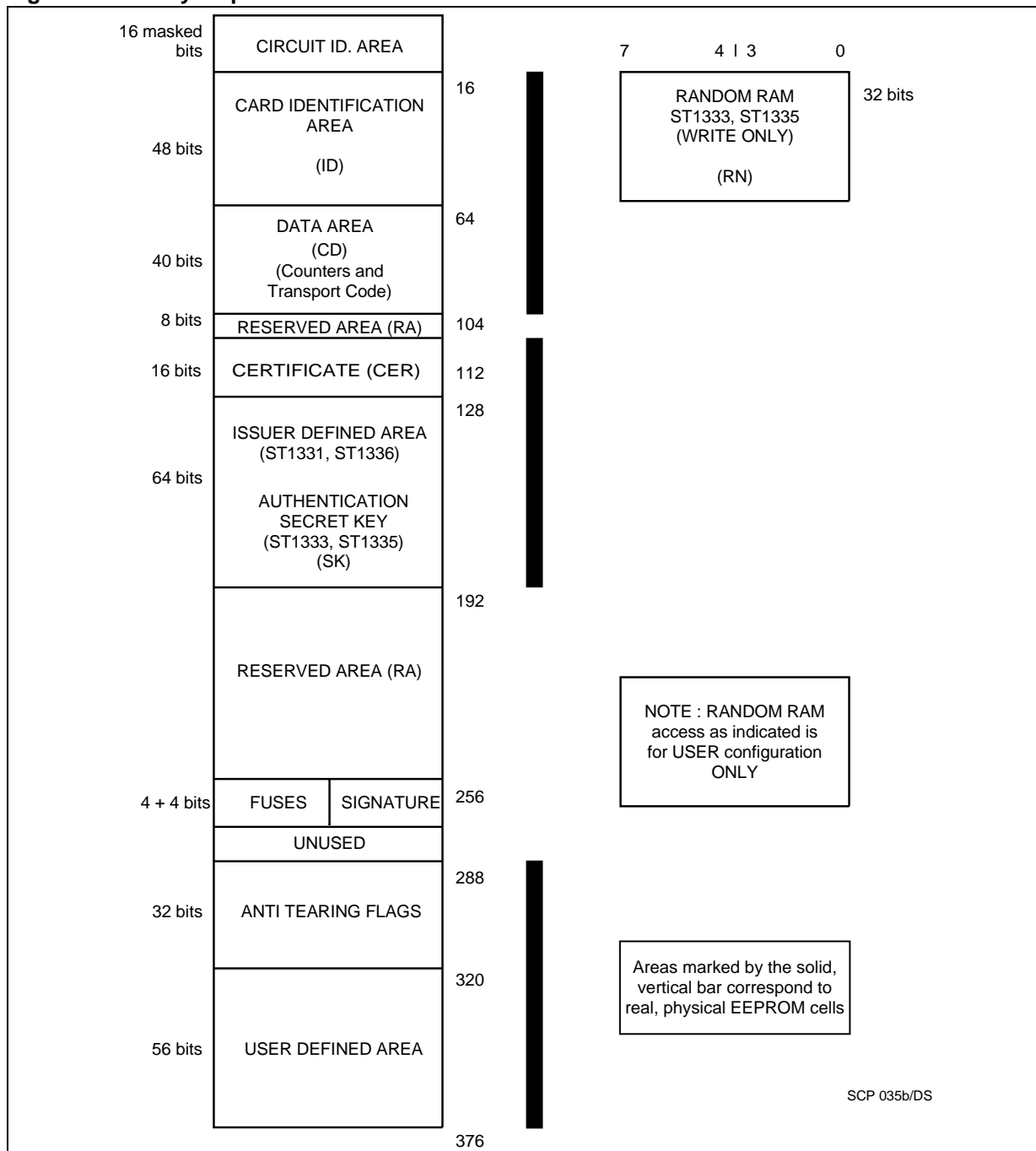

Figure 2. Memory Map



DESCRIPTION

The members of the ST133x family are principally designed for use in prepaid telephone card applications. They consist of 272 bits of EEPROM, with associated hard-wired security logic and special fuses to control memory access. The memory is arranged as a matrix of 34 x 8 cells, accessed in a serial bit-wise fashion for reading and program-

ming, and in a byte-wise fashion for internal erasing. An on-chip address counter provides an internal address space of up to 512 bits.

Each chip has an identification data area, counters (with an anti-tearing mechanism for reliable usage in open readers), a post validation certificate, an issuer area (ST1331/36) or an authentication secret key area (ST1333/35), and a user area. The

validation certificate allows the recognition of the circuit by the appropriate security module.

The anti-tearing mechanism guards against extra, spurious count signals being executed when the card is unexpectedly extracted, while an operation is underway, in an open reader.

Each device works in two distinct configurations:

- Issuer Configuration: for the card manufacturer. Customised data can be written to the chip, to initialise it before release to the end user
- User Configuration: for the end user of the card, with restricted access to the chip

Three options can be chosen on ordering:

- The anti-tearing mechanism can be disconnected. In this case, the anti-tearing flag area from bit 288d to bit 319d is unused (see Figure 2 on the previous page).
- The user area, from bit 320d to bit 375d, can be defined as "not erasable" in the User Configuration.
- The reload mechanism can be activated. In this case, erasing a bit in the reload counter refreshes the certificate (CER).

EXTERNAL COMMANDS

The device recognises four commands issued via the external pins:

- RESET: to reset the internal address register to 000d
- READ: to increment the internal address register and read the data bit at the new address
- COMPARE: to allow comparison of the presented code against the internal transport code
- PROGRAM: to program the bit at the current address

These commands are encoded either as a five- or six-contact protocol, according to the device type:

- Five-contact protocol used by ST1335 and ST1336, using VCC, GND, I/O, CLK, RST
- Six-contact protocol used by ST1331 and ST1333, using the additional B contact.

Table 2. ST133x Family Products

Product	Advanced Authentication function	Communication Protocol	
		6 contacts	5 contacts
ST1331		Yes	
ST1333	Yes	Yes	
ST1335	Yes		Yes
ST1336			Yes

Table 3. Ordering Information Scheme

