

# TM-75/76 High-Resolution CCD Camera

**PULNiX**  
Imaging Products



## General Description

The TM-75/TM-76 camera offers a high-resolution interline transfer 1/2" CCD imager in a small package. The camera's form factor, pinout, timing, shuttering, and mounting holes are designed specifically as a replacement for the popular Sony XC-75 (TM-75) or XC-75CE (TM-76). This makes the camera an excellent alternative in major machine vision systems where the XC-75 is qualified.

The front end of the camera measures 44mm by 29mm, and the length is 91mm including connector. All circuit boards are securely integrated inside the camera to assure the most robust design for the most demanding applications.

The TM-75/TM-76 camera is available in two formats: EIA (TM-75) and CCIR (TM-76). It has many standard and optional features at a very affordable price. In a departure from the common practice of using a standard CCD and its chipset, the TM-75/TM-76 uses a PULNiX-proprietary timing generator chip. This allows the TM-75/TM-76 camera to be used as a base model for highly specialized custom-designed cameras with non-standard options for OEM users.

Manual Gain Control (MGC) is easily accessible on the camera's rear panel.

Electronic shuttering is another standard feature with continuous or asynchronous reset-restart modes. Fourteen shutter speeds, ranging from 1/60 sec. to 1/29,000 sec., can be selected using the rotary switch in combination with a DIP switch inside the camera.

These cameras fit easily, both physically and functionally, into all types of machine vision, automated inspection, and related applications. Other uses include remotely piloted vehicles, miniature inspection devices, surveillance, microscopes and medical equipment.

## TM-75/TM-76 Spectral Response

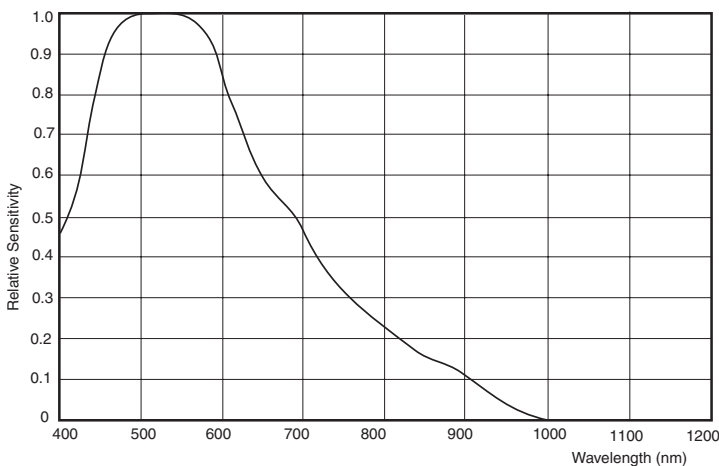

## TM-75/76 Features

- Designed as a replacement for Sony XC-75 (TM-75) or XC-75CE (TM-76)
- High-resolution 1/2" format CCD
  - TM-75: 768 H x 494 V (EIA)
  - TM-76: 752 H x 582 V (CCIR)
- Mini size 44 (W) x 29 (H) x 91 (L) mm
- Advanced Hyper-HAD™\* interline transfer CCD
- Shutter from 1/60 to 1/29,000 (continuous and async)
- Externally adjustable manual gain control and automatic gain control (AGC)
- External sync, async reset-restart, variable async trigger shutter
- Custom and OEM models available

## Operating Modes

The TM-75/TM-76 operates in the following modes, each of which can be selected using the switches inside the camera.

- ① Standard Interlace Mode
  - Field Integration
  - Frame Integration
- ② External Sync (HD,VD input) Mode
- ③ Interlace and Non-Interlace Operation Mode
- ④ Cyclic (Continuous) Shutter Mode
- ⑤ Snapshot Electronic Shutter Mode
- ⑥ Reset-Restart Operation Mode
  - Field Integration Mode
  - Frame Integration Mode
- ⑦ Reset-Restart Mode with External Shutter Control
  - Trigger Pulse Position Control Mode
  - Trigger Pulse Width Control Mode

\*Hyper-HAD is a registered trademark of SONY Corporation.

TM-75/76

# TM-75/76 High-Resolution CCD Camera

## Operating Modes (Continued)

### 1 Standard Interlace Operation

#### Field mode and Frame mode

The field and frame integration mode is selectable. The frame integration is used to separate all CCD pixels and the exposure of Odd and Even fields generates the full-frame image shown in the figure below.

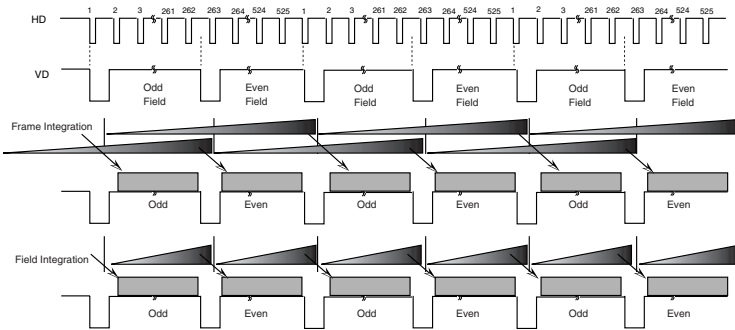

### Field Mode Binning

Field integration is done by combining two pixel rows (binning) together and each pair alternates as interlace scan is generated. In field 1, row 1 is binned with row 2, and row 3 is binned with row 4. In Field 2, row 2 is binned with row 3, row 4 with row 5, and so on. Field mode is very effective in shutter mode because the pixel sensitivity is doubled for field integration (1/60 sec) and equals with frame mode (one row at 1/30 sec). Since shutter mode is only one field output per shutter and darker than normal image, two-row binning is effective. This mode also reduces interlace moire when a sharp horizontal pattern is observed. For higher pixel definition such as gauging and sub-pixel interpolation, Frame mode operation is recommended.

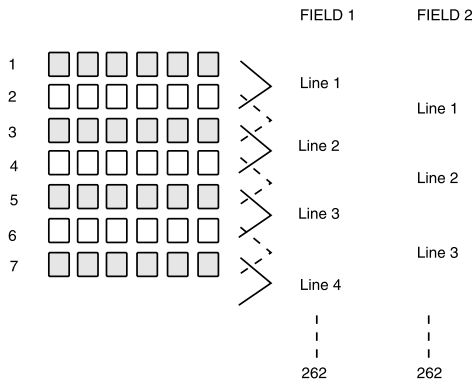

### 2 External Sync

TM-75/TM-76 accepts standard RS-170 external sync, which is defined as horizontal sync (HD) and vertical sync (VD). The phase-locked loop jitter is designed to be the minimum (< 5ns) in this category using the latest PLL chip. The wide capture range enables the camera to operate at an extended temperature range (optional) of -35°C to 65°C. HD and VD input is TTL level and the impedance is 75Ω and the trigger input impedance is 100Ω.

### 3 Non-Interlace Operation

With external sync of non-interlace, the camera operates at non-interlace scanning. External VD must be generated at integer of 262/312H ± 8H. (Standard interlace is 262.5/312.5 H)

### 4 Cyclic (Continuous) Shutter Mode

With in-housing shutter control, the TM-75/TM-76 operates at the internally predefined shutter speeds. Each field output is exposed for the same period. The shutter control varies the substrate discharge timing. The duration between the shutter pulse and transfer gate timing (9.5H from VD edge) decides the exposure time. (14.5H for CCIR)

### 5 External Trigger (Snapshot Shutter) Shutter

By supplying Trigger pulse into pin #9, the camera can be reset the shutter timing to capture moving objects without delay. This is similar function as Donpisha Mode. The shutter pulse is immediately generated from the external trigger without delay. The shutter exposure time is defined between the external trigger rising edge and internal transfer gate timing, which is 9.5H (14.5H for TM-76) behind of VD leading edge. It is effective to be used with Reset-Restart mode.

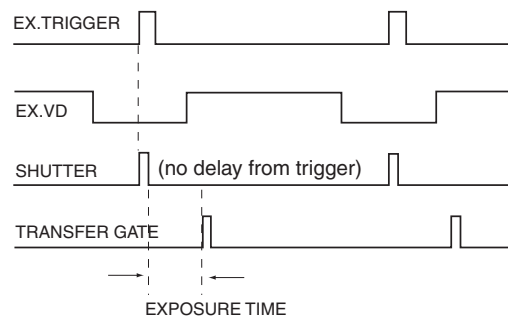

### 6 Reset-Restart Mode

Rather than using VINIT type async reset, the camera can be asynchronously reset using external VD (RR VD). In this mode, the camera needs multiple VD pulses to output valid images depending on whether it is set to Field or Frame Mode. Usually, the First Field (Field Mode) or the First Frame (Frame Mode) is unusable because it is the previous signals residual prior to reset. A frame grabber has to know which frame or field to capture. External HD must be applied for this operation. In order to select the Reset-Restart Mode, internal F2 switch is set ON (OFF position is for external VD Reset).

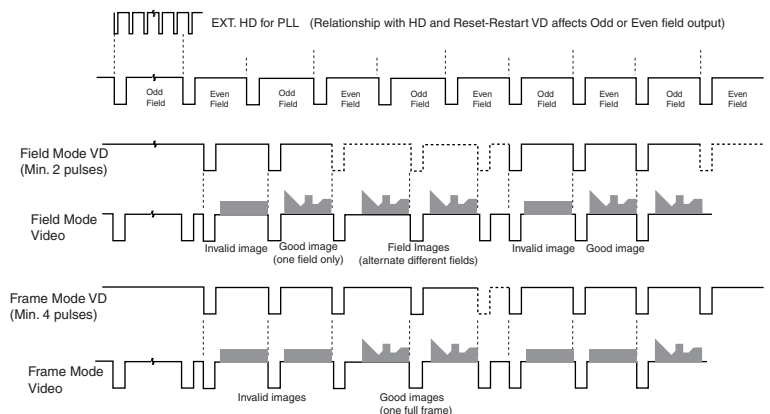

# TM-75/76 High-Resolution CCD Camera

## Operating Modes (Continued)

### ⑦ Reset-Restart with External Shutter Control

The shutter speed or exposure can be controlled with external pulse control in this mode. There are two modes of external trigger control.

#### 7-1. Trigger pulse position mode

By selecting RR-Trigger position mode, the shutter speed control is defined between the rising edge of trigger and internal transfer gate (9.5H from RR VD; 14.5H for TM-76).

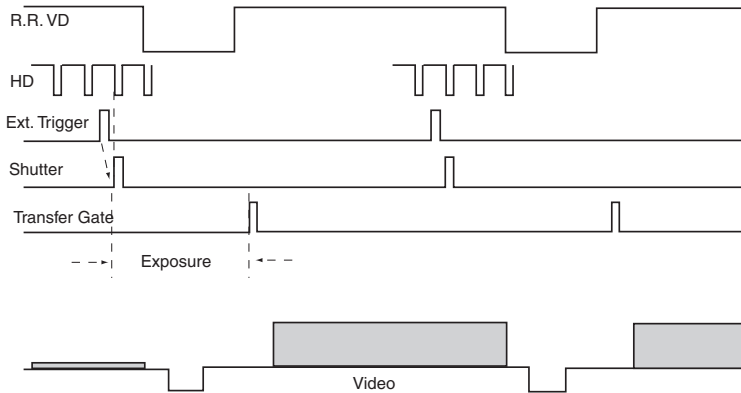

#### 7-2. Trigger pulse width control

By selecting RR-Trigger width mode, the shutter speed is defined between the rising edge and falling edge of the trigger pulse. The exposure timing can be random inside of one Vertical period and the video output is synchronized with RR VD.

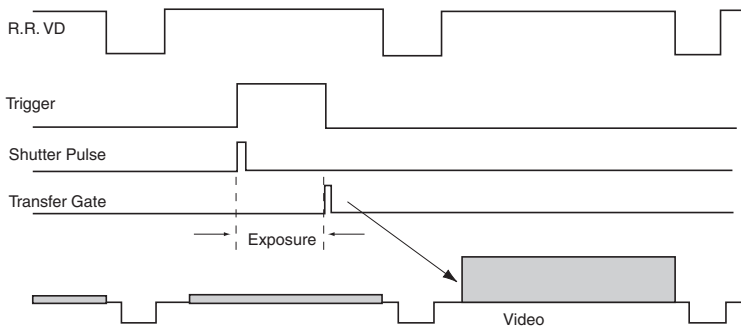

This is an excellent application for capturing multiple images (two fields of images) of indexing objects under various lighting or brightness conditions. When frame mode is selected, the full vertical resolution is achieved even when using an electronic shutter by taking two fields of shutter images.

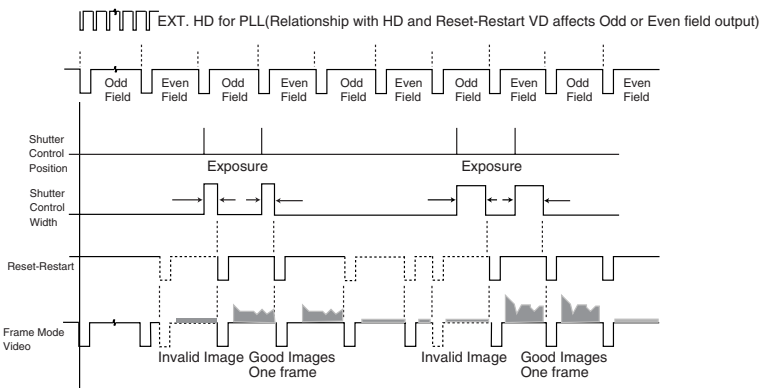

### ⑧ Mode Selections

#### Gamma selection:

Default: 1.0 (linear) or 0.45

#### Gain control:

MGC (manual gain control) or AGC (automatic gain control)

#### Field / Frame:

FLD (Field integration) or FRM (Frame integration)

#### Shutter control:

Extrnal trigger pulse control or CYC (Continuous mode)

#### Function control:

Internal shutter mode, Reset-restart snapshot mode, Pulse position control mode, Pulse width control mode

### ⑨ Shutter Speed Control and Functions

The following functions are available by setting a rotary switch and DIP switch inside camera.

Mode SW	Rotary SW	Shutter Speed	Trigger
FI	NO		
OFF	0	No shutter	
"	1	1/60	
"	2	1/100	
"	3	1/120	
"	4	1/250	
"	5	1/500	
"	6	1/1000	
"	7	1/1500	
"	8	1/2000	
"	9	1/2800	
"	A	1/3500	
"	B	1/4500	
"	C	1/6000	
"	D	1/10000	
"	E	1/29000	
ON	D	RR Snap-shot	Positive
"	E	RR Position	Positive
"	F	RR Width	Positive

### ⑩ Power Connector Pin Configurations

12P-02S Interface Cable (optional)			
Pin#	Lead Color	Function	Pin Configuration
1	Gray	GND	
2	Yellow	+12V DC	
3	Red coax shield	GND	
4	Red coax	Video	
5	Orange coax shield	GND	
6	Orange coax	HD Input	
7	Black coax	VD Input	
8	White coax shield	GND	
9	White coax	TRIG input*	
10	Brown	N/C	
11	Blue	N/C	
12	Black coax shield	GND	
* TRIG is active high.			

# TM-75/76 High-Resolution CCD Camera

## Product Specifications

Model	TM-75 (EIA)	TM-76 (CCIR)
Imager	1/2" Interline transfer CCD, HAD type	
Pixel	768 (H) x 494 (V)	752 (H) x 582 (V)
Cell size	8.4 $\mu\text{m}$ x 9.8 $\mu\text{m}$	8.6 $\mu\text{m}$ x 8.3 $\mu\text{m}$
Scanning	525 lines	625 lines
Sync	Internal/External auto switch fH=15.734 KHz $\pm$ 5% fV=59.94 Hz	
TV resolution	570 (H) x 350 (V)	560 (H) x 420 (V)
S/N ratio	56 dB AGC off	
Min. illumination	0.5 lux (F=1.4)	
Video output	1.0 Vp-p composite video, 75 $\Omega$	
AGC	ON/OFF (OFF std)	
Gamma	Default: 1.0 (linear) or 0.45	
Lens mount	C-mount	
Power req.	190 mA @ 12V, 11-15V	
Operating temp.	-10° C to +50° C	
Vibration & shock	Vibration: 7Grms/20-2000 Hz; Shock: 70G	
Size (W X H X L)	44.0mm x 29.0mm x 91.1mm 1.75" x 1.188" x 3.59"	
Weight	104grms (3.7oz)	
Power cable	12P-02S (optional)	
Power supply	K25-12V, PD-12UU	P-15-1
Functional options	Optical filter removal (OP3-2); Glassless CCD imager (OP21); DC coupled (OP72); NIR CCD	
Accessories	See current price list	

## OEM Custom Cameras

Various versions of the OEM cameras are possible based on the TM-75 model. Some examples include:

- Near IR-sensitive CCD
- 2/3" CCD
- 1/3" CCD
- Remote head version
- Flying lead output (straight from back or right angle from side)
- Special timing and reset version
- Higher frame rate
- RS-232 or RS-485 control
- CS-mount front end

Please contact PULNiX if your application needs cameras with any of the above options.

## Cables

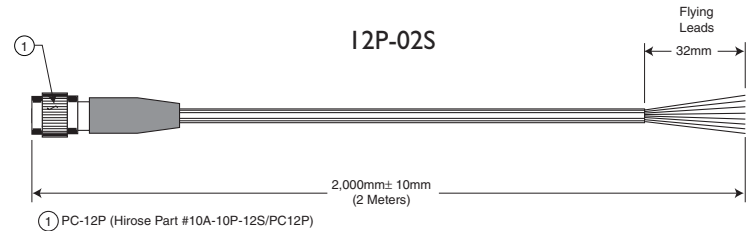

## Physical Dimensions

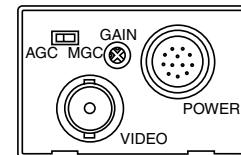
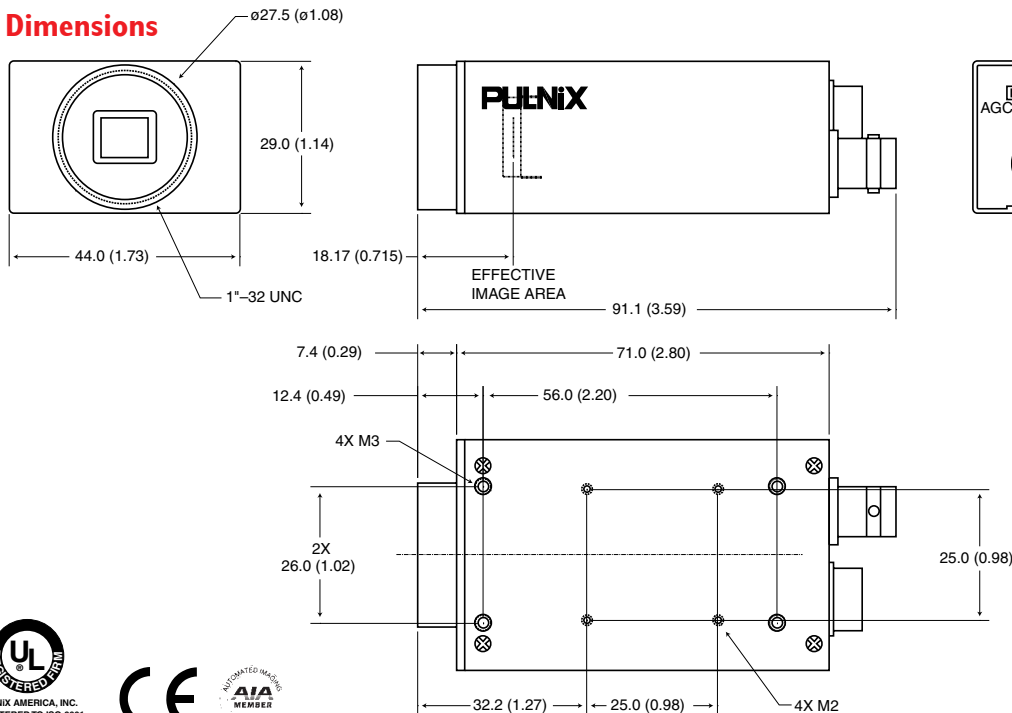

71-0047 Rev.A

TM-75/76



**PULNiX**  
Imaging Products

**Japan**  
PULNiX America, Inc.  
1-11-14 Hongo Bunkyo-ku,  
Tokyo 113-0033  
Tel: 81-3-5805-2455  
Fax: 81-3-5805-8082  
Kyoto Office:  
Tel: 81-75-594-6688  
Fax: 81-75-581-0102

**Australia**  
PULNiX America, Inc.  
Unit 16, #35 Garden Road  
Clayton, Victoria 3168  
Tel: 61-(0)3-9546-0222  
Fax: 61-(0)3-9562-4892

**United Kingdom**  
PULNiX Europe, Ltd.  
PULNiX House,  
Aviary Court, Wade Road  
Basingstoke, Hampshire  
RG24 8PE  
Tel: 44(0)1256-475555  
Fax: 44(0)1256-466268

**Germany**  
PULNiX Deutschland,  
GmbH.  
Siemensstrasse 12  
D-63755 Alzenau  
Germany  
Tel: 49(0)6023-9625-0  
Fax: 49(0)6023-9625-11

**PULNiX America, Inc.** Tel: 408-747-0300  
1330 Orleans Drive Tel: 800-445-5444  
Sunnyvale, CA 94089 Fax: 408-747-0660

www.pulnix.com  
email: [imaging@pulnix.com](mailto:imaging@pulnix.com)