

YOU NEED TO KNOW HOW COMPONENTS BEHAVE IN THE REAL WORLD AND WHAT THEIR LIMITATIONS MEAN IN TERMS OF EMI. SOME GUIDELINES IN PROPER COMPONENT SELECTION FOR EMI AND IN DESIGNING SIMPLE EMI FILTERS WILL HELP IN THE BATTLE.

EMI and circuit components: where the rubber meets the road

SOMEONE ONCE SAID, “The time to worry about EMI is when you mix the silicon.” Not all components are made of silicon, and most of us don’t get to work at that level, but the saying does remind us that most EMI problems begin or end at an electronic component.

Even if you can’t work inside the chip, you can work near the chip, preventing unwanted energy from entering or escaping from it. You have three options: intercept the energy at the chip, at the circuit board, or at the enclosure. When dealing with emissions and immunity, the closer you can get to the source or victim component, the fewer holes you need to plug. You call this approach “source suppression” when dealing with emissions and “circuit hardening” when dealing with immunity.

Many designers assume that individual components won’t cause EMI problems. After all, a capacitor is a capacitor at all frequencies, right? (Same with an inductor.) And one vendor’s ICs are the same as another vendor’s ICs. They have the same part number—they must be the same. If you believe these statements, then you are in for some real fun with EMI.

EMI AND ICs

Interference ultimately begins and ends with an IC. In practice, almost all IC interference is conducted in or out via the pins, although as speeds increase, you might also see direct radiation to and from the chips. Although interference can go into or out of any pin, in practice, output pins tend to produce emissions and input pins tend to be

vulnerable to interference. Voltage and ground pins can be involved in either case.

EMI involves both analog and digital circuits but often in different ways. Digital circuits are likely emission sources (thanks to harmonics) and are vulnerable to spiky interference, such as ESD or EFT (electrically fast transient). Analog circuits, such as audio or instrumentation circuits, are more likely victims, particularly to RFI. Bandwidth is a common thread in both types of circuits (due to increased edge rates and silicon geometries) and has increased drastically in recent years. (This bandwidth is often much higher than you actually need.)

Digital circuits are often rich sources of emissions, thanks to fast clock rates and edge rates. The primary sources for emissions are the clock circuits and traces or other highly repetitive signals, such as buses. Common design solutions are small filters on critical lines.

Another major source of digital emissions is the high-frequency current pulses on the V_{CC} lines. These V_{CC} pulses are often considered the “back door” for emissions, and you can assume that any

Figure 1

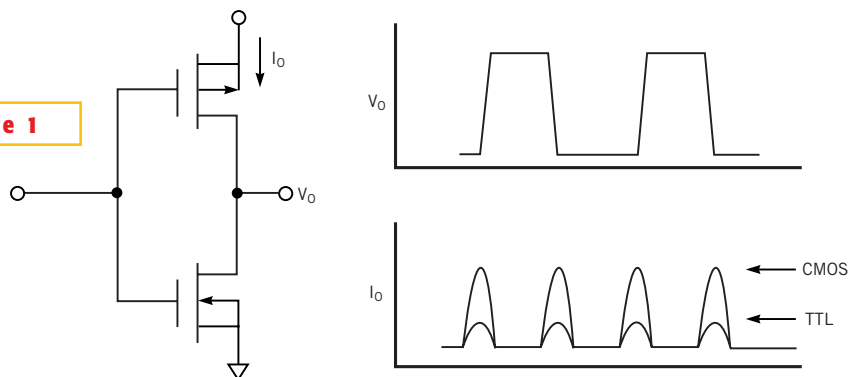

High-frequency current pulses are a big problem on CMOS devices because of high shoot-through or delta-I currents.

This article is part of an upcoming 14-chapter guide to electromagnetic compatibility. Stay tuned for more.

clocked device (source, destination, or intermediate buffer) has these V_{CC} pulses. In recent years, they've worsened on CMOS devices because of the higher shoot-through or delta-I currents (Figure 1). In the old days of TTL and HMOS, the average currents were higher, but the peak currents were lower. These CMOS spikes are due to N-channel and P-channel transistors being on simultaneously for a short time during switching. This inherent characteristic of CMOS devices is a major contributor to digital emissions. The design solution is to ensure adequate high-frequency decoupling on all clocked devices.

A common sneak path for emissions is high-frequency interference riding piggy-back on other pins sharing the same package. This path is subtle, but it happens. (How many times have you heard, "But it can't be that line...it doesn't even switch.") Factors that contribute to this phenomenon include crosstalk in the chip or bond wires, common impedance coupling in the lead frame/ground pins, and voltage/ground bounce in the chip. Unfortunately, you can't get inside the chips, but you can take precautions outside the chip. For instance, don't allow lines from clocked devices (such as μ Cs) to leave the board without going through a filter or buffer circuit. Or, add ferrites or other filters to supposedly quiet lines.

Analog circuits, on the other hand, are usually well-behaved for emissions. Emissions problems always involve a periodic wave (such as a clock or data bus), and because most analog devices do not involve periodic waves, the devices are normally not emissions sources. In the past few years, however, there have been several cases of parasitic emissions from analog devices. The emissions usually occur in the 200- to 400-MHz range and are not clock-harmonic related. Rather, parasitic feedback (and a gain greater than one at the feedback frequency) causes them. The common solution is to add

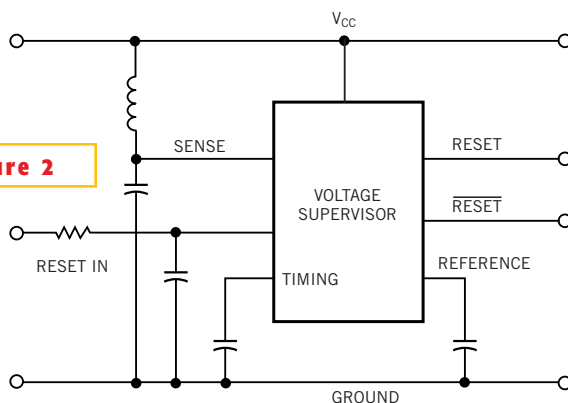

Figure 2

Make sure to protect power-monitoring devices against ESD.

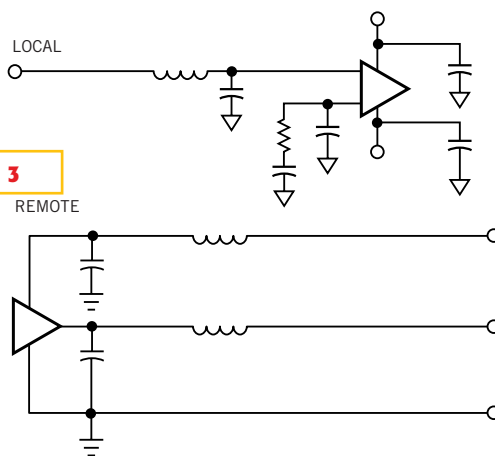

Figure 3

Protect analog circuits from RFI. Remember, low-frequency circuits can be upset by high-frequency EMI.

high-frequency filtering and decoupling to "low-frequency" analog circuits. This high-frequency filtering also helps combat RF-immunity problems.

ESD

Digital circuits are particularly vulnerable to ESD and its cousin, EFT. In fact, digital circuits are vulnerable to any spiky interference that's large enough at the circuit level to flip a bit in a memory, a microprocessor, or any digital circuit. The problem has become severe in the past 10 years, as digital edge rates fell below about 2 nsec. Because the typical ESD pulse has a nominal edge rate of 1 nsec, the typical ESD noise at the circuit level is often about 2 nsec wide (1 nsec rise/1 nsec fall). When digital circuits had 5- to 10-nsec edge rates, ICs usually had a built-in ESD filter on every pin, but

that's no longer the case. The ESD window of susceptibility has been opened wide for almost all ICs today.

You often need to slow circuit response to ESD. To accomplish this goal, add small filters (1000-pF capacitors or 1000-pF capacitors and ferrites) at critical inputs, such as reset lines or read/write control lines. Incidentally, power-monitor or reset controller devices are particularly vulnerable to ESD if you don't take these precautions. These useful devices are fast, and ESD can drive them into a false reset. At minimum, be sure that high-frequency decoupling is in place at the V_{CC} , particularly if it's also the power-down reference. If you have an external reference pin or an external reset switch, make sure to filter them against ESD (Figure 2).

Analog circuits, on the other hand, are not very vulnerable to ESD because of relatively low bandwidth. (They are vulnerable to damage, of course, just like any other circuit exposed to high-voltage levels.) Looking for a 1-nsec response to a circuit with 1000 Hz of bandwidth is like looking for a power-line spike with an old-fashioned voltmeter with a meter movement. The bandwidth is just too low.

However, ESD causes an interesting analog effect. It doesn't happen often, but when it does, it's often judged a nuisance rather than a failure. After an ESD event, a meter may wiggle for several seconds or a video display may momentarily shrink and then return to full size. Both events are due to long time constants in filter circuits that actually stretch the effects of the ESD event.

Digital circuits are relatively robust against RF. Analog circuits, however, are vulnerable to RF. Don't be lulled into a false sense of security by assuming your low-frequency audio or sensor circuit won't respond to high-frequency radio sources—drive your amplifier hard enough and it will become an RF detector, rectifying the interference and de-

modulating it. Think about what happens to your input circuit looking for a 20-mV audio frequency signal when it's faced with 2V at 150 MHz: Your system looks like a crystal radio.

Analog circuits fail at electric field levels of 0.1V/m or less, but most digital circuits are unaffected at 10V/m or more. Unfortunately, typical field levels from surrounding transmitters can easily be in the 1 to 10V/m range and can reach 100V/m or more for severe cases. Unless you take design precautions, you have a threat that can far exceed analog-circuit-vulnerability levels.

The secret is to include high-frequency filtering and decoupling in your low-frequency analog and instrumentation circuits. **Figure 3** shows an example for an analog receiver circuit and a remote sensor. Don't forget to also provide high-frequency protection on your voltage regulators. Put 1000-pF capacitors close to the inputs and outputs, with very short leads.

Most digital and analog circuits are relatively unaffected by power disturbances. The power supply usually takes the brunt of these disturbances and isolates the internal circuits. There are, however, two exceptions:

- Some EFT energy often gets through the power supply, due to the fast edge rates (5 nsec, which look like about 60 MHz) and high levels (several thousand volts.) Digital circuits, such as resets or control lines, are particularly vulnerable to EFT. Fortunately, the ESD protection that this article recommends also mitigates this problem.
- Long-term sags can result in modulation of poorly regulated analog circuits. This event can happen in a system using the battery as a voltage regulator. As the batteries age, the internal resistance increases, which results in less voltage regulation. The solution is to simply add a small regulator circuit for the vulnerable analog circuits.

DEALING WITH PASSIVE COMPONENTS

Obviously, active circuits can contribute to EMI problems, but what about simple passive devices? They may not actually cause EMI problems, but if poorly selected or installed, they can certainly contribute to them. A number of com-

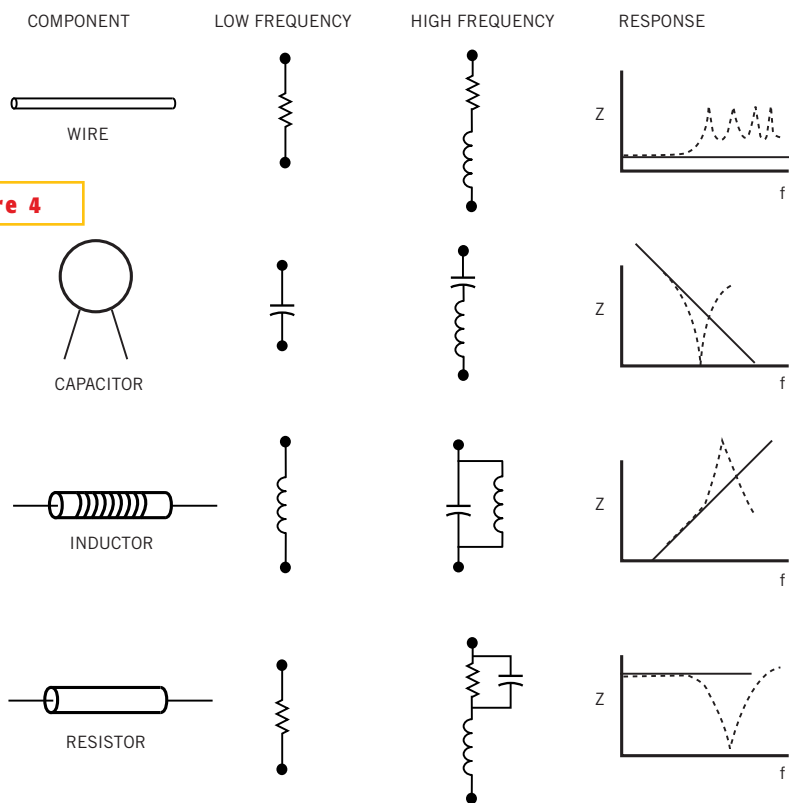

Figure 4

When dealing with passives, the higher the frequency, the more likely hidden-schematic effects will be an issue.

ponents are used solely for EMI issues, such as transient protectors, optical isolators, and isolation transformers.

Most EMI problems with passive components are exceptions to the rules. When is a capacitor not a capacitor? When it's a high-frequency inductor caused by internal inductance in the component or external inductance in the leads. When is an inductor not an inductor? When it's a capacitor, due to high-frequency parasitic coupling between the windings. Even traces and wires can get into the act, becoming high-frequency antennas. The secret is to understand the component limitations and then design to accommodate those limitations.

These exceptions are referred to as the "hidden schematic" (**Figure 4**). Note that these undesired effects are frequency-dependent. The higher the frequency, the more likely the hidden-schematic effects will cause problems.

Wires and traces are normally not considered components (they just intercon-

nect various circuit elements, right?) But all wire and pc-board traces have inductance that becomes significant at relatively low frequencies and that must be considered as part of any component description.

As a rule of thumb, assume that 1 in. of wire or pc-board trace has an inductance of about 20 nH/in. Metric-system users often use 10 nH/cm, which is about 25 nH/in. Does it matter? The inductance usually varies from 15 to 30 nH/in., so either works. Theoretical purists might argue that an inductor must be a closed loop, but that approach clouds the issue. The approach works well for understanding EMI issues. It is based on "partial inductances," a concept introduced by respected EMC research scientist and author Dr Clayton Paul.

Because of self-inductance, the inductive reactance of a wire or trace can exceed the self-resistance at a surprisingly low frequency, which generally occurs somewhere around 10 kHz, although it varies due to wire size. Thus, a trace or

wire is inductive at greater than about 10 kHz (Figure 4). Is this inductance a problem? Well, using the rule of thumb, even a 1-in. wire at 100 MHz has an impedance of about 12Ω. If you're trying to provide a high-frequency short, a 1-in. piece of wire might not work.

How do you reduce that inductance? You can fatten it into a strap, or in the ultimate case, you can go to an "infinite plane," but this approach is impossible in the real world. However, a solid ground or power plane on a board could be a decent approximation of that ideal infinite plane. That's why straps and planes are good for high-frequency designs. In another method, you can move the trace or wire close to its return, which reduces the total inductance caused by mutual inductance effects. For example, a trace over a plane typically has about one-third the inductance (or about 7 nH/in.) of a wire or trace in free space—another reason multilayer boards are useful for high frequency.

At higher frequencies, the wire or trace starts to look like an antenna. Another rule of thumb is the one-twentieth wavelength rule, which simply says that any wire or trace (or cable, or other component) can become an efficient antenna at a physical distance of one-twentieth of a wavelength or more. At 100 MHz, that's about 6 in., and it decreases to about 3/4 in. at 1 GHz. That antenna effect accounts for the shape of the traces at high frequencies in Figure 4.

For EMI, you use capacitors for signal filtering and voltage-supply decoupling.

Figure 5

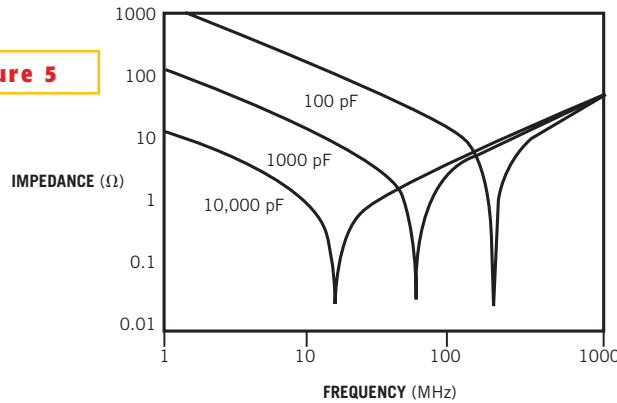

NOTES:
CAPACITOR IMPEDANCE FOR 1/2-IN. LEAD LENGTH (10 nH).

High-frequency performance is primarily determined by lead length.

The main concern when using capacitors is the high-frequency performance—harmonics included. At the highest frequencies, few capacitors are up to the task, but fortunately, ceramic capacitors are well-behaved into the gigahertz range. As such, they're the device of choice for high-frequency filtering and decoupling.

The primary limitation of EMI capacitor performance is resonance due to either internal or external inductance. Internal inductance usually limits larger capacitors, such as electrolytics. Table 1 shows typical capacitor-frequency limitations; it assumes no lead length, which further degrades the frequency response.

For high-frequency capacitors, the external lead length can be a problem. But you can control this parameter. Figure 5 shows the effects of lead lengths on a 0.01-μF capacitor. Note that even 1/2 in. of lead length (10 nH) results in a resonance at about 16 MHz. Above that frequency, the capacitor is an inductor! Incidentally, being above the resonant frequency is not fatal, but the more you can do to lower the inductance and raise the resonant frequency, the lower the shunt impedance at high frequencies.

How much capacitance do you need? As a matter of practicality, a good goal is a capacitive reactance of 0.1 to 1Ω at the frequencies of concern. Internal resistance will probably limit anything lower than 0.1Ω. You can calculate the value using the classical formula, $X_c=1/(2\pi fC)$, which is a bit of a pain. A quick method, called the "rule of one," is that if

$\mu F \times MHz=1$, then $X_c=0.16\Omega$ (and if $\mu F \times MHz=0.1$, then $X_c=1.6\Omega$). Thus, for 100 MHz, a 0.001- to 0.01-μF capacitor would be appropriate, and at 1 MHz, you would need a 0.1- to 1-μF capacitor.

In any event, you can't achieve these low values at high frequencies unless you keep the lead lengths short, and that means the entire path length from node to node. Leaded capacitors usually have at least 1/2 in. of total lead length

for an inductance of about 10 nH. Surface-mount capacitors are much better, but the nature of SMT (surface-mount technology) is that the component solder pad is not the via. They may actually be some distance apart, adding undesirable inductance to the path. With SMT capacitors on multilayer boards, assume about 7 nH/in. for trace length, as discussed earlier.

As a side concern, remember that a good decoupling capacitor shunts copious amounts of high-frequency emission currents. So beware when placing the components; any sensitive traces in the rear of the decapacitor might be subject to magnetic field pickup.

You can use wound inductors and ferrites for EMI. The wound inductors typically range from about 1 μH to 1 mH and are usually wound on a ferromagnetic slug or a nonmetallic coil form, depending on the amount of inductance needed. The slug, of course, will exhibit some loss characteristics.

The major concern with wirewound inductors is interwinding capacitance, resulting in a parallel resonance as shown in Figure 4. Like capacitor resonance, parallel resonance can occur at a much lower frequency than you would guess. Empirically, the resonant frequency can be estimated by $f_0=200/\sqrt{L}$, where f_0 is the resonant frequency in megahertz, and L is the inductance in microhenries. This formula works well whether or not the core is ferromagnetic.

As an example, a 100-μH inductor resonates at about 20 MHz; at greater than

TABLE 1—CAPACITOR SELECTION

TYPE	MAXIMUM FREQUENCY
ALUMINUM ELECTROLYTIC	100 kHz
TANTALUM ELECTROLYTIC	1 MHz
PAPER	5 MHz
MYLAR	10 MHz
POLYSTYRENE	500 MHz
MICA	500 MHz
CERAMIC	1 GHz

NOTE:
THESE VALUES ASSUME NO LEAD LENGTH, WHICH ADDITIONALLY DEGRADES THE OPERATING FREQUENCY DUE TO RESONANCES.

20 MHz, it becomes a capacitor. Certainly, such a device is useless at the common interference frequencies of 50 to 500 MHz. Thus, the wound inductor is primarily a low-frequency element.

For higher frequencies, use ferrites. Ferrites are also inductors, and they become lossy with frequency. In fact, you can take advantage of these losses, treating them more like resistors than inductors at high frequencies. One ferrite vendor even refers to EMI ferrites as “impeders.”

Ferrites are high-permeability materials comprising granulated ferrite materials and fired at high temperature as a ceramic. Their permeability means they require few windings to achieve a high inductance. In fact, many ferrites have only one turn, at which the conductor actually passes through the ferrite material. Thus, the associated capacitance is quite low, typically less than 1 pF, which results in much better high-frequency performance than the wound inductor.

A important EMI feature: As the frequency gets higher, the hysteresis losses become significant, and the ferrite starts acting like a resistor, actually absorbing energy and dissipating it as heat. The frequency range is greater than the useful inductor range, and as a result, it's best to operate ferrites in their resistive, rather than inductive, frequency range.

Ferrites come in various formulations, covering a variety of frequency ranges. It is important to select a ferrite that performs in your frequency range of interest. The most popular EMI formulation is nickel zinc, and it provides good resistive performance from about 30 to 1000 MHz. As a result, this material is ideal for emissions and immunity in that frequency range, as well as ESD (which is about 300 MHz.) The two most popular nomenclatures are Type 43 (Fair-Rite) or Type 28 (Steward); other vendors cross-reference their parts. Some modified formulations of these two (Types 44/29) are also becoming popular. They have similar magnetic characteristics but slightly higher breakdown voltages.

The Type 43/28 materials have a peak resistance of about 100 Ω and are relatively flat above this frequency. As such, most vendors give you the equivalent re-

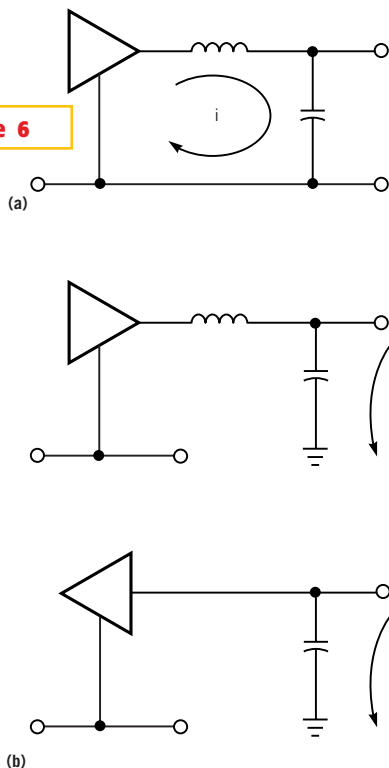

Figure 6

You can optimize an L filter to control emissions from a chip (a) or optimize it for immunity and common-mode emissions (b).

sistance at 100 MHz, which typically varies from about 50 to 500 Ω , depending on size and configuration. You can increase the resistance by adding multiple turns, but that option decreases the high-frequency response. Nevertheless, it can be useful if you need more ferrite impedance in the 50- to 200-MHz range. To minimize capacitive effects, limit the multiple turns to three.

Surface-mount ferrites provide a surprising amount of impedance for their size, as long as the current demands are low. SMT manufacturers have adapted multilayer-capacitor technology and route fine traces through the ferrite material. These ferrites have a much higher impedance than the older through-hole beads on leads, because they have a much longer path length inside the ferrite. But because they also have more windings inside, they have a higher interwinding capacitance, so the material often has a much higher Q than the beads on leads. Most surface-mount-ferrite manufacturers supply curves of impedance versus frequency, because the devices may not be flat above 100 MHz.

For effective ferrite performance, you typically need a ferrite impedance of 100 to 500 Ω . At less than 100 Ω , performance is limited, and at greater than 500 Ω , it is probably wasted. Ferrites can have impedances as high as 2500 Ω , but don't put them high on your list. The end-to-end capacitance of the ferrite probably limits the total impedance.

Current-limited surface-mount ferrites are really useful only for signals. DC-current distribution needs a higher current capacity, and such ferrites are lower in impedance. By the way, the current rating that the ferrite manufacturers give is a dc-current capacity and has nothing to do with impedance levels. If you put in the maximum current, the ferrite saturates and provides a lower impedance than you expected. Even so, ferrites are forgiving and don't lose all their impedance. They usually drop to about one-quarter, so ferrites are often derated to about 25% of unsaturated impedance for high-current applications.

Resistors have good points and bad points in terms of EMI. The good news is that it's easy to get a significant impedance, and the impedance is predictable over a wide frequency (and temperature) range. The bad news is their end-to-end capacitance often limits the overall impedance. Don't expect a 1-M Ω resistor to provide 1 M Ω at 100 MHz—it won't happen.

Modern surface-mount resistors are simple in construction, exhibiting minimal inductance and capacitance. As such, they behave pretty well up to about 500 MHz, where they ultimately succumb to internal parasitics. It is generally a good idea to use resistors instead of ferrites wherever your design can tolerate the voltage drop. Usually, this approach means signal lines, particularly unterminated ones. DC-power distribution usually cannot tolerate a voltage drop, so ferrites are preferred.

TRANSIENT PROTECTORS AND ISOLATORS

Several special components are usually installed solely for EMI protection.

Crowbar devices and clamp devices are two types of transient protectors. Both nonlinear devices do virtually nothing until the firing voltage is exceeded. By its very nature, a transient protector cannot

trigger at levels below the signal level. Thus, transient protectors cannot protect the signal level; they protect against over-stress, either overvoltage or overcurrent. As such, they should have little effect on normal signal levels.

Crowbar devices are usually gas-discharge tubes, but sometimes they're open-air devices. In either case, the transient voltage rises to a level sufficient to light an arc, then drops to a low-voltage/low-impedance state. As a result, crowbar devices can sink copious amounts of current, which makes them ideal for shunting lightning-transient currents or large power-transient currents. Unfortunately, the arc devices generally take 100 nsec or more to respond, making them ineffective EFT or ESD transients, so they're usually used for lightning protection on facility power or communications lines.

The two most common clamp devices are large-geometry zener diodes and MOVs (metal-oxide varistors). Zeners are fast and have a sharp cutoff, but they have limited energy-handling capability. MOVs have a soft cutoff and are a bit slower, but they can handle higher energy levels for the same size. Like arc devices, MOVs are not usually used for ESD, but they do work for the slightly slower EFT. You can find multilayer MOVs that have increased speeds and are useful for ESD on circuit boards and connector pins.

For maximum benefit, keep the lead lengths short on all shunt transient protection devices, just as you would for shunt capacitors at high frequency. Otherwise, the inductance may limit the performance. This approach is particularly important for ESD and EFT protection with 5- and 1-nsec rise times (or 60- and 300-MHz equivalent frequencies).

Optoisolators are often used in signal interfaces to break up ground loops. Optoisolators are good at this job, because they effectively pass the intended differential-mode signals while blocking the unintended common-mode currents (and resulting ground offset voltage) that can result from ground loops.

Optoisolators have limitations, however. First, they are ineffective high-voltage ESD barriers. Second, optoisolators are ineffective high-frequency barriers because of capacitance across the devices,

which, even when it is less than 10 pF, can be high enough to allow significant emissions to exit a port or significant RF energy to enter a port. The high voltage rating of the optoisolator, commonly 7 kV, is a hipot test and has nothing to do with ESD capability. High dv/dt from ESD will drive charge right through the isolator. For full protection, you might need additional high-frequency/ESD filtering, such as ferrites and small capacitors, on the opto input lines.

THE WHOLE PURPOSE OF USING FILTERS IN ELECTRONICS IS TO REJECT UNWANTED ENERGY, AND EMI CONTROL IS AN EXCELLENT APPLICATION OF THIS PRINCIPAL.

Isolation transformers are often used on both power and signal interfaces to provide low-frequency isolation against ground loops. Like optoisolators, the transformers are vulnerable to arcing and capacitive coupling across the windings due to ESD. For full high-frequency RF and ESD protection, you might need additional high-frequency filters (ferrites and capacitors).

Transformers may start to leak at much lower frequencies than optoisolators, so high-frequency filtering may not help at intermediate frequencies in the megahertz range, which unfortunately is where you find a lot of power transient energy. Again, transformers may require additional precautions.

Because filters in the megahertz range can get rather large, an alternative approach for isolation transformers is to add one or more Faraday shields. These devices are effective in the 1-MHz range,

often extending the filter-isolation performance well into tens of megahertz. The locations of the shields' connections depend on the shields' intended function. For common-mode isolation, the shield is connected to the chassis ground, and for differential-mode isolation, the shield is connected to the return (or power neutral) of the noise-source side of the transformer. You can use multiple shields.

SIMPLE EMI FILTERS

The final discussion is quick-and-dirty filter design for EMI. Filter design can quickly become complicated, but several conditions and assumptions let you greatly simplify filter design for most EMI applications. First, you usually only need relatively simple lowpass filters. Second, you usually don't need very tight frequency control (unlike a communications bandpass filter, for example). Third, you usually don't have controlled impedances, but for most digital circuits, the source impedance is low and the load impedance is high. As a result, you can take some quick-and-dirty design shortcuts that yield good results.

The whole purpose of using filters in electronics is to reject unwanted energy, and EMI control is an excellent application of this principal. You're trying to divert currents from an undesired path—either to prevent emissions from getting too far from the chip or to prevent external interference currents from getting to the chip. You can use a shunt element to divert currents off the line, series elements to block current on the line, or a combination of both. For a lowpass filter, the shunt element is a capacitor and the series elements are resistors, ferrites, inductors, or a combination of those devices.

The first question is which topology to use: a T, pi, or L filter? The answer lies in basic filter theory, which says that a maximum impedance discontinuity at each node is desirable. For a simple filter, see **Figure 6**, which shows an L filter, the preferred topology for a low-impedance driver and a high-impedance receiver. It makes no sense to put a low-impedance shunt capacitor across a low-impedance output device or to put a high-impedance series element in series with a high-impedance input device.

If you're unsure of the appropriate

topology, a T filter is usually a safe bet, although it may be more than you need. T filters are available in three-terminal SMT packages from major ferrite manufacturers and are useful for digital or analog I/O ports, because they can limit ESD or RF current dumped into the signal ground. For example, with a pi filter or an L filter on a driver, any energy on the I/O line is immediately shunted to the signal ground through the shunt capacitor. With the T filter, all external energy sees a series impedance first, thus limiting the current that might bounce the ground.

Whatever topology you select, always remember the main goal is to find filter elements that are functional at the desired frequency range. Breadboarding filters and testing them before attaching them to the actual circuit can help you determine performance.

After you've conquered the basics of filtering, make sure you follow the guidelines for EMI applications:

1. Identify the threat. Is your problem emissions-related, immunity-related, or both? If you have a clocked circuit, emissions are the big threat. Remember, the clock output driver, the clock noise on V_{CC} , or the rest of the output drivers sharing the same voltage bus can cause emissions problems. If your threat is immunity, transients typically cause digital-circuit problems, and RF is typically the culprit behind analog-circuit problems.

2. Select the protection strategy. If you want to protect the chip from damage, you may be looking at transient protection. If you're trying to frequency discriminate, filters are the answer.

3. Select the filter topology. Look for maximum impedance discontinuity at each node. If you're looking at a low-impedance driver and a high-impedance receiver, the best topology is an L filter. T filters are a good approach to I/O lines.

4. Select components to be functional at all problem frequencies. Make sure the

resonant frequency is not too low for your purposes. Be sure to factor in the pc-board lead inductance into your capacitor filters. □

AUTHORS' BIOGRAPHIES

Daryl Gerke received his BSEE from the University of Nebraska and has worked in the electronics industry for more than 25 years. He is a registered professional engineer, holds a master electrician's license, and is an active member of the IEEE. He is a principal in Kimmel Gerke Associates, a consulting firm that specializes in electromagnetic compatibility, with an emphasis on solving interference problems using proven troubleshooting techniques.

William Kimmel received his BSEE with distinction from the University of Minnesota and has worked in the electronics field for more than 30 years. He is a registered professional engineer, an active member of the IEEE, and a principal in Kimmel Gerke Associates.