

Edited by Bill Travis and Anne Watson Swager

Open-loop power supply delivers as much as 1W

Christophe Basso, On Semiconductor, Toulouse, Cedex, France

FOR VCRs, TVs, and other equipment that requires a standby mode, you must supply power to a μ P when other components are asleep to receive and interpret any wake-up signal from the remote control or from the broadcasting company. These types of systems have rather low power consumption, and classical switch-mode power-supply ICs represent a clear overkill for less-than-1W output levels. Any active power-supply circuit also needs to be more cost-effective than the standard structure using a metallic transformer. The circuit in **Figure 1** reduces the cost by eliminating the use of the optocoupler.

IC₁ directly drives an external 600V MOSFET. The lack of an auxiliary winding greatly simplifies the overall application circuitry; the controller's integrated dynamic self supply provides V_{CC}. IC₁ works as a peak-current PWM controller, combining fixed-frequency operation at 40, 60, or 100 kHz and the skip-cycle method for low standby-power consumption. IC₁ regulates the peak current

and allows operation over universal mains. Because the circuit operates at constant output power, the following formula determines the necessary peak current:

$$I_P = \sqrt{\frac{2 \cdot P_{OUT}}{L_P \cdot F_{OSC}}}$$

With an internal error amplifier that

Figure 1

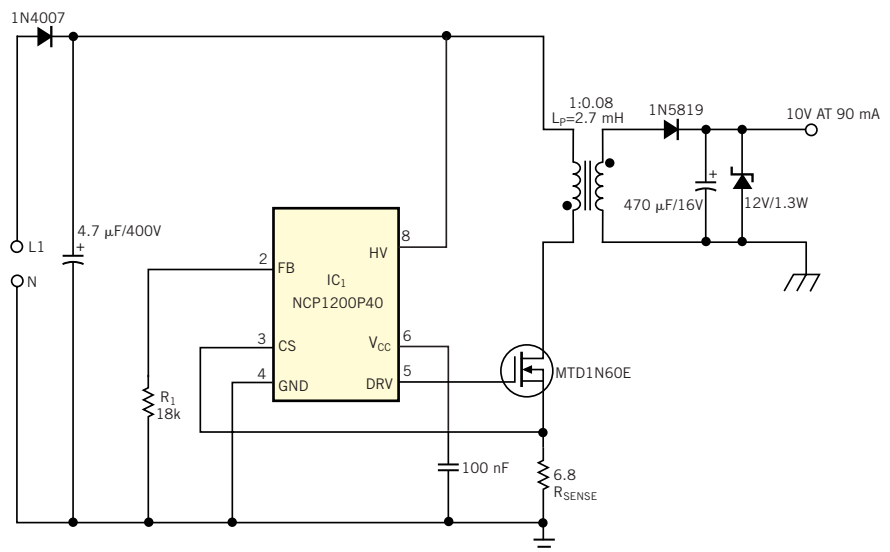

NOTE:
THE TRANSFORMER IS AVAILABLE FROM ELDOR (ELDOR@ELDOR.IT, REF 2262.0058C)
AND FROM COILCRAFT (INFO@COILCRAFT.COM REF Y8844-A).

IC₁ regulates the peak current and allows this 1W supply to operate from universal mains.

Figure 2

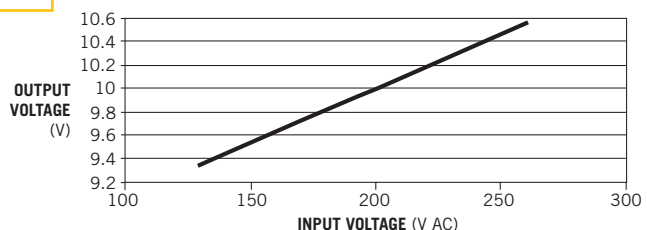

The input-voltage rejection stays within 1V from 130 to 260V ac.

Open-loop power supply delivers as much as 1W	143
Four-way remote control uses series transmission	144
Analyze LED characteristics with PSpice	150
Programmable-gain amplifier is low-cost	152
PC hardware monitor reports the weather	154

clips at 1V maximum, R_{SENSE} is equal to $1/I_p$ (maximum). In this example, a 40-kHz circuit and a 6.8Ω sense element deliver as much as 1W of continuous power with $L_p=2.8$ mH. You can recompute R_{SENSE} for lower or higher output-power requirements. The 12V zener diode prevents the circuit from generating over-voltages. R_1 deactivates the internal short-

circuit protection, which normally reacts upon feedback-path loss.

Thanks to its avalanche capability, the MTD1N60E requires no clipping network, which further eases the design. The efficiency measured 64% (low line, $P_{OUT}=866$ mW) and 61% (high line, $P_{OUT}=1.08$ W). **Figure 2** plots the input-voltage rejection, which stays within 1V

from 130 to 260V-ac mains. This **figure** illustrates current mode's inherent audio susceptibility.

Is this the best Design Idea in this issue? Vote at www.ednmag.com/ednmag/vote.asp.

Four-way remote control uses series transmission

JM Terrade, Clermont-Ferrand, France

A SIMULTANEOUS four-way remote-control system adheres to size, cost, and reduced-complexity constraints and uses a series transmission to drive parallel loads (**Figure 1**). You can use this system as long as the time constant of the load is much larger than the total transmission time for all data. With these considerations, this design can drive any object with four simultaneous controls as motors.

The design uses a 9-bit data packet. The emitter side of the design converts 4 data bits and a 5-bit ID code from parallel to serial. The data packet continuously transmits, and the total information arrives at the HF 433-

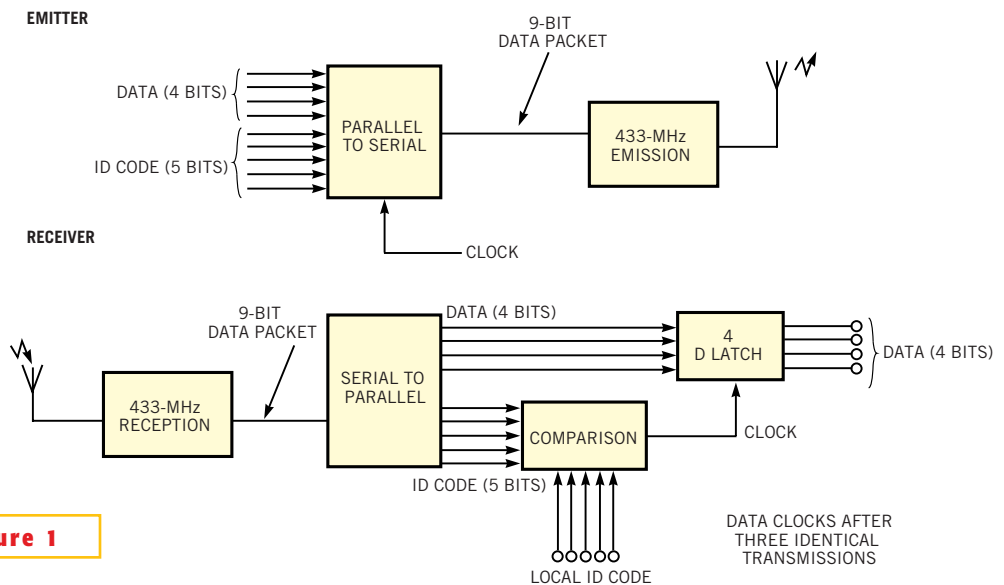

Figure 1

The emitter converts 4 data bits and 5 ID-code bits to serial data and continuously transmits the resulting data packet. The receiver compares the received ID code with the local code three times before clocking in new data.

MHz emitter. The receiver side converts the 9-bit serial data to parallel data. Then, the design compares the received ID code to the local code. The comparison result clocks the 4 data bits for the D latch. This configuration actually controls a small, battery-powered boat with two-way, remote-control switches. The switches are mom-off-mom types, which give front-stop-rear and left-center-right commands. The boat has two dc motors for

propulsion and direction. The transmission uses two 433-MHz, AM-radio modules for the HF link.

Power consumption is 10 mA during emission, so the emitter circuit can use a 9V battery (**Figure 2a**). D_1 protects the device against polarity inversion. S_1 and S_2 are three-position, mom-off-mom switches. Only the center, or null, position is static. The user must push the switch in one direction and maintain it to

keep the desired action. When released, the switch returns to its null position. With no action on S_1 and S_2 , the logic levels on data inputs D_6 to D_9 of IC_1 are low due to R_3 to R_6 . When an action occurs on S_1 or S_2 , the corresponding data input of IC_1 is close to 5V. You can activate S_1 and S_2 at same time. Voltage-divider pairs R_1 and R_3 or R_1 and R_4 and R_2 and R_5 or R_2 and R_6 produce acceptable levels for IC_1 inputs.

Diodes D_2 to D_5 permit C_1 to charge through R_7 . Then, Q_1 conducts, and Q_2 is on. D_6 acts as a power-on indicator. The voltage drop across D_6 , R_9 , and zener-diode D_7 results in a 5V supply for IC_1 and IC_2 . C_1 continuously charges until S_1 and S_2 return to the null position. Then, C_1 discharges through R_8 , and Q_1 switches off after approximately 8 to 10 sec (Figure 2b).

Inputs A_1 to A_5 of IC_1 are three-state inputs: low, high, and unconnected lev-

el. Thus, 243 combinations (3^5) are possible. However, three-state DIP switches are expensive, and 64 possibilities are enough for many applications. If Pin 6 of S_3 provides a low level, A_1 to A_3 can be either low levels or unconnected. If Pin 6 of S_3 provides a high level through R_{10} , A_1 to A_5 can be either high levels or unconnected. This arrangement gives 64 combinations.

R_{11} , R_{12} , and C_2 form the local oscillator. The output of IC_1 at Pin 15 provides

the 9-bit data packet to the HF emitter, IC_2 . The HF module uses amplitude modulation. The antenna is a 17-cm wire that attaches directly to the pc board. When the power is on, transmission always occurs. After a user releases S_1 and S_2 , the emitter continues to transmit the null-position information until power goes off, which takes approximately 8 sec.

On the receiver side (Figure 3a), the antenna is also a 17-cm wire attached directly to the pc board. The incoming sig-

Figure 2

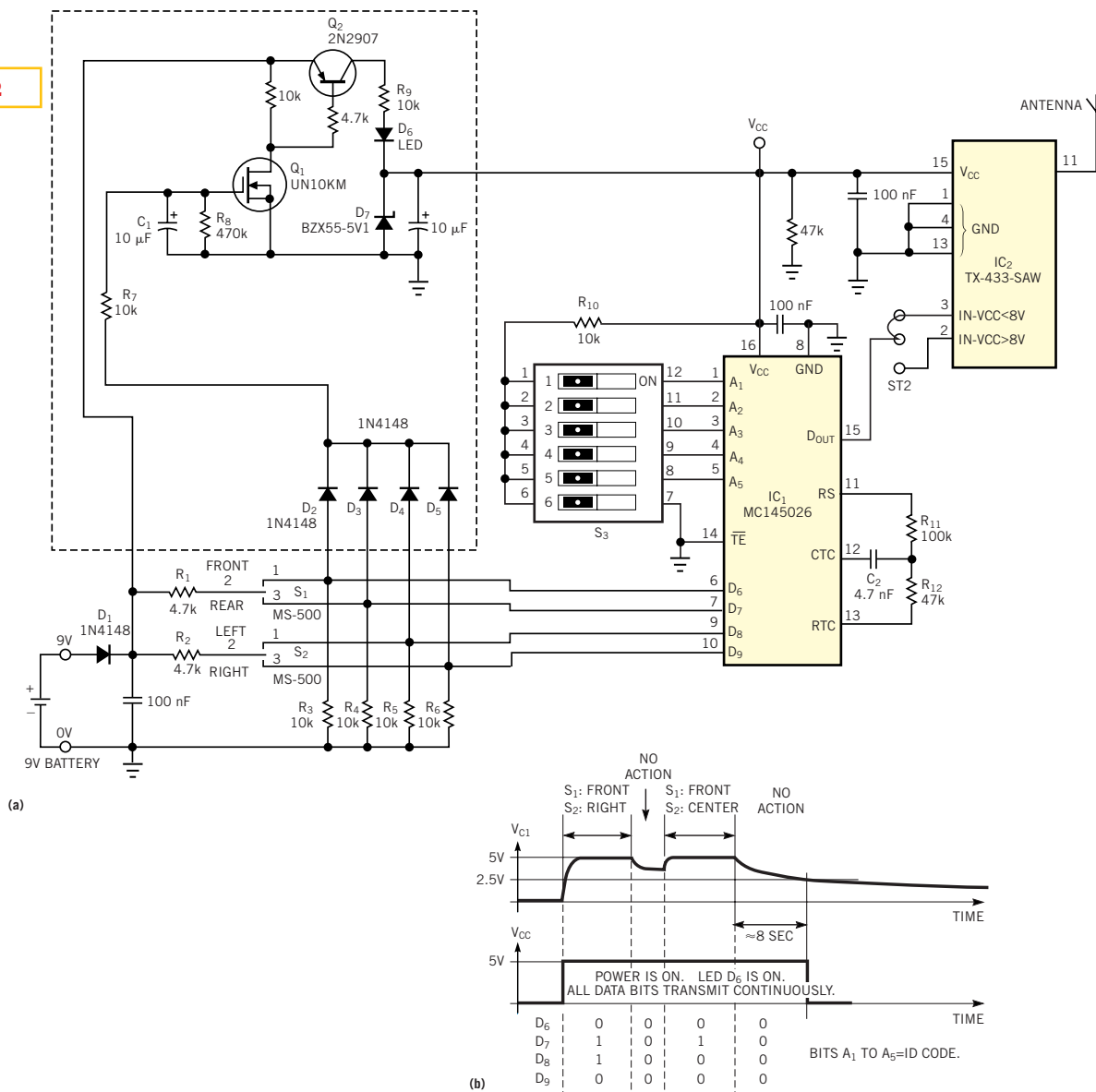

In the emitter circuit, two three-position switches, S_1 and S_2 , determine the voltage on C_1 (a) and the voltage levels of data bits D_6 to D_9 of IC_1 (b).

nal arrives at the HF module, IC₁, which has a stable 5V power source. The 9-bit data packet is available at the output, or Pin 14, of the module. Just as for the emitter, DIP switch S₁ provides as many as 64 possibilities for the ID code, and the setting must be the same combination as the emitter.

The 4 data bits are available at outputs D₆ to D₉ of IC₂. When a valid transmission arrives at the receiver, Pin 11 of IC₂ goes high. But each time a user changes the position of the commands on the emitter, the Valid-T signal goes low until

the new transmission is valid. Three correct transmissions are necessary. Therefore, the design needs a stable RX_OK signal, and, for this reason D₁, R₁, R₂, and C₁ create a time constant. The RX_OK signal goes low only when the transmission stops or when the ID code is invalid, which can happen if the emitter has no supply and stops emitting or if another transmitter is in the same area (Figure 3b).

The internal D latch, IC₂, clocks new output levels only when the circuit receives a new data packet. In this way,

when only one transmitted bit changes, the other bits keep their previous level. When the ID code is not valid or when the HF link is lost, which implies that the distance between the emitter and the receiver is too long, D₆ to D₉ keep their previous levels. However, RX_OK goes low after 70 msec and forces D₆ to D₉ to go low.

Is this the best Design Idea in this issue? Vote at www.ednmag.com/ednmag/vote.asp.

Figure 3

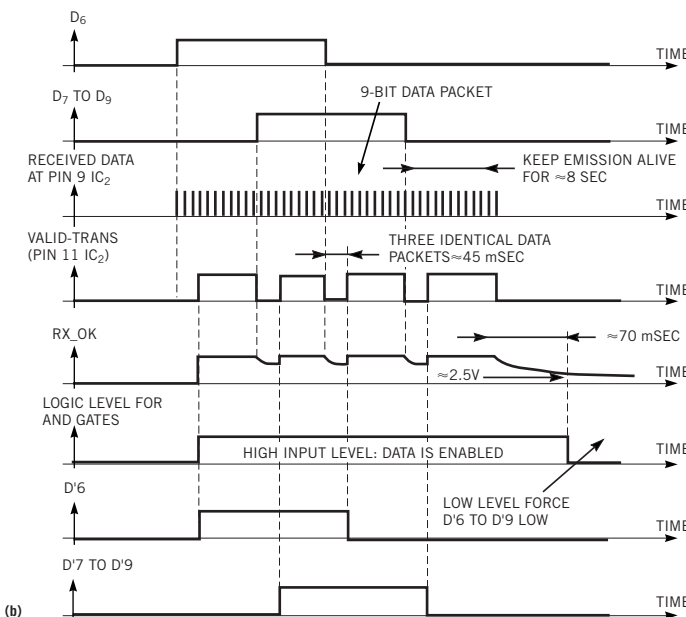
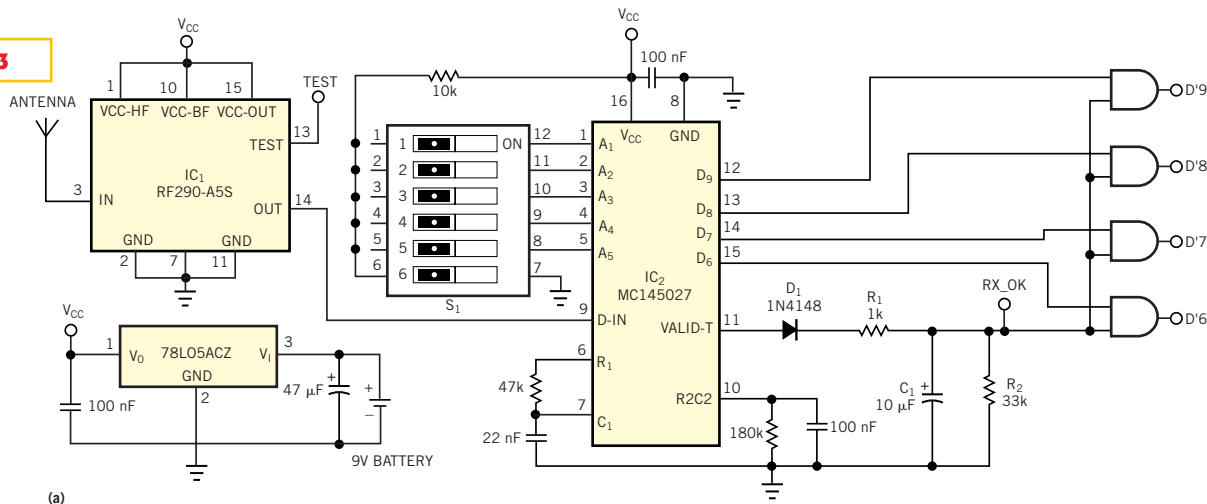

In the receiver (a), three correct transmissions must occur before Pin 11 of IC₂ goes high (b).

Analyze LED characteristics with PSpice

Sam Mollet, GE Harris Harmon Railway Technology, Grain Valley, MO

RECENT ADVANCES IN LED technology have led to LEDs' widespread use in outdoor-signal applications, such as in traffic and railroad signals. A typical LED signal consists of an LED array and a power supply. When a low-voltage power supply is either desirable or mandatory, series/parallel combinations of LEDs become inevitable. However, analyzing and optimizing series/parallel combinations of LEDs with varying forward characteristics can be complicated. Using the parametric and Monte Carlo capabilities of PSpice greatly simplifies this task.

To model an LED in PSpice, use the diode model. You can set the IFK and ISR parameters in the diode model to zero; **Figure 1** shows the resultant PSpice diode forward-current model and corresponding equations. As the equations in the **figure** show, you can express the forward voltage across the diode model, or V_{FWD} , as the sum of the voltage across the series resistance and the voltage across the intrinsic diode.

The dominant term in the V_{FWD} equation of **Figure 1**, assuming R_S is less than 10Ω , is the logarithmic term. Therefore, if you vary the model parameter N in Monte Carlo or parametric analyses, then the V_{FWD} varies accordingly. A helpful hint: When creating an LED model using programs such as Parts (www.microsim.com), use curve-tracer plots or an enlarged photocopy of the VI curve from data books to extrapolate data points along the VI curve.

Figure 2 shows an example for which N varies linearly between 2.07 and 2.53, or $2.3 \pm 10\%$. The forward voltage at 20 mA varies from 1.59 to 1.94V, or $1.765 \pm 9.9\%$. By editing the "N=2.3299" statement in the LED model to "N=2.3299 DEV 10%" assigns a 10% device tolerance to the LED model. Therefore, when you execute a Monte

Carlo analysis, the forward characteristics of each LED in the circuit vary randomly. **Figure 3's** example performs 20 Monte Carlo sweeps at 1V/sec, with N set for a 10% tolerance.

The final example is the analysis of a simple circuit (**Figure 4a**). The input consisted of a 60-mA

Figure 1

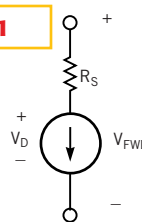

$$I_{FWD} = I_S \cdot (e^{V_D/N \cdot V_T} - 1)$$

$$V_D = N \cdot V_T \cdot \ln\left(\frac{I_{FWD}}{I_S} + 1\right)$$

$$V_{FWD} = I_{FWD} \cdot R_S + N \cdot V_T \cdot \ln\left(\frac{I_{FWD}}{I_S} + 1\right)$$

This simple model and equations are the result of setting PSpice's diode-model parameters IFK and ISR to zero.

LED Model:
 .MODEL LED_RED
 IS=5.5526E-15
 N=2.3299
 RS=2.2974
 CJO=2.9700E-12
 M=.3333
 VJ=.75
 BV=4
 IBV=10.000E-6
 TT=4.3200E-6

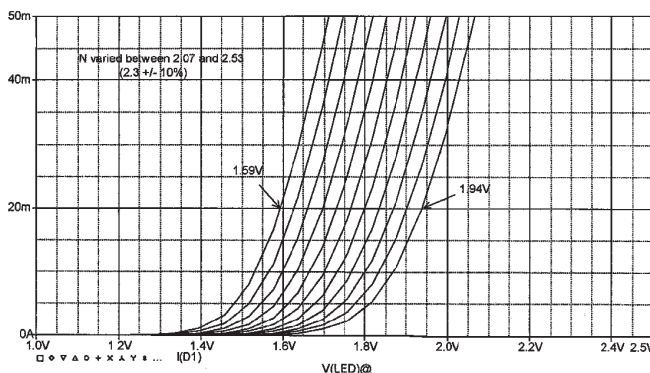

Figure 2

This simulation run varies N linearly from 2.07 to 2.53.

LED Model:
 .MODEL LED_RED
 IS=5.5526E-15
 N=2.3299 DEV 10%
 RS=2.2974
 CJO=2.9700E-12
 M=.3333
 VJ=.75
 BV=4
 IBV=10.000E-6
 TT=4.3200E-6

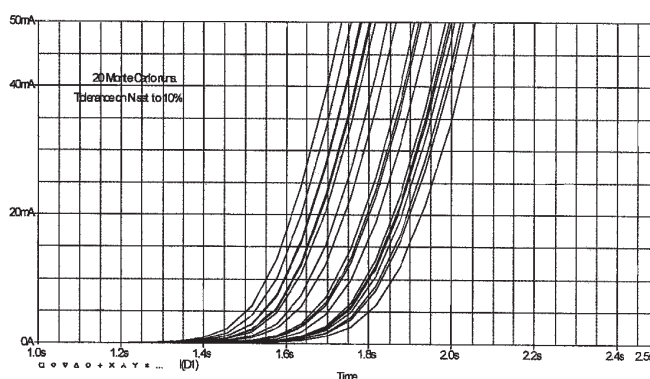

Figure 3

Assigning a 10% tolerance to N causes the forward characteristics of each LED in the circuit to vary randomly during Monte Carlo analysis.

pulse, and the simulations determine the peak current through D₁ for 0, 10, and 100Ω resistance values. The model statement assigned a 10% tolerance to N, and the example executes 50 Monte Carlo

runs. The results for R=0 reveal a large standard deviation of 10 mA. The results for R=10 reveals a smaller standard deviation of about 5 mA (Figure 4b). The results for R=100 reveals a small stan-

dard deviation of only 1 mA.

Is this the best Design Idea in this issue? Vote at www.ednmag.com/ednmag/vote.asp.

Figure 4

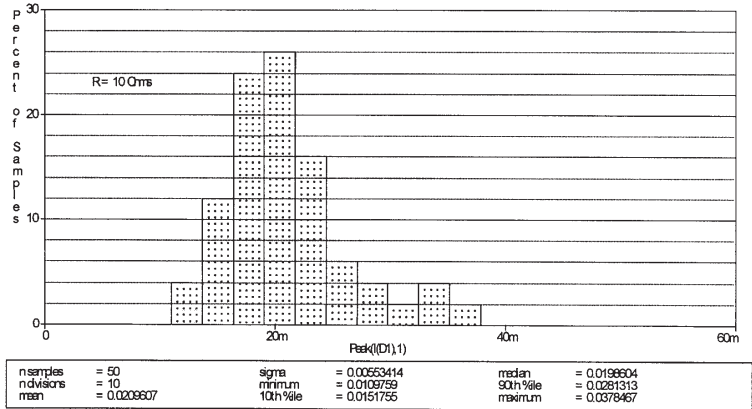
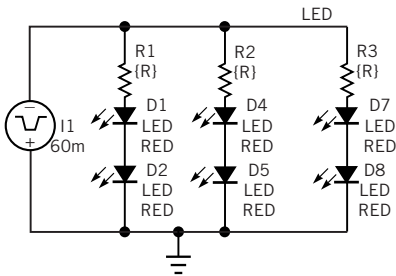

To analyze a simple circuit (a), simulations determine the peak current through D1 for three resistance values. The results for R=10Ω reveal a standard deviation of approximately 5 mA (b).

Programmable-gain amplifier is low-cost

J Jayapandian, Indira Gandhi Centre for Atomic Research, Kalpakkam, India

NUMEROUS programmable-gain amplifiers are available, but a simple solution provides the option of using 256 gain steps with an 8-bit DAC and higher steps with higher bit DACs (Figure 1). According to the inverting-amplifier configuration of an op amp, the output voltage is $V_{OUT} = V_{IN} (R_F / R_{IN})$, where R_F is the feedback resistance, R_{IN} is the input resistance, and V_{IN} is the input voltage of the amplifier circuit. Generally, by changing the feedback resistance, you can get the desired gain.

In this design, the 8-bit DAC in the input stage acts as a programmable attenuator for the input signal and permits a maximum full-scale I_{OUT1} of 1 mA. The value of I_{OUT1} is proportional to the in-

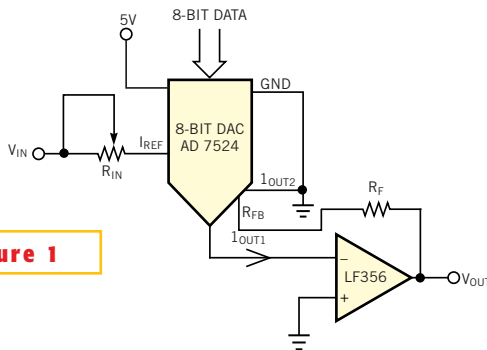

Figure 1

A DAC in series with an op amp attenuates the input signal to achieve the variable-gain factor.

put-voltage signal. The shunt feedback resistance, R_F , converts I_{OUT1} to a voltage. Thus, the input signal, V_{IN} , acts as a reference input to the DAC. Instead of increasing the value of the feedback resistor for higher gain, this circuit uses the

DAC in series with the op amp to attenuate the input signal and achieve the desired variable-gain factor. You calculate the current output, I_{OUT1} , from the DAC as follows, where D_0 through D_7 are the digital inputs to the DAC:

$$I_{OUT1} = \frac{V_{IN}}{R_{IN}} \left(\frac{D_0}{2} + \frac{D_1}{4} + \frac{D_2}{8} + \frac{D_3}{16} + \frac{D_4}{32} + \frac{D_5}{64} + \frac{D_6}{128} + \frac{D_7}{256} \right)$$

For example, if all of the bits are ones, the 8-bit digital image is FF, and the corresponding amplifier full-scale output is:

$$V_{OUT} = I_{OUT1} \cdot R_F = \frac{V_{IN} (255)}{R_{IN} (256)} \cdot R_F$$

In an actual application, keep the value of R_F fixed for the maximum gain. By varying the digital image pattern from 00 to FF, you can get the variable amplifier gain according to your requirements.

Is this the best Design Idea in this issue? Vote at www.ednmag.com/ednmag/vote.asp.

PC hardware monitor reports the weather

Sean Gilmour, Analog Devices, Limerick Ireland

YOU USUALLY USE PC hardware monitors to keep a close eye on power-supply voltage levels, the speed of system cooling fans, and even the temperature of the CPU. Until fairly recently, this level of system monitoring was reserved for high-end servers running mission-critical applications. However, now that low-cost hardware monitoring ASICs are available, advanced hardware monitoring has become a standard feature in most new PCs. And hardware monitors are now finding their way into diverse applications, such as weather stations (Figure 1).

IC₁ has two external temperature-measurement channels. One channel connects to a resistive humidity sensor, and a second channel uses a 2N3906 transistor to sense the outdoor temperature. The internal temperature sensor measures the indoor temperature. One of the tachometer inputs connects to the output of a wind-speed meter. For each

of the measurement inputs, you can set limits that warn the user of changing weather conditions. IC₁ uses a switching-current-measurement scheme, so you can mount the sensors hundreds of feet from the IC and still maintain a high SNR.

IC₁ connects to a parallel printer port using a 74HC07 open-drain noninverting buffer. Pin 2 of the parallel port is the serial clock. Pin 3 writes configuration data into IC₁, and Pin 13 reads data from IC₁.

The necessary software is simple, and the parallel-printer port is easily accessible using freeware drivers and DLLs that you can find on the Internet. You can bit-bang the SCL and SDATA lines using a programming language such as Visual Basic or Visual C++.

The temperature-measurement channels use a thermal diode, such as that on Intel's Pentium processors (PII+), or a discrete npn or pnp transistor. These

channels use a two-wire scheme that supplies switching current levels to the transistor. IC₁ measures the difference in V_{BE} between these two currents and calculates the temperature according to the following well-known relationship:

$$\Delta V_{BE} = KT/q \times \ln(N),$$

where K is Boltzmann's constant, q is the charge of an electron, T is the absolute temperature in Kelvin, and N is the ratio of the two currents.

You can also use the CPU temperature-monitoring channels to measure changes in resistance, making them useful for most resistive sensors, including photo diodes, photo resistors, gas sensors, and resistive-humidity sensors.

Is this the best Design Idea in this issue? Vote at www.ednmag.com/ednmag/vote.asp.

Figure 1

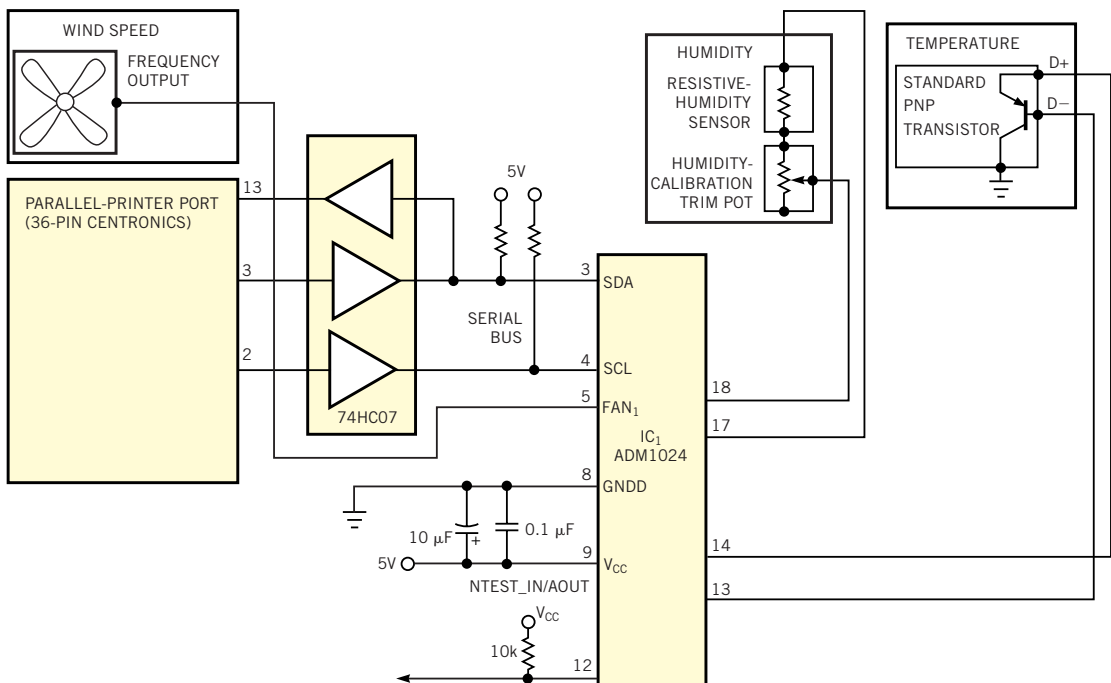

A PC hardware-monitor IC can also monitor weather-station characteristics.