

Demystifying Auto-Zero Amplifiers—Part 1

They essentially eliminate offset, drift, and 1/f noise. How do they work? Is there a downside?

by Eric Nolan

INTRODUCTION

Whenever the subject of auto-zero or chopper-stabilized amplifiers comes up, the inevitable first question is “How do they really work?” Beyond curiosity about the devices’ inner workings, the real question in most engineers’ minds is, perhaps, “The dc precision looks incredible, but what kind of weird behavior am I going to have to live with if I use one of these in my circuit; and how can I design around the problems?” Part 1 of this article will attempt to answer both questions. In Part 2, to appear in the next issue, some very popular and timely applications will be mentioned to illustrate the significant advantages, as well as some of the drawbacks, of these parts.

CHOPPER AMPLIFIERS—HOW THEY WORK

The first chopper amplifiers were invented more than 50 years ago to combat the drift of dc amplifiers by converting the dc voltage to an ac signal. Initial implementations used switched ac coupling of the input signal and synchronous demodulation of the ac signal to re-establish the dc signal at the output. These amplifiers had limited bandwidth and required post-filtering to remove the large ripple voltages generated by the chopping action.

Chopper-stabilized amplifiers solved the bandwidth limitations by using the chopper amplifier to stabilize a conventional wide-band amplifier that remained in the signal path¹. Early chopper-stabilized designs were only capable of inverting operation, since the stabilizing amplifier’s output was connected directly to the non-inverting input of the wide-band differential amplifier. Modern IC “chopper” amplifiers actually employ an auto-zero approach using a two-or-more-stage composite amplifier structure similar to the chopper-stabilized scheme. The difference is that the stabilizing amplifier signals are connected to the wide-band or main amplifier through an additional “nulling” input terminal, rather than one of the differential inputs. Higher-frequency signals bypass the nulling stage by direct connection to the main amplifier or through the use of feed-forward techniques, maintaining a stable zero in wide-bandwidth operation.

This technique thus combines dc stability and good frequency response with the accessibility of both inverting and noninverting configurations. However, it may produce interfering signals consisting of high levels of digital switching “noise” that limit the usefulness of the wider available bandwidth. It also causes intermodulation distortion (IMD), which looks like aliasing between the clock signal and the input signal, producing error signals at the sum and difference frequencies. More about that later.

Auto-Zero Amplifier Principle

Auto-zero amplifiers typically operate in two phases per clock cycle, illustrated in Figures 1a and 1b. The simplified circuit shows a nulling amplifier (A_A), a main (wide-band) amplifier (A_B), storage capacitors (C_{M1} and C_{M2}), and switches for the inputs and storage capacitors. The combined amplifier is shown in a typical op-amp gain configuration.

In *Phase A*, the auto-zero phase (Figure 1a), the input signal is applied to the main amplifier (A_B) alone; the main amplifier’s nulling input is supplied by the voltage stored on capacitor C_{M2} ; and the nulling amplifier (A_A) auto-zeros itself, applying its nulling voltage to C_{M1} . In *Phase B*, with its nulling voltage furnished by C_{M1} , the nulling amplifier amplifies the input difference voltage applied to the main amplifier and applies the amplified voltage to the nulling input of the main amplifier and C_{M2} .

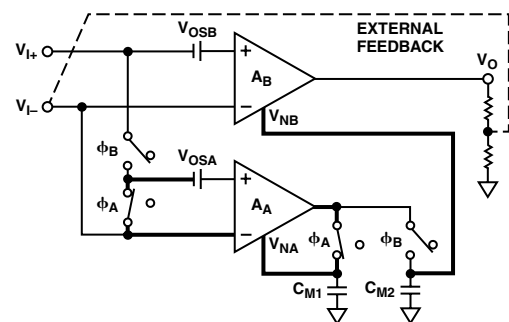

a. Auto-Zero Phase A: null amplifier nulls its own offset.

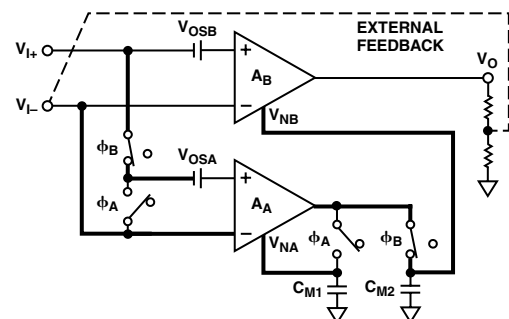

b. Output Phase B: null amplifier nulls the main amplifier offset.

Figure 1. Switch settings in the auto-zero amplifier.

Both amplifiers use the trimmable op-amp model (Figure 2), with differential inputs and an offset-trim input.

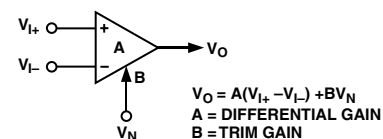

Figure 2. Trimmable op-amp model.

In the nulling phase (Phase A—Figure 1a), the inputs of the nulling amp are shorted together and to the inverting input terminal (common-mode input voltage). The nulling amplifier nulls its own inherent offset voltage by feeding back to its nulling terminal whatever opposing voltage is required to make the product of that

¹Edwin Goldberg and Jules Lehmann, U. S. Patent 2,684,999: Stabilized dc amplifier.

voltage and the incremental gain of the nulling input approximately equal to A_A 's input offset (V_{OS}). The nulling voltage is also impressed on C_{M1} . Meanwhile, the main amplifier is behaving like a normal op amp. Its nulling voltage is being furnished by the voltage stored on C_{M2} .

During the output phase (Phase B—Figure 1b) the inputs of the nulling amplifier are connected to the input terminals of the main amplifier. C_{M1} is now continuing to furnish the nulling amplifier's required offset correction voltage. The difference input signal is amplified by the nulling amplifier and is further amplified by the incremental gain of the main amplifier's nulling input circuitry. It is also directly amplified by the gain of the main amplifier itself (A_B). The op amp feedback will cause the output voltage of the nulling amplifier to be whatever voltage is necessary at the main amplifier's nulling input to bring the main amplifier's input difference voltage to near-null. Amplifier A_A 's output is also impressed on storage capacitor C_{M2} , which will hold that required voltage during the next Phase A.

The total open-loop amplifier dc gain is approximately equal to the product of the nulling amplifier gain and the wide-band amplifier nulling terminal gain. The total effective offset voltage is approximately equal to the sum of the main-amplifier and nulling-amplifier offset voltages, divided by the gain at the main amplifier nulling terminal. Very high gain at this terminal results in very low effective offset voltage for the whole amplifier.

As the cycle returns to the nulling phase, the stored voltage on C_{M2} continues to effectively correct the dc offset of the main amplifier. The cycle from nulling to output phase is repeated continuously at a rate set by the internal clock and logic circuits. (For detailed information on the auto-zero amplifier theory of operation see the data sheets for the AD8551/AD8552/AD8554 or AD857x amplifiers).

Auto-Zero Amplifier Characteristics

Now that we've seen how the amplifier works, let's examine its behavior in relation to that of a "normal" amplifier. First, please note that a commonly heard myth about auto-zero amplifiers is untrue: the gain-bandwidth product of the overall amplifier is *not* related to the chopping clock frequency. While chopping clock frequencies are typically between a few hundred Hz and several kHz, the gain bandwidth product and unity-gain bandwidth of many recent auto-zero amplifiers is 1 MHz–3 MHz—and can be even higher.

A number of highly desirable characteristics can be easily inferred from the operating description: dc open-loop voltage gain, the product of the gains of two amplifiers, is very large, typically more than 10 million, or 140 dB. The offset voltage is very low due to the effect of the large nulling-terminal gain on the raw amplifier offsets. Typical offset voltages for auto-zero amplifiers are in the range of one microvolt. The low effective offset voltage also impacts parameters related to dc changes in offset voltage—dc CMR and PSR, which typically exceed 140 dB. Since the offset voltage is continuously "corrected," the shift in offset over time is vanishingly small, only 40 nV–50 nV per month. The same is true of temperature effects. The offset temperature coefficient of a well-designed amplifier of this type is only a few nanovolts per °C!

A less obvious consequence for the amplifier's operation is the low-frequency "1/f noise" characteristic. In "normal" amplifiers, the input voltage noise spectral density increases exponentially inversely with frequency below a "corner" frequency, which may be anywhere from a few Hz to several hundred Hz. This low-frequency noise looks like an offset error to the auto-correction circuitry of the chopper-stabilized or auto-zero amplifier. The auto-correction action becomes more efficient as the frequency approaches dc. As a result of the high-speed chopper action in an auto-zero amplifier, the low-frequency noise is relatively flat down to dc (no 1/f noise!). This lack of 1/f noise can be a big advantage in low-frequency applications where long sampling intervals are common.

Because these devices have MOS inputs, bias currents, as well as current noise, are very low. However, for the same reason, wide-band voltage noise performance is usually modest. The MOS inputs tend to be noisy, especially when compared to precision bipolar-processed amplifiers, which use large input devices to improve matching and often have generous input-stage tail currents. Analog Devices AD855x amplifiers have about one-half the noise of most competitive parts. There is room for improvement, however, and several manufacturers (including ADI) have announced plans for lower-noise auto-zero amplifiers in the future.

Charge injection [capacitive coupling of switch-drive voltage into the capacitors] occurs as the chopping switches open and close. This, and other switching effects, generates both voltage and current "noise" transients at the chopping clock frequency and its harmonics. These noise artifacts are large compared to the wide-band noise floor of the amplifier; they can be a significant error source if they fall within the frequency band of interest for the signal path. Even worse, this switching causes intermodulation distortion of the output signal, generating additional error signals at sum and difference frequencies. If you are familiar with sampled-data systems, this will look much like aliasing between the input signal and the clock signal with its harmonics. In reality, small differences between the gain-bandwidth of the amplifier in the nulling phase and that in the output phase cause the closed-loop gain to alternate between slightly different values at the clock frequency. The magnitude of the IMD is dependent on the internal matching and does not relate to the magnitude of the clock "noise." The IMD and harmonic distortion products typically add up to about –100 dB to –130 dB plus the closed-loop gain (in dB), in relation to the input signal. You will see below that simple circuit techniques can limit the effects of both IMD and clock noise when they are out of band.

Some recent auto-zero amplifier designs with novel clocking schemes, including the AD857x family from Analog Devices, have managed to tame this behavior to a large degree. The devices in this family avoid the problems caused by a single clocking frequency by employing a (patented) spread-spectrum clocking technique, resulting in essentially pseudorandom chopper-related noise. Since there is no longer a peak at a single frequency in either the intrinsic switching noise or "aliased" signals, these devices can be used at signal bandwidths beyond the nominal chopping frequency without a large error signal showing up in-band. Such amplifiers are much more useful for signal bandwidths above a few kHz.

Some recent devices have used somewhat higher chopping frequency, which can also extend the useful bandwidth. However, this approach can degrade V_{OS} performance and increase the input bias current (see below regarding charge injection effects); the design trade-offs must be carefully weighed. Extreme care in both design and layout can help minimize the switching transients.

As mentioned above, virtually all monolithic auto-zero amplifiers have MOS input stages, tending to result in quite low input bias currents. This is a very desirable feature if large source impedances are present. However, charge injection produces some unexpected effects on the input bias-current behavior.

At low temperatures, gate leakage and input-protection-diode leakage are very low, so the dominant input bias-current source is charge injection on the input MOSFETs and switch transistors. The charge injection is in opposing directions on the inverting and noninverting inputs, so the input bias currents have opposing polarities. As a result, the *input offset current is larger than the input bias current*. Fortunately, the bias current due to charge injection is quite small, in the range of 10 pA–20 pA, and it is relatively insensitive to common-mode voltage.

As device temperature rises above 40°C to 50°C, the reverse leakage current of the input protection diodes becomes dominant; and input bias current rises rapidly with temperature (leakage currents approximately double per 10°C increase). The leakage currents have the same polarity at each input, so at these elevated temperatures the input offset current is smaller than the input bias current. Input bias current in this temperature range is strongly dependent on input common-mode voltage, because the reverse bias voltage on the protection diodes changes with common-mode voltage. In circuits with protection diodes connected to both supply

rails the bias current polarity changes as the common-mode voltage swings over the supply-voltage range.

Due to the presence of storage capacitors, many auto-zero amplifiers require a long time to recover from output saturation (commonly referred to as overload recovery). This is especially true for circuits using external capacitors. Newer designs using internal capacitors recover faster, but still take milliseconds to recover. The AD855x and AD857x families recover even faster—at about the same rate as “normal” amplifiers—taking less than 100 μ s. This comparison also holds true for turn-on settling time.

Finally, as a consequence of the complex additional circuitry required for the auto-correction function, auto-zero amplifiers require more quiescent current for the same level of ac performance (bandwidth, slew rate, voltage noise and settling time) than do comparable nonchopped amplifiers. Even the lowest power auto-zero amplifiers require hundreds of microamperes of quiescent current; and they have a very modest 200-kHz bandwidth with broadband noise nearly 150 nV/\sqrt{Hz} at 1 kHz. In contrast, some standard CMOS and bipolar amplifiers offer about the same bandwidth, with lower noise, on less than 10 μ A of quiescent current.

APPLICATIONS

Notwithstanding all of the differences noted above, applying auto-zero amplifiers really isn't much different from applying any operational amplifier. In the next issue, Part 2 of this article will discuss application considerations and provide examples of applications in current shunts, pressure sensors and other strain bridges, infrared (thermopile) sensors, and precision voltage references.