

# MHz Filters

## Introduction

Today, most FM radio designs use 10.7MHz IF filters. The characteristics of these filters help determine the performance characteristics of the radio it is used in. Besides providing low cost filtering, ceramic 10.7MHz IF filters provide high selectivity, excellent temperature and environmental characteristics, optimal GDT performance, and a pass-band that is symmetrical around the center frequency. Such filters can provide all this while being packaged in a very compact leaded or SMD package.

Murata also makes MHz filters for TV sound IF filtering. These filters operate similar to 10.7MHz filters, but cover the 3.58 to 7.0MHz range. This range covers the common Sound IF frequencies for NTSC and PAL based systems.

## How Does It Work

Ceramic 10.7 MHz IF filters do not use a ladder construction like the kHz filters. The MHz filters are monolithic (one or more elements on a single substrate) in construction, similar to ceramic resonators.

These filters utilize the trapped energy of the thickness longitudinal vibration mode in a single ceramic substrate to achieve the filtering effect, unlike the kHz filters that require a number of elements to achieve the filtering effect.

You may ask why Murata does not make the kHz filter like the MHz filter or the MHz like the kHz. The answer to this is that the frequency of operation determines which vibration mode may be used to achieve the filtering effect. The area vibration mode used by the kHz filters does not work in the MHz range and the thickness longitudinal vibration mode used by the MHz filters does not work in the kHz range.

The thickness longitudinal vibration mode is used in ceramic resonators as well as MHz filters. We will start the explanation of how these filters work by explaining how a resonator works and then progress to the more complex design of the filter.

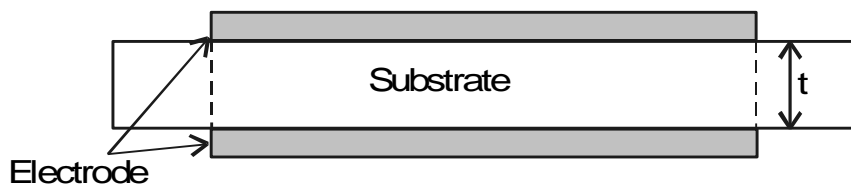

**Figure 41: Basic Construction of Thickness Vibration Mode Resonator**

Figure 41 shows the basic construction of a thickness expansion vibration mode resonator. A thin ceramic substrate has metal electrodes on both the top and bottom, directly over each other. Vibration of the resonator occurs only in the ceramic between the electrodes. The thickness of the ceramic substrate, shown as  $t$  in Figure 41, determines the resonant frequency of the resonator. While this design results in a very good ceramic resonator, other modifications must be made in order to make it a good filter.

Here, we come upon the idea of multi-coupling mode. In multi-coupling mode, the top electrode is divided into two separate electrodes. This new electrode allows different frequency resonances to become trapped between the electrodes (two vibration modes instead of one). The phase relationship between these two vibration modes is different as well.

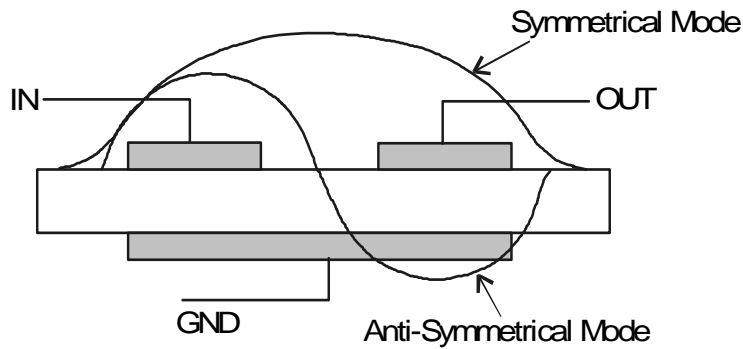

**Figure 42: MHz Filter Vibration Mode**

Figure 42 shows the two vibration modes resulting from the splitting of the electrode, the symmetrical and anti-symmetrical vibration modes. Since there are now two vibration modes, it is the same as having two elements in the filter.

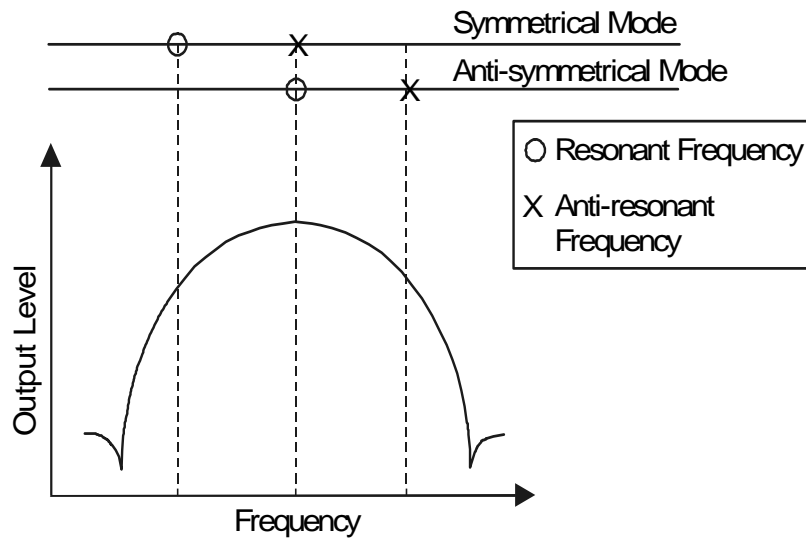
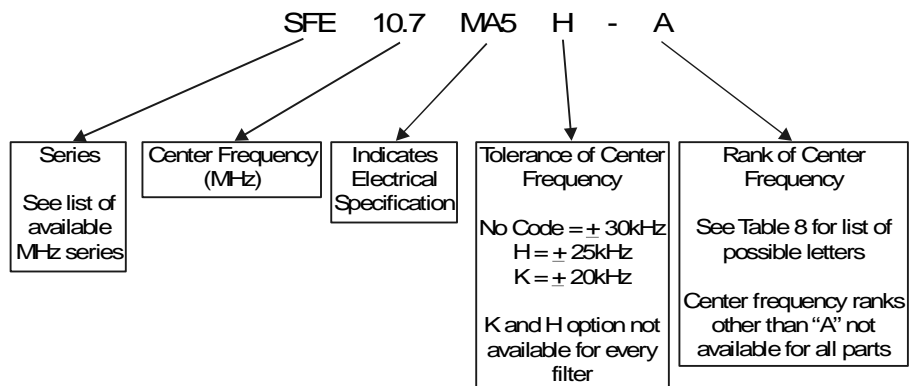

**Figure 43: How the Filter Achieves Bandpass Filter Effect**

Figure 43 shows how the symmetrical and anti-symmetrical modes are utilized to create the filter response. Each mode has its own resonant and anti-resonant frequency, like two separate elements. By cascading two of these split electrode patterns we produce Murata's SFE10.7 filters. Murata's SFT10.7 filters use three of these split electrode patterns on a single substrate to make an even higher selectivity filter.

## Parts

The following tables show the MHz part numbering system and the filters offered by Murata. Figure 44 below describes the basic 10.7 MHz part number structure.



**Figure 44: MHz Part Numbering System**

Table 8 indicates the possible center frequency rank for the 10.7MHz filters. While all ranks are possible, all ranks have not been design up each 10.7MHz part number. Please consult with Murata for rank availability for specific 10.7MHz part number.

Code	30kHz Step Tolerance Code Equal To "No Code"	25 kHz Step Tolerance Code Equal To "H"	Color Code
D	10.64MHz±30kHz	10.64MHz±25kHz	Black
B	10.67MHz±30kHz	10.67MHz±25kHz	Blue
A	10.70MHz±30kHz	10.70MHz±25kHz	Red
C	10.73MHz±30kHz	10.73MHz±25kHz	Orange
E	10.76MHz±30kHz	10.76MHz±25kHz	White
Z	Combination Of: A,B,C,D,E		
M	Combination Of: A,B,C		

**Table 8. Rank of Center Frequency**

Table 9 describes each commonly available 10.7MHz and Sound IF (SFSH) filter series. Some older series are listed for reference only so any part with an asterisk (\*) by it is no longer available for new designs.

MHz Filter Series Type	Description	GDT Type	SMD
SFE A10	Low loss and high selectivity	N	N
SFE B10	High attenuation	N	N
SFE C10	Thin and low profile. Same performance.	N	N
SFE MX	Controlled G.D.T filter	Y	N
SFE MA8	Controlled G.D.T filter	Y	N
SFE ML	Controlled G.D.T filter	Y	N
SFE MA19	Wide bandwidth filter.	N	N
SFE MTE	Narrow bandwidth	N	N
SFE MVE	Narrow bandwidth	N	N
SFE MFP	Narrow bandwidth	N	N

**Table 9. MHz Filter Series Description**

SFT	Single substrate 3 section filter. High selectivity and spurious suppression.	N	N
SFECV	Surface mount IF filter	N	Y
SFECS	Miniature version of SFECV	N	Y
CFEC*	Surface mount IF filter	N	Y
KMFC545	Super wide bandwidth filter	N	N
CFECV	GDT controlled version of SFECV	Y	Y
CFECS	Miniature version of CFECV	Y	Y
SFSH*	TV IF filter, 3.58 – 6.5MHz	N	N
SFSRA	TV IF filter, 3.58 – 6.5MHz	N	N
SFSCC	Surface Mount TV IF filter, 3.58 – 6.5MHz	N	Y

**Table 9. MHz Filter Series Description**

Table 10 provides general electrical specification for common 10.7MHz and Sound IF (SFSH) filters. *Please note that values in parentheses are typical values.*

Part Number	Nominal Center Frequency (MHz)	3dB Bandwidth (kHz) min.	20 dB Bandwidth (kHz) max.	Insertion Loss (dB)	Input/output Impedance	Ripple (dB) max.	Spurious (9-12MHz) (dB) min.	G.D.T. Bandwidth (kHz) min.
<b>SFE Series</b>								
SFE10.7MA5-A	10.7	280±50	650 (520)	6 (4)	330	1	30 (43)	-----
SFE10.7MS2-A	10.7	230±50	570 (420)	6 (4)	330	1	40 (45)	-----
SFE10.7MS3-A	10.7	180±40	520 (380)	7 (4.5)	330	1	40 (45)	-----
SFE10.7MA5A10-A	10.7	280±50	590 (480)	2.5 ± 2.0	330	1	30 (42)	-----
SFE10.7MS2A10-A	10.7	230±40	520 (410)	3.0 ± 2.0	330	1	35 (42)	-----
SFE10.7MS3A10-A	10.7	180±40	470 (370)	3.5 ± 1.5	330	1	35 (42)	-----
SFE10.7MJA10-A	10.7	150±40	360 (300)	4.5 ± 2.0	330	1	35 (42)	-----
SFE10.7MA5B10-A	10.7	280±50	650	3.0 ± 2.0	330	1	45	-----
SFE10.7MS2B10-A	10.7	230±50	570	3.0 ± 2.0	330	1	45	-----
SFE10.7MS3B10-A	10.7	180±40	520	5.0 ± 2.0	330	1	45	-----
SFE10.7MA5C10-A	10.7	280±50	650 (540)	3.0 ± 2.0	330	1	30 (47)	-----
SFE10.7MS2C10-A	10.7	230±50	570 (470)	3.0 ± 2.0	330	1	40 (49)	-----
SFE10.7MS3C10-A	10.7	180±40	470 (360)	3.5 ± 2.0	330	1	35 (47)	-----
SFE10.7MJC10-A	10.7	150±40	360 (300)	4.5 ± 2.0	330	1	35 (42)	-----
SFE10.7MHC10-A	10.7	110±30	350 (260)	7.0 ± 2.0	330	1	30 (38)	-----
SFE10.7MX-A	10.7	250±40	670 (620)	12 (10)	330	0 max.	25 (33)	0.2µS f <sub>o</sub> ± 110kHz
SFE10.7MX2-A	10.7	220±40	610 (560)	12.5 (10.5)	330	0 max.	30 (37)	0.15µS f <sub>o</sub> ± 80kHz
SFE10.7MZ1-A	10.7	180±30	530 (460)	14 (12.3)	330	0 max.	33 (38)	0.15µS f <sub>o</sub> ± 60kHz
SFE10.7MZ2-A	10.7	150±30	500 (420)	14 (12.6)	330	0 max.	35 (41)	0.15µS f <sub>o</sub> ± 50kHz
SFE10.7MA8-A	10.7	280±50	650 (520)	6 (4)	330	0.5 max.	30 (43)	0.5µS f <sub>o</sub> ± 80 (100)
SFE10.7MS2G-A	10.7	230±50	600 (420)	7 (4.5)	330	0 max.	40 (45)	0.5µS f <sub>o</sub> ± 60 (75)
SFE10.7MS3G-A	10.7	180±40	520 (380)	7 (5)	330	0 max.	40 (45)	0.5µS f <sub>o</sub> ± 45 (60)
SFE10.7ML-A	10.7	280±50	700 (610)	9 (7)	330	0 max.	25 (33)	0.25µS f <sub>o</sub> ± 70 (105)
SFE10.7MP3-A	10.7	250±50	650 (550)	10 (8)	330	1.0 max.	30 (35)	0.25µS f <sub>o</sub> ± 65 (90)
SFE10.7MM-A	10.7	230±50	600 (510)	11 (9)	330	0 max.	30 (38)	0.25µS f <sub>o</sub> ± 60 (85)
SFE10.7MA19	10.7	350 (450)	950 (750)	3 ± 2	330	3	20 (30)	-----
SFE10.7MA20-A	10.7	330 ± 50	680 (615)	4 ± 2	330	1	30 (40)	-----
SFE10.7MA21	10.7	400 (500)	950 (750)	3 ± 2	330	3	20 (30)	-----
SFE10.7MHY-A	10.7	110±30	350 (260)	7 ± 2	330	1	30 (38)	-----
SFE10.7MTE	10.7	±25 (80)	200 (160)	6.5 ± 2.5	330	1	30 (55)	-----
SFE10.7MVE	10.7	±13 (53)	135 (109)	6.0 ± 2.0	330	1	30 (50)	-----
SFE10.7MFP	10.7	±20 (38)	95 (78)	6.0 (3.4)	330	1	24 (28)	-----
SFE10.7MFP1	10.7	F <sub>n</sub> ±5 min. F <sub>n</sub> ±35 max.	-----	6	600	-----	-----	-----

**Table 10. MHz Filters**

<b>SFT Series</b>			40 dB Bandwidth (kHz) max.			Ripple within 3dB BW (dB)		
SFT10.7MA5	10.7	280 ± 50	700 (630)	6 ± 2	330	0.5 max.	50 (60)	-----
SFT10.7MS2	10.7	230 ± 40	650 (580)	6 ± 2	330	0.5 max.	50 (60)	-----
SFT10.7MS3	10.7	180 ± 40	550 (500)	8 ± 2	330	0.5 max.	50 (60)	-----
<b>SFECV Series</b>								
SFECV10.7MA21S-A-TC	10.7	400 ± 50	-----	3.0 ± 2	470	3.0 max.	20	-----
SFECV10.7MA19S-A-TC	10.7	350 ± 50	-----	3.0 ± 2.0	470	3.0 max.	20	-----
SFECV10.7MA2S-A-TC	10.7	330 ± 50	-----	4 ± 2	330	-----	30	-----
SFECV10.7MA5S-A-TC	10.7	280±50	-----	6	330	-----	30	-----
SFECV10.7MS2S-A-TC	10.7	230±50	-----	6	330	-----	30	-----
SFECV10.7MS3S-A-TC	10.7	180±40	-----	7	330	-----	30	-----
SFECV10.7MHS-A-TC	10.7	150±40	-----	5.5 ± 2.0	330	-----	30	-----
SFECV10.7MJS-A-TC	10.7	110±30	-----	6.0 ± 2.0	330	-----	35	-----
<b>SFECS Series</b>								
SFECS10.7MA5-A-TC	10.7	280±50	590	3.0 ± 2	330	1.0 max.	30	-----
SFECS10.7MS2-A-TC	10.7	230±50	510	3.5 ± 2	330	1.0 max.	30	-----
SFECS10.7MS3-A-TC	10.7	180±40	470	4.5 ± 2	330	1.0 max.	30	-----
<b>CFEC Series*</b>								
CFEC10.8MK1-TC	10.8	±110 to ±115	±310	6	330	(fn ± 100kHz) 0.5	-----	(fn ± 100kHz) 1.5
CFEC10.8MG1-TC	10.8	±135 to ±180	±350	6	330	(fn ± 100kHz) 0.5	-----	(fn ± 100kHz) 1.2
CFEC10.8ME11-TC	10.8	±150	±420	5	330	(fn ± 110kHz) 1	25	(fn ± 110kHz) 1.5
CFEC10.8MD11-TC	10.8	±170	±450	5	600	(fn ± 170kHz) 1	25	(fn ± 170kHz) 2.0
<b>CFECS Series</b>								
CFECS10.75ME11	10.75	±110	±310	6	330	0.5	-----	1.5
CFECS10.75MK1	10.75	±150	±420	5	330	1	25	1.5
CFECS14.6ME21	14.6	±150	±500	6	330	1	-----	0.8
CFECS14.6ME27	14.6	±90	-----	6	330	2	-----	1
<b>CFECV Series</b>								

Table 10. MHz Filters

CFECV13.0ME21	13.0	±90	-----	6	330	1	-----	1.5
CFECV14.6ME21	14.6	±150	±500	6	330	1	-----	0.8
<b>SFSH Series</b>								
SFSH4.5MCB	4.5	±60 (110)	600 (470)	6 (3.2)	1000	-----	30 (0 - 4.5MHz)	-----
SFSH5.5MCB	5.5	±60 (115)	600 (500)	6 (3.6)	600	-----	30 (0 - 5.5MHz)	-----
SFSH6.0MCB	6	±60 (115)	600 (500)	6 (4.0)	470	-----	30 (0 - 6.0MHz)	-----
SFSH6.5MCB	6.5	±70 (115)	650 (530)	6 (3.6)	470	-----	30 (0 - 6.5MHz)	-----
SFSH4.5MDB	4.5	±70 (130)	750 (520)	6 (3.0)	1000	-----	30 (0 - 4.5MHz)	-----
SFSH5.5MDB	5.5	±80 (150)	750 (640)	6 (3.0)	600	-----	30 (0 - 5.5MHz)	-----
SFSH6.0MDB	6	±80 (155)	750 (640)	6 (3.8)	470	-----	30 (0 - 6.0MHz)	-----
SFSH6.5MDB	6.5	±80 (150)	800 (640)	6 (3.4)	470	-----	30 (0 - 6.5MHz)	-----
SFSH4.5MEB2	4.5	±125 (180)	800 (740)	6 (3.0)	1000	-----	25 (0 - 4.5MHz)	-----
<b>SFSRA Series</b>								
SFSRA4M50EF00-B0	4.5	±125	850	6.0 max.	1000	-----	25 (0 - 4.5MHz)	-----
SFSRA4M50DF00-B0	4.5	±70	750	6.0 max.	1000	-----	30 (0 - 4.5MHz)	-----
SFSRA5M50DF00-B0	5.5	±80	750	6.0 max.	600	-----	30 (0 - 5.5MHz)	-----
SFSRA6M00DF00-B0	6.0	±80	750	6.0 max.	470	-----	30 (0 - 6.0MHz)	-----
SFSRA6M50DF00-B0	6.5	±80	800	6.0 max.	470	-----	30 (0 - 6.5MHz)	-----
SFSRA4M50CF00-B0	4.5	±60	600	6.0 max.	1000	-----	30 (0 - 4.5MHz)	-----
SFSRA5M50EF00-B0	5.5	±60	600	6.0 max.	600	-----	30 (0 - 5.5MHz)	-----
SFSRA6M00CF00-B0	6.0	±60	600	6.0 max.	470	-----	30 (0 - 6.0MHz)	-----
SFSRA6M50CF00-B0	6.5	±80	650	6.0 max.	470	-----	30 (0 - 6.5MHz)	-----
SFSRA5M50BF00-B0	5.5	±50	400	8.0 max.	600	-----	30 (0 - 5.5MHz)	-----
SFSRA5M74BF00-B0	5.742	±50	400	8.0 max.	600	-----	30 (0 - 5.742MHz)	-----
<b>KMFC Series</b>								
KMFC545	10.7	± 325	1400	5	470	2.0	23 (8 - 13MHz)	-----

Table 10. MHz Filters





## Applications

One of the primary uses of band pass filters is in receivers. The simplest receiver is called a super heterodyne receiver (Figure 46). This receiver uses two band pass filters to select the desired signal. The first filter is a wide bandwidth filter that helps reduce noise and extraneous signals. The local oscillator then mixes down the signals and the second band pass filter selects the correct IF frequency. In the USA, the IF for AM radio is 455kHz and the IF for FM radio is 10.7MHz. The signal then goes to an amplifier and then to a discriminator that strips away the carrier signal.

The second type of receiver is the double super heterodyne receiver (Figure 47). This receiver uses three band pass filters and two local oscillators. The first filter helps reduce noise just as before. The first local oscillator mixes the signal down to the first IF. The second filter selects only this IF frequency to pass on to the rest of the circuit. The second oscillator mixes the signal down to the second IF which is 455kHz or 10.7MHz as before. The third filter selects only these second IF frequencies to pass to the detector. This receiver has better selectivity due to the increased filtering and the smaller jump when the frequencies are mixed down.

## TV Filter Application

Murata's SFSH series was originally designed for TV applicat-8.8( )12.8( )118 apfd5ud 1(w)8.8( )1es1(wu)-8.9( e n)-13.1(a)12.1(t)

nal, a picture signal, and a color or chroma signal (Figure 48).

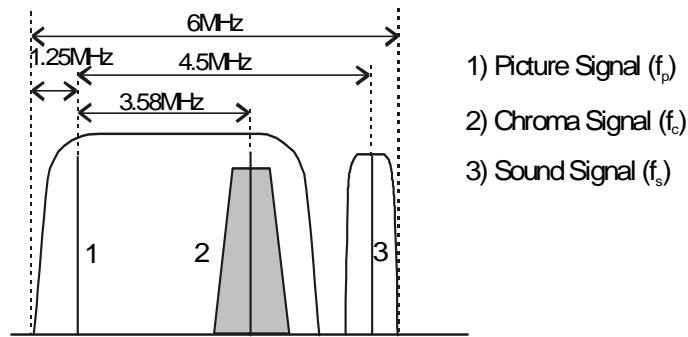

Figure 48: TV Channel Spectrum Description (NTSC-M)

A basic television receiver is shown in Figure 49.

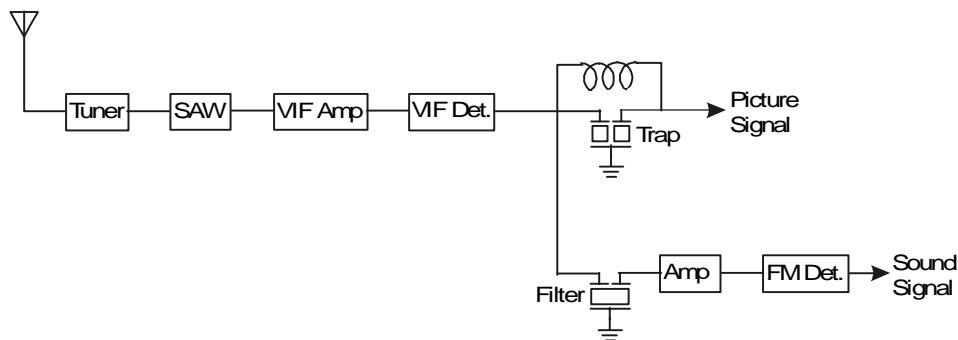

Figure 49: Inter-Carrier System

First a tuner shifts the desired channel to IF frequencies. A SAW filter selects only the IF frequencies and rejects all others. An amplifier increases signal strength and a detector demodulates the video signal. The signal is then split into two and a trap, or band reject filter, removes the sound IF before the signal is sent to the video signal processing circuit that drives the picture tube. On the other side, a filter, like Murata's SFSH series, removes the picture and chroma signals. A detector then demodulates the sound signal and it is sent to the speaker on the TV set. The trap is a band reject filter meaning that it will allow all frequencies to pass through it except a certain band. In this application, the trap allows all frequencies except the sound IF to pass. Murata also produces SAW filters and discriminators for sound signal detectors.