



INFRARED PARTS MANUAL

RE200B
FL65
S211FL

GLOLAB
CORPORATION

Thank you for buying our Pyroelectric Infrared components.

The goal of Glolab is to produce top quality electronic kits, products and components. All of our kits are designed by Glolab engineers and tested in our laboratory. Mechanical devices, prototypes and enclosures are fabricated in our precision machine shop.

Glolab Corporation has two locations in New York's Hudson Valley. Our electronics laboratory and kit packaging is located in Wappingers Falls and our machine shop is in Lagrangeville.

In addition to our kits, we supply some special and hard to find parts such as our Pyroelectric Infrared Sensor, Infrared Fresnel lens and machined enclosure for mounting our Fresnel lens. for those of you who want to design and build your own projects.

Technical help is available by email from lab@glolab.com.

Copyright © 1999
Glolab Corporation
134 Van Voorhis
Wappingers Falls, NY 12590

Infrared Radiation_____

Infrared radiation exists in the electromagnetic spectrum at a wavelength that is longer than visible light. Infrared radiation cannot be seen but it can be detected. Objects that generate heat also generate infrared radiation including animals and the human body whose radiation is strongest at a wavelength of 9.4 μ m.

Pyroelectric Sensors_____

The pyroelectric sensor is made of a crystalline material that generates a surface electric charge when exposed to heat in the form of infrared radiation. When the amount of radiation striking the crystal changes, the amount of charge also changes and can then be measured with a sensitive FET device built into the sensor. The sensor elements are sensitive to radiation over a wide range so a filter window is added to the TO5 package to limit incoming radiation to the 8 to 14 μ m range which is most sensitive to human body radiation.

Figure 1 shows how typically, the FET source terminal pin 2 connects through a pulldown resistor of about 100 K to ground and feeds into a two stage amplifier having signal conditioning circuits and a gain of 10,000 that produces a 0 to Vcc transition at its output. A well filtered power source of from 3 to 15 volts should be connected to the FET drain terminal pin 1. The amplifier is typically bandwidth limited to about 10Hz to reject high frequency noise and is followed by a window comparator that responds to both the positive and negative transitions of the sensor output signal.

The RE200B sensor has two sensing elements connected in a voltage bucking configuration. This arrangement cancels signals caused by vibration, temperature changes and sunlight. A body passing in front of the sensor will activate first one and then the other element as shown in figure 2 whereas other sources will affect both elements simultaneously and be cancelled. The radiation source must pass across the sensor in a horizontal direction when sensor pins 1 and 2 are on a horizontal plane so that the elements are sequentially exposed to the IR source.

Figure 3 shows the RE200B electrical specifications and layout in its TO5 package.

Figure 4 shows a typical application circuit that drives a relay. R16 adjusts the amount of time that RY1 remains closed after motion is detected.

TYPICAL CONFIGURATION

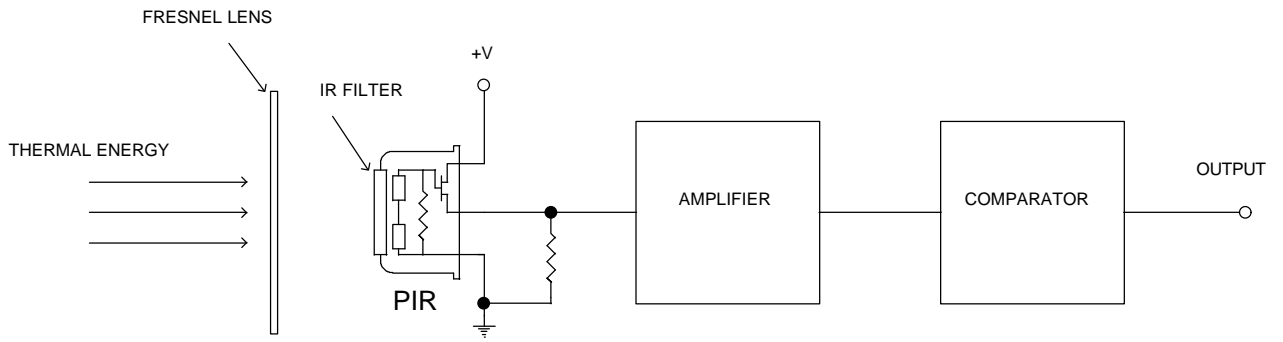

FIGURE 1

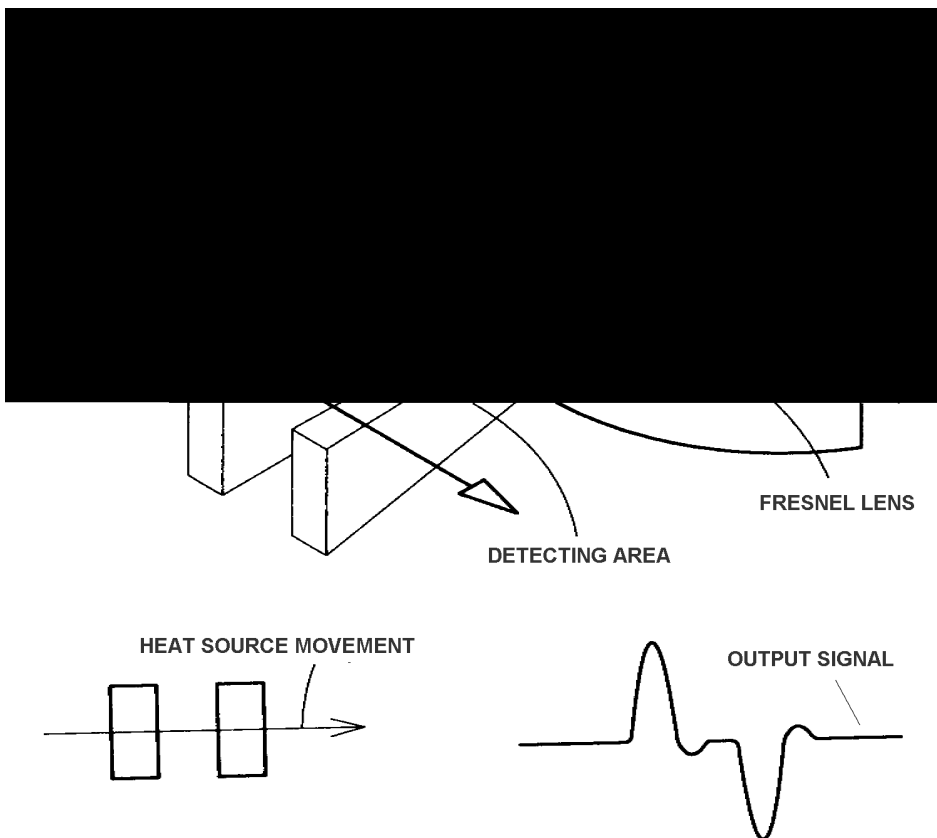
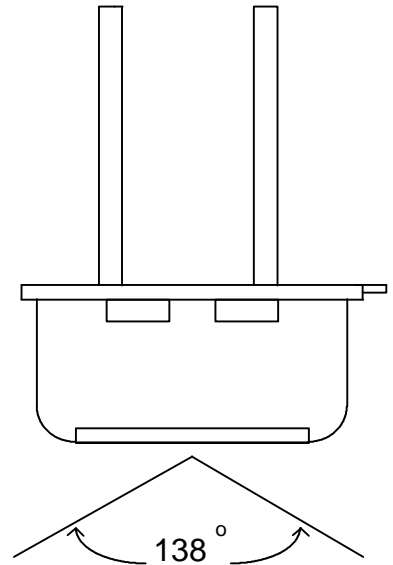
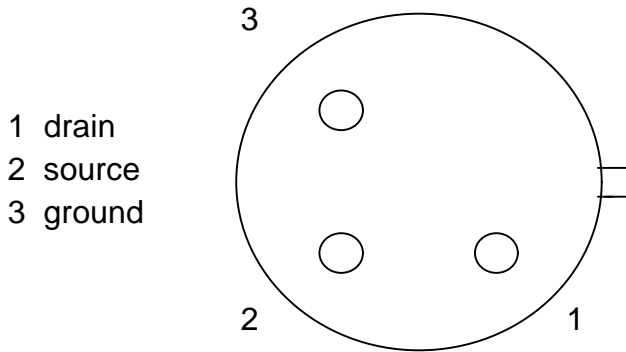

FIGURE 2

BOTTOM VIEW



RE200B

- SENSITIVE AREA 2 ELEMENTS
- SPECTRAL RESPONSE 5 - 14 μm
- OUTPUT VOLTAGE mv pp 20
- NOISE mv pp 0.4
- OFFSET VOLTAGE volts 0.1
- SUPPLY VOLTAGE volts 2.2 - 15
- OPERATING TEMP c 30 - 70

Test Conditions for output voltage:
Supply voltage = 5 volts
100K load resistor from pin 2 to 3
IR source = Hand moving 6" from sensor

TOP VIEW

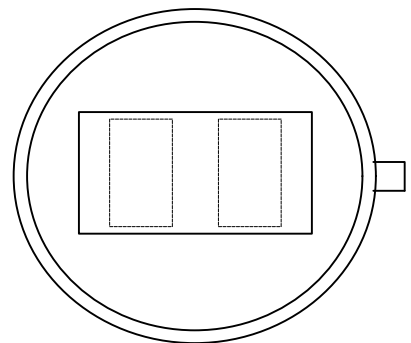
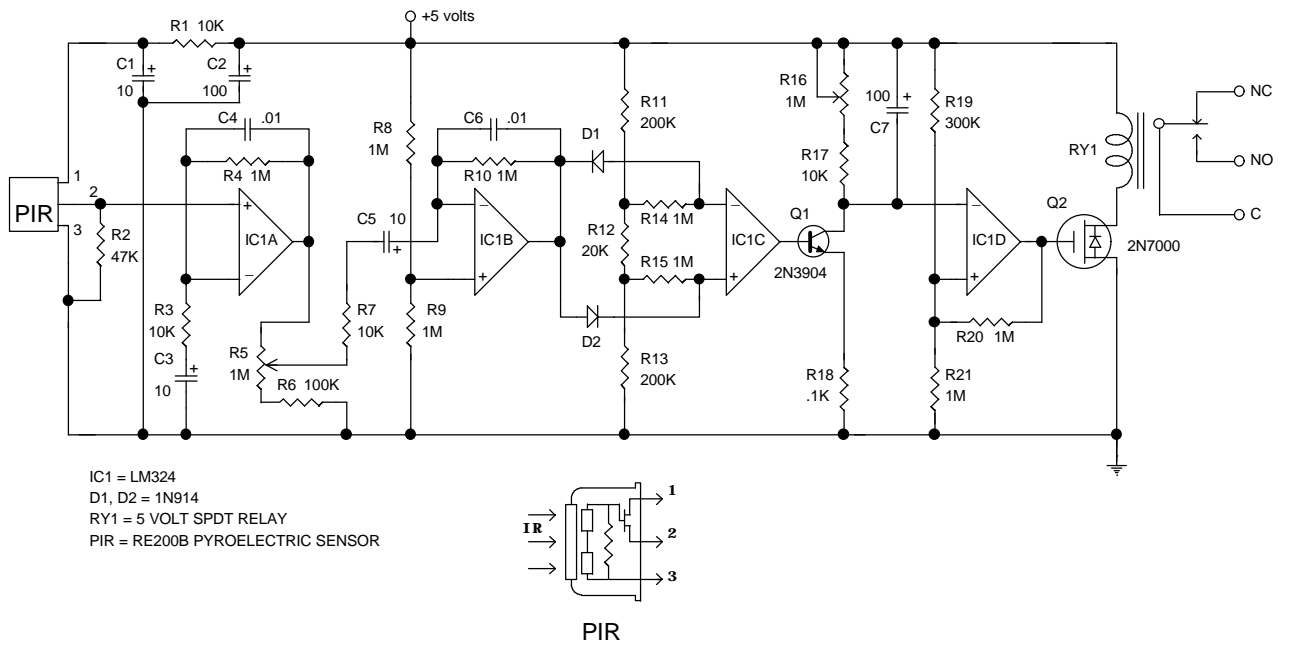

FIGURE 3



APPLICATION CIRCUIT FIGURE 4

Fresnel Lens_____

A Fresnel lens is a Plano Convex lens that has been collapsed on itself as in figure 5 to form a flat lens that retains its optical characteristics but is much smaller in size and has less absorption losses.

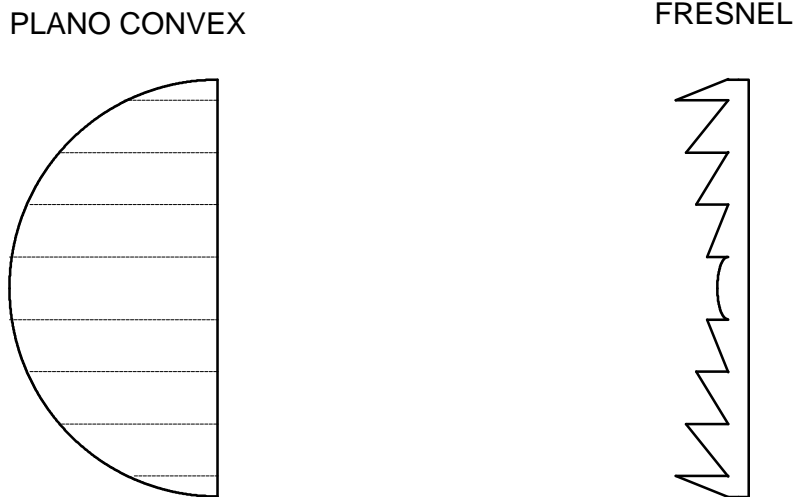
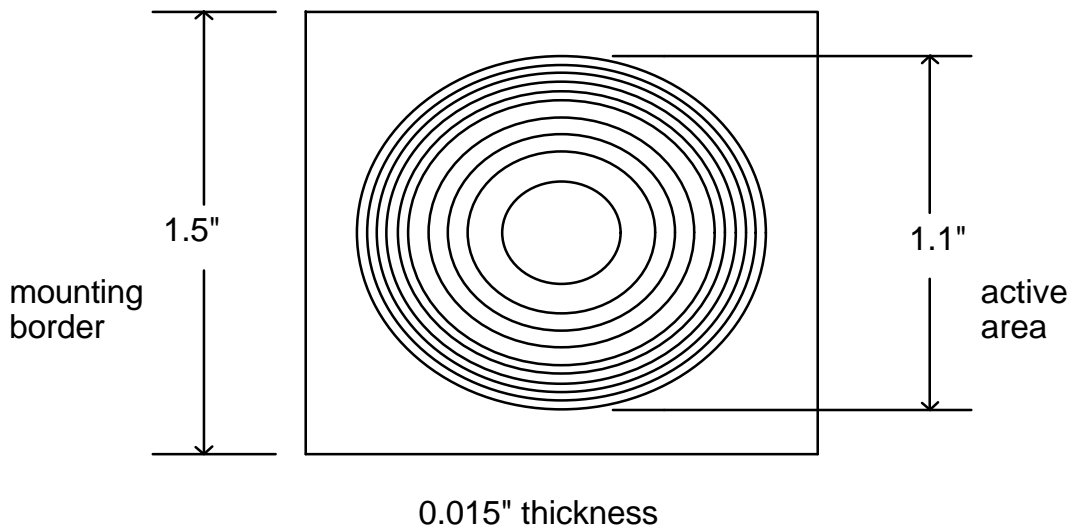
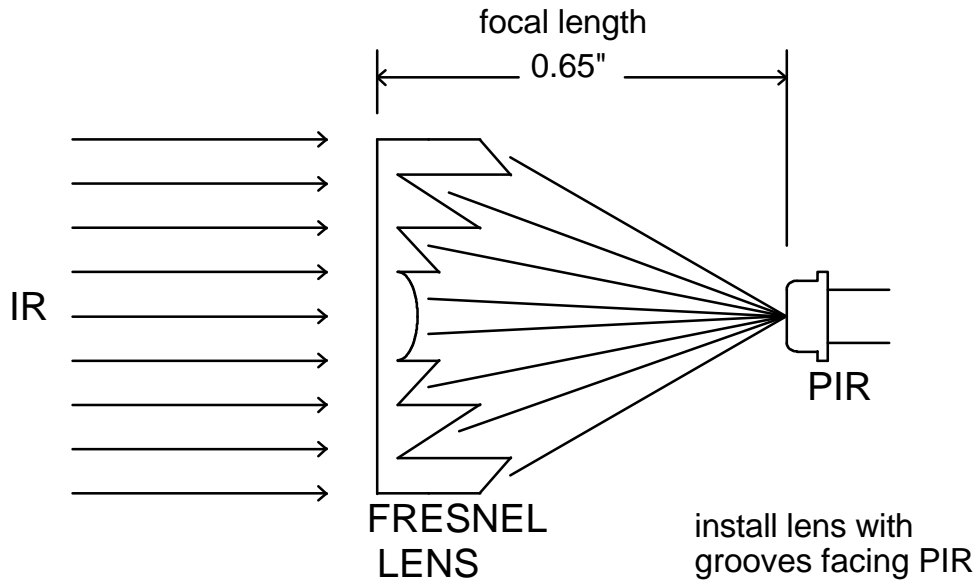

FIGURE 5

The FL65 Fresnel lens is made of an infrared transmitting material that has an IR transmission range of 8 to 14 μm which is most sensitive to human body radiation. It is designed to have its grooves facing the IR sensing element so that a smooth surface is presented to the subject side of the lens which is usually the outside of an enclosure housing the sensor.

The lens element is round with a diameter of 1 inch and has a flange that is 1.5 inches square. This flange is used for mounting the lens in a suitable frame or enclosure. Mounting can best and most easily be done with strips of Scotch tape. Cyanoacrylate cement (crazy glue) can also be used, however, be sure to allow at least 72 hours drying time before the lens is placed in an enclosure to prevent etching of the lens due to trapped adhesive fumes.

The FL65 has a focal length of 0.65 inches from the lens to the sensing element. It has been determined by experiment to have a field of view of approximately 10 degrees when used with a RE200B Pyroelectric sensor. Figure 6 shows the lens dimensions.



Optimum transmittance in the 8 to 14 um region

FIGURE 6

S211FL Machined Enclosure for use with FL65 Fresnel Lens

S211FL

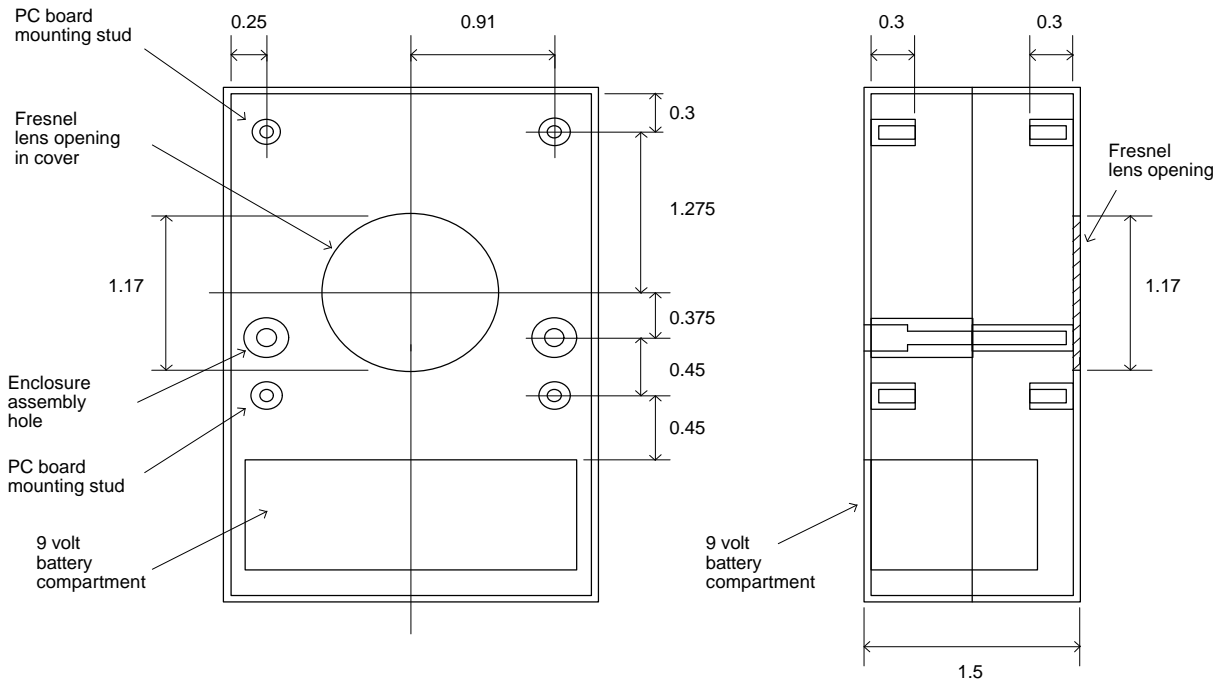

All dimensions are in inches and are approximate

Attach Fresnel lens to the inside of enclosure with grooves facing in.
Align lens so active area is well centered over opening .
Lens may be held in place with tape around edges of flange or with
a few drops of cyanoacrylate cement placed on edges of flange

FIGURE 7

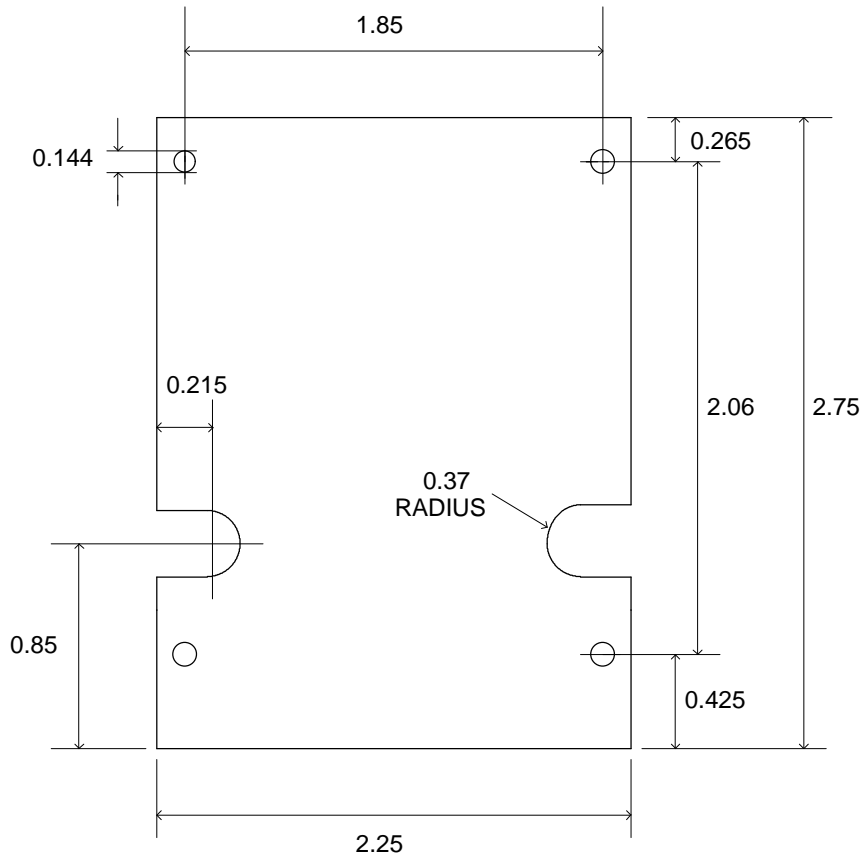

DIMENSIONS OF PRINTED CIRCUIT BOARD
FOR S211FL ENCLOSURE

FIGURE 8



GLOLAB

CORPORATION

134 Van Voorhis
Wappingers Falls, NY 12590
voice - (914) 297-9771
Fax - (914) 297-9772
Email - lab@glolab.com
<http://www.glolab.com>
© 1999 Glolab Corp.