

AN1318

Interfacing Semiconductor Pressure Sensors to Microcomputers

Prepared by: Warren Schultz
Discrete Applications Engineering

INTRODUCTION

The most popular silicon pressure sensors are piezoresistive bridges that produce a differential output voltage in response to pressure applied to a thin silicon diaphragm. Output voltage for these sensors is generally 25 to 50 mV full scale. Interface to microcomputers, therefore, generally involves gaining up the relatively small output voltage, performing a differential to single ended conversion, and scaling the analog signal into a range appropriate for analog to digital conversion. Alternately, the analog pressure signal can be converted to a frequency modulated 5 V waveform or 4–20 mA current loop, either of which is relatively immune to noise on long interconnect lines.

A variety of circuit techniques that address interface design are presented. Sensing amplifiers, analog to digital conversion, frequency modulation and 4–20 mA current loops are considered.

PRESSURE SENSOR BASICS

The essence of piezoresistive pressure sensors is the Wheatstone bridge shown in Figure 1. Bridge resistors RP1, RP2, RV1 and RV2 are arranged on a thin silicon diaphragm such that when pressure is applied RP1 and RP2 increase in value while RV1 and RV2 decrease a similar amount. Pressure on the diaphragm, therefore, unbalances the bridge and produces a differential output signal. One of the fundamental properties of this structure is that the differential output voltage is directly proportional to bias voltage B+. This characteristic implies that the accuracy of the pressure measurement depends directly on the tolerance of the bias supply. It also provides a convenient means for temperature compensation. The bridge resistors are silicon resistors that have positive temperature coefficients. Therefore, when they are placed in series with zero T_C temperature compensation resistors RC1 and RC2 the amount of voltage applied to the bridge increases with temperature. This increase in voltage produces an increase in electrical sensitivity which offsets and compensates for the negative temperature coefficient associated with piezoresistance.

Since RC1 and RC2 are approximately equal, the output voltage common mode is very nearly fixed at 1/2 B+. In a typical MPX2100 sensor, the bridge resistors are nominally 425 ohms; RC1 and RC2 are nominally 680 ohms. With these values and 10 V applied to B+, a delta R of 1.8 ohms at full scale pressure produces 40 mV of differential output voltage.

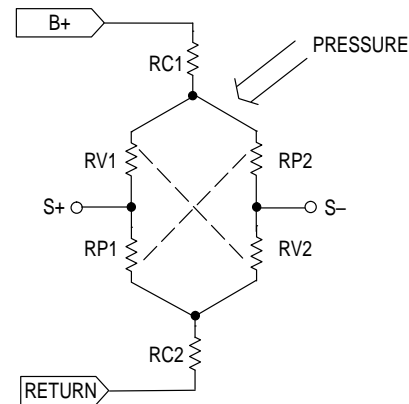

Figure 1. Sensor Equivalent Circuit

INSTRUMENTATION AMPLIFIER INTERFACES

Instrumentation amplifiers are by far the most common interface circuits that are used with pressure sensors. An example of an inexpensive instrumentation amplifier based interface circuit is shown in Figure 2. It uses an MC33274 quad operational amplifier and several resistors that are configured as a classic instrumentation amplifier with one important exception. In an instrumentation amplifier resistor R3 is normally returned to ground. Returning R3 to ground sets the output voltage for zero differential input to 0 V DC. For microcomputer interface a positive offset voltage on the order of 0.3 to 0.8 V is generally desired. Therefore, R3 is connected to pin 14 of U1D which supplies a buffered offset voltage that is derived from the wiper of R6. This voltage establishes a DC output for zero differential input. The translation is one to one. Within the tolerances of the circuit, whatever voltage appears at the wiper of R6 will also appear as the zero pressure DC offset voltage at the output.

With R10 at 240 ohms, gain is set for a nominal value of 125. This provides a 4 V span for 32 mV of full scale sensor output. Setting the offset voltage to .75 V results in a 0.75 V to 4.75 V output that is directly compatible with microprocessor A/D inputs. Over a zero to 50° C temperature range, combined accuracy for an MPX2000 series sensor and this interface is on the order of ± 10%.

AN1318

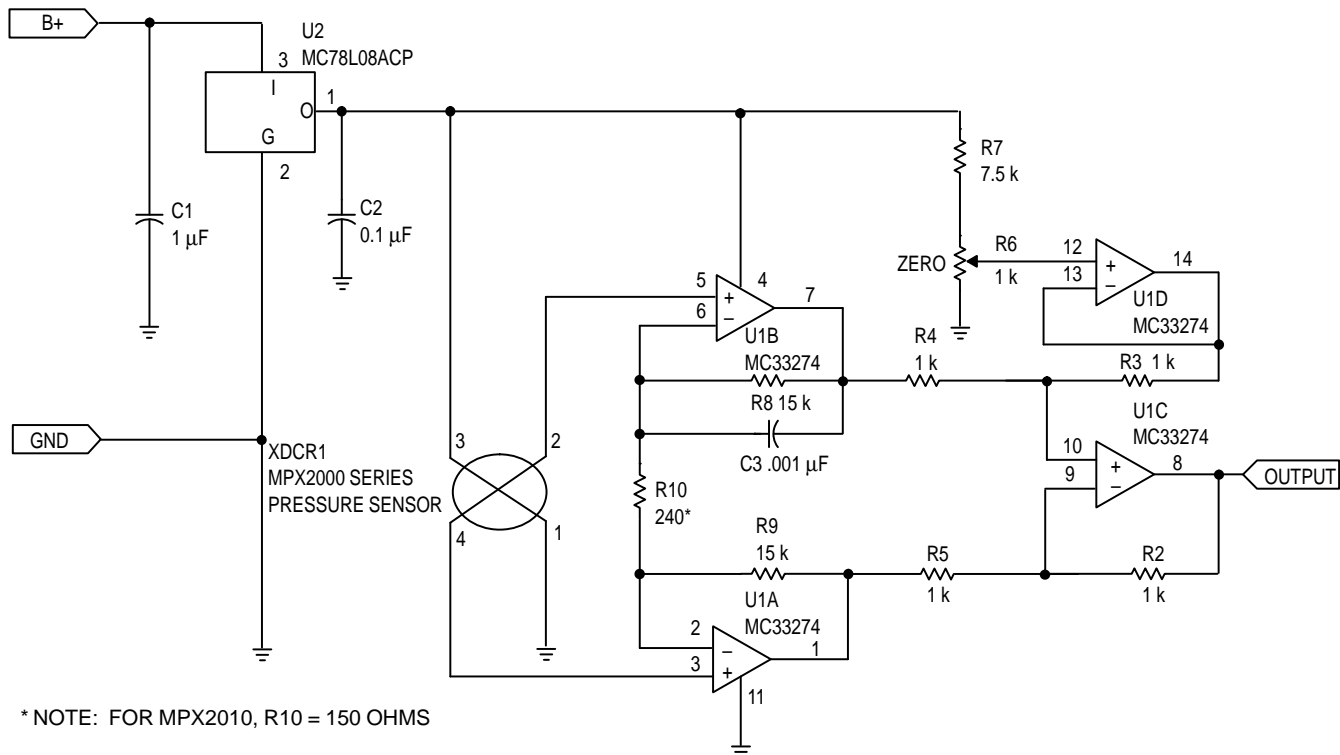

Figure 2. Instrumentation Amplifier Interface

For applications requiring greater precision a fully integrated instrument amplifier such as an LTC1100CN8 gives better results. In Figure 3 one of these amplifiers is used to provide a gain of 100, as well as differential to single ended conversion. Zero offset is provided by dividing down the precision reference to 0.5 V and buffering with U2B. This voltage is fed into the LTC1100CN8's ground pin which is equivalent to returning R3 to pin 14 of U1D in Figure 2. An additional non-inverting gain stage consisting of U2A, R1 and R2 is used to scale the sensor's full scale span to 4 V. R2 is also returned to the buffered .5 V to maintain the 0.5 V zero offset that was established in the instrumentation amplifier. Output voltage range is therefore 0.5 to 4.5 V.

Both of these instrumentation amplifier circuits do their intended job with a relatively straightforward tradeoff between cost and performance. The circuit of Figure 2 has the usual cumulative tolerance problem that is associated with instrumentation amplifiers that have discrete resistors, but it has a relatively low cost. The integrated instrumentation amplifier in Figure 3 solves this problem with precision trimmed film resistors and also provides superior input offset performance. Component cost, however, is significantly higher.

SENSOR SPECIFIC INTERFACE AMPLIFIER

A low cost interface designed specifically for pressure sensors improves upon the instrumentation amplifier in Figure 2. Shown in Figure 4, it uses one quad op amp and several resistors to amplify and level shift the sensor's output. Most of the amplification is done in U1A which is configured as a differential amplifier. It is isolated from the sensor's positive output by U1B. The purpose of U1B is to prevent feedback current that flows through R5 and R6 from flowing into the sensor. At zero pressure the voltage from pin 2 to pin 4 on the sensor is 0 V. For example, let's say that the common mode voltage on these pins is 4.0 V. The zero pressure output voltage at pin 1 of U1A is then 4.0 V, since any other voltage would be coupled back to pin 2 via R6 and create a non-zero bias across U1A's differential inputs. This 4.0 V zero pressure DC output voltage is then level translated to the desired zero pressure offset voltage (V_{OFFSET}) by U1C and U1D.

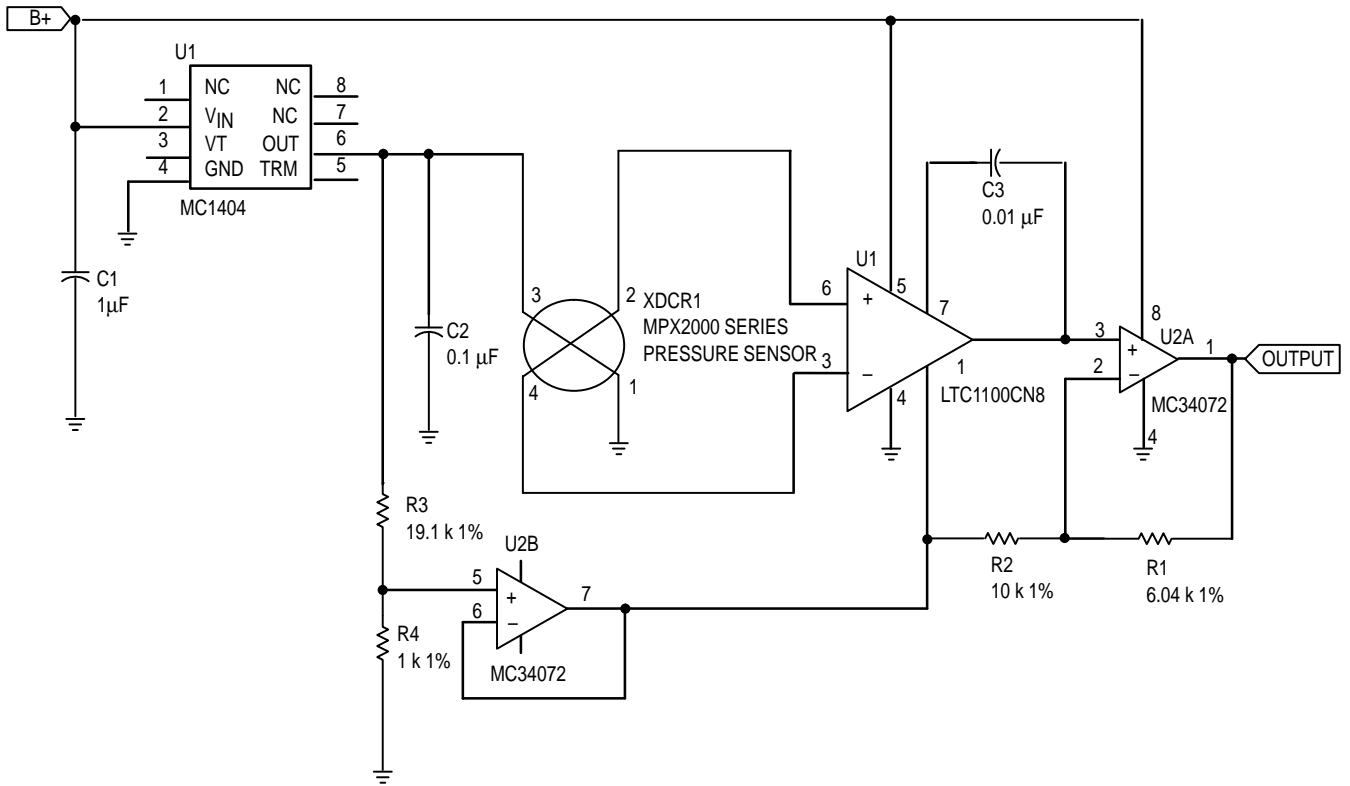
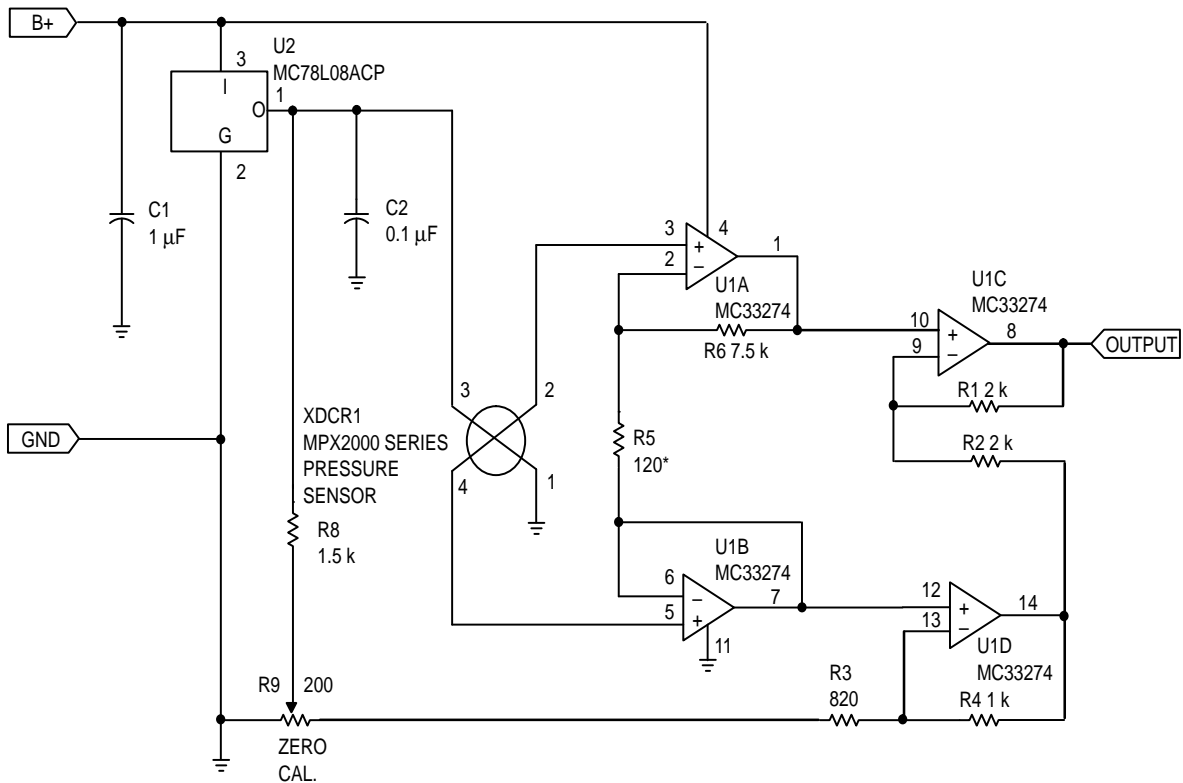

Figure 3. Precision Instrument Amplifier Interface



* NOTE: FOR MPX2010, R5 = 75 OHMS

Figure 4. Sensor Specific Interface Circuit

AN1318

To see how the level translation works, let's look at the simplified schematic in Figure 5. Again assuming a common mode voltage of 4.0 V, the voltage applied to pin 12 of U1D is 4.0 V, implying that pin 13 is also at 4.0 V. This leaves 4.0 V – V_{OFFSET} across R3, which is 3.5 V if V_{OFFSET} is set to 0.5 V. Since no current flows into pin 13, the same current flows through both R3 and R4. With both of these resistors set to the same value, they have the same voltage drop, implying a 3.5 V drop across R4. Adding the voltages (0.5 + 3.5 + 3.5) yields

7.5 V at pin 14 of U1D. Similarly 4.0 V at pin 10 of U1C implies 4.0 V at pin 9, and the drop across R2 is 7.5 V – 4.0 V = 3.5 V. Again 3.5 V across R2 implies an equal drop across R1, and the voltage at pin 8 is 4.0 V – 3.5 V = .5 V. For this DC output voltage to be independent of the sensor's common mode voltage it is necessary to satisfy the condition that $R4/R3 = R2/R1$. In Figure 4, V_{OFFSET} is produced by R8 and adjustment pot R9. R3's value is adjusted such that the total source impedance into pin 13 is approximately 1 k.

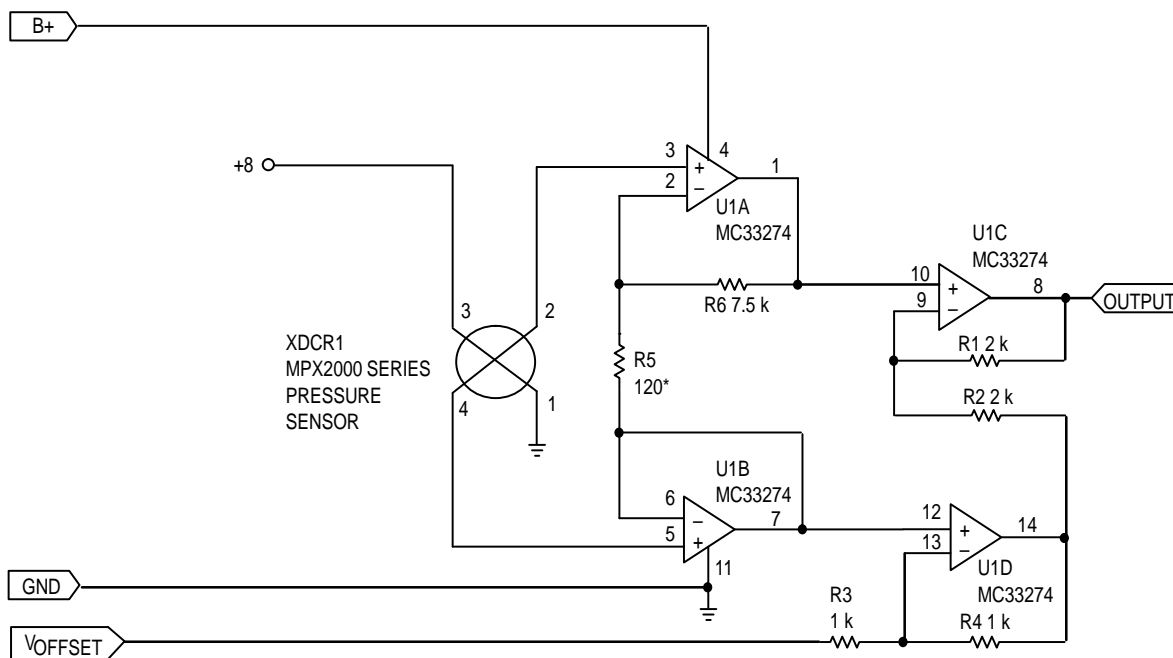

*NOTE: FOR MPX2010, R5 = 75 OHMS

Figure 5. Simplified Sensor Specific Interface

Gain is approximately $(R6/R5)(R1/R2+1)$, which is 125 for the values shown in Figure 4. A gain of 125 is selected to provide a 4 V span for the 32 mV of full scale sensor output that is obtained with 8 V B+.

The resulting 0.5 V to 4.5 V output from U1C is preferable to the 0.75 to 4.75 V range developed by the instrument amplifier configuration in Figure 2. It also uses fewer parts. This circuit does not have the instrument amplifier's propensity for oscillation and therefore does not require compensation capacitor C3 that is shown in Figure 2. It also requires one less resistor, which in addition to reducing component count also reduces accumulated tolerances due to resistor variations.

This circuit as well as the instrumentation amplifier interfaces in Figures 2 and 3 is designed for direct connection to a

microcomputer A/D input. Using the MC68HC11 as an example, the interface circuit output is connected to any of the E ports, such as port E0 as shown in Figure 6. To get maximum accuracy from the A/D conversion, V_{REFH} is tied to 4.85 V and V_{REFL} is tied to 0.30 V by dividing down a 5 V reference with 1% resistors.

SINGLE SLOPE A/D CONVERTER

The 8 bit A/D converters that are commonly available on chip in microcomputers are usually well suited to pressure sensing applications. In applications that require more than 8 bits, the circuit in Figure 7 extends resolution to 11 bits with an external analog-to-digital converter. It also provides an interface to digital systems that do not have an internal A/D function.

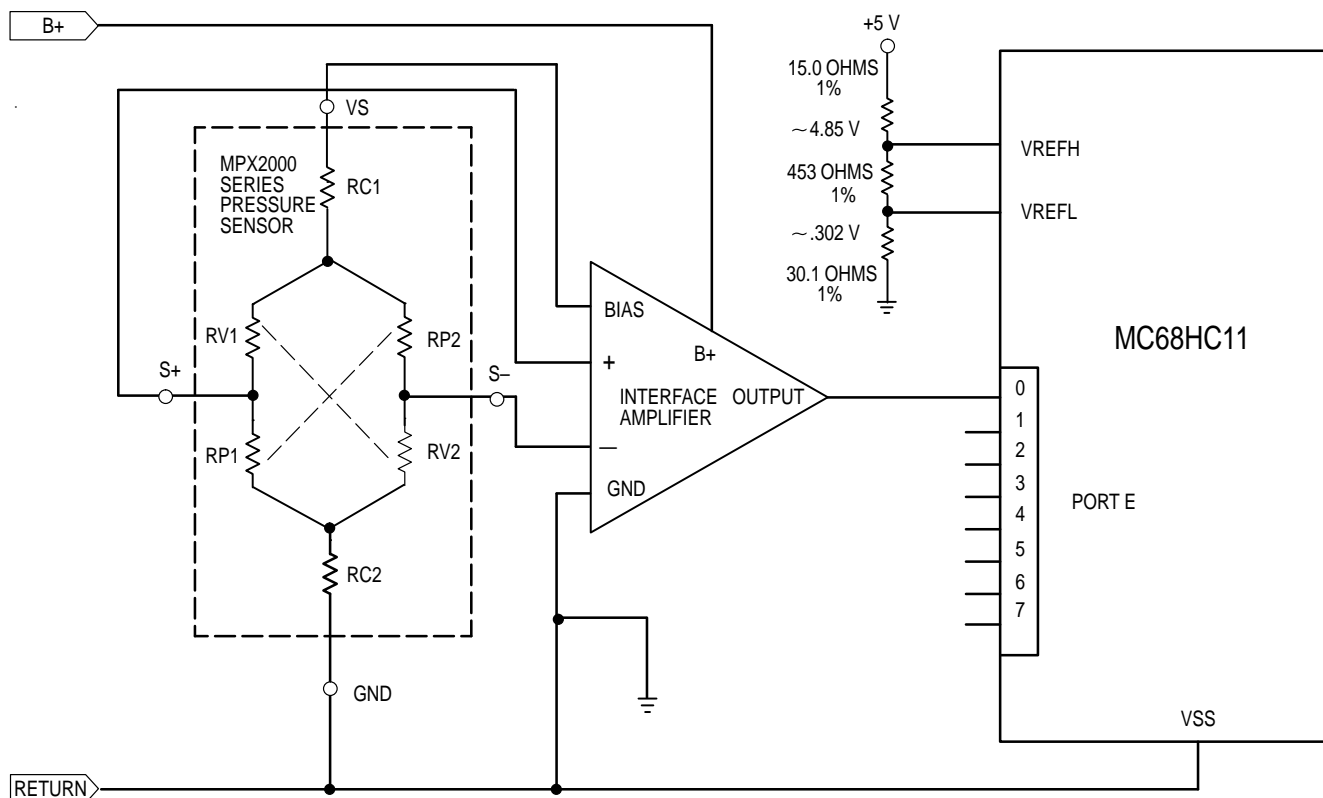

Figure 6. Application Example

Beginning with the ramp generator, a timing ramp is generated with current source U5 and capacitor C3. Initialization is provided by Q1 which sets the voltage on C3 at approximately ground. With the values shown, 470 μA flowing into 0.47 μF provide approximately a 5 msec ramp time from zero to 5 V. Assuming zero pressure on the sensor, inputs to both comparators U2A and U2B are at the same voltage. Therefore, as the ramp voltage sweeps from zero to 5 V, both PA0 and PA1 will go low at the same time when the ramp voltage exceeds the common mode voltage. The processor counts the number of clock cycles between the time that PA0 and PA1 go low, reading zero for zero pressure.

In this circuit, U4A and U4B form the front end of an instrument amplifier. They differentially amplify the sensor's output. The resulting amplified differential signal is then sampled and held in U1 and U3. The sample and hold function is performed in order to keep input data constant during the conversion process. The stabilized signals coming out of U1 and U3 feed a higher output voltage to U2A than U2B, assuming that pressure is applied to the sensor. Therefore, the ramp will trip U2B before U2A is tripped, creating a time difference between PA0 going low and PA1 going low. The processor reads the number of clock cycles between these two events. This number is then linearly scaled with software to represent the amplified output voltage, accomplishing the analog to digital conversion.

When the ramp reaches the reference voltage established by R9 and R10, comparator U2C is tripped, and a reset command is generated. To accomplish reset, Q1 is turned on

with an output from PA7, and the sample and hold circuits are delatched with an output from PB1. Resolution is limited by clock frequency and ramp linearity. With the ramp generator shown in Figure 7 and a clock frequency of 2 MHz; resolution is 11 bits.

From a software point of view, the A/D conversion consists of latching the sample and hold, reading the value of the microcomputer's free running counter, turning off Q1, and waiting for the three comparator outputs to change state from logic 1 to logic 0. The analog input voltage is determined by counting, in 0.5 μsec steps, the number of clock cycles between PA0 and PA1 going low.

LONG DISTANCE INTERFACES

In applications where there is a significant distance between the sensor and microcomputer, two types of interfaces are typically used. They are frequency output and 4–20 mA loops. In the frequency output topology, pressure is converted into a zero to 5 V digital signal whose frequency varies linearly with pressure. A minimum frequency corresponds to zero pressure and above this, frequency output is determined by a Hz/unit pressure scaling factor. If minimizing the number of wires to a remote sensor is the most important design consideration, 4–20 mA current loops are the topology of choice. These loops utilize power and ground as the 4–20 mA signal line and therefore require only two wires to the sensor. In this topology 4 mA of total current drain from the sensor corresponds to zero pressure, and 20 mA to full scale.

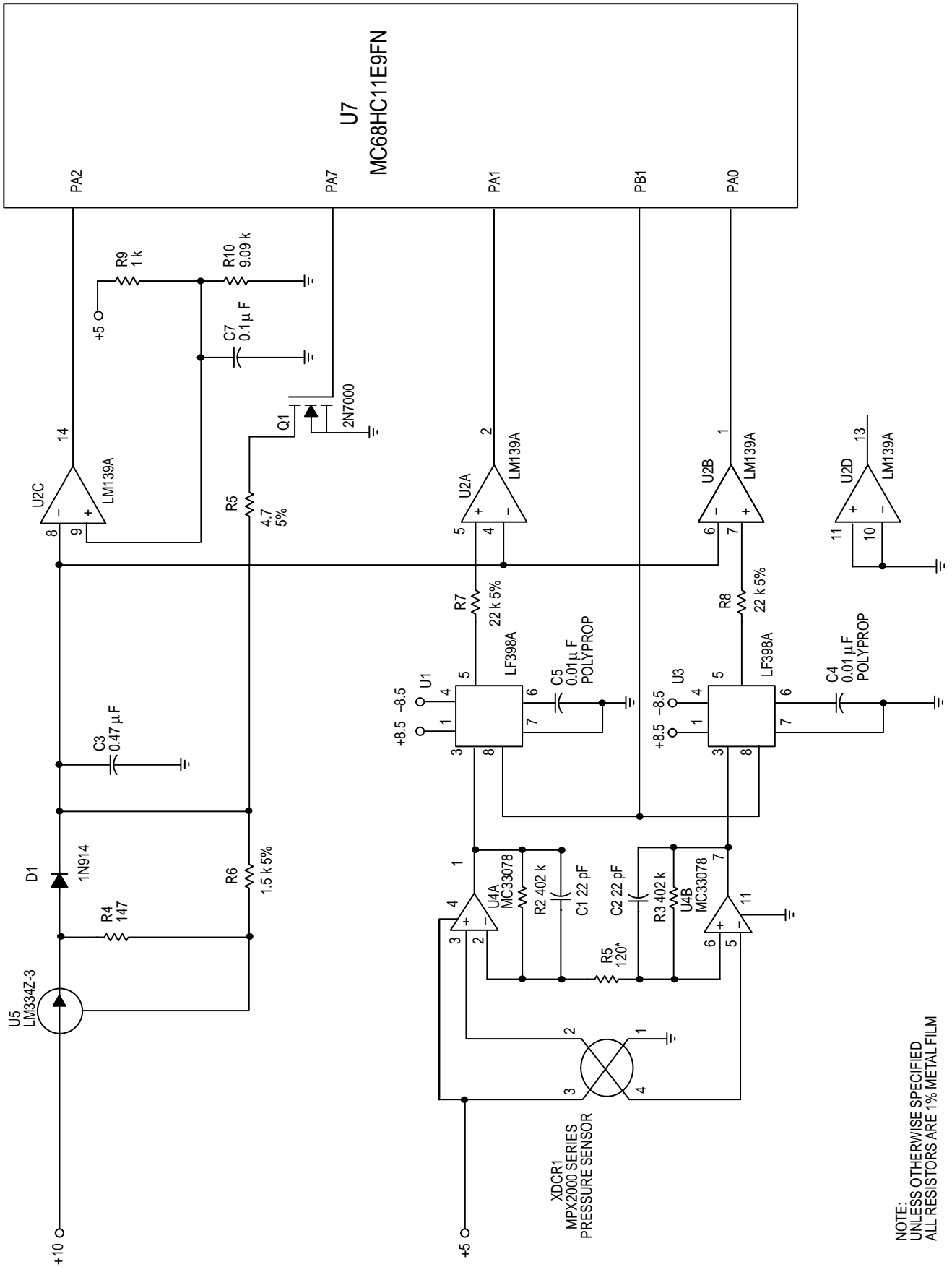

Figure 7. Single Slope A/D Converter

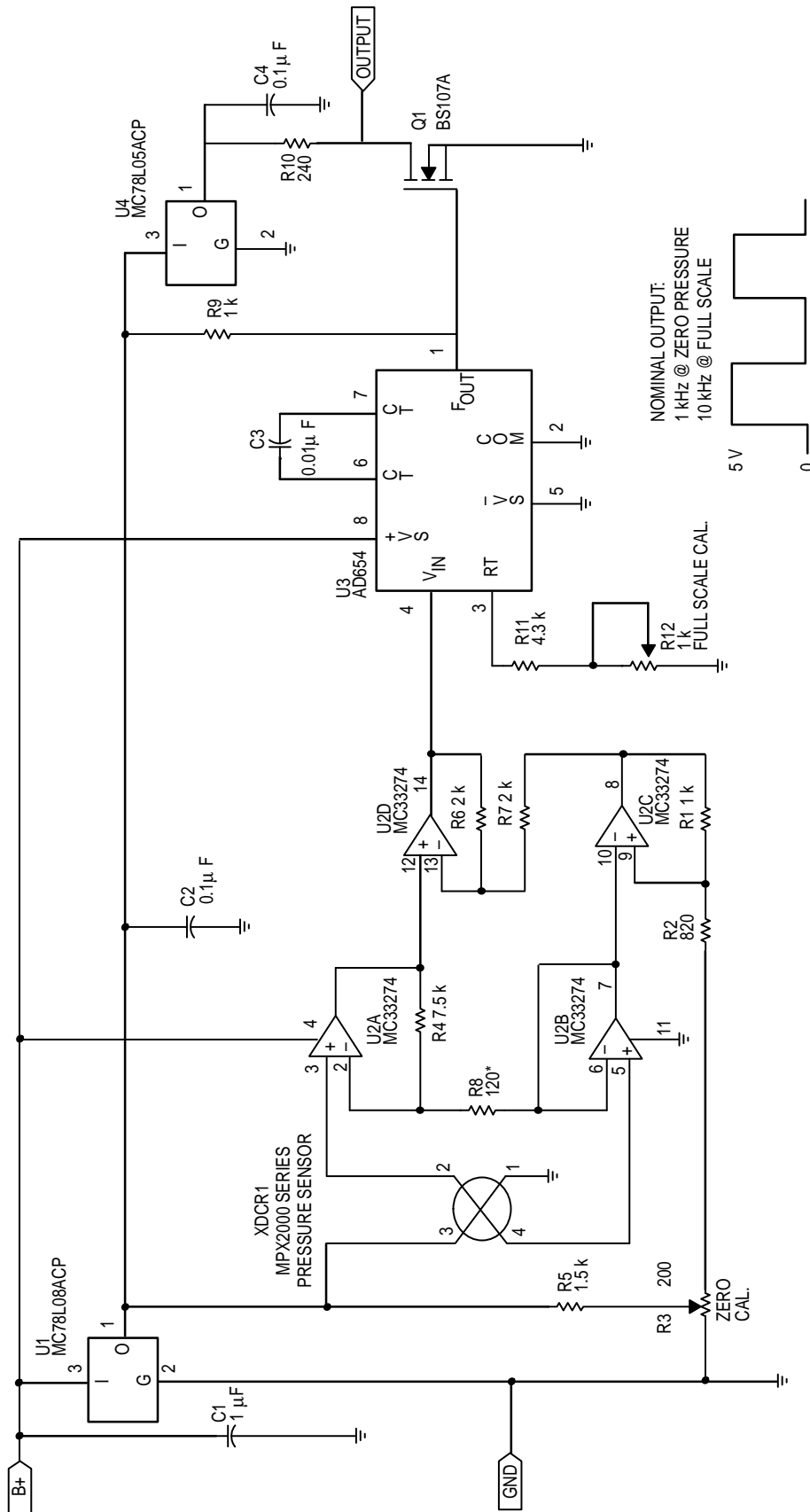

Figure 8. Frequency Output Pressure Sensor

AN1318

A relatively straightforward circuit for converting pressure to frequency is shown in Figure 8. It consists of three basic parts. The interface amplifier is the same circuit that was described in Figure 4. Its 0.5 to 4.5 V output is fed directly into an AD654 voltage-to-frequency converter. On the AD654, C3 sets nominal output frequency. Zero pressure output is calibrated to 1 kHz by adjusting the zero pressure input voltage with R3. Full scale adjustments are made with R12 which sets the full scale frequency to 10 kHz. The output of the AD654 is then fed into a buffer consisting of Q1 and R10. The buffer is used to clean up the edges and level translate the output to 5 V. Advantages of this approach are that the frequency output is easily read by a microcomputer's timer and transmission over

a twisted pair line is relatively easy. Where very long distances are involved, the primary disadvantage is that 3 wires (V_{CC} , ground and an output line) are routed to the sensor.

A 4–20 mA loop reduces the number of wires to two. Its output is embedded in the V_{CC} and ground lines as an active current source. A straightforward way to apply this technique to pressure sensing is shown in Figure 9. In this figure an MPX7000 series high impedance pressure sensor is mated to an XTR101 4–20 mA two-wire transmitter. It is set up to pull 4 mA from its power line at zero pressure and 20 mA at full scale. At the receiving end a 240 ohm resistor referenced to signal ground will provide a 0.96 to 4.8 V signal that is suitable for microcomputer A/D inputs.

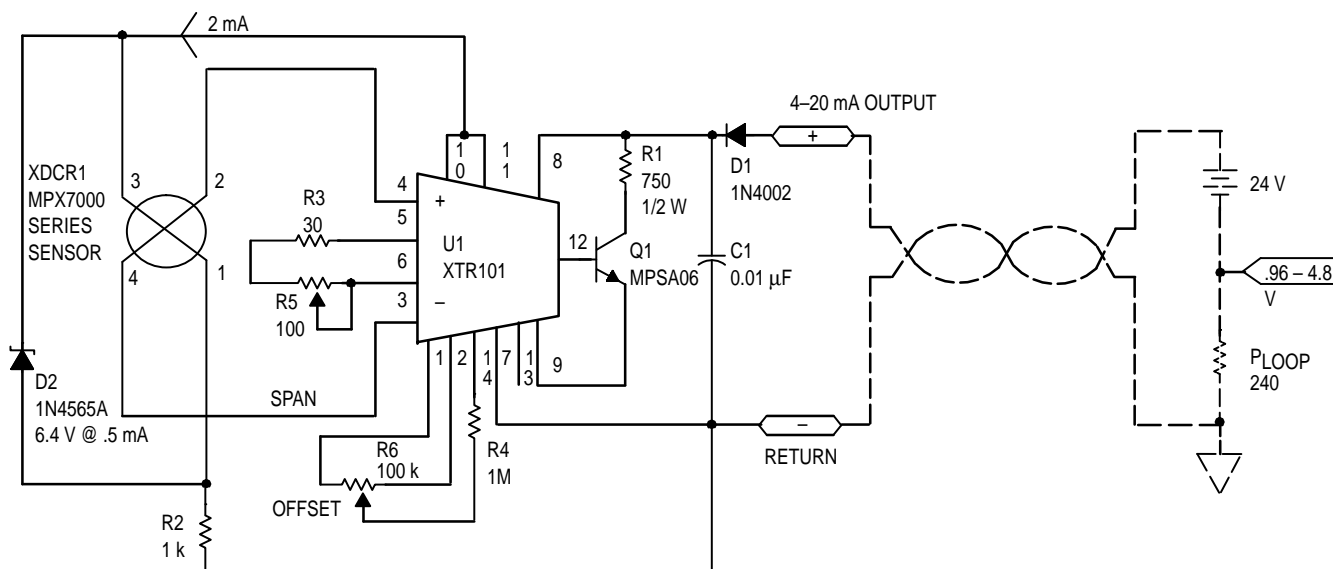

Figure 9. 4–20 mA Pressure Transducer

Bias for the sensor is provided by two 1 mA current sources (pins 10 and 11) that are tied in parallel and run into a 1N4565A 6.4 V temperature compensated zener reference. The sensor's differential output is fed directly into XTR101's inverting and non-inverting inputs. Zero pressure offset is calibrated to 4 mA with R6. Biased with 6.4 V, the sensor's full scale output is 24.8 mV. Given this input $R3 + R5$ nominally total 64 ohms to produce the 16 mA span required for 20 mA full scale. Calibration is set with R5.

The XTR101 requires that the differential input voltage at pins

3 and 4 has a common mode voltage between 4 and 6 V. The sensor's common mode voltage is one half its supply voltage or 3.2 V. R2 boosts this common mode voltage by $1\text{ k} \cdot 2\text{ mA}$ or 2 V, establishing a common mode voltage for the transmitter's input of 5.2 V. To allow operation over a 12 to 40 V range, dissipation is off-loaded from the IC by boosting the output with Q1 and R1. D1 is also included for protection. It prohibits reverse polarity from causing damage. Advantages of this topology include simplicity and, of course, the two wire interface.

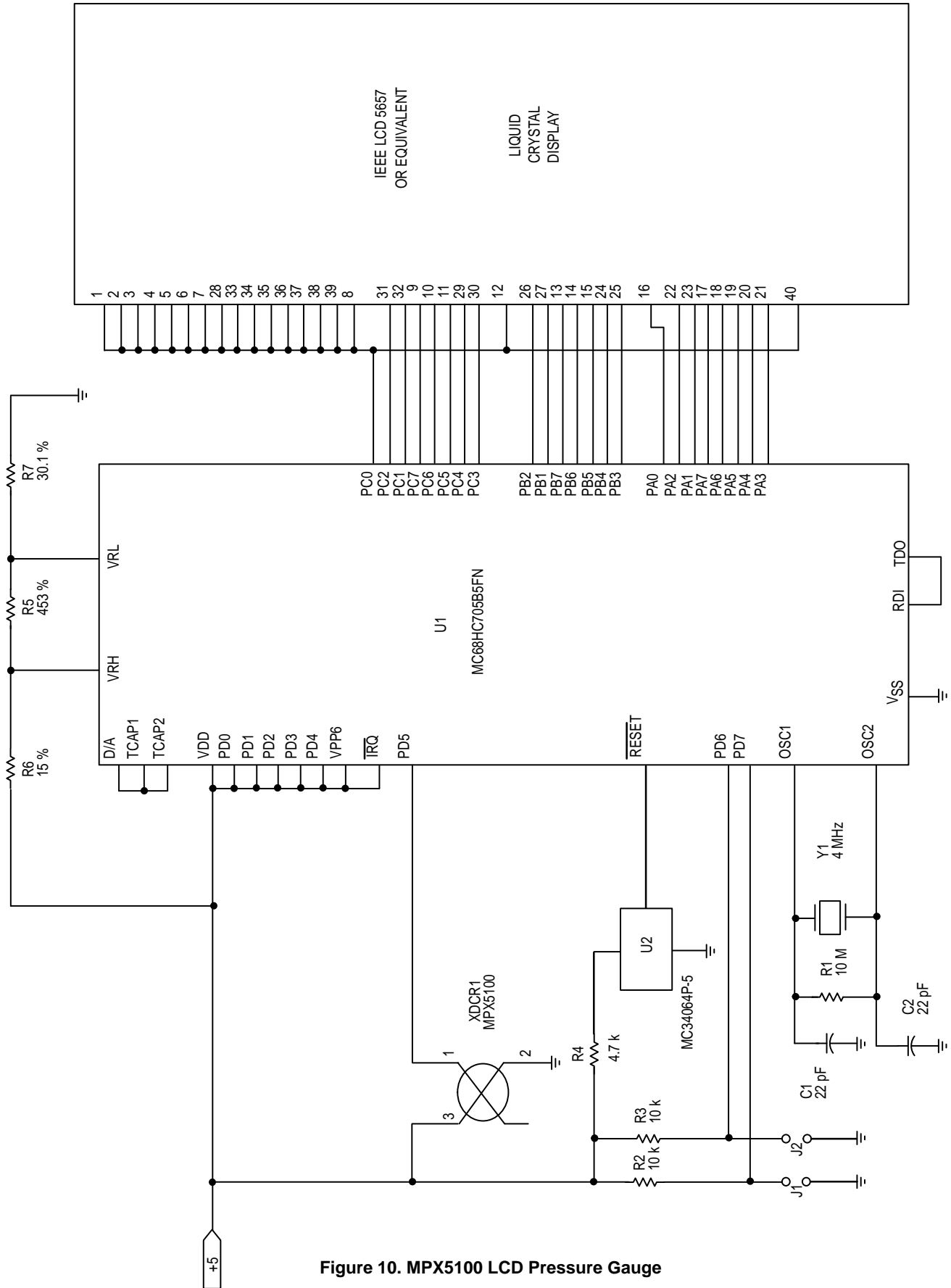

Figure 10. MPX5100 LCD Pressure Gauge

DIRECT INTERFACE WITH INTEGRATED SENSORS

The simplest interface is achieved with an integrated sensor and a microcomputer that has an on-chip A/D converter. Figure 10 shows an LCD pressure gauge that is made with an MPX5100 integrated sensor and MC68HC05 microcomputer. Although the total schematic is reasonably complicated, the interface between the sensor and the micro is a single wire. The MPX5100 has an internal amplifier that outputs a 0.5 to 4.5 V signal that inputs directly to A/D port PD5 on the HC05.

The software in this system is written such that the processor assumes zero pressure at power up, reads the sensor's output voltage, and stores this value as zero pressure offset. Full scale span is adjustable with jumpers J1 and J2. For this particular system the software is written such that with J1 out and J2 in, span is decreased by 1.5%. Similarly with J1 in and J2 out, span is increased by 1.5%. Given the $\pm 2.5\%$ full scale spec on the sensor, these jumpers allow calibration to $\pm 1\%$ without the use of pots.

MIX AND MATCH

The circuits that have been described so far are intended to be used as functional blocks. They may be combined in a variety of ways to meet the particular needs of an application. For example, the Frequency Output Pressure Sensor in Figure 8 uses the sensor interface circuit described in Figure 4 to provide an input to the voltage-to-frequency converter. Alternately, an MPX5100 could be directly connected to pin 4 of the AD654 or the output of Figure 3's Precision Instrumentation Amplifier Interface could be substituted in the same way. Similarly, the Pressure Gauge described in Figure 10 could be constructed with any of the interfaces that have been described.

CONCLUSION

The circuits that have been shown here are intended to make interfacing semiconductor pressure sensors to digital systems easier. They provide cost effective and relatively simple ways of interfacing sensors to microcomputers. The seven different circuits contain many tradeoffs that can be matched to the needs of individual applications. When considering these tradeoffs it is important to throw software into the equation. Techniques such as automatic zero pressure calibration can allow one of the inexpensive analog interfaces to provide performance that could otherwise only be obtained with a more costly precision interface.

REFERENCES

1. Baum, Jeff, "Frequency Output Conversion for MPX2000 Series Pressure Sensors," Motorola Application Note AN1316/D.
2. Lucas, William, "An Evaluation System for Direct Interface of the MPX5100 Pressure Sensor with a Microprocessor," Motorola Application Note AN1305.
3. Lucas, William, "An Evaluation System for Interfacing the MPX2000 Series Pressure Sensors to a Microprocessor," Motorola Application Note AN1315.
4. Schultz, Warren, "Compensated Sensor Bar Graph Pressure Gauge," Motorola Application Note AN1309.
5. Schultz, Warren, "Interfaced Sensor Evaluation Board," Motorola Application Note AN1312.
6. Schultz, Warren, "Sensor Building Block Evaluation Board," Motorola Application Note AN1313.
7. Williams, Denise, "A Simple 4–20 mA Pressure Transducer Evaluation Board," Motorola Application Note AN1303.

Motorola reserves the right to make changes without further notice to any products herein. Motorola makes no warranty, representation or guarantee regarding the suitability of its products for any particular purpose, nor does Motorola assume any liability arising out of the application or use of any product or circuit, and specifically disclaims any and all liability, including without limitation consequential or incidental damages. "Typical" parameters which may be provided in Motorola data sheets and/or specifications can and do vary in different applications and actual performance may vary over time. All operating parameters, including "Typicals" must be validated for each customer application by customer's technical experts. Motorola does not convey any license under its patent rights nor the rights of others. Motorola products are not designed, intended, or authorized for use as components in systems intended for surgical implant into the body, or other applications intended to support or sustain life, or for any other application in which the failure of the Motorola product could create a situation where personal injury or death may occur. Should Buyer purchase or use Motorola products for any such unintended or unauthorized application, Buyer shall indemnify and hold Motorola and its officers, employees, subsidiaries, affiliates, and distributors harmless against all claims, costs, damages, and expenses, and reasonable attorney fees arising out of, directly or indirectly, any claim of personal injury or death associated with such unintended or unauthorized use, even if such claim alleges that Motorola was negligent regarding the design or manufacture of the part. Motorola and  are registered trademarks of Motorola, Inc. Motorola, Inc. is an Equal Opportunity/Affirmative Action Employer.

Mfax is a trademark of Motorola, Inc.

How to reach us:

USA/EUROPE/Locations Not Listed: Motorola Literature Distribution;
P.O. Box 5405, Denver, Colorado 80217. 303-675-2140 or 1-800-441-2447

JAPAN: Nippon Motorola Ltd.; Tatsumi-SPD-JLDC, 6F Seibu-Butsuryu-Center,
3-14-2 Tatsumi Koto-Ku, Tokyo 135, Japan. 81-3-3521-8315

Mfax™: RMFAX0@email.sps.mot.com – TOUCHTONE 602-244-6609
– US & Canada ONLY 1-800-774-1848

ASIA/PACIFIC: Motorola Semiconductors H.K. Ltd.; 8B Tai Ping Industrial Park,
51 Ting Kok Road, Tai Po, N.T., Hong Kong. 852-26629298

INTERNET: <http://motorola.com/sps>

