



AP-155

**APPLICATION
NOTE**

Oscillators for Microcontrollers

**TOM WILLIAMSON
MICROCONTROLLER
TECHNICAL MARKETING**

June 1983



Order Number: 230659-001

Information in this document is provided in connection with Intel products. Intel assumes no liability whatsoever, including infringement of any patent or copyright, for sale and use of Intel products except as provided in Intel's Terms and Conditions of Sale for such products.

Intel retains the right to make changes to these specifications at any time, without notice. Microcomputer Products may have minor variations to this specification known as errata.

*Other brands and names are the property of their respective owners.

†Since publication of documents referenced in this document, registration of the Pentium, OverDrive and iCOMP trademarks has been issued to Intel Corporation.

Contact your local Intel sales office or your distributor to obtain the latest specifications before placing your product order.

Copies of documents which have an ordering number and are referenced in this document, or other Intel literature, may be obtained from:

Intel Corporation
P.O. Box 7641
Mt. Prospect, IL 60056-7641
or call 1-800-879-4683

OSCILLATORS FOR MICROCONTROLLERS

CONTENTS	PAGE
INTRODUCTION	1
FEEDBACK OSCILLATORS	1
Loop Gain	1
How Feedback Oscillators Work	2
The Positive Reactance Oscillator	2
QUARTZ CRYSTALS	3
Crystal Parameters	3
Equivalent Circuit	3
Load Capacitance	4
“Series” vs. “Parallel” Crystals	4
Equivalent Series Resistance	4
Frequency Tolerance	5
Drive Level	5
CERAMIC RESONATORS	5
Specifications for Ceramic Resonators	6
OSCILLATOR DESIGN CONSIDERATIONS	6
On-Chip Oscillators	6
Crystal Specifications	6
Oscillation Frequency	7
Selection of CX1 and CX2	7
Placement of Components	7
Clocking Other Chips	7
External Oscillators	8
Gate Oscillators vs. Discrete Devices	10
Fundamental vs. Overtone Operation	11
“Series” vs. “Parallel” Operation	11



CONTENTS	PAGE
MORE ABOUT USING THE “ON-CHIP” OSCILLATORS	11
Oscillator Calculations	11
Start-Up Characteristics	13
Steady-State Characteristics	15
Pin Capacitance	16
MCS®-51 Oscillator	16
MCS®-48 Oscillator	16

CONTENTS	PAGE
Pre-Production Tests	19
Troubleshooting Oscillator Problems	20
APPENDIX A: QUARTZ AND CERAMIC RESONATOR FORMULAS	A-1
APPENDIX B: OSCILLATOR ANALYSIS PROGRAM	B-1



INTRODUCTION

Intel's microcontroller families (MCS[®]-48, MCS[®]-51, and iACX-96) contain a circuit that is commonly referred to as the "on-chip oscillator". The on-chip circuitry is not itself an oscillator, of course, but an amplifier that is suitable for use as the amplifier part of a feedback oscillator. The data sheets and Microcontroller Handbook show how the on-chip amplifier and several off-chip components can be used to design a working oscillator. With proper selection of off-chip components, these oscillator circuits will perform better than almost any other type of clock oscillator, and by almost any criterion of excellence. The suggested circuits are simple, economical, stable, and reliable.

We offer assistance to our customers in selecting suitable off-chip components to work with the on-chip oscillator circuitry. It should be noted, however, that Intel cannot assume the responsibility of writing specifications for the off-chip components of the complete oscillator circuit, nor of guaranteeing the performance of the finished design in production, anymore than a transistor manufacturer, whose data sheets show a number of suggested amplifier circuits, can assume responsibility for the operation, in production, of any of them.

We are often asked why we don't publish a list of required crystal or ceramic resonator specifications, and recommend values for the other off-chip components. This has been done in the past, but sometimes with consequences that were not intended.

Suppose we suggest a maximum crystal resistance of 30 ohms for some given frequency. Then your crystal supplier tells you the 30-ohm crystals are going to cost twice as much as 50-ohm crystals. Fearing that Intel will not "guarantee operation" with 50-ohm crystals, you order the expensive ones. In fact, Intel guarantees only what is embodied within an Intel product. Besides, there is no reason why 50-ohm crystals couldn't be used, if the other off-chip components are suitably adjusted.

Should we recommend values for the other off-chip components? Should we do it for 50-ohm crystals or 30-ohm crystals? With respect to what should we optimize their selection? Should we minimize start-up time or maximize frequency stability? In many applications, neither start-up time nor frequency stability are particularly critical, and our "recommendations" are only restricting your system to unnecessary tolerances. It all depends on the application.

Although we will neither "specify" nor "recommend" specific off-chip components, we do offer assistance in these tasks. Intel application engineers are available to provide whatever technical assistance may be needed or desired by our customers in designing with Intel products.

This Application Note is intended to provide such assistance in the design of oscillator circuits for microcontroller systems. Its purpose is to describe in a practical manner how oscillators work, how crystals and ceramic resonators work (and thus how to spec them), and what the on-chip amplifier looks like electronically and what its operating characteristics are. A BASIC program is provided in Appendix II to assist the designer in determining the effects of changing individual parameters. Suggestions are provided for establishing a pre-production test program.

FEEDBACK OSCILLATORS

Loop Gain

Figure 1 shows an amplifier whose output line goes into some passive network. If the input signal to the amplifier is v_1 , then the output signal from the amplifier is $v_2 = Av_1$ and the output signal from the passive network is $v_3 = \beta v_2 = \beta Av_1$. Thus βA is the overall gain from terminal 1 to terminal 3.

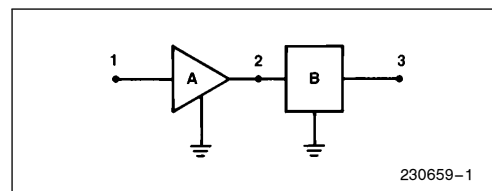

Figure 1. Factors in Loop Gain

Now connect terminal 1 to terminal 3, so that the signal path forms a loop: 1 to 2 to 3, which is also 1. Now we have a feedback loop, and the gain factor βA is called the *loop gain*.

Gain factors are complex numbers. That means they have a magnitude and a phase angle, both of which vary with frequency. When writing a complex number, one must specify both quantities, magnitude and angle. A number whose magnitude is 3, and whose angle is 45 degrees is commonly written this way: $3\angle 45^\circ$. The number 1 is, in complex number notation, $1\angle 0^\circ$, while -1 is $1\angle 180^\circ$.

By closing the feedback loop in Figure 1, we force the equality

$$v_1 = \beta Av_1$$

This equation has two solutions:

- 1) $v_1 = 0$;
- 2) $\beta A = 1\angle 0^\circ$.

In a given circuit, either or both of the solutions may be in effect. In the first solution the circuit is quiescent (no output signal). If you're trying to make an oscillator, a no-signal condition is unacceptable. There are ways to guarantee that the second solution is the one that will be in effect, and that the quiescent condition will be excluded.

How Feedback Oscillators Work

A feedback oscillator amplifies its own noise and feeds it back to itself in exactly the right phase, at the oscillation frequency, to build up and reinforce the desired oscillations. Its ability to do that depends on its loop gain. First, oscillations can occur only at the frequency for which the loop gain has a phase angle of 0 degrees. Second build-up of oscillations will occur only if the loop gain exceeds 1 at the frequency. Build-up continues until nonlinearities in the circuit reduce the average value of the loop gain to exactly 1.

Start-up characteristics depend on the small-signal properties of the circuit, specifically, the small-signal loop gain. Steady-state characteristics of the oscillator depend on the large-signal properties of the circuit, such as the transfer curve (output voltage vs. input voltage) of the amplifier, and the clamping effect of the input protection devices. These things will be discussed more fully further on. First we will look at the basic operation of the particular oscillator circuit, called the "positive reactance" oscillator.

The Positive Reactance Oscillator

Figure 2 shows the configuration of the positive reactance oscillator. The inverting amplifier, working into the impedance of the feedback network, produces an output signal that is nominally 180 degrees out of phase with its input. The feedback network must provide an additional 180 degrees phase shift, such that the overall loop gain has zero (or 360) degrees phase shift at the oscillation frequency.

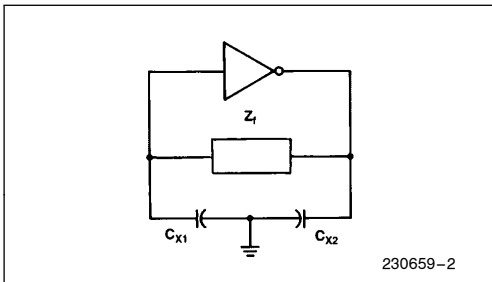

Figure 2. Positive Reactance Oscillator

In order for the loop gain to have zero phase angle it is necessary that the feedback element Z_f have a positive reactance. That is, it must be inductive. Then, the frequency at which the phase angle is zero is approximately the frequency at which

$$X_f = \frac{+1}{\omega C}$$

where X_f is the reactance of Z_f (the total Z_f being $R_f + jX_f$, and C is the series combination of C_{X1} and C_{X2}).

$$C = \frac{C_{X1} C_{X2}}{C_{X1} + C_{X2}}$$

In other words, Z_f and C form a parallel resonant circuit.

If Z_f is an inductor, then $X_f = \omega L$, and the frequency at which the loop gain has zero phase is the frequency at which

$$\omega L = \frac{1}{\omega C}$$

or

$$\omega = \frac{1}{\sqrt{LC}}$$

Normally, Z_f is not an inductor, but it must still have a positive reactance in order for the circuit to oscillate. There are some piezoelectric devices on the market that show a positive reactance, and provide a more stable oscillation frequency than an inductor will. Quartz crystals can be used where the oscillation frequency is critical, and lower cost ceramic resonators can be used where the frequency is less critical.

When the feedback element is a piezoelectric device, this circuit configuration is called a Pierce oscillator. The advantage of piezoelectric resonators lies in their property of providing a wide range of positive reactance values over a very narrow range of frequencies. The reactance will equal $1/\omega C$ at some frequency within this range, so the oscillation frequency will be within the same range. Typically, the width of this range is



only 0.3% of the nominal frequency of a quartz crystal, and about 3% of the nominal frequency of a ceramic resonator. With relatively little design effort, frequency accuracies of 0.03% or better can be obtained with quartz crystals, and 0.3% or better with ceramic resonators.

QUARTZ CRYSTALS

The crystal resonator is a thin slice of quartz sandwiched between two electrodes. Electrically, the device looks pretty much like a 5 or 6 pF capacitor, except that over certain ranges of frequencies the crystal has a positive (i.e., inductive) reactance.

The ranges of positive reactance originate in the piezoelectric property of quartz: Squeezing the crystal generates an internal E-field. The effect is reversible: Applying an AC E-field causes the crystal to vibrate. At certain vibrational frequencies there is a mechanical resonance. As the E-field frequency approaches a frequency of mechanical resonance, the measured reactance of the crystal becomes positive, as shown in Figure 3.

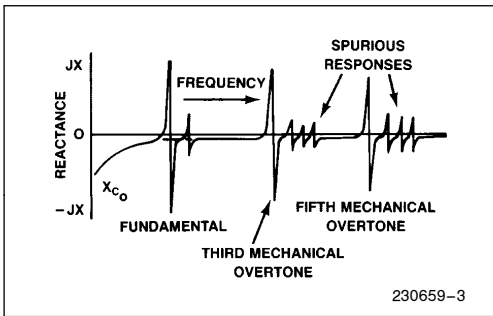

Figure 3. Crystal Reactance vs. Frequency

Typically there are several ranges of frequencies where in the reactance of the crystal is positive. Each range corresponds to a different mode of vibration in the crystal. The main resonances are the so-called fundamental response and the third and fifth overtone responses.

The overtone responses shouldn't be confused with the harmonics of the fundamental. They're not harmonics, but different vibrational modes. They're not in general at exact integer multiples of the fundamental frequency. There will also be "spurious" responses, occurring typically a few hundred KHz above each main response.

To assure that an oscillator starts in the desired mode on power-up, something must be done to suppress the loop gain in the undesired frequency ranges. The crystal itself provides some protection against unwanted modes of oscillation; too much resistance in that mode, for example. Additionally, junction capacitances in the amplifying devices tend to reduce the gain at higher frequencies, and thus may discriminate against unwanted modes. In some cases a circuit fix is necessary, such as inserting a trap, a phase shifter, or ferrite beads to kill oscillations in unwanted modes.

Crystal Parameters

Equivalent Circuit

Figure 4 shows an equivalent circuit that is used to represent the crystal for circuit analysis.

The R_1 - L_1 - C_1 branch is called the motivational arm of the crystal. The values of these parameters derive from the mechanical properties of the crystal and are constant for a given mode of vibration. Typical values for various nominal frequencies are shown in Table 1.

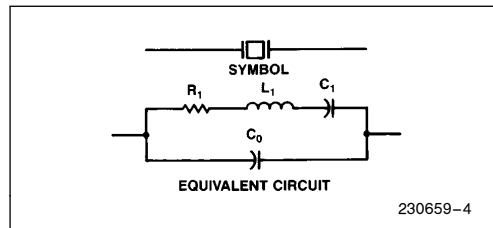

Figure 4. Quartz Crystal: Symbol and Equivalent Circuit

C_0 is called the shunt capacitance of the crystal. This is the capacitance of the crystal's electrodes and the mechanical holder. If one were to measure the reactance of the crystal at a frequency far removed from a resonance frequency, it is the reactance of this capacitance that would be measured. It's normally 3 to 7 pF.

Table 1. Typical Crystal Parameters

Frequency MHz	R_1 ohms	L_1 mH	C_1 pF	C_0 pF
2	100	520	0.012	4
4.608	36	117	0.010	2.9
11.25	19	8.38	0.024	5.4

The series resonant frequency of the crystal is the frequency at which L_1 and C_1 are in resonance. This frequency is given by

$$f_s = \frac{1}{2\pi\sqrt{L_1 C_1}}$$

At this frequency the impedance of the crystal is R_1 in parallel with the reactance of C_0 . For most purposes, this impedance is taken to be just R_1 , since the reactance of C_0 is so much larger than R_1 .

Load Capacitance

A crystal oscillator circuit such as the one shown in Figure 2 (redrawn in Figure 5) operates at the frequency for which the crystal is antiresonant (ie, parallel-resonant) with the total capacitance across the crystal terminals external to the crystal. This total capacitance external to the crystal is called the load capacitance.

As shown in Figure 5, the load capacitance is given by

$$C_L = \frac{C_{X1} C_{X2}}{C_{X1} + C_{X2}} + C_{stray}$$

The crystal manufacturer needs to know the value of C_L in order to adjust the crystal to the specified frequency.

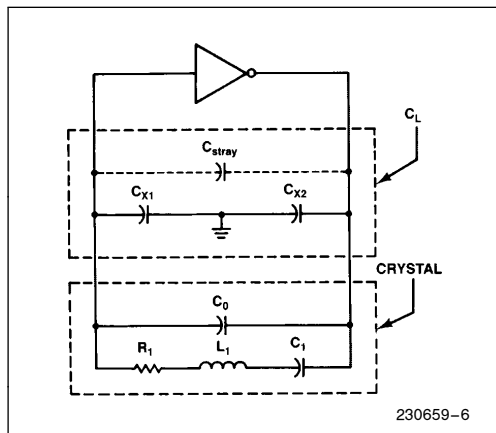

Figure 5. Load Capacitance

The adjustment involves putting the crystal in *series* with the specified C_L , and then “trimming” the crystal to obtain resonance of the series combination of the crystal and C_L at the specified frequency. Because of the high Q of the crystal, the resonant frequency of the series combination of the crystal and C_L is the same as

the antiresonant frequency of the *parallel* combination of the crystal and C_L . This frequency is given by

$$f_a = \frac{1}{2\pi\sqrt{L_1 C_1 (C_L + C_0)/(C_1 + C_L + C_0)}}$$

These frequency formulas are derived (in Appendix A) from the equivalent circuit of the crystal, using the assumptions that the Q of the crystal is extremely high, and that the circuit external to the crystal has no effect on the frequency other than to provide the load capacitance C_L . The latter assumption is not precisely true, but it is close enough for present purposes.

“Series” vs. “Parallel” Crystals

There is no such thing as a “series cut” crystal as opposed to a “parallel cut” crystal. There are different cuts of crystal, having to do with the parameters of its motional arm in various frequency ranges, but there is no special cut for series or parallel operation.

An oscillator is series resonant if the oscillation frequency is f_s of the crystal. To operate the crystal at f_s , the amplifier has to be noninverting. When buying a crystal for such an oscillator, one does not specify a load capacitance. Rather, one specifies the loading condition as “series.”

If a “series” crystal is put into an oscillator that has an inverting amplifier, it will oscillate in parallel resonance with the load capacitance presented to the crystal by the oscillator circuit, at a frequency slightly above f_s . In fact, at approximately

$$f_a = f_s \left(1 + \frac{C_1}{2(C_L + C_0)} \right)$$

This frequency would typically be about 0.02% above f_s .

Equivalent Series Resistance

The “series resistance” often listed on quartz crystal data sheets is the real part of the crystal impedance at the crystal’s calibration frequency. This will be R_1 if the calibration frequency is the series resonant frequency of the crystal. If the crystal is calibrated for parallel resonance with a load capacitance C_L , the equivalent series resistance will be

$$ESR = R_1 \left(1 + \frac{C_0}{C_L} \right)^2$$

The crystal manufacturer measures this resistance at the calibration frequency during the same operation in which the crystal is adjusted to the calibration frequency.



Frequency Tolerance

Frequency tolerance as discussed here is not a requirement on the crystal, but on the complete oscillator. There are two types of frequency tolerances on oscillators: frequency *accuracy* and frequency *stability*. Frequency accuracy refers to the oscillator's ability to run at an exact specified frequency. Frequency stability refers to the constancy of the oscillation frequency.

Frequency accuracy requires mainly that the oscillator circuit present to the crystal the same load capacitance that it was adjusted for. Frequency stability requires mainly that the load capacitance be constant.

In most digital applications the accuracy and stability requirements on the oscillator are so wide that it makes very little difference what load capacitance the crystal was adjusted to, or what load capacitance the circuit actually presents to the crystal. For example, if a crystal was calibrated to a load capacitance of 25 pF, and is used in a circuit whose actual load capacitance is 50 pF, the frequency error on that account would be less than 0.01%.

In a positive reactance oscillator, the crystal only needs to be in the intended response mode for the oscillator to satisfy a 0.5% or better frequency tolerance. That's because for any load capacitance the oscillation frequency is certain to be between the crystal's resonant and anti-resonant frequencies.

Phase shifts that take place within the amplifier part of the oscillator will also affect frequency accuracy and stability. These phase shifts can normally be modeled as an "output capacitance" that, in the positive reactance oscillator, parallels C_{X2} . The predictability and constancy of this output capacitance over temperature and device sample will be the limiting factor in determining the tolerances that the circuit is capable of holding.

Drive Level

Drive level refers to the power dissipation in the crystal. There are two reasons for specifying it. One is that the parameters in the equivalent circuit are somewhat dependent on the drive level at which the crystal is calibrated. The other is that if the application circuit exceeds the test drive level by too much, the crystal may be damaged. Note that the terms "test drive level" and "rated drive level" both refer to the drive level at which the crystal is calibrated. Normally, in a microcontroller system, neither the frequency tolerances nor the power levels justify much concern for this specification. Some crystal manufacturers don't even require it for microprocessor crystals.

In a positive reactance oscillator, if one assumes the peak voltage across the crystal to be something in the neighborhood of V_{CC} , the power dissipation can be approximated as

$$P = 2R_1 [\pi f (C_L + C_0) V_{CC}]^2$$

This formula is derived in Appendix A. In a 5V system, P rarely evaluates to more than a milliwatt. Crystals with a standard 1 or 2 mW drive level rating can be used in most digital systems.

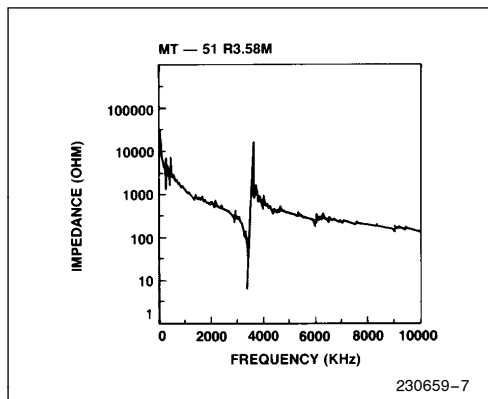

Figure 6. Ceramic Resonator Impedance vs. Frequency (Test Data Supplied by NTK Technical Ceramics)

CERAMIC RESONATORS

Ceramic resonators operate on the same basic principles as a quartz crystal. Like quartz crystals, they are piezoelectric, have a reactance versus frequency curve similar to a crystal's, and an equivalent circuit that looks just like a crystal's (with different parameter values, however).

The frequency tolerance of a ceramic resonator is about two orders of magnitude wider than a crystal's, but the ceramic is somewhat cheaper than a crystal. It may be noted for comparison that quartz crystals with relaxed tolerances cost about twice as much as ceramic resonators. For purposes of clocking a microcontroller, the frequency tolerance is often relatively noncritical, and the economic consideration becomes the dominant factor.

Figure 6 shows a graph of impedance magnitude versus frequency for a 3.58 MHz ceramic resonator. (Note that Figure 6 is a graph of $|Z_f|$ versus frequency, where

as Figure 3 is a graph of X_f versus frequency.) A number of spurious responses are apparent in Figure 6. The manufacturers state that spurious responses are more prevalent in the lower frequency resonators (kHz range) than in the higher frequency units (MHz range). For our purposes only the MHz range ceramics need to be considered.

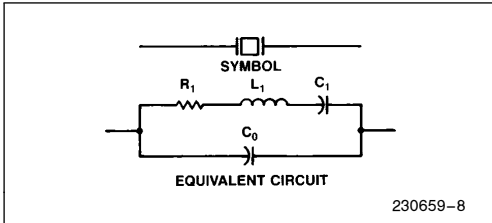

Figure 7. Ceramic Resonator: Symbol and Equivalent Circuit

Figure 7 shows the symbol and equivalent circuit for the ceramic resonator, both of which are the same as for the crystal. The parameters have different values, however, as listed in Table 2.

Table 2. Typical Ceramic Parameters

Frequency MHz	R ₁ ohms	L ₁ mH	C ₁ pF	C ₀ pF
3.58	7	0.113	19.6	140
6.0	8	0.094	8.3	60
8.0	7	0.092	4.6	40
11.0	10	0.057	3.9	30

Note that the motional arm of the ceramic resonator tends to have less resistance than the quartz crystal and also a vastly reduced L_1/C_1 ratio. This results in the motional arm having a Q (given by $(1/R_1) \sqrt{L_1/C_1}$) that is typically two orders of magnitude lower than that of a quartz crystal. The lower Q makes for a faster startup of the oscillator and for a less closely controlled frequency (meaning that circuitry external to the resonator will have more influence on the frequency than with a quartz crystal).

Another major difference is that the shunt capacitance of the ceramic resonator is an order of magnitude higher than C_0 of the quartz crystal and more dependent on the frequency of the resonator.

The implications of these differences are not all obvious, but some will be indicated in the section on Oscillator Calculations.

Specifications for Ceramic Resonators

Ceramic resonators are easier to specify than quartz crystals. All the vendor wants to know is the desired

frequency and the chip you want it to work with. They'll supply the resonators, a circuit diagram showing the positions and values of other external components that may be required and a guarantee that the circuit will work properly at the specified frequency.

OSCILLATOR DESIGN CONSIDERATIONS

Designers of microcontroller systems have a number of options to choose from for clocking the system. The main decision is whether to use the "on-chip" oscillator or an external oscillator. If the choice is to use the on-chip oscillator, what kinds of external components are needed to make it operate as advertised? If the choice is to use an external oscillator, what type of oscillator should it be?

The decisions have to be based on both economic and technical requirements. In this section we'll discuss some of the factors that should be considered.

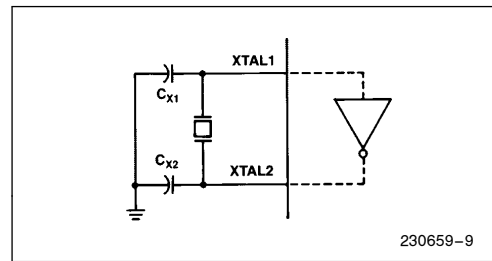

Figure 8. Using the "On-Chip" Oscillator

On-Chip Oscillators

In most cases, the on-chip amplifier with the appropriate external components provides the most economical solution to the clocking problem. Exceptions may arise in severe environments when frequency tolerances are tighter than about 0.01%.

The external components that need to be added are a positive reactance (normally a crystal or ceramic resonator) and the two capacitors C_{X1} and C_{X2} , as shown in Figure 8.

Crystal Specifications

Specifications for an appropriate crystal are not very critical, unless the frequency is. Any fundamental-mode crystal of medium or better quality can be used.

We are often asked what maximum crystal resistance should be specified. The best answer to this question is the lower the better, but use what's available. The crystal resistance will have some effect on start-up time and steady-state amplitude, but not so much that it can't be compensated for by appropriate selection of the capacitances C_{X1} and C_{X2} .

Similar questions are asked about specifications of load capacitance and shunt capacitance. The best advice we can give is to understand what these parameters mean and how they affect the operation of the circuit (that being the purpose of this Application Note), and then decide for yourself if such specifications are meaningful in your application or not. Normally, they're not, unless your frequency tolerances are tighter than about 0.1%.

Part of the problem is that crystal manufacturers are accustomed to talking "ppm" tolerances with radio engineers and simply won't take your order until you've filled out their list of specifications. It will help if you define your actual frequency tolerance requirements, both for yourself and to the crystal manufacturer. Don't pay for 0.003% crystals if your actual frequency tolerance is 1%.

Oscillation Frequency

The oscillation frequency is determined 99.5% by the crystal and up to about 0.5% by the circuit external to the crystal. The on-chip amplifier has little effect on the frequency, which is as it should be, since the amplifier parameters are temperature and process dependent.

The influence of the on-chip amplifier on the frequency is by means of its input and output (pin-to-ground) capacitances, which parallel C_{X1} and C_{X2} , and the XTAL1-to-XTAL2 (pin-to-pin) capacitance, which parallels the crystal. The input and pin-to-pin capacitances are about 7 pF each. Internal phase deviations from the nominal 180° can be modeled as an output capacitance of 25 to 30 pF. These deviations from the ideal have less effect in the positive reactance oscillator (with the inverting amplifier) than in a comparable series resonant oscillator (with the noninverting amplifier) for two reasons: first, the effect of the output capacitance is lessened, if not swamped, by the off-chip capacitor; secondly, the positive reactance oscillator is less sensitive, frequency-wise, to such phase errors.

Selection of C_{X1} and C_{X2}

Optimal values for the capacitors C_{X1} and C_{X2} depend on whether a quartz crystal or ceramic resona-

tor is being used, and also on application-specific requirements on start-up time and frequency tolerance.

Start-up time is sometimes more critical in microcontroller systems than frequency stability, because of various reset and initialization requirements.

Less commonly, accuracy of the oscillator frequency is also critical, for example, when the oscillator is being used as a time base. As a general rule, fast start-up and stable frequency tend to pull the oscillator design in opposite directions.

Considerations of both start-up time and frequency stability over temperature suggest that C_{X1} and C_{X2} should be about equal and at least 20 pF. (But they don't *have* to be either.) Increasing the value of these capacitances above some 40 or 50 pF improves frequency stability. It also tends to increase the start-up time. There is a maximum value (several hundred pF, depending on the value of R_1 of the quartz or ceramic resonator) above which the oscillator won't start up at all.

If the on-chip amplifier is a simple inverter, such as in the 8051, the user can select values for C_{X1} and C_{X2} between some 20 and 100 pF, depending on whether start-up time or frequency stability is the more critical parameter in a specific application. If the on-chip amplifier is a Schmitt Trigger, such as in the 8048, smaller values of C_{X1} must be used (5 to 30 pF), in order to prevent the oscillator from running in a relaxation mode.

Later sections in this Application Note will discuss the effects of varying C_{X1} and C_{X2} (as well as other parameters), and will have more to say on their selection.

Placement of Components

Noise glitches arriving at XTAL1 or XTAL2 pins at the wrong time can cause a miscount in the internal clock-generating circuitry. These kinds of glitches can be produced through capacitive coupling between the oscillator components and PCB traces carrying digital signals with fast rise and fall times. For this reason, the oscillator components should be mounted close to the chip and have short, direct traces to the XTAL1, XTAL2, and VSS pins.

Clocking Other Chips

There are times when it would be desirable to use the on-chip oscillator to clock other chips in the system.

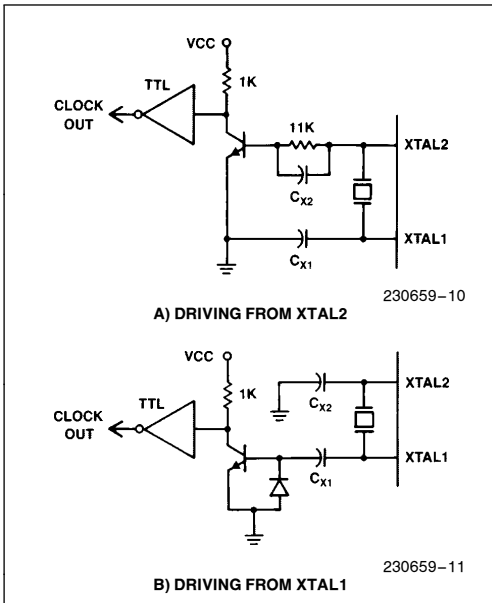

Figure 9. Using the On-Chip Oscillator to Drive Other Chips

This can be done if an appropriate buffer is used. A TTL buffer puts too much load on the on-chip amplifier for reliable start-up. A CMOS buffer (such as the 74HC04) can be used, if it's fast enough and if its V_{IH} and V_{IL} specs are compatible with the available signal amplitudes. Circuits such as shown in Figure 9 might also be considered for these types of applications.

Clock-related signals are available at the TO pin in the MCS-48 products, at ALE in the MCS-48 and MCS-51 lines, and the iACX-96 controllers provide a CLKOUT signal.

External Oscillators

When technical requirements dictate the use of an external oscillator, the external drive requirements for the microcontroller, as published in the data sheet, must be carefully noted. The logic levels are not in general TTL-compatible. And each controller has its idiosyncracies in this regard. The 8048, for example, requires that both XTAL1 and XTAL2 be driven. The 8051 *can* be driven that way, but the data sheet suggest the simpler method of grounding XTAL1 and driving XTAL2. For this method, the driving source must be capable of sinking some current when XTAL2 is being driven low.

For the external oscillator itself, there are basically two choices: ready-made and home-grown.



TTL Crystal Clock Oscillator

The HS-100, HS-200, & HS-500 all-metal package series of oscillators are TTL compatible & fit a DIP layout. Standard electrical specifications are shown below. Variations are available for special applications.

Frequency Range: HS-100—3.5 MHz to 30 MHz
 HS-200—225 KHz to 3.5 MHz
 HS-500—25 MHz to 60 MHz

Frequency Tolerance: ±0.1% Overall 0°C–70°C

Hermetically Sealed Package

Mass spectrometer leak rate max.
 1×10^{-8} atmos. cc/sec. of helium

Output Waveform

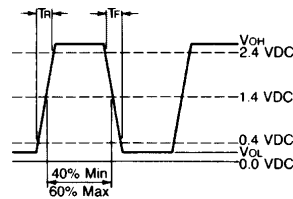

230659-12

INPUT				
	HS-100		HS-200	HS-500
	3.5 MHz–20 MHz	20 + MHz–30 MHz	225 KHz–4.0 MHz	25 MHz–60 MHz
Supply Voltage (V _{CC})	5V ± 10%	5V ± 10%	5V ± 10%	5V ± 10%
Supply Current (I _{CC}) max.	30 mA	40 mA	85 mA	50 mA
OUTPUT				
	HS-100		HS-200	HS-500
	3.5 MHz–20 MHz	20 + MHz–30 MHz	225 KHz–4.0 MHz	25 MHz–60 MHz
V _{OH} (Logic “1”)	+2.4V min. ¹	+2.7V min. ²	+2.4V min. ¹	+2.7V min. ²
V _{OL} (Logic “0”)	+0.4V max. ³	+0.5V max. ⁴	+0.4V max. ³	+0.5V max. ⁴
Symmetry	60/40% ⁵	60/40% ⁵	55/45% ⁵	60/40% ⁵
T _R , T _F (Rise & Fall Time)	< 10 ns ⁶	< 5 ns ⁶	< 15 ns ⁶	< 5 ns ⁶
Output Short Circuit Current	18 mA min.	40 mA min.	18 mA min.	40 mA min.
Output Load	1 to 10 TTL Loads ⁷	1 to 10 TTL Loads ⁸	1 to 10 TTL Loads ⁷	1 to 10 TTL Loads ⁸
CONDITIONS				
	¹ I _O source = –400 μA max.	⁴ I _O sink = 20.00 mA max.	⁷ 1.6 mA per load	
	² I _O source = –1.0 mA max.	⁵ V _O = 1.4V	⁸ 82.0 mA per load	
	³ I _O sink = 16.0 mA max.	⁶ (0.4V to 2.4V)		

Figure 10. Pre-Packaged Oscillator Data*

*Reprinted with the permission of ©Midland-Ross Corporation 1982.

Prepackaged oscillators are available from most crystal manufacturers, and have the advantage that the system designer can treat the oscillator as a black box whose performance is guaranteed by people who carry many years of experience in designing and building oscillators. Figure 10 shows a typical data sheet for some prepackaged oscillators. Oscillators are also available with complementary outputs.

If the oscillator is to drive the microcontroller directly, one will want to make a careful comparison between the external drive requirements in the microcontroller data sheet and the oscillator's output logic levels and test conditions.

If oscillator stability is less critical than cost, the user may prefer to go with an in-house design. Not without some precautions, however.

It's easy to design oscillators that work. Almost all of them do work, even if the designer isn't too clear on why. The key point here is that *almost* all of them work. The problems begin when the system goes into production, and marginal units commence malfunctioning in the field. Most digital designers, after all, are not very adept at designing oscillators *for production*.

Oscillator design is somewhat of a black art, with the quality of the finished product being *very* dependent on the designer's experience and intuition. For that reason the most important consideration in any design is to have an adequate preproduction test program. Preproduction tests are discussed later in this Application Note. Here we will discuss some of the design options and take a look at some commonly used configurations.

Gate Oscillators versus Discrete Devices

Digital systems designers are understandably reluctant to get involved with discrete devices and their peculiarities (biasing techniques, etc.). Besides, the component count for these circuits tends to be quite a bit higher than what a digital designer is used to seeing for that amount of functionality. Nevertheless, if there are unusual requirements on the accuracy and stability of the clock frequency, it should be noted that discrete device oscillators can be tailored to suit the exact needs of the application and perfected to a level that would be difficult for a gate oscillator to approach.

In most cases, when an external oscillator is needed, the designer tends to rely on some form of a gate oscillator. A TTL inverter with a resistor connecting the output to the input makes a suitable inverting amplifier. The resistor holds the inverter in the transition region between logical high and low, so that at least for start-up purposes the inverter is a linear amplifier.

The feedback resistance has to be quite low, however, since it must conduct current sourced by the input pin without allowing the DC input voltage to get too far above the DC output voltage. For biasing purposes, the feedback resistance should not exceed a few k-ohms. But shunting the crystal with such a low resistance does not encourage start-up.

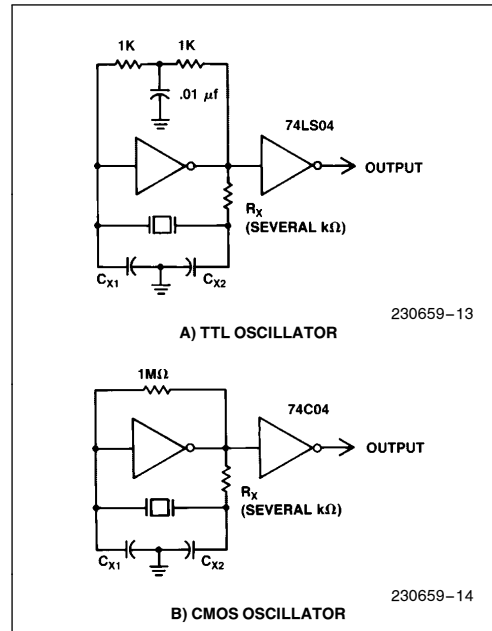

Figure 11. Commonly Used Gate Oscillators

Consequently, the configuration in Figure 11A might be suggested. By breaking R_f into two parts and AC-grounding the midpoint, one achieves the DC feedback required to hold the inverter in its active region, but without the negative signal feedback that is in effect telling the circuit *not* to oscillate. However, this biasing scheme will increase the start-up time, and relaxation-type oscillations are also possible.

A CMOS inverter, such as the 74HC04, might work better in this application, since a larger R_f can be used to hold the inverter in its linear region.

Logic gates tend to have a fairly low output resistance, which destabilizes the oscillator. For that reason a resistor R_x is often added to the feedback network, as shown in Figures 11A and B. At higher frequencies a 20 or 30 pF capacitor is sometimes used in the R_x position, to compensate for some of the internal propagation delay.

Reference 1 contains an excellent discussion of gate oscillators, and a number of design examples.

Fundamental versus Overtone Operation

It's easier to design an oscillator circuit to operate in the resonator's fundamental response mode than to design one for overtone operation. A quartz crystal whose fundamental response mode covers the desired frequency can be obtained up to some 30 MHz. For frequencies above that, the crystal might be used in an overtone mode.

Several problems arise in the design of an overtone oscillator. One is to stop the circuit from oscillating in the fundamental mode, which is what it would really rather do, for a number of reasons, involving both the amplifying device and the crystal. An additional problem with overtone operation is an increased tendency to spurious oscillations. That is because the R_1 of various spurious modes is likely to be about the same as R_1 of the intended overtone response. It may be necessary, as suggested in Reference 1, to specify a "spurious-to-main-response" resistance ratio to avoid the possibility of trouble.

Overtone oscillators are not to be taken lightly. One would be well advised to consult with an engineer who is knowledgeable in the subject during the design phase of such a circuit.

Series versus Parallel Operation

Series resonant oscillators use noninverting amplifiers. To make a noninverting amplifier out of logic gates requires that two inverters be used, as shown in Figure 12.

This type of circuit tends to be inaccurate and unstable in frequency over variations in temperature and V_{CC} . It has a tendency to oscillate at overtones, and to oscillate through C_0 of the crystal or some stray capacitance rather than as controlled by the mechanical resonance of the crystal.

The demon in series resonant oscillators is the phase shift in the amplifier. The series resonant oscillator wants more than just a "noninverting" amplifier—it wants a *zero phase-shift* amplifier. Multistage noninverting amplifiers tend to have a considerably lagging phase shift, such that the crystal reactance must be capacitive in order to bring the total phase shift around the feedback loop back up to 0. In this mode, a "12 MHz" crystal may be running at 8 or 9 MHz. One can put a capacitor in series with the crystal to relieve the crystal of having to produce all of the required phase shift, and bring the oscillation frequency closer to f_s . However, to further complicate the situation, the amplifier's phase shift is strongly dependent on frequency, temperature, V_{CC} , and device sample.

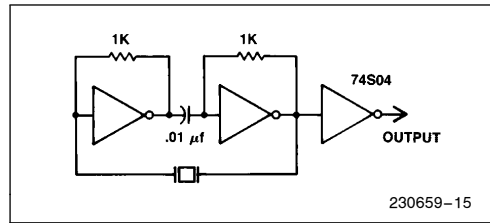

Figure 12. "Series Resonant" Gate Oscillator

Positive reactance oscillators ("parallel resonant") use inverting amplifiers. A single logic inverter can be used for the amplifier, as in Figure 11. The amplifier's phase shift is less critical, compared to a series resonant circuit, and since only one inverter is involved there's less phase error anyway. The oscillation frequency is effectively bounded by the resonant and antiresonant frequencies of the crystal itself. In addition, the feedback network includes capacitors that parallel the input and output terminals of the amplifier, thus reducing the effect of unpredictable capacitances at these points.

MORE ABOUT USING THE "ON-CHIP" OSCILLATORS

In this section we will describe the on-chip inverters on selected microcontrollers in some detail, and discuss criteria for selecting components to work with them. Future data sheets will supplement this discussion with updates and information pertinent to the use of each chip's oscillator circuitry.

Oscillator Calculations

Oscillator design, though aided by theory, is still largely an empirical exercise. The circuit is inherently nonlinear, and the normal analysis parameters vary with instantaneous voltage. In addition, when dealing with the on-chip circuitry, we have FETs being used as resistors, resistors being used as interconnects, distributed delays, input protection devices, parasitic junctions, and processing variations.

Consequently, oscillator calculations are never very precise. They can be useful, however, if they will at least indicate the effects of *variations* in the circuit parameters on start-up time, oscillation frequency, and steady-state amplitude. Start-up time, for example, can be taken as an indication of start-up reliability. If pre-production tests indicate a possible start-up problem, a relatively inexperienced designer can at least be made aware of what parameter may be causing the marginality, and what direction to go in to fix it.

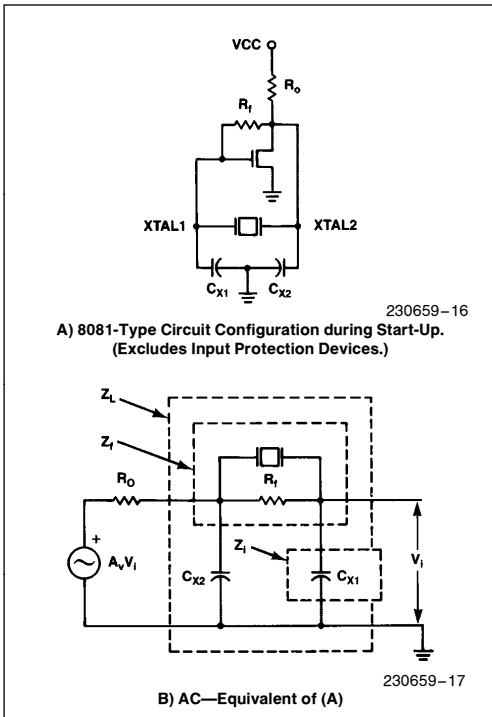

Figure 13. Oscillator Circuit Model Used in Start-Up Calculations

The analysis used here is mathematically straightforward but algebraically intractable. That means it's relatively easy to understand and program into a computer, but it will not yield a neat formula that gives, say, steady-state amplitude as a function of this or that list of parameters. A listing of a BASIC program that implements the analysis will be found in Appendix II.

When the circuit is first powered up, and before the oscillations have commenced (and if the oscillations *fail* to commence), the oscillator can be treated as a small signal linear amplifier with feedback. In that case, standard small-signal analysis techniques can be used to determine start-up characteristics. The circuit model used in this analysis is shown in Figure 13.

The circuit approximates that there are no high-frequency effects within the amplifier itself, such that its high-frequency behavior is dominated by the load impedance Z_L . This is a reasonable approximation for single-stage amplifiers of the type used in 8051-type devices. Then the gain of the amplifier as a function of frequency is

$$A = \frac{A_v Z_L}{Z_L + R_0}$$

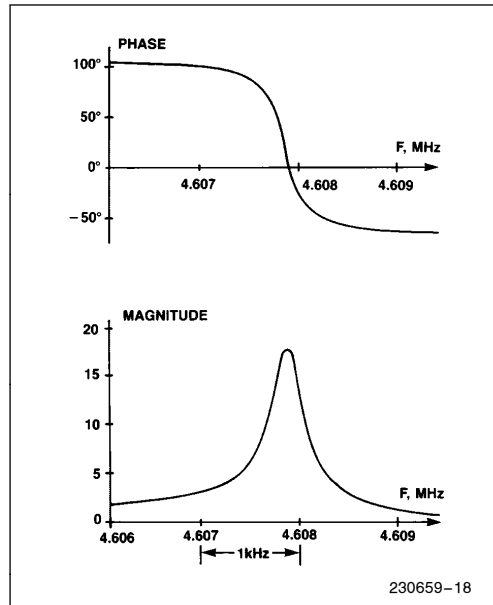

Figure 14. Loop Gain versus Frequency (4.608 MHz Crystal)

The gain of the feedback network is

$$\beta = \frac{Z_i}{Z_i + Z_f}$$

And the loop gain is

$$\beta A = \frac{Z_i}{Z_i + Z_f} \times \frac{A_v Z_L}{Z_L + R_0}$$

The impedances Z_L , Z_f , and Z_i are defined in Figure 13B.

Figure 14 shows the way the loop gain thus calculated (using typical 8051-type parameters and a 4.608 MHz crystal) varies with frequency. The frequency of interest is the one for which the phase of the loop gain is zero. The accepted criterion for start-up is that the magnitude of the loop gain must exceed unity at this frequency. This is the frequency at which the circuit is in resonance. It corresponds very closely with the antiresonant frequency of the motional arm of the crystal in parallel with C_L .

Figure 15 shows the way the loop gain varies with frequency when the parameters of a 3.58 MHz ceramic resonator are used in place of a crystal (the amplifier parameters being typical 8051, as in Figure 14). Note the different frequency scales.

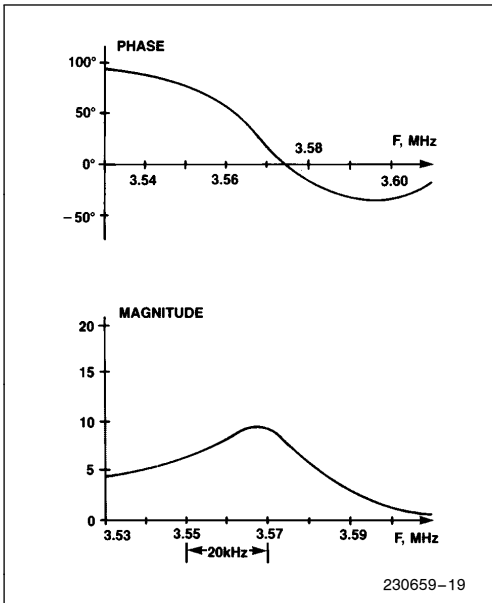

Figure 15. Loop Gain versus Frequency (3.58 MHz Ceramic)

Start-Up Characteristics

It is common, in studies of feedback systems, to examine the behavior of the closed loop gain as a function of complex frequency $s = \sigma + j\omega$; specifically, to determine the location of its poles in the complex plane. A pole is a point on the complex plane where the gain function goes to infinity. Knowledge of its location can be used to predict the response of the system to an input disturbance.

The way that the response function depends on the location of the poles is shown in Figure 16. Poles in the left-half plane cause the response function to take the form of a damped sinusoid. Poles in the right-half plane cause the response function to take the form of an exponentially growing sinusoid. In general,

$$v(t) \sim e^{at} \sin(\omega t + \theta)$$

where a is the real part of the pole frequency. Thus if the pole is in the right-half plane, a is positive and the sinusoid grows. If the pole is in the left-half plane, a is negative and the sinusoid is damped.

The same type of analysis can usefully be applied to oscillators. In this case, however, rather than trying to ensure that the poles are in the left-half plane, we would seek to ensure that they're in the *right*-half plane. An exponentially growing sinusoid is exactly what is wanted from an oscillator that has just been powered up.

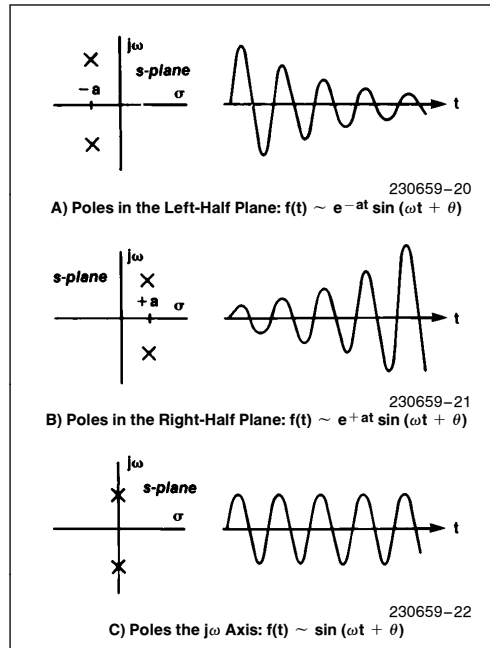

Figure 16. Do You Know Where Your Poles Are Tonight?

The gain function of interest in oscillators is $1/(1 - \beta A)$. Its poles are at the complex frequencies where $\beta A = 1 \angle 0^\circ$, because that value of βA causes the gain function to go to infinity. The oscillator will start up if the real part of the pole frequency is positive. More importantly, the *rate* at which it starts up is indicated by how *much* greater than 0 the real part of the pole frequency is.

The circuit in Figure 13B can be used to find the pole frequencies of the oscillator gain function. All that needs to be done is evaluate the impedances at complex frequencies $\sigma + j\omega$ rather than just at ω , and find the value of $\sigma + j\omega$ for which $\beta A = 1 \angle 0^\circ$. The larger that value of σ is, the faster the oscillator will start up.

Of course, other things besides pole frequencies, things like the VCC rise time, are at work in determining the start-up time. But to the extent that the pole frequencies *do* affect start-up time, we can obtain results like those in Figures 17 and 18.

To obtain these figures the pole frequencies were computed for various values of capacitance C_X from XTAL1 and XTAL2 to ground (thus $C_{X1} = C_{X2} = C_X$). Then a "time constant" for start-up was calculated as $T_s = \frac{1}{\sigma}$ where σ is the real part of the pole frequency (rad/sec), and this time constant is plotted versus C_X .

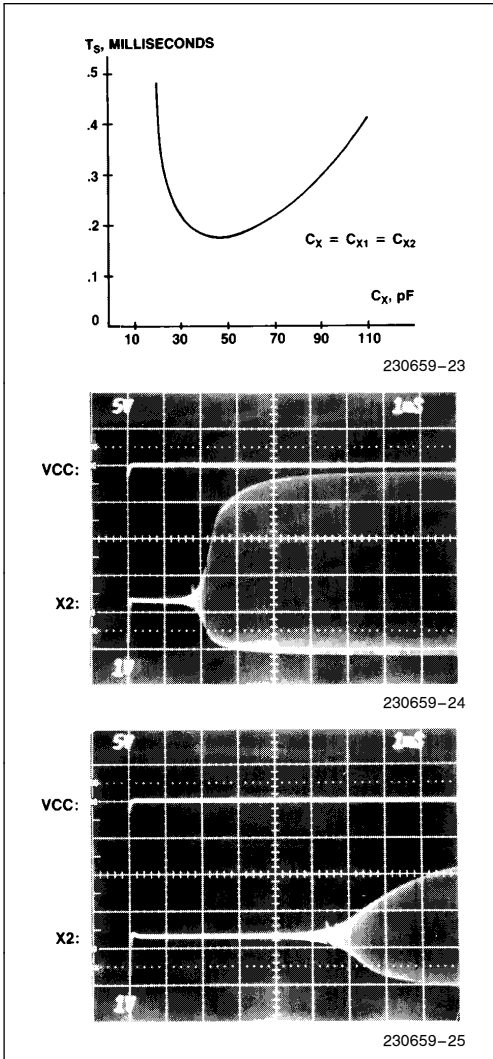

Figure 17. Oscillator Start-Up (4.608 MHz Crystal from Standard Crystal Corp.)

A short time constant means faster start-up. A long time constant means slow start-up. Observations of actual start-ups are shown in the figures. Figure 17 is for a typical 8051 with a 4.608 MHz crystal supplied by Standard Crystal Corp., and Figure 18 is for a typical 8051 with a 3.58 MHz ceramic resonator supplied by NTK Technical Ceramics, Ltd.

It can be seen in Figure 17 that, for this crystal, values of C_x between 30 and 50 pF minimize start-up time, but that the exact value in this range is not particularly important, even if the start-up time itself is critical.

As previously mentioned, start-up time can be taken as an indication of start-up reliability. Start-up problems are normally associated with C_{X1} and C_{X2} being too small or too large for a given resonator. If the parameters of the resonator are known, curves such as in Figure 17 or 18 can be generated to define acceptable ranges of values for these capacitors.

As the oscillations grow in amplitude, they reach a level at which they undergo severe clipping within the amplifier, in effect reducing the amplifier gain. As the amplifier gain decreases, the poles move towards the $j\omega$ axis. In steady-state, the poles are on the $j\omega$ axis and the amplitude of the oscillations is constant.

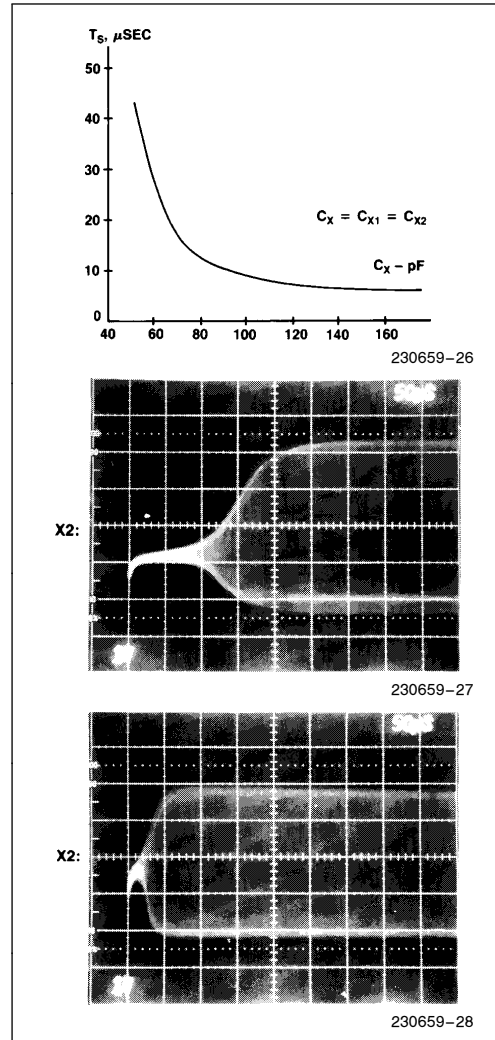

Figure 18. Oscillator Start-Up (3.58 MHz Ceramic Resonator from NTK Technical Ceramics)

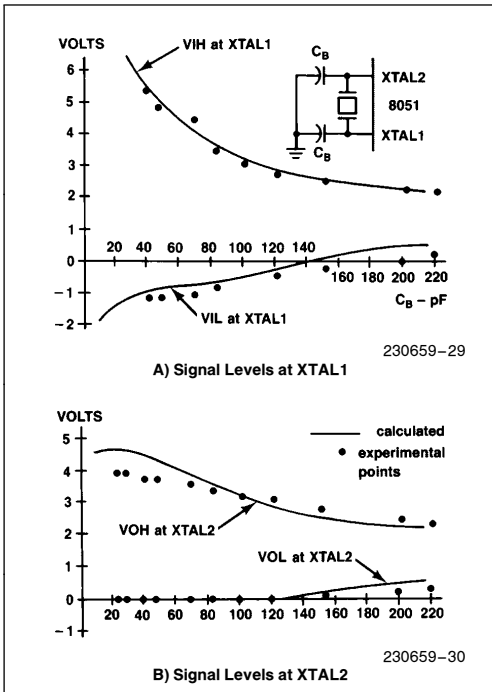

Figure 19. Calculated and Experimental Steady-State Amplitudes vs. Bulk Capacitance from XTAL1 and XTAL2 to Ground

Steady-State Characteristics

Steady-state analysis is greatly complicated by the fact that we are dealing with large signals and nonlinear circuit response. The circuit parameters vary with instantaneous voltage, and a number of clamping and clipping mechanisms come into play. Analyses that take all these things into account are too complicated to be of general use, and analyses that don't take them into account are too inaccurate to justify the effort.

There is a steady-state analysis in Appendix B that takes some of the complications into account and ignores others. Figure 19 shows the way the steady-state amplitudes thus calculated (using typical 8051 parameters and a 4.608 MHz crystal) vary with equal bulk capacitance placed from XTAL1 and XTAL2 to ground. Experimental results are shown for comparison.

The waveform at XTAL1 is a fairly clean sinusoid. Its negative peak is normally somewhat below zero, at a level which is determined mainly by the input protection circuitry at XTAL1.

The input protection circuitry consists of an ohmic resistor and an enhancement-mode FET with the gate

and source connected to ground (VSS), as shown in Figure 20 for the 8051, and in Figure 21 for the 8048. Its function is to limit the positive voltage at the gate of the input FET to the avalanche voltage of the drain junction. If the input pin is driven below VSS, the drain and source of the protection FET interchange roles, so its gate is connected to what is now the drain. In this condition the device resembles a diode with the anode connected to VSS.

There is a parasitic pn junction between the ohmic resistor and the substrate. In the ROM parts (8015, 8048, etc.) the substrate is held at approximately $-3V$ by the on-chip back-bias generator. In the EPROM parts (8751, 8748, etc.) the substrate is connected to VSS.

The effect of the input protection circuitry on the oscillator is that if the XTAL1 signal goes negative, its negative peak is clamped to $-V_{DS}$ of the protection FET in the ROM parts, and to about $-0.5V$ in the EPROM parts. These negative voltages on XTAL1 are in this application self-limiting and nondestructive.

The clamping action does, however, raise the DC level at XTAL1, which in turn tends to reduce the positive peak at XTAL2. The waveform at XTAL2 resembles a sinusoid riding on a DC level, and whose negative peaks are clipped off at zero.

Since it's normally the XTAL2 signal that drives the internal clocking circuitry, the question naturally arises as to how large this signal must be to reliably do its job. In fact, the XTAL2 signal doesn't have to meet the same VIH and VIL specifications that an external driver would have to. That's because as long as the oscillator is working, the on-chip amplifier is driving itself through its own 0-to-1 transition region, which is very nearly the same as the 0-to-1 transition region in the internal buffer that follows the oscillator. If some processing variations move the transition level higher or lower, the on-chip amplifier tends to compensate for it by the fact that its own transition level is correspondingly higher or lower. (In the 8096, it's the XTAL1 signal that drives the internal clocking circuitry, but the same concept applies.)

The main concern about the XTAL2 signal amplitude is an indication of the general health of the oscillator. An amplitude of less than about 2.5V peak-to-peak indicates that start-up problems could develop in some units (with low gain) with some crystals (with high R_1). The remedy is to either adjust the values of C_{X1} and/or C_{X2} or use a crystal with a lower R_1 .

The amplitudes at XTAL1 and XTAL2 can be adjusted by changing the ratio of the capacitors from XTAL1 and XTAL2 to ground. Increasing the XTAL2 capacitance, for example, decreases the amplitude at XTAL2 and increases the amplitude at XTAL1 by about the same amount. Decreasing both caps increases both amplitudes.

Pin Capacitance

Internal pin-to-ground and pin-to-pin capacitances at XTAL1 and XTAL2 will have some effect on the oscillator. These capacitances are normally taken to be in the range of 5 to 10 pF, but they are extremely difficult to evaluate. Any measurement of one such capacitance will necessarily include effects from the others. One advantage of the positive reactance oscillator is that the pin-to-ground capacitances are paralleled by external bulk capacitors, so a precise determination of their value is unnecessary. We would suggest that there is little justification for more precision than to assign them a value of 7 pF (XTAL1-to-ground and XTAL1-to-XTAL2). This value is probably not in error by more than 3 or 4 pF.

The XTAL2-to-ground capacitance is not entirely “pin capacitance,” but more like an “equivalent output capacitance” of some 25 to 30 pF, having to include the effect of internal phase delays. This value will vary to some extent with temperature, processing, and frequency.

MCS®-51 Oscillator

The on-chip amplifier on the HMOS MCS-51 family is shown in Figure 20. The drain load and feedback “resistors” are seen to be field-effect transistors. The drain load FET, R_D , is typically equivalent to about 1K to 3 K-ohms. As an amplifier, the low frequency voltage gain is normally between -10 and -20, and the output resistance is effectively R_D .

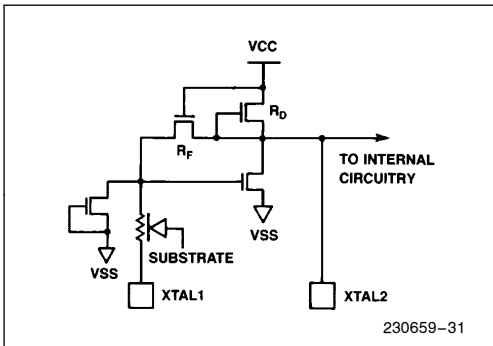

Figure 20. MCS®-51 Oscillator Amplifier

The 80151 oscillator is normally used with equal bulk capacitors placed externally from XTAL1 to ground and from XTAL2 to ground. To determine a reasonable value of capacitance to use in these positions, given a crystal of ceramic resonator of known parameters, one can use the BASIC analysis in Appendix II to generate curves such as in Figures 17 and 18. This procedure will define a range of values that will minimize start-up time. We don't suggest that smaller values be

used than those which minimize start-up time. Larger values than those can be used in applications where increased frequency stability is desired, at some sacrifice in start-up time.

Standard Crystal Corp. (Reference 8) studied the use of their crystals with the MCS-51 family using skew sample supplied by Intel. They suggest putting 30 pF capacitors from XTAL1 and XTAL2 to ground, if the crystal is specified as described in Reference 8. They noted that in that configuration and with crystals thus specified, the frequency accuracy was $\pm 0.01\%$ and the frequency stability was $\pm 0.005\%$, and that a frequency accuracy of $\pm 0.005\%$ could be obtained by substituting a 25 pF fixed cap in parallel with a 5-20 pF trimmer for one of the 30 pF caps.

MCS-51 skew samples have also been supplied to a number of ceramic resonator manufacturers for characterization with their products. These companies should be contacted for application information on their products. In general, however, ceramics tend to want somewhat larger values for C_{X1} and C_{X2} than quartz crystals do. As shown in Figure 18, they start up a lot faster that way.

In some application the actual frequency tolerance required is only 1% or so, the user being concerned mainly that the circuit *will* oscillate. In that case, C_{X1} and C_{X2} can be selected rather freely in the range of 20 to 80 pF.

As you can see, “best” values for these components and their tolerances are strongly dependent on the application and its requirements. In any case, their suitability should be verified by environmental testing before the design is submitted to production.

MCS®-48 Oscillator

The NMOS and HMOS MCS-48 oscillator is shown in Figure 21. It differs from the 8051 in that its inverting

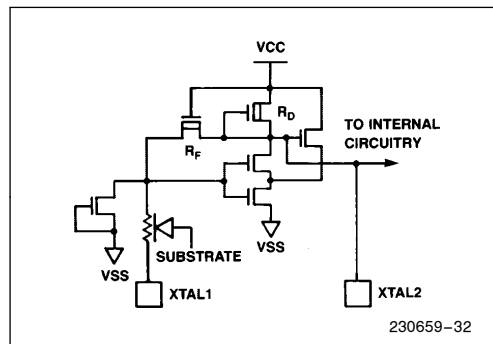

Figure 21. MCS®-48 Oscillator Amplifier

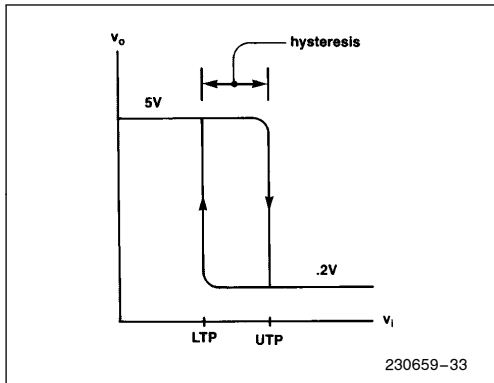

Figure 22. Schmitt Trigger Characteristic

amplifier is a Schmitt Trigger. This configuration was chosen to prevent crosstalk from the TO pin, which is adjacent to the XTAL1 pin.

All Schmitt Trigger circuits exhibit a hysteresis effect, as shown in Figure 22. The hysteresis is what makes it less sensitive to noise. The same hysteresis allows any Schmitt Trigger to be used as a relaxation oscillator. All you have to do is connect a resistor from output to input, and a capacitor from input to ground, and the circuit oscillates in a relaxation mode as follows.

If the Schmitt Trigger output is at a logic high, the capacitor commences charging through the feedback resistor. When the capacitor voltage reaches the upper trigger point (UTP), the Schmitt Trigger output switches to a logic low and the capacitor commences discharging through the same resistor. When the capacitor voltage reaches the lower trigger point (LTP), the Schmitt Trigger output switches to a logic high again, and the sequence repeats. The oscillation frequency is determined by the RC time constant and the hysteresis voltage, $UTP-LTP$.

The 8048 can oscillate in this mode. It has an internal feedback resistor. All that's needed is an external capacitor from XTAL1 to ground. In fact, if a smaller external feedback resistor is added, an 8048 system could be designed to run in this mode. *Do it at your own risk!* This mode of operation is not tested, specified, documented, or encouraged in any way by Intel for the 8048. Future steppings of the device might have a different type of inverting amplifier (one more like the 8051). The CHMOS members of the MCS-48 family do not use a Schmitt Trigger as the inverting amplifier.

Relaxation oscillations in the 8048 must be avoided, and this is the major objective in selecting the off-chip components needed to complete the oscillator circuit.

When an 8048 is powered up, if VCC has a short rise time, the relaxation mode starts first. The frequency is normally about 50 KHz. The resonator mode builds

more slowly, but it eventually takes over and dominates the operation of the circuit. This is shown in Figure 23A.

Due to processing variations, some units seem to have a harder time coming out of the relaxation mode, particularly at low temperatures. In some cases the resonator oscillations may fail entirely, and leave the device in the relaxation mode. Most units will stick in the relaxation mode at any temperature if C_{X1} is larger than about 50 pF. Therefore, C_{X1} should be chosen with some care, particularly if the system must operate at lower temperatures.

One method that has proven effective in all units to -40°C is to put 5 pF from XTAL1 to ground and 20 pF from XTAL2 to ground. Unfortunately, while this method does discourage the relaxation mode, it is not an optimal choice for the resonator mode. For one thing, it does not swamp the pin capacitance. Also, it makes for a rather high signal level at XTAL1 (8 or 9 volts peak-to-peak).

The question arises as to whether that level of signal at XTAL1 might damage the chip. Not to worry. The negative peaks are self-limiting and nondestructive. The positive peaks could conceivably damage the oxide, but in fact, NMOS chips (eg, 8048) and HMOS chips (eg, 8048H) are tested to a much higher voltage than that. The technology trend, of course, is to thinner oxides, as the devices shrink in size. For an extra margin of safety, the HMOS II chips (eg, 8048AH) have an internal diode clamp at XTAL1 to VCC.

In reality, C_{X1} doesn't have to be quite so small to avoid relaxation oscillations, if the minimum operating temperature is not -40°C . For less severe temperature requirements, values of capacitance selected in much the same way as for an 8051 can be used. The circuit should be tested, however, at the system's lowest temperature limit.

Additional security against relaxation oscillations can be obtained by putting a 1M-ohm (or larger) resistor from XTAL1 to VCC. Pulling up the XTAL1 pin this way seems to discourage relaxation oscillations as effectively as any other method (Figure 23B).

Another thing that discourages relaxation oscillations is low VCC. The resonator mode, on the other hand is much less sensitive to VCC. Thus if VCC comes up relatively slowly (several milliseconds rise time), the resonator mode is normally up and running before the relaxation mode starts (in fact, before VCC has even reached operating specs). This is shown in Figure 23C.

A secondary effect of the hysteresis is a shift in the oscillation frequency. At low frequencies, the output signal from an inverter without hysteresis leads (or lags) the input by 180 degrees. The hysteresis in a Schmitt Trigger, however, causes the output to lead the

input by less than 180 degrees (or lag by more than 180 degrees), by an amount that depends on the signal amplitude, as shown in Figure 24. At higher frequencies, there are additional phase shifts due to the various reactances in the circuit, but the phase shift due to the hysteresis is still present. Since the total phase shift in the oscillator's loop gain is necessarily 0 or 360 degrees, it is apparent that as the oscillations build up, the frequency has to change to allow the reactances to compensate for the hysteresis. In normal operation, this additional phase shift due to hysteresis does not exceed a few degrees, and the resulting frequency shift is negligible.

Kyocera, a ceramic resonator manufacturer, studied the use of some of their resonators (at 6.0 MHz, 8.0 MHz, and 11.0 MHz) with the 8049H. Their conclusion as to the value of capacitance to use at XTAL1 and XTAL2 was that 33 pF is appropriate at all three frequencies. One should probably follow the manufacturer's recommendations in this matter, since they will guarantee operation.

Whether one should accept these recommendations and guarantees without further testing is, however, another matter. Not all users have found the recommendations to be without occasional problems. If you run into diffi-

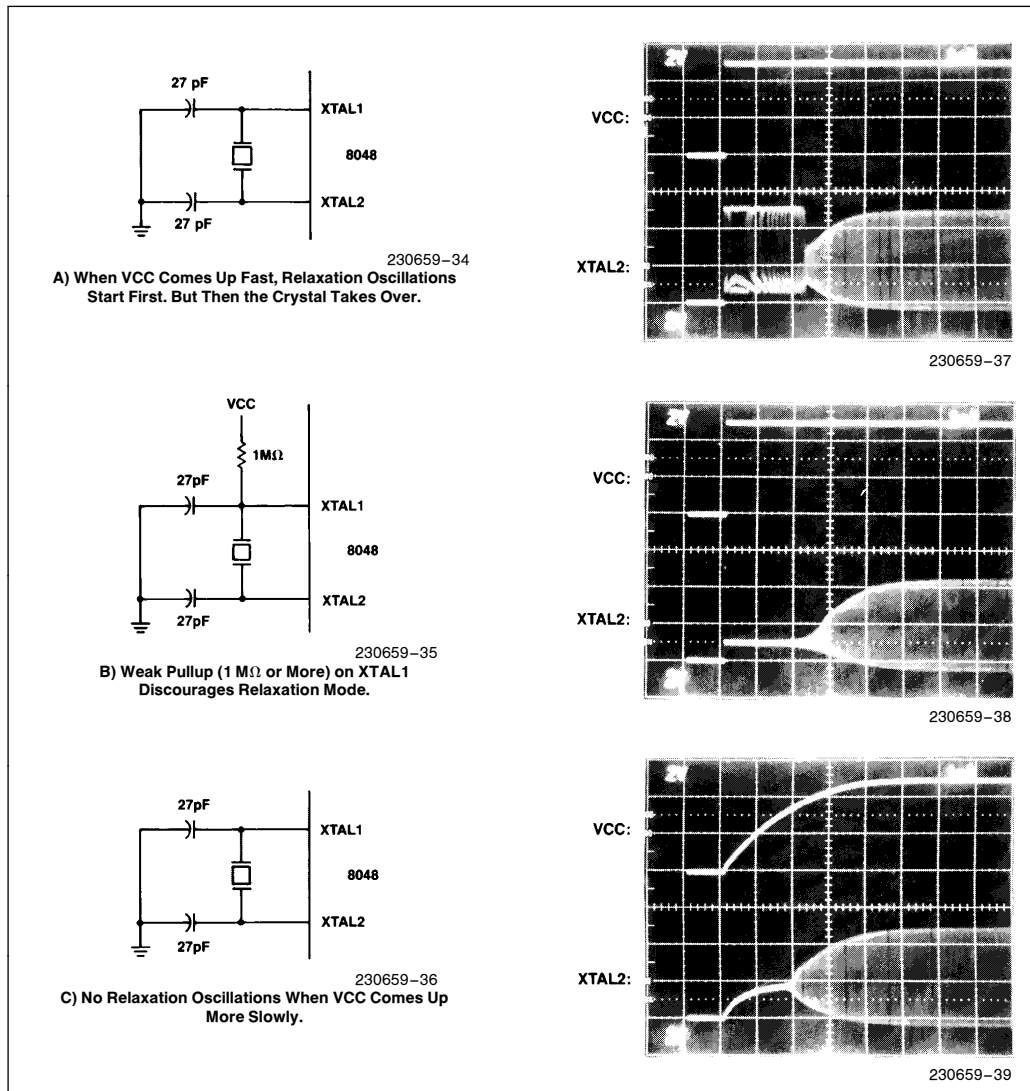

Figure 23. Relaxation Oscillations in the 8048

culties using their recommendations, both Intel and the ceramic resonator manufacturer want to know about it. It is to their interest, and ours, that such problems be resolved.

It will be helpful to build a test jig that will allow the oscillator circuit to be tested independently of the rest of the system. Both start-up and steady-state characteristics should be tested. Figure 25 shows the circuit that

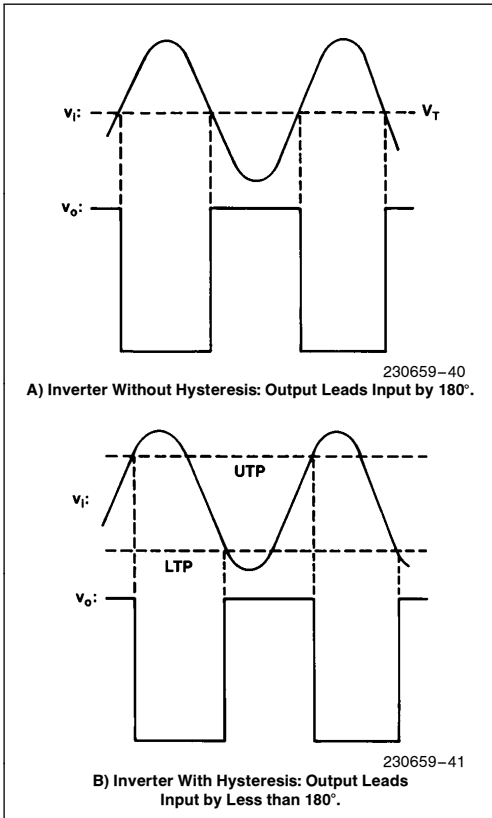

Figure 24. Amplitude—Dependent Phase Shift in Schmitt Trigger

Preproduction Tests

An oscillator design should never be considered ready for production until it has proven its ability to function acceptably well under worst-case environmental conditions and with parameters at their worst-case tolerance limits. Unexpected temperature effects in parts that may already be near their tolerance limits can prevent start-up of an oscillator that works perfectly well on the bench. For example, designers often overlook temperature effects in ceramic capacitors. (Some ceramics are down to 50% of their room-temperature values at -20°C and $+60^{\circ}\text{C}$). The problem here isn't just one of frequency stability, but also involves start-up time and steady-state amplitude. There may also be temperature effects in the resonator and amplifier.

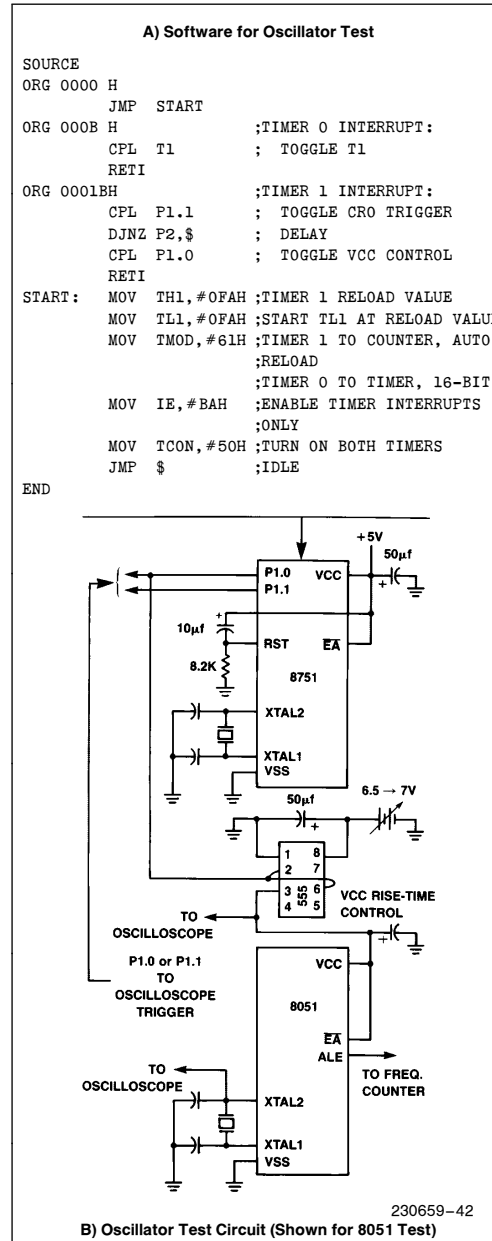

Figure 25. Oscillator Test Circuit and Software

was used to obtain the oscillator start-up photographs in this Application Note. This circuit or a modified version of it would make a convenient test vehicle. The oscillator and its relevant components can be physically separated from the control circuitry, and placed in a temperature chamber.

Start-up should be observed under a variety of conditions, including low VCC and using slow and fast VCC rise times. The oscillator should not be reluctant to start up even when VCC is below its spec value for the rest of the chip. (The rest of the chip may not function, but the oscillator should work.) It should also be verified that start-up occurs when the resonator has more than its upper tolerance limit of series resistance. (Put some resistance in series with the resonator for this test.) The bulk capacitors from XTAL1 and XTAL2 to ground should also be varied to their tolerance limits.

The same circuit, with appropriate changes in the software to lengthen the “on” time, can be used to test the steady-state characteristics of the oscillator, specifically the frequency, frequency stability, and amplitudes at XTAL1 and XTAL2.

As previously noted, the voltage swings at these pins are not critical, but they should be checked at the system’s temperature limits to ensure that they are in good health. Observing these signals necessarily changes them somewhat. Observing the signal at XTAL2 requires that the capacitor at that pin be reduced to account for the oscilloscope probe capacitance. Observing the signal at XTAL1 requires the same consideration, plus a blocking capacitor (switch the oscilloscope input to AC), so as to not disturb the DC level at that pin. Alternatively, a MOSFET buffer such as the one shown in Figure 26 can be used. It should be verified by direct measurement that the ground clip on the scope probe is ohmically connected to the scope chassis (probes are incredibly fragile in this respect), and the observations should be made with the ground clip on the VSS pin, or very close to it. If the probe shield isn’t operational and in use, the observations are worthless.

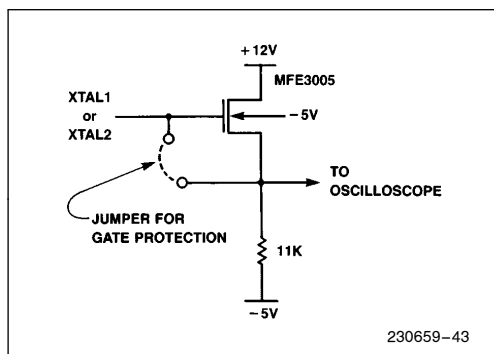

Figure 26. MOSFET Buffer for Observing Oscillator Signals

Frequency checks should be made with only the oscillator circuitry connected to XTAL1 and XTAL2. The ALE frequency can be counted, and the oscillator frequency derived from that. In systems where the frequency tolerance is only “nominal,” the frequency should still be checked to ascertain that the oscillator isn’t running in a spurious resonance or relaxation mode. Switching VCC off and on again repeatedly will help reveal a tendency to go into unwanted modes of oscillation.

The operation of the oscillator should then be verified under actual system running conditions. By this stage one will be able to have some confidence that the basic selection of components for the oscillator itself is suitable, so if the oscillator appears to malfunction in the system the fault is not in the selection of these components.

Troubleshooting Oscillator Problems

The first thing to consider in case of difficulty is that between the test jig and the actual application there may be significant differences in stray capacitances, particularly if the actual application is on a multi-layer board.

Noise glitches, that aren’t present in the test jig but are in the application board, are another possibility. Capacitive coupling between the oscillator circuitry and other signal has already been mentioned as a source of miscounts in the internal clocking circuitry. Inductive coupling is also possible, if there are strong currents nearby. These problems are a function of the PCB layout.

Surrounding the oscillator components with “quiet” traces (VCC and ground, for example) will alleviate capacitive coupling to signals that have fast transition times. To minimize inductive coupling, the PCB layout should minimize the areas of the loops formed by the oscillator components. These are the loops that should be checked:

- XTAL1 through the resonator to XTAL2;
- XTAL1 through C_{X1} to the VSS pin;
- XTAL2 through C_{X2} to the VSS pin.

It is not unusual to find that the grounded ends of C_{X1} and C_{X2} eventually connect up to the VSS pin only after looping around the farthest ends of the board. Not good.

Finally, it should not be overlooked that software problems sometimes imitate the symptoms of a slow-starting oscillator or incorrect frequency. Never underestimate the perversity of a software problem.

REFERENCES

1. Frerking, M. E., *Crystal Oscillator Design and Temperature Compensation*, Van Nostrand Reinhold, 1978.
2. Bottom, V., "The Crystal Unit as a Circuit Component," Ch. 7, *Introduction to Quartz Crystal Unit Design*, Van Nostrand Reinhold, 1982.
3. Parzen, B., *Design of Crystal and Other Harmonic Oscillators*, John Wiley & Sons, 1983.
4. Holmbeck, J. D., "Frequency Tolerance Limitations with Logic Gate Clock Oscillators, *31st Annual Frequency Control Symposium*, June, 1977.
5. Roberge, J. K., "Nonlinear Systems," Ch. 6, *Operational Amplifiers: Theory and Practice*, Wiley, 1975.
6. Eaton, S. S. *Timekeeping Advances Through COS/MOS Technology*, RCA Application Note ICAN-6086.
7. Eaton, S. S., *Micropower Crystal-Controlled Oscillator Design Using RCA COS/MOS Inverters*, RCA Application Note ICAN-6539.
8. Fisher, J. B., *Crystal Specifications for the Intel 8031/8051/8751 Microcontrollers*, Standard Crystal Corp. Design Data Note #2F.
9. Murata Mfg. Co., Ltd., *Ceramic Resonator "Ceralock" Application Manual*.
10. Kyoto Ceramic Co., Ltd., *Adaptability Test Between Intel 8049H and Kyocera Ceramic Resonators*.
11. Kyoto Ceramic Co., Ltd., *Technical Data on Ceramic Resonator Model KBR-6.0M, KBR-8.0M, KBR-11.0M Application for 8051 (Intel)*.
12. NTK Technical Ceramic Division, NGK Spark Plug Co., Ltd., *NTKK Ceramic Resonator Manual*.

APPENDIX A QUARTZ AND CERAMIC RESONATOR FORMULAS

Based on the equivalent circuit of the crystal, the impedance of the crystal is

$$Z_{\text{XTAL}} = \frac{(R_1 + j\omega L_1 + 1/j\omega C_1)(1/j\omega C_0)}{R_1 + j\omega L_1 + 1/j\omega C_1 + 1/j\omega C_0}$$

After some algebraic manipulation, this calculation can be written in the form

$$Z_{\text{XTAL}} = \frac{1}{j\omega(C_1 + C_0)} \cdot \frac{1 - \omega^2 L_1 C_1 + j\omega R_1 C_1}{1 - \omega^2 L_1 C_T + j\omega R_1 C_T}$$

where C_T is the capacitance of C_1 in series with C_0 :

$$C_T = \frac{C_1 C_0}{C_1 + C_0}$$

The impedance of the crystal in parallel with an external load capacitance C_L is the same expression, but with $C_0 + C_L$ substituted for C_0 :

$$Z_{\text{XTAL}} \parallel C_L = \frac{1}{j\omega(C_1 + C_0 + C_L)} \cdot \frac{1 - \omega^2 L_1 C_1 + j\omega R_1 C_1}{1 - \omega^2 L_1 C'_T + j\omega R_1 C'_T}$$

where C'_T is the capacitance of C_1 in series with $(C_0 + C_L)$:

$$C'_T = \frac{C_1(C_0 + C_L)}{C_1 + C_0 + C_L}$$

The impedance of the crystal in series with the load capacitance is

$$\begin{aligned} Z_{\text{XTAL}} + C_L &= Z_{\text{XTAL}} + \frac{1}{j\omega C_L} \\ &= \frac{C_L + C_1 + C_0}{j\omega C_L(C_1 + C_0)} \cdot \frac{1 - \omega^2 L_1 C'_T + j\omega R_1 C'_T}{1 - \omega^2 L_1 C_T + j\omega R_1 C_T} \end{aligned}$$

where C_T and C'_T are as defined above.

The phase angles of these impedances are readily obtained from the impedance expressions themselves:

$$\begin{aligned} \theta_{\text{XTAL}} &= \arctan \frac{\omega R_1 C_1}{1 - \omega^2 L_1 C_1} \\ &\quad - \arctan \frac{\omega R_1 C_T}{1 - \omega^2 L_1 C_T} - \frac{\pi}{2} \end{aligned}$$

$$\begin{aligned} \theta_{\text{XTAL}} \parallel C_L &= \arctan \frac{\omega R_1 C_1}{1 - \omega^2 L_1 C_1} \\ &\quad - \arctan \frac{\omega R_1 C'_T}{1 - \omega^2 L_1 C'_T} - \frac{\pi}{2} \end{aligned}$$

$$\begin{aligned} \theta_{\text{XTAL}} + C_L &= \arctan \frac{\omega R_1 C'_T}{1 - \omega^2 L_1 C'_T} \\ &\quad - \arctan \frac{\omega R_1 C_T}{1 - \omega^2 L_1 C_T} - \frac{\pi}{2} \end{aligned}$$

The resonant (“series resonant”) frequency is the frequency at which the phase angle is zero and the impedance is low. The antiresonant (“parallel resonant”) frequency is the frequency at which the phase angle is zero and the impedance is high.

Each of the above θ -expressions contains two arctan functions. Setting the denominator of the argument of the first arctan function to zero gives (approximately) the “series resonant” frequency for that configuration. Setting the denominator of the argument of the second arctan function to zero gives (approximately) the “parallel resonant” frequency for that configuration.

For example, the resonant frequency of the crystal is the frequency at which

$$1 - \omega^2 L_1 C_1 = 0$$

Thus
$$\omega_s = \frac{1}{\sqrt{L_1 C_1}}$$

or
$$f_s = \frac{1}{2\pi \sqrt{L_1 C_1}}$$

It will be noted that the series resonant frequency of the “XTAL + CL” configuration (crystal in series with CL) is the same as the parallel resonant frequency of the “XTAL || CL” configuration (crystal in parallel with C_L). This is the frequency at which

$$1 - \omega^2 L_1 C'_T = 0$$

Thus

$$\omega_a = \frac{1}{\sqrt{L_1 C'_T}}$$

or

$$f_a = \frac{1}{2\pi\sqrt{L_1 C'_T}}$$

This fact is used by crystal manufacturers in the process of calibrating a crystal to a specified load capacitance.

By subtracting the resonant frequency of the crystal from its antiresonant frequency, one can calculate the range of frequencies over which the crystal reactance is positive:

$$f_a - f_s = f_s \left(\sqrt{1 + C_1/C_0} - 1 \right)$$

$$f_s \left(\frac{C_1}{2C_0} \right)$$

Given typical values for C_1 and C_0 , this range can hardly exceed 0.5% of f_s . Unless the inverting amplifier in the positive reactance oscillator is doing something very strange indeed, the oscillation frequency is bound to be accurate to that percentage whether the crystal was calibrated for series operation or to any unspecified load capacitance.

Equivalent Series Resistance

ESR is the real part of Z_{XTAL} at the oscillation frequency. The oscillation frequency is the parallel resonant frequency of the “XTAL || CL” configuration (which is the same as the series resonant frequency of the “XTAL + CL” configuration). Substituting this frequency into the Z_{XTAL} expression yields, after some algebraic manipulation,

$$ESR = \frac{R_1 \left(\frac{C_0 + C_L}{C_L} \right)^2}{1 + \omega^2 C_1^2 \left(\frac{C_0 + C_L}{C_L} \right)^2}$$

$$\cong R_1 \left(1 + \frac{C_0}{C_L} \right)^2$$

Drive Level

The power dissipated by the crystal is $I_1^2 R_1$, where I_1 is the RMS current in the motional arm of the crystal. This current is given by $V_x/|Z_1|$, where V_x is the RMS voltage across the crystal, and $|Z_1|$ is the magnitude of the impedance of the motional arm. At the oscillation frequency, the motional arm is a positive (inductive) reactance in parallel resonance with $(C_0 + C_L)$. Therefore $|Z_1|$ is approximately equal to the magnitude of the reactance of $(C_0 + C_L)$:

$$|Z_1| = \frac{1}{2\pi f(C_0 + C_L)}$$

where f is the oscillation frequency. Then,

$$P = I_1^2 R_1 = \left(\frac{V_x}{|Z_1|} \right)^2 R_1$$

$$= [2\pi f (C_0 + C_L) V_x]^2 R_1$$

The waveform of the voltage across the crystal (XTAL1 to XTAL2) is approximately sinusoidal. If its peak value is V_{CC} , then V_x is $V_{CC}/\sqrt{2}$. Therefore,

$$P = 2R_1 [\pi f (C_0 + C_L) V_{CC}]^2$$



APPENDIX B OSCILLATOR ANALYSIS PROGRAM

The program is written in BASIC. BASIC is excruciatingly slow, but it has some advantages. For one thing, more people know BASIC than FORTRAN. In addition, a BASIC program is easy to develop, modify, and “fiddle around” with. Another important advantage is that a BASIC program can run on practically any small computer system.

Its slowness is a problem, however. For example, the routine which calculates the “start-up time constant” discussed in the text may take several hours to complete. A person who finds this program useful may prefer to convert it to FORTAN, if the facilities are available.

Limitations of the Program

The program was developed with specific reference to 8051-type oscillator circuitry. That means the on-chip amplifier is a simple inverter, and not a Schmitt Trigger. The 8096, the 80C51, the 80C48 and 80C49 all have simple inverters. The 8096 oscillator is almost identical to the 8051, differing mainly in the input protection circuitry. The CHMOS amplifiers have somewhat different parameters (higher gain, for example), and different transition levels than the 8051.

The MCS-48 family is specifically included in the program only to the extent that the input-output curve used in the steady-state analysis is that of a Schmitt Trigger, if the user identifies the device under analysis as an MCS-48 device. The analysis does not include the voltage dependent phase shift of the Schmitt Trigger.

The clamping action of the input protection circuitry is important in determining the steady-state amplitudes. The steady-state routine accounts for it by setting the negative peak of the XTAL1 signal at a level which depends on the amplitude of the XTAL1 signal in accordance with experimental observations. It's an exercise in curve-fitting. A user may find a different type of curve works better. Later steppings of the chips may behave differently in this respect, having somewhat different types of input protection circuitry.

It should be noted that the analysis ignores a number of important items, such as high-frequency effects in the on-chip circuitry. These effects are difficult to predict, and are no doubt dependent on temperature, frequency, and device sample. However, they can be simulated to a reasonable degree by adding an “output capacitance” of about 20 pF to the circuit model (i.e., in parallel with CX2) as described below.

Notes on Using the Program

The program asks the user to input values for various circuit parameters. First the crystal (or ceramic resonator) parameters are asked for. These are R1, L1, C1, and C0. The manufacturer can supply these values for selected samples. To obtain any kind of correlation between calculation and experiment, the values of these parameters must be known for the specific sample in the test circuit. The value that should be entered for C0 is the C0 of the crystal itself plus an estimated 7 pF to account for the XTAL1-to-XTAL2 pin capacitance, plus any other stray capacitance paralleling the crystal that the user may feel is significant enough to be included.

Then the program asks for the values of the XTAL1-to-ground and XTAL2-to-ground capacitances. For CXTAL1, enter the value of the externally connected bulk capacitor plus an estimated 7 pF for pin capacitance. For CXTAL2, enter the value of the externally connected bulk capacitor plus an estimated 7 pF for pin capacitance plus about 20 pF to simulate high-frequency roll-off and phase shifts in the on-chip circuitry.

Next the program asks for values for the small-signal parameters of the on-chip amplifier. Typically, for the 8051/8751,

Amplifier Gain Magnitude = 15
Feedback Resistance = 2300 K Ω
Output Resistance = 2 K Ω

The same values can be used for MCS-48 (NMOS and HMOS) devices, but they are difficult to verify, because the Schmitt Trigger does not lend itself to small-signal measurements.

```

100 DEFDBL C,D,F,G,L,P,R,S,X
200 REM
300 REM *****
400 REM
500 REM
600 REM
700 REM
800 REM FNZM(R,X) = MAGNITUDE OF A COMPLEX NUMBER, (R+JX)
900 DEF FNZM(R,X) = SQR(R^2+X^2)
1000 REM
1100 REM FNZP(R,X) = ANGLE OF A COMPLEX NUMBER
1200 REM = 180/PI*ARCTAN(X/R) IF R>0
1300 REM = 180/PI*ARCTAN(X/R) + 180 IF R<0 AND X>0
1400 REM = 180/PI*ARCTAN(X/R) - 180 IF R<0 AND X<0
1500 DEF FNZP(R,X) = 180/PI*ATN(X/R) - (SGN(R)-1)*SGN(X)*90
1600 REM
1700 REM INDUCTIVE IMPEDANCE AT COMPLEX FREQUENCY S+JF (HZ)
1800 REM Z = 2*PI*S*L + J2*PI*F*L
1900 REM = FNRL(S,L) + JFNXL(F,L)
2000 DEF FNRL(SL,LL) = 2**PI*SL*LL
2100 DEF FNXL(FL,LL) = 2**PI*FL*LL
2200 REM
2300 REM CAPACITIVE IMPEDANCE AT COMPLEX FREQUENCY S+JF (HZ)
2400 REM Z = 1/[2*PI*(S+JF)*C]
2500 REM = S/[2*PI*(S^2+F^2)*C] + J(-F)/[2*PI*(S^2+F^2)C]
2600 REM = FNRC(S,F,C) + JFNXC(S,F,C)
2700 DEF FNRC(SC,FC,CC) = SC/(2**PI*(SC^2+FC^2)*CC)
2800 DEF FNXC(SC,FC,CC) = -FC/(2**PI*(SC^2+FC^2)*CC)
2900 REM
3000 REM RATIO OF TWO COMPLEX NUMBERS
3100 REM RA+JXA RA*RB+XA*XB XA*RB-RA*XB
3200 REM ----- = ----- + J -----
3300 REM RB+JXB RB^2+XB^2 RB^2+XB^2
3400 REM = FNRR(RA, XA, RB, XB) + JFNXR(RA, XA, RB, XB)
3500 DEF FNRR(RA, XA, RB, XB) = (RA*RB+XA*XB)/(RB^2+XB^2)
3600 DEF FNXR(RA, XA, RB, XB) = (XA*RB-RA*XB)/(RB^2+XB^2)
3700 REM
3800 REM PRODUCT OF TWO COMPLEX NUMBERS
3900 REM (RA+JXA)*(RB+JXB) = RA*RB-XA*XB + J(XA*RB+RA*XB)
4000 REM = FNRM(RA, XA, RB, XB) + JFNXM(RA, XA, RB, XB)
4100 DEF FNRM(RA, XA, RB, XB) = RA*RB - XA*XB
4200 DEF FNXM(RA, XA, RB, XB) = XA*XB + RB*XA
4300 REM
4400 REM
4500 REM PARALLEL IMPEDANCES
4600 REM (RA+JXA):(RB+JXB) = (RA+JXA)*(RB+JXB)
4700 REM -----
4800 REM RA+RB + J(XA+XB)
4900 REM
5000 REM RA*(RB^2+XB^2)+RB*(RA^2+XA^2) XA*(RB^2+XB^2)+XB*(RA^2+XA^2)
5100 REM = ----- + J -----
5200 REM (RA+RB)^2 + (XA+XB)^2 (RA+RB)^2 + (XA+XB)^2
5300 REM
5400 REM = FNRP(RA, XA, RB, XB) + JFNXP(RA, XA, RB, XB)
5500 DEF FNRP(RA, XA, RB, XB) = (RA*(RB^2+XB^2) + RB*(RA^2+XA^2))/((RA+RB)^2 + (XA+XB)^2)
5600 DEF FNXP(RA, XA, RB, XB) = (XA*(RB^2+XB^2) + XB*(RA^2+XA^2))/((RA+RB)^2 + (XA+XB)^2)
5700 REM
5800 REM *****
5900 REM
6000 REM BEGIN COMPUTATIONS
6100 REM
6200 LET PI = 3.141592654#
6300 REM
6400 REM DEFINE CIRCUIT PARAMETERS
6500 GOSUB 14500
6600 REM
6700 REM ESTABLISH NOMINAL RESONANT AND ANTIRESONANT CRYSTAL FREQUENCIES
6800 FS = FIX(1/(2*PI*SQR(L1*C1)))
6900 FA = FIX(1/(2*PI*SQR(L1*C1*CO/(C1+CO))))
7000 PRINT
7100 PRINT "XTAL IS SERIES RESONANT AT ",FS," HZ"
7200 PRINT " PARALLEL RESONANT AT ",FA," HZ"
7300 PRINT
7400 PRINT "SELECT 1 LIST PARAMETERS"
7500 PRINT " 2 CIRCUIT ANALYSIS"
7600 PRINT " 3 OSCILLATION FREQUENCY"
7700 PRINT " 4 START-UP TIME CONSTANT"
7800 PRINT " 5 STEADY-STATE ANALYSIS"

```

```

7900 PRINT
8000 INPUT N
8100 IF N=1 THEN PRINT ELSE 8600
8200 REM
8300 REM ----- LIST PARAMETERS -----
8400 GOSUB 17100
8500 GOTO 6800
8600 IF N=2 THEN PRINT ELSE 9400
8700 REM
8800 REM ----- CIRCUIT ANALYSIS -----
8900 PRINT " FREQUENCY S+JF TYPE (S), (F) "
9000 INPUT SQ,FG
9100 GOSUB 20200
9200 GOSUB 26600
9300 GOTO 6800
9400 IF N=3 THEN 10300 ELSE 11000
9500 REM
9600 REM ----- OSCILLATION FREQUENCY -----
9700 CL = CX*CY/(CX+CY) + CO
9800 FG = FIX(1/(2*PI*SQR(L1*C1*CL/(C1+CL))))
9900 SQ = 0
10000 DF = FIX(10^INT(LOG(FA-FS)/LOG(10)-2)+.5)
10100 DS = 0
10200 RETURN
10300 GOSUB 9700
10400 GOSUB 30300
10500 PRINT
10600 PRINT
10700 PRINT "FREQUENCY AT WHICH LOOP GAIN HAS ZERO PHASE ANGLE."
10800 GOSUB 26600
10900 GOTO 6800
11000 IF N=4 THEN PRINT ELSE 12200
11100 REM
11200 REM ----- START-UP TIME CONSTANT -----
11300 PRINT "THIS WILL TAKE SOME TIME ....."
11400 GOSUB 9700
11500 GOSUB 37700
11600 PRINT
11700 PRINT
11800 PRINT "FREQUENCY AT WHICH LOOP GAIN = 1 AT 0 DEGREES:"
11900 GOSUB 26600
12000 PRINT : PRINT "THIS YIELDS A START-UP TIME CONSTANT OF ";CSNG(1000000/(2*PI*SQ));" MICROSECS"
12100 GOTO 6800
12200 IF N=5 THEN PRINT ELSE 7300
12300 REM
12400 REM ----- STEADY-STATE ANALYSIS -----
12500 PRINT "STEADY-STATE ANALYSIS"
12600 PRINT
12700 PRINT "SELECT:  1  8031/8051"
12800 PRINT "          2  8751"
12900 PRINT "          3  8035/8039/8040/8048/8049"
13000 PRINT "          4  8748/8749"
13100 INPUT IC%
13200 IF IC%<1 OR IC%>4 THEN 12600
13300 GOSUB 46900
13400 GOTO 7300
13500 REM  SUBROUTINE BELOW DEFINES INPUT-OUTPUT CURVE OF OSCILLATOR CKT
13600 IF IC%>2 AND VO=5 AND VI<2 THEN RETURN
13700 VO = -10*VI + 15
13800 IF VO>5 THEN VO = 5
13900 IF VO<2 THEN VO = .2
14000 IF IC%>2 AND VO>2 THEN VO = 5
14100 RETURN
14200 REM
14300 REM *****
14400 REM
14500 REM          DEFINE CIRCUIT PARAMETERS
14600 REM
14700 INPUT " R1 (OHMS)";R1
14800 INPUT " L1 (HENRY)";L1
14900 INPUT " C1 (PF)";X
15000 C1 = X*1E-12
15100 INPUT " CO (PF)";X
15200 CO = X*1E-12
15300 INPUT " CXTAL1 (PF)";X
15400 CX = X*1E-12
15500 INPUT " CXTAL2 (PF)";X
15600 CY = X*1E-12
    
```

```

15700 INPUT " GAIN FACTOR MAGNITUDE";AV#
15800 INPUT " AMP FEEDBACK RESISTANCE (K-OHMS)"; X
15900 RX = X*1000#
16000 INPUT " AMP OUTPUT RESISTANCE (K-OHMS)"; X
16100 RO = X*1000#
16200 REM
16300 REM
16400 REM          LIST CURRENT PARAMETER VALUES
16500 GOSUB 17100
16600 RETURN
16700 REM
16800 REM
16900 REM *****
17000 REM
17100 REM          LIST CURRENT PARAMETER VALUES
17200 REM
17300 PRINT
17400 PRINT "CURRENT PARAMETER VALUES:  1. R1 = ";R1;" OHMS"
17500 PRINT "                               2. L1 = ";CSNG(L1);" HENRY"
17600 PRINT "                               3. C1 = ";CSNG(C1*1E+12);" PF"
17700 PRINT "                               4. C0 = ";CSNG(C0*1E+12);" PF"
17800 PRINT "                               5. CXTAL1 = ";CSNG(CX*1E+12);" PF"
17900 PRINT "                               6. CXTAL2 = ";CSNG(CY*1E+12);" PF"
18000 PRINT "       7. AMPLIFIER GAIN MAGNITUDE = ";AV#
18100 PRINT "       8. FEEDBACK RESISTANCE = ";CSNG(RX* 001);" K-OHMS"
18200 PRINT "       9. OUTPUT RESISTANCE = ";CSNG(RO* 001);" K-OHMS"
18300 PRINT
18400 PRINT "TO CHANGE A PARAMETER VALUE, TYPE (PARAM NO.),(NEW VALUE). "
18500 PRINT "OTHERWISE, TYPE 0,0 "
18600 INPUT N%,X
18700 IF N%=0 THEN RETURN
18800 IF N%=1 THEN R1 = X
18900 IF N%=2 THEN L1 = X
19000 IF N%=3 THEN C1 = X*1E-12
19100 IF N%=4 THEN C0 = X*1E-12
19200 IF N%=5 THEN CX = X*1E-12
19300 IF N%=6 THEN CY = X*1E-12
19400 IF N%=7 THEN AV# = X
19500 IF N%=8 THEN RX = X*1000#
19600 IF N%=9 THEN RO = X*1000#
19700 GOTO 17400
19800 REM
19900 REM
20000 REM *****
20100 REM
20200 REM          CIRCUIT ANALYSIS
20300 REM
20400 REM This routine calculates the loop gain at complex frequency SQ+jFG.
20500 REM
20600 REM 1. Crystal impedance: RE + jXE
20700 REM
20800 X1 = FNXL(FG,L1) + FNXC(SG,FG,C1)
20900 RE = FNRP((R1+FNRL(SG,L1)+FNRC(SG,FG,C1)),X1,FNRC(SG,FG,C0),FNXC(SG,FG,C0))
21000 XE = FNXP((R1+FNRL(SG,L1)+FNRC(SG,FG,C1)),X1,FNRC(SG,FG,C0),FNXC(SG,FG,C0))
21100 REM
21200 REM 2. RF + jXF = (RE+jXE):(amplifier feedback resistance)
21300 REM
21400 RF = FNRP(RX,0,RE,XE)
21500 XF = FNXP(RX,0,RE,XE)
21600 REM
21700 REM 3. Input impedance: Zi = RI + jXI = impedance of CXTAL1
21800 REM
21900 RI = FNRC(SG,FG,CX)
22000 XI = FNXC(SG,FG,CX)
22100 REM
22200 REM 4. Load impedance: ZL = (impedance of CXTAL2):(RF+RI)+j(XF+XI)
22300 REM
22400 RL = FNRP((RF+RI),(XF+XI),FNRC(SG,FG,CY),FNXC(SG,FG,CY))
22500 XL = FNXP((RF+RI),(XF+XI),FNRC(SG,FG,CY),FNXC(SG,FG,CY))
22600 REM
22700 REM 5. Amplifier gain A = -AV*ZL/(ZL+RO)
22800 REM          = A(real) + jA(imaginary)
22900 REM
23000 AR# = -AV#*FNRP(RL,XL,(RO+RL),XL)
23100 AI# = -AV#*FNXP(RL,XL,(RO+RL),XL)
23200 REM
23300 REM 6. Feedback ratio (beta) = (RI+jXI)/[(RF+RI)+j(XF+XI)]
23400 REM          = B(real) + jB(imaginary)

```

230659-46

```

23500 REM
23600 BR# = FNRR(RI, XI, (RI+RF), (XI+XF))
23700 BI# = FNXR(RI, XI, (RI+RF), (XI+XF))
23800 REM
23900 REM 7. Amplifier gain in magnitude/phase form AR+jAI = A at AP degrees
24000 REM
24100 A = FNZM(AR#, AI#)
24200 AP = FNZP(AR#, AI#)
24300 REM
24400 REM 8 (beta) in magnitude/phase form: BR+jBI = B at BP degrees
24500 REM
24600 B = FNZM(BR#, BI#)
24700 BP = FNZP(BR#, BI#)
24800 REM
24900 REM 9. Loop gain. G = (BR+jBI)*(AR+jAI)
25000 REM = G(real) + jG(imaginary)
25100 REM
25200 GR = FNRM(AR#, AI#, BR#, BI#)
25300 GI = FNXM(AR#, AI#, BR#, BI#)
25400 REM
25500 REM 10. Loop gain in magnitude/phase form: GR+jGI = AL at AQ degrees
25600 REM
25700 AL = FNZM(GR, GI)
25800 AQ = FNZP(GR, GI)
25900 RETURN
26000 REM
26100 REM
26200 REM *****
26300 REM
26400 REM PRINT CIRCUIT ANALYSIS RESULTS
26500 REM
26600 PRINT
26700 PRINT " FREQUENCY = ", SQ, " + J", FG, " HZ"
26800 PRINT " XTAL IMPEDANCE = ", FNZM(RE, XE), " OHMS AT ", FNZP(RE, XE), " DEGREES"
26900 PRINT " (RE = ", CSNG(RE), " OHMS)"
27000 PRINT " (XE = ", CSNG(XE), " OHMS)"
27100 PRINT " LOAD IMPEDANCE = ", FNZM(RL, XL), " OHMS AT ", FNZP(RL, XL), " DEGREES"
27200 PRINT " AMPLIFIER GAIN = ", A, " AT ", AP, " DEGREES"
27300 PRINT " FEEDBACK RATIO = ", B, " AT ", BP, " DEGREES"
27400 PRINT " LOOP GAIN = ", AL, " AT ", AQ, " DEGREES"
27500 RETURN
27600 REM
27700 REM
27800 REM *****
27900 REM
28000 REM SEARCH FOR FREQUENCY (S+jF)
28100 REM AT WHICH LOOP GAIN HAS ZERO PHASE ANGLE
28200 REM
28300 REM This routine searches for the frequency at which the imaginary part
28400 REM of the loop gain is zero. The algorithm is as follows:
28500 REM 1. Calculate the sign of the imaginary part of the loop gain (GI).
28600 REM 2. Increment the frequency.
28700 REM 3. Calculate the sign of GI at the incremented frequency.
28800 REM 4. If the sign of GI has not changed, go back to 2.
28900 REM 5. If the sign of GI has changed, and this frequency is within
29000 REM 1Hz of the previous sign-change, exit the routine.
29100 REM 6. Otherwise, divide the frequency increment by -10.
29200 REM 7. Go back to 2.
29300 REM The routine is entered with the starting frequency SQ+jFG and
29400 REM starting increment DS+jDF already defined by the calling program.
29500 REM In actual use either DS or DF is zero, so the routine searches for
29600 REM a GI=0 point by incrementing either SQ or FG while holding the other
29700 REM constant. It returns control to the calling program with the
29800 REM incremented part of the frequency being within 1Hz of the actual
29900 REM GI=0 point
30000 REM
30100 REM 1. CALCULATE THE SIGN OF THE IMAGINARY PART OF THE LOOP GAIN (GI).
30200 REM
30300 GOSUB 20200
30400 GOSUB 26600
30500 IF GI=0 THEN RETURN
30600 SX% = INT(SGN(GI))
30700 IF SX%=-1 THEN DS = -DS
30800 REM (REVERSAL OF DS FOR GI=0 IS FOR THE POLE-SEARCH ROUTINE.)
30900 REM
31000 REM 2 INCREMENT THE FREQUENCY.
31100 REM
31200 SP = SQ

```

230659-47

```

31300 FP = FQ
31400 SQ = SQ + DS
31500 FQ = FQ + DF
31600 REM
31700 REM 3 CALCULATE THE SIGN OF GI AT THE INCREMENTED FREQUENCY.
31800 REM
31900 GOSUB 20200
32000 GOSUB 26600
32100 IF INT(SGN(GI))=0 THEN RETURN
32200 REM
32300 REM 4. IF THE SIGN OF GI HAS NOT CHANGED, GO BACK TO 2.
32400 REM
32500 IF SX%+INT(SGN(GI))=0 THEN PRINT ELSE 31400
32600 SX% = -SX%
32700 REM
32800 REM 5 IF THE SIGN OF GI HAS CHANGED, AND IF THIS FREQUENCY IS WITHIN
32900 REM 1HZ OF THE PREVIOUS SIGN-CHANGE, AND IF GI IS NEGATIVE, THEN
33000 REM EXIT THE ROUTINE (THE ADDITIONAL REQUIREMENT FOR NEGATIVE GI
33100 REM IS FOR THE POLE-SEARCH ROUTINE )
33200 REM
33300 IF ABS(SP-SQ)<1 AND ABS(FP-FQ)<1 AND SX%=-1 THEN RETURN
33400 REM
33500 REM 6. DIVIDE THE FREQUENCY INCREMENT BY -10
33600 REM
33700 DS = -DS/10#
33800 DF = -DF/10#
33900 REM
34000 REM 7. GO BACK TO 2.
34100 REM
34200 GOTO 31200
34300 REM
34400 REM
34500 REM *****
34600 REM
34700 REM SEARCH FOR POLE FREQUENCY
34800 REM
34900 REM This routine searches for the frequency at which the loop gain = 1
35000 REM at 0 degrees. That frequency is the pole frequency of the closed-
35100 REM loop gain function. The pole frequency is a complex number, SQ+jFQ
35200 REM (Hz). Oscillator start-up ensues if SQ=0. The algorithm is based on
35300 REM the calculated behavior of the phase angle of the loop gain in the
35400 REM region of interest on the complex plane. The locus of points of zero
35500 REM phase angle crosses the j-axis at the oscillation frequency and at
35600 REM some higher frequency. In between these two crossings of the j-axis,
35700 REM the locus lies in Quadrant I of the complex plane, forming an
35800 REM approximate parabola which opens to the left. The basic plan is to
35900 REM follow the locus from where it crosses the j-axis at the oscillation
36000 REM frequency, into Quadrant I, and find the point on that locus where
36100 REM the loop gain has a magnitude of 1. The algorithm is as follows:
36200 REM 1. Find the oscillation frequency, 0+jFQ
36300 REM 2. At this frequency calculate the sign of (AL-1). (AL = magnitude
36400 REM of loop gain.)
36500 REM 3. Increment FQ.
36600 REM 4. For this value of FQ, find the value of SQ for which the loop
36700 REM gain has zero phase
36800 REM 5. For this value of SQ+jFQ, calculate the sign of (AL-1).
36900 REM 6. If the sign of (AL-1) has not changed, go back to 3
37000 REM 7. If the sign of (AL-1) has changed, and this value of FQ is
37100 REM within 1Hz of the previous sign-change, exit the routine.
37200 REM 8. Otherwise, divide the FQ-increment by -10.
37300 REM 9. Go back to 3
37400 REM
37500 REM 1. FIND THE OSCILLATION FREQUENCY, 0+jFQ
37600 REM
37700 GOSUB 9700
37800 GOSUB 30300
37900 REM
38000 REM 2. AT THIS FREQUENCY, CALCULATE THE SIGN OF (AL-1).
38100 REM
38200 SY% = INT(SGN(AL-1))
38300 IF SY%=-1 THEN STOP
38400 REM ESTABLISH INITIAL INCREMENTATION VALUE FOR FQ
38500 F1 = FQ
38600 DF = (FA-F1)/10#
38700 GOSUB 30300
38800 DE = (FQ-F1)/10#
38900 DF = 0
39000 FQ = F1

```

230659-48

```

39100 REM
39200 REM 3. INCREMENT FQ
39300 REM
39400 FQ = FQ + DE
39500 REM
39600 REM 4. FOR THIS VALUE OF FQ, FIND THE VALUE OF SQ FOR WHICH THE LOOP
39700 REM GAIN HAS ZERO PHASE (THE ROUTINE WHICH DOES THAT NEEDS DF = 0,
39800 REM SO THAT IT CAN HOLD FQ CONSTANT, AND NEEDS AN INITIAL VALUE FOR
39900 REM DS, WHICH IS ARBITRARILY SET TO DS = 1000.)
40000 REM
40100 DS = 1000#
40200 SQ = 0
40300 GOSUB 30300
40400 IF AL=1! THEN RETURN
40500 REM
40600 REM 5. FOR THIS VALUE OF SQ+JFQ, CALCULATE THE SIGN OF (AL-1).
40700 REM 6. IF THE SIGN OF (AL-1) HAS NOT CHANGED, GO BACK TO 3.
40800 REM
40900 IF SYX+INT(SGN(AL-1!))=0 THEN PRINT ELSE 39400
41000 REM
41100 REM 7. IF THE SIGN OF (AL-1) HAS CHANGED, AND THIS VALUE OF FQ IS WITHIN
41200 REM 1HZ OF THE PREVIOUS SIGN-CHANGE, EXIT THE ROUTINE.
41300 REM
41400 IF ABS(F1-FQ)<1 THEN RETURN
41500 REM
41600 REM 8. DIVIDE THE FQ-INCREMENT BY -10.
41700 REM
41800 DE = -DE/10#
41900 F1 = FQ
42000 SYX = -SYX
42100 REM
42200 REM 9. GO BACK TO 3.
42300 REM
42400 GOTO 39400
42500 REM
42600 REM
42700 REM *****
42800 REM
42900 REM STEADY-STATE ANALYSIS
43000 REM
43100 REM The circuit model used in this analysis is similar to the one used
43200 REM in the small-signal analysis, but differs from it in two respects.
43300 REM First, it includes clamping and clipping effects described in the
43400 REM text. Second, the voltage source in the Thevenin equivalent of the
43500 REM amplifier is controlled by the input voltage in accordance with an
43600 REM input-output curve defined elsewhere in the program.
43700 REM The analysis applies a sinusoidal input signal of arbitrary
43800 REM amplitude, at the oscillation frequency, to the XTAL1 pin, then
43900 REM calculates the resulting waveform from the voltage source. Using
44000 REM standard Fourier techniques, the fundamental frequency component of
44100 REM this waveform is extracted. This frequency component is then
44200 REM multiplied by the factor  $|Z_L/(Z_L+R_D)|$ , and the result is taken to be
44300 REM the signal appearing at the XTAL2 pin. This signal is then
44400 REM multiplied by the feedback ratio (beta), and the result is taken to
44500 REM be the signal appearing at the XTAL1 pin. The algorithm is now
44600 REM repeated using this computed XTAL1 signal as the assumed input
44700 REM sinusoid. Every time the algorithm is repeated, new values appear at
44800 REM XTAL1 and XTAL2, but the values change less and less with each
44900 REM repetition. Eventually they stop changing. This is the steady-state.
45000 REM The algorithm is as follows.
45100 REM 1. Compute approximate oscillation frequency.
45200 REM 2. Call a circuit analysis at this frequency.
45300 REM 3. Find the quiescent levels at XTAL1 and XTAL2 (to establish the
45400 REM beginning DC level at XTAL1).
45500 REM 4. Assume an initial amplitude for the XTAL1 signal.
45600 REM 5. Correct the DC level at XTAL1 for clamping effects, if necessary.
45700 REM 6. Using the appropriate input-output curve, extract a DC level and
45800 REM the fundamental frequency component (multiplying the latter by
45900 REM  $|Z_L/(Z_L+R_D)|$ ).
46000 REM 7. Clip off the negative portion of this output signal, if the
46100 REM negative peak falls below zero.
46200 REM 8. If this signal, multiplied by (beta), differs from the input
46300 REM amplitude by less than 1mV, or if the algorithm has been repeated
46400 REM 10 times, exit the routine.
46500 REM 9. Otherwise, multiply the XTAL2 amplitude by (beta) and feed it
46600 REM back to XTAL1, and go back to 5.
46700 REM
46800 REM 1. COMPUTE APPROXIMATE OSCILLATION FREQUENCY.

```

230659-49

```

46900 GOSUB 9700
47000 REM
47100 REM      2. CALL A CIRCUIT ANALYSIS AT THIS FREQUENCY.
47200 GOSUB 20800
47300 PRINT : PRINT : PRINT "ASSUMED OSCILLATION FREQUENCY: "
47400 GOSUB 26600
47500 PRINT : PRINT
47600 REM
47700 REM      3. FIND QUIESCENT POINT
47800 REM (At quiescence the voltages at XTAL1 and XTAL2 are equal. This
47900 REM voltage level is found by trial-and-error, based on the input-
48000 REM output curve, so that a person can change the input-output curve
48100 REM as desired without having to re-calculate the quiescent point.)
48200 VI = 0
48300 VB = 1
48400 K1 = 1
48500 VI = VI + VB
48600 GOSUB 13600
48700 IF ABS(VD-VI)<.001 THEN 49200
48800 IF K1+SGN(VD-VI)=0 THEN 48900 ELSE 48500
48900 K1 = SGN(VD-VI)
49000 VB = -VB/10
49100 GOTO 48500
49200 VB = VI
49300 PRINT "QUIESCENT POINT = ",VB
49400 REM
49500 REM      4. ASSUME AN INITIAL AMPLITUDE FOR THE XTAL1 SIGNAL.
49600 EI = .01
49700 NR% = 0
49800 REM
49900 REM      5. CORRECT FOR CLAMPING EFFECTS, IF NECESSARY.
50000 REM (K1 and K2 are curve-fitting parameters for the ROM parts.)
50100 K1 = (2.5-VB)/(3-VB)
50200 K2 = (VB-1.25)/(3-VB)
50300 IF IC%=2 OR IC%=4 THEN IF EI<(VB+ 5) THEN E0 = VB ELSE E0 = EI - .5
50400 IF IC%=1 OR IC%=3 THEN IF EI<(VB+ 5) THEN E0 = VB ELSE E0 = K1*EI+K2
50500 NR% = NR% + 1
50600 REM
50700 REM      6. DERIVE XTAL2 AMPLITUDE
50800 V0 = 0
50900 VC = 0
51000 VS = 0
51100 FOR N% = -25 TO +24
51200 VI = E0 - EI*COS(PI*N%/25)
51300 GOSUB 13600
51400 V0 = V0 + VD
51500 VC = VC + VD*COS(PI*N%/25)
51600 VS = VS + VD*SIN(PI*N%/25)
51700 NEXT N%
51800 V0 = V0/50
51900 V1 = SQR(VC^2+VS^2)/25*FNZM(RL, XL)/FNZM((RL+RD), XL)
52000 REM
52100 REM      7. CLIP XTAL2 SIGNAL.
52200 IF V0-V1<0 THEN VL = 0 ELSE VL = V0-V1
52300 PRINT : PRINT "XTAL1 SWING = ",E0-EI, " TO ",E0+EI
52400 PRINT "XTAL2 SWING = ",VL, " TO ",V0+V1
52500 REM
52600 REM      8. TEST FOR TERMINATION.
52700 IF ABS(EI-V1*B)<.001 OR NR%=10 THEN RETURN
52800 REM
52900 REM      9. FEED BACK TO XTAL1 AND REPEAT
53000 EI = V1*B
53100 GOTO 50300

```

230659-50

INTEL, SUPPLY FILLER

INTEL, SUPPLY FILLER

INTEL, SUPPLY FILLER



INTEL CORPORATION, 2200 Mission College Blvd., Santa Clara, CA 95052; Tel. (408) 765-8080

INTEL CORPORATION (U.K.) Ltd., Swindon, United Kingdom; Tel. (0793) 696 000

INTEL JAPAN k.k., Ibaraki-ken; Tel. 029747-8511

