

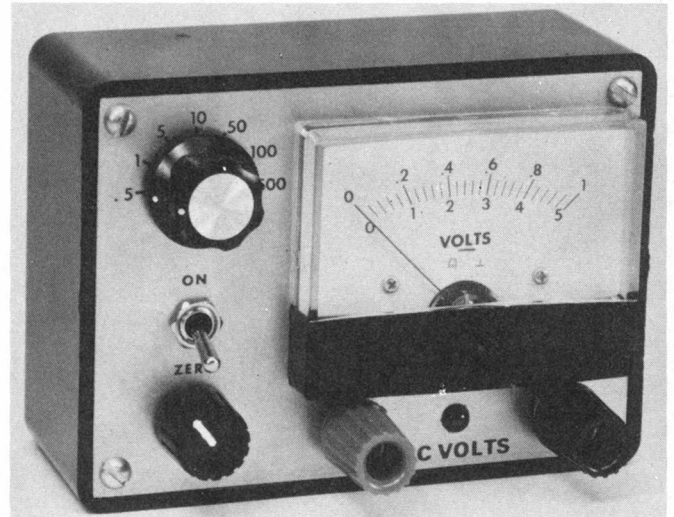

# Some Basics for Equipment Servicing

**Part 2:** Dc voltage measurements are fundamental to troubleshooting amateur equipment. This month we'll look at how to make these measurements and show you a "hi-Z" voltmeter you can build in a weekend.

By George Collins,\* KC1V



In Part 1 of this series we looked at a number of techniques for testing solid-state devices. With these basics under our belts we are ready to address the next question in troubleshooting: "Which components should I check first?" It's an important question. A modern transceiver may contain over 100 solid-state devices; to randomly test each of them would not be productive. We need to zero-in on the defective circuit so that our effort can be concentrated where it will do the most good.

## Where to Look?

The first source of information to consider is the defect itself. If the RIT (receiver incremental tuning) stops working, we wouldn't begin testing transistors in the audio amplifier! Try to gain as much information as possible from the symptoms. "The RIT won't work" is a start, but you should examine the problem in more detail *before* you begin making measurements and testing components. Ask yourself questions. Does the RIT control affect the receive frequency at all?

Does it change both the receive and the transmit frequencies, or does the frequency shift when the RIT switch is turned on, but the variable control fails to function? The answers to questions like these can provide valuable clues in tracking down the guilty component.

Some problems, like the RIT example, are fairly simple to isolate. In this case, the number of components is small, and the settings of other controls (band switch, rf gain and so forth) are not likely to affect the problem. We should have little difficulty locating the circuit and components causing the malfunction. When we encounter more complex problems (Murphy's law indicates that we will!) it is often helpful to make notes of exactly what the symptoms are. Later, when testing has begun, keep notes on what tests have been made and the results.

## Voltage Measurements

One of the fundamental troubleshooting techniques is to check the voltage present at various points in the circuit. The measured voltage is compared with the voltage we *expect* to find at that point. Knowing what to expect is important. If we don't have some idea of what the voltage should be, measuring it won't tell us very much. This is where our

knowledge of the circuit pays off. "Okay, knowing exactly how a circuit works is great, but what if I don't know what to expect?" Remember rule no. 1 from Part 1? Purchase the factory service manual! Generally, the important voltages are shown on the schematic diagram. These values will give us a starting point for our investigation. Unfortunately, not every circuit voltage is given, and sometimes the service manual for a particular rig is unavailable. We must then rely upon our knowledge of how the various devices in the circuit function.

Fig. 1 shows a typical rf amplifier circuit that contains an npn transistor. If we suspect this circuit is malfunctioning, but don't have the circuit voltages, how do we proceed? All we need is Ohm's Law and a few basics about transistors, and we can determine all the important circuit voltages. For example, R1 and R2 form a voltage divider that supplies dc bias to the base of the transistor. To find the value of the base voltage we apply Ohm's Law:

$$E_b = \frac{12 \text{ V}}{10 \text{ k}\Omega + 2.2 \text{ k}\Omega} \times 2.2 \text{ k}\Omega$$
$$= 2.2 \text{ V} \quad (\text{Eq. 1})$$

The voltage at the collector will be nearly

\*Assistant Technical Editor

the supply voltage (12 V) because the voltage drop across L1 (which should have a low dc resistance) will be very small. The voltage at the emitter can also be estimated. For a transistor to act as an amplifier, the emitter-base junction must be forward biased. For an npn transistor, this means that the base must be at a more positive voltage than the emitter. Also, we know that the voltage drop across the junction will be about 0.7 V (for a silicon transistor) when it is forward biased. We have already calculated the base voltage, so the emitter voltage is simply:

$$E_e = E_b - 0.7 \text{ V} = 2.2 \text{ V} - 0.7 \text{ V} = 1.5 \text{ V} \quad (\text{Eq. 2})$$

We now have our "expected values" for the circuit. If we measure the voltages and find that the collector is at a potential of 12 V, the base at 2.5 V and the emitter at 0 V, we know immediately that there is a serious problem. It is likely that the base-emitter junction has opened. Now is the time to remove the transistor and confirm

that it is defective by using the ohmmeter checks described in Part 1.

Before the defective transistor is replaced, it is wise to try to determine the cause of the failure. The base and collector voltages have already been found to be correct so we can eliminate them as the possible cause. With the transistor removed from the circuit, an ohmmeter can be used to check R3 and the 0.1- $\mu$ F bypass capacitor. If a low resistance is found (less than the correct 82- $\Omega$  value for R3), one end of the resistor or capacitor can be disconnected so that the defective component can be isolated. (The capacitor should not provide a resistance reading.

Often the voltages we measure will not agree exactly with our expected values. Small variations are normal and do not mean that the circuit is not operating as it should. Component tolerance and meter errors are the primary causes for these variations. In the npn rf amplifier example we calculated that the base voltage should be 2.2 V. When measured, the value was found to be 2.5 V. Is this too far

from the expected value to be considered within the range of normal variations? Generally, any voltage that is within 15 to 20% of the expected value is acceptable. In our example the measured value differed from the expected value by only:

$$\frac{2.5 \text{ V} - 2.2 \text{ V}}{2.2 \text{ V}} \times 100\% = 13.6\% \quad (\text{Eq. 3})$$

This is within the range of acceptable values and should not cause us any concern.

The same approach can be applied to circuits using JFETs or MOSFETs. As an example, let's look at the MOSFET i-f amplifier shown in Fig. 2. Again, using only Ohm's Law, we can determine approximately what the voltage should be at each point in the circuit. The gate 2 bias voltage is supplied by the voltage divider, R1 and R2. It is:

$$E_{g2} = \frac{12 \text{ V}}{33 \text{ k}\Omega + 100 \text{ k}\Omega} \times 33 \text{ k}\Omega = 3.0 \text{ V} \quad (\text{Eq. 4})$$

The drain potential is simply the supply voltage (12 V), and because it has no dc bias applied to it, gate 1 is at ground (0 V). Determining the exact value of the source voltage requires that we know the drain current under these particular circuit conditions. While this information could be obtained from the transistor data sheet, we don't really need to know the exact voltage. Having an idea of the range of voltages to expect will suffice. The drain current in a typical small-signal FET amplifier, as might be used as an rf or i-f stage in a receiver, will fall between 2 and 17 mA. This range of current will produce a potential of 0.2 to 1.7 V across the 100- $\Omega$  source resistor. Any value between those limits indicates that the circuit is likely to be functioning correctly. If the measured value is far from the expected range, such as 0 or 12 V, one or more of the circuit components is defective. Removing the transistor and testing each component with an ohmmeter will identify the defective part.

### Voltmeter Loading Effects

The circuit in Fig. 2 brings up a problem often encountered when making voltage measurements on circuits using FETs. Because the impedance levels involved with FETs are very high, the bias circuits may require high-value resistors. The difficulty arises when we attempt to measure the bias voltage with a VOM (volt-ohm-milliammeter). A typical VOM will have a sensitivity of 20 k $\Omega$  per volt, while the more sensitive VOMs are rated at 50-k $\Omega$  per volt. The meter sensitivity multiplied by the full-scale voltage of the meter gives the impedance or resistance of the meter. A 50-k $\Omega$ -per-volt meter, used

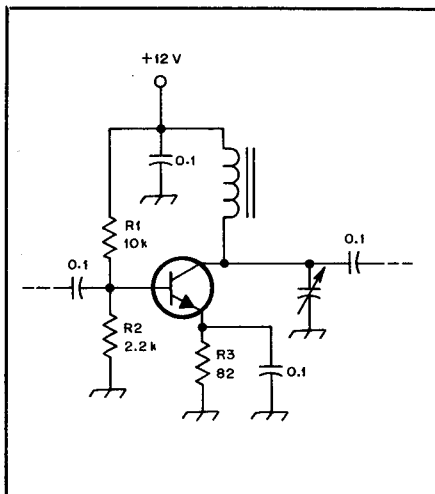

Fig. 1 — Schematic diagram of a typical rf amplifier. Circuits similar to this one are commonly found in transmitters and receivers.

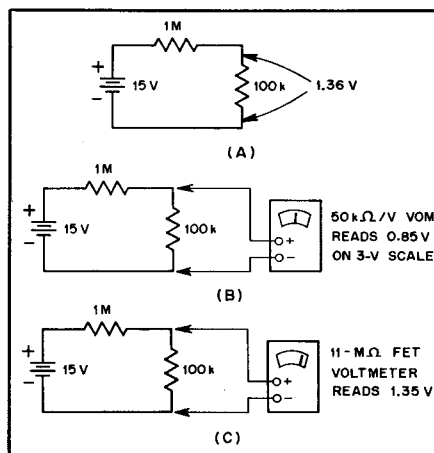

Fig. 3 — The circuit at A is a high-impedance voltage divider. Using a standard VOM (B) results in a 37% error because of meter loading. An 11-M $\Omega$  meter does not load the circuit appreciably; the error is less than 1% (C).

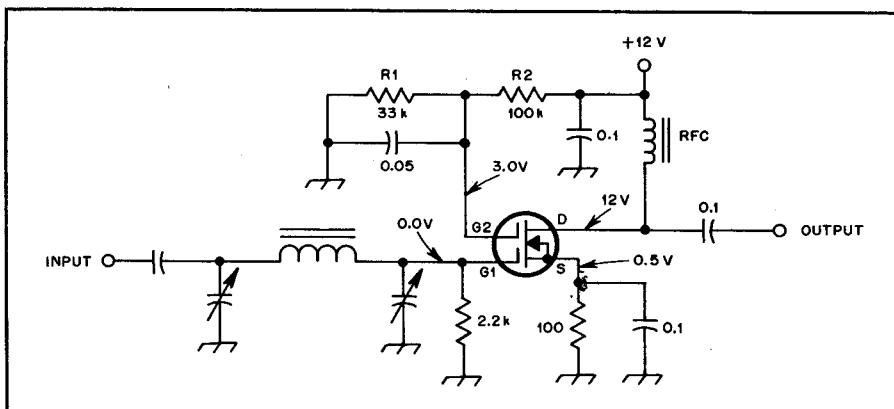

Fig. 2 — Another common rf amplifier circuit uses a MOSFET. Troubleshooting this type of circuit is discussed in the text.

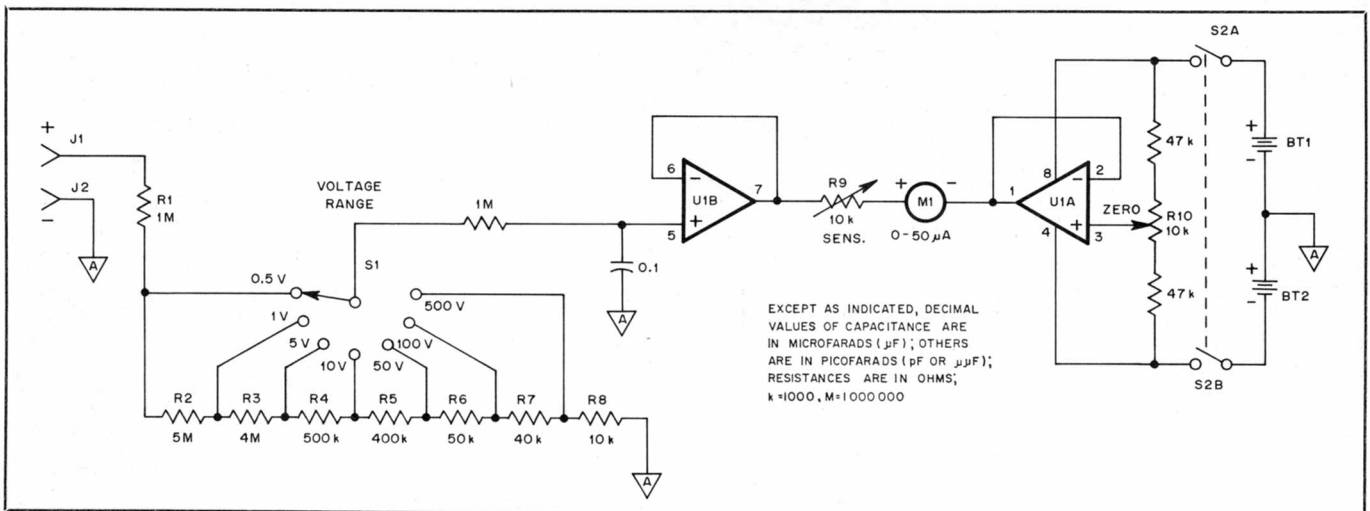

Fig. 4 — A high-impedance dc voltmeter need not be complex. This circuit uses a single IC.

BT1, BT2 — 2 AAA (or AA) cells in holder or 9-V transistor radio battery (see text).  
 J1, J2 — Banana jacks, 500-V insulation (see text), RS 274-662 or equiv.  
 M1 — 50-μA dc meter movement, RS 270-1751.  
 U1 — LF353N dual JFET op amp, RS 276-1715 or equiv.  
 R1 — 1.0-MΩ, 1/2-W, 5% resistor.  
 R2 — 4.7-MΩ and 300-kΩ, 1/4-W, 5% resistors

in series.  
 R3 — 3.9-MΩ and 100-kΩ, 1/4-W, 5% resistors in series.  
 R4 — 470-kΩ and 30-kΩ 1/4-W, 5% resistors in series.  
 R5 — 390-kΩ and 10-kΩ 1/4-W, 5% resistors in series.  
 R6 — 47-kΩ and 3-kΩ, 1/4-W, 5% resistors in series.  
 R7 — 39-kΩ and 1-kΩ 1/4-W, 5% resistors in series.

R8 — 10-kΩ, 1/4-W, 5% resistor.  
 R9 — 10-kΩ, 1/4-W PC-mount potentiometer, RS 271-218 or equiv.  
 R10 — 10-kΩ, panel-mount potentiometer, RS 271-1722.  
 S1 — 1-pole, 7-position rotary switch (see text), RS 275-1385 or equiv.  
 S2 — 2-pole, 2-position toggle switch, RS 275-614 or equiv.

on the 3-V (full-scale) range, for example, has an impedance of:

$$50 \text{ k}\Omega/\text{V} \times 3 \text{ V} = 150 \text{ k}\Omega \quad (\text{Eq. 5})$$

This resistance is placed in parallel with the circuit resistance whenever we make a measurement. Often (when the circuit resistance is much lower than the meter resistance) it is unimportant, but when dealing with high-impedance devices like FETs we must be aware of the effects of meter "loading." Fig. 3 shows the type of error that can be caused by using even a 50-kΩ-per-volt VOM in a high-impedance circuit. If a high-impedance meter, such as an FET or vacuum-tube voltmeter, is used (Fig. 3C) the error caused by meter loading becomes very small.

This does not mean that a standard VOM is useless. For many measurements they serve well. They are versatile and, most important, inexpensive. While high-impedance (11-MΩ) VOMs are available, even the lowest-priced units are somewhat costly. By building our own FET voltmeter we can circumvent the high cost of a commercial meter and have some fun at the same time!

#### A "Weekender" FET Voltmeter

Shown in Fig. 4 and the photographs is an easy-to-build, high-impedance dc voltmeter. All of the parts are readily available, calibration is simple and the cost is low. Construction of this meter can be considered as an easy weekend project. The input-impedance is 11 MΩ, and accuracy is better than 10%. With the rf

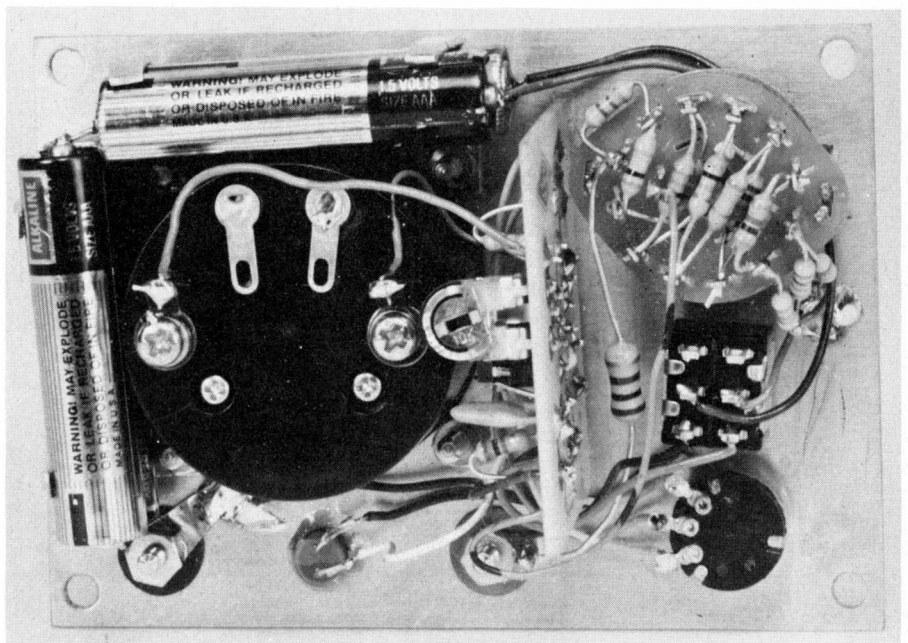

Inside view of the dc voltmeter. This version was built from an available parts kit. Other components and construction styles can be used as well.

probe shown in Fig. 5, this meter can be used to make reasonably accurate rf voltage measurements at frequencies up to 30 MHz.

#### Circuit Details

The input impedance of the meter is determined by the total resistance of the range-selector voltage divider (R1 through

R8). The values of the individual resistors have been selected to provide the desired full-scale voltage ranges and a total resistance of 11 MΩ. Some of the resistance values needed for the divider are not found in the standard series of 5%-tolerance resistor values. To avoid having to buy expensive (and hard to find) 1% resistors, two 5% units are used in

For more information on op amps see G. Woodward, "A Beginner's Look at Op Amps," QST, April and June 1980, pp. 15-18 and 25-31. Anyone interested in learning more about op amps should consider these articles required reading. Printed-circuit boards and parts for the voltmeter and probe are available from Circuit Board Special-ist, P.O. Box 969, Pueblo, CO 81002.

Notes

Only the sensitivity control, R9, needs to be adjusted before the meter can be used. A good method of calibration is to use two fresh carbon-zinc batteries in series to form a source of known potential. Each cell, when new, should produce 1.54 V. To adjust R9, turn the meter on, and set it to the 5-V range. With the meter leads shorted together, adjust the ZERO control (R10) so that meter shows zero volts. Connect the two cells to the meter, and adjust R9 so that the meter reads 3.1 V. This completes the voltmeter, and it is ready to use in your experiments or to troubleshoot the rig next time it develops a problem.

Calibration

With the resistor values shown in Fig. 4, the highest full-scale range is 500 V. If this range is included, be sure that the input connectors (J1 and J2) and the range switch (S1) are rated for 500 V or more. J1 and J2 should be of the type with plastic insulation that passes through the panel. Only thin, fiber washers are used to insulate some types of jacks from the panel. These are fine for up to 100 V, but are not recommended for higher voltages. If the 500-V range is not needed, R7 and R8 can be connected in series or replaced by a 50-k $\Omega$  resistor (the same as R6). The rf probe should be housed in a shielded case. Copper or brass hobby tubing of 1/2-inch diameter is good for this purpose. The cable from the probe to the voltmeter should be shielded. The shield braid is connected to the probe case and the ground lead. Small-diameter coaxial cable, such as RG-174/U, can be used for this lead.

The Radio Shack 270-1751, an enclosure measuring 2-5/8" x 5-1/6" x 1-5/8" inches will be more satisfactory. When using a case with a metal panel, it is best if the negative jack (J2) is not connected to the panel. This allows us to measure voltages below ground without having a potential on the voltmeter case. The voltage-divider resistors are mounted on the range selector switch (S1). If the switch has any spare lugs, they can be used as tie points for the series-connected resistors. If no lugs are available, simply solder the leads together; the remaining leads will support the resistors. The other components can be mounted on a small printed-circuit board, although any method of wiring can be used. A quick and simple way of wiring the IC is to use a general-purpose IC-prototyping board, such as the Radio Shack 276-159.

With the resistor values shown in Fig. 4, the highest full-scale range is 500 V. If this range is included, be sure that the input connectors (J1 and J2) and the range switch (S1) are rated for 500 V or more. J1 and J2 should be of the type with plastic insulation that passes through the panel. Only thin, fiber washers are used to insulate some types of jacks from the panel. These are fine for up to 100 V, but are not recommended for higher voltages. If the 500-V range is not needed, R7 and R8 can be connected in series or replaced by a 50-k $\Omega$  resistor (the same as R6). The rf probe should be housed in a shielded case. Copper or brass hobby tubing of 1/2-inch diameter is good for this purpose. The cable from the probe to the voltmeter should be shielded. The shield braid is connected to the probe case and the ground lead. Small-diameter coaxial cable, such as RG-174/U, can be used for this lead.

Almost any type of case can be used to house the voltmeter. The exact size needed will depend on the dimensions of the battery, meter movement and switches used. A plastic case, only 2-7/8" x 4" x 1-5/8"-inches (mm = in. x 25.4) houses the meter shown in the photographs. If a larger meter movement is used (such as

the front panel so that the operator can adjust it easily. R9 is the calibration control; it adjusts the meter sensitivity. Once the meter has been calibrated, R9 does not require further adjustment, so it is mounted inside the case. Two batteries are used to power the meter circuit. Any battery voltage between 3 and 9 V can be used without changes in the circuit. In the unit shown, four AAA penlight cells are used. These give the needed 3 V and have long life. Two 9-V transistor radio batteries will also work.

Construction

Two batteries are used to power the meter circuit. Any battery voltage between 3 and 9 V can be used without changes in the circuit. In the unit shown, four AAA penlight cells are used. These give the needed 3 V and have long life. Two 9-V transistor radio batteries will also work.

Two batteries are used to power the meter circuit. Any battery voltage between 3 and 9 V can be used without changes in the circuit. In the unit shown, four AAA penlight cells are used. These give the needed 3 V and have long life. Two 9-V transistor radio batteries will also work.

Fig. 6 — Parts-placement diagrams for the dc voltmeter (A) and the rf probe (B).

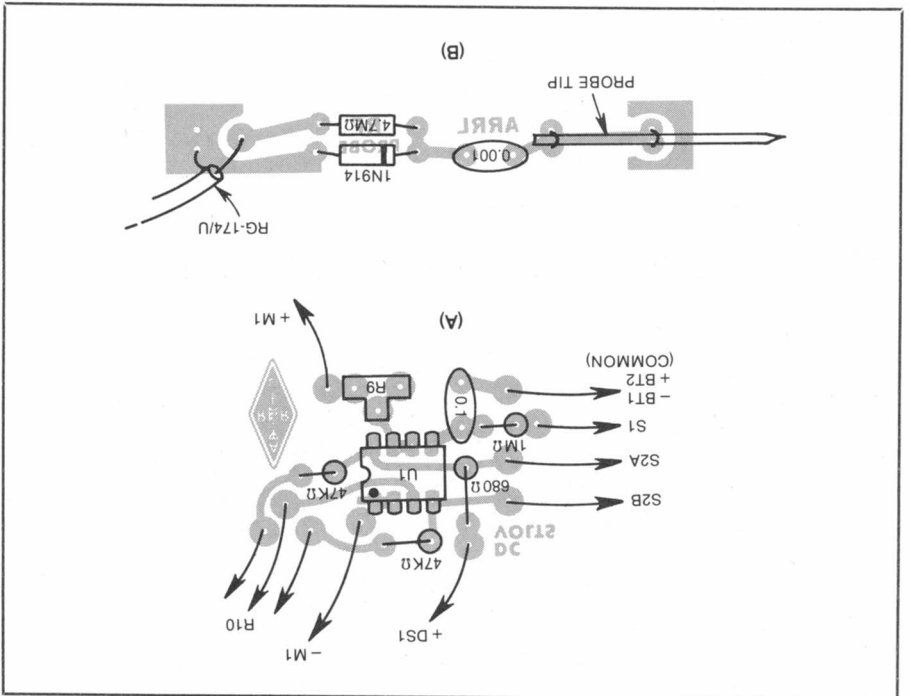

Fig. 5 — When used with an 11-M $\Omega$  voltmeter, this rf probe will allow you to measure voltages at frequencies up to 30 MHz. The maximum rf voltage applied to this probe should be limited to 35.

