

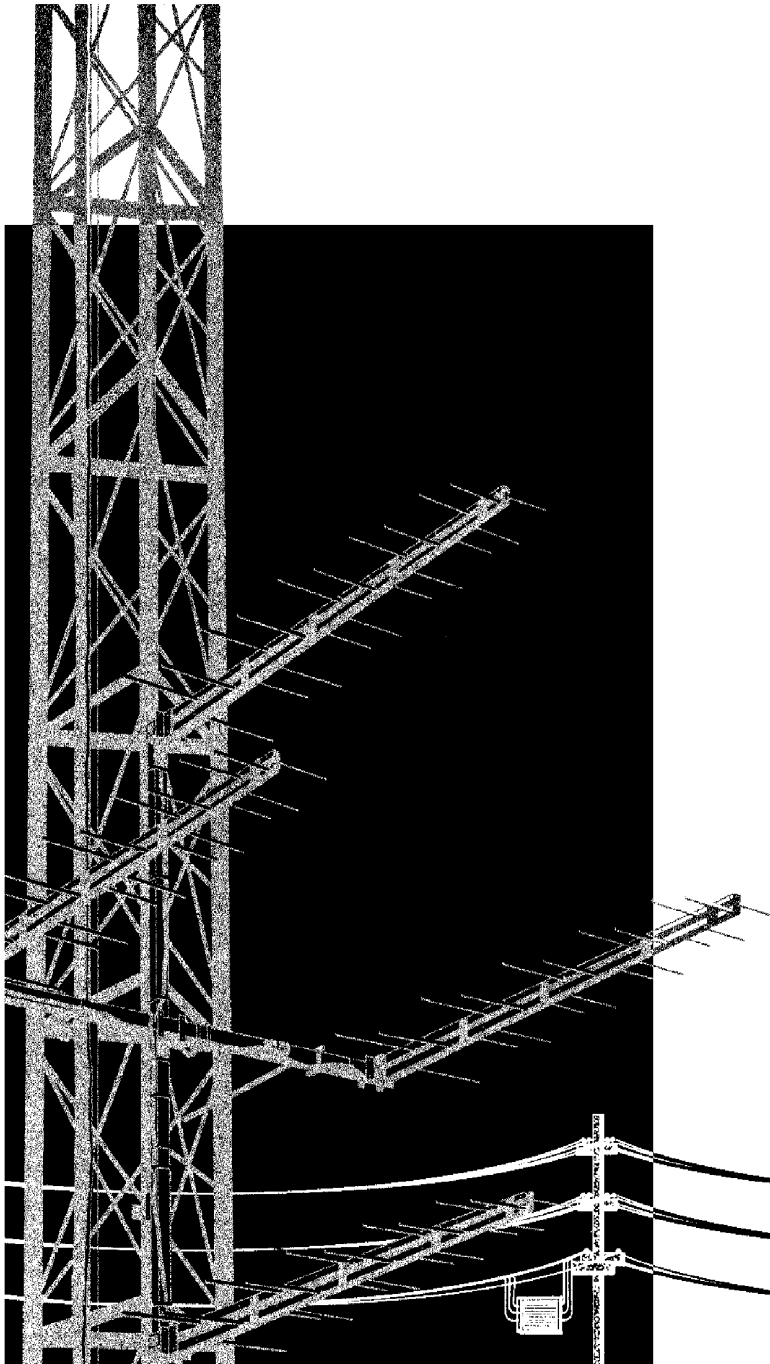
---

# Cable Television System Measurements Handbook

## NTSC Systems

---

February 1994



# Cable Television System Measurements Handbook

NTSC Systems

---

February 1994



# Table of Contents

<b>Chapter 1. TV Signal and CATV Distribution</b>	
TV Broadcast Signal .....	1-1
The Cable Television Distribution System .....	1-4
<b>Chapter 2. Measurement Parameters</b>	
Signal Frequency .....	2-2
Signal Level .....	2-4
Noise .....	2-9
Interference .....	2-15
Ingress and Co-Channel Interference .....	2-15
Low Frequency and Coherent Disturbances .....	2-15
Measuring Distortion .....	2-19
Channel Frequency Response .....	2-20
Depth of Modulation .....	2-21
System Frequency Response .....	2-23
Interference Outside the System .....	2-23
In Summary .....	2-26
<b>Chapter 3. Test Instrumentation</b>	
Network and Signal Analysis .....	3-1
Instrumentation .....	3-1
In Summary .....	3-6
<b>Chapter 4. Performance Measurements with a Spectrum Analyzer</b>	
Absolute and Relative Measurements .....	4-1
Accuracy Considerations .....	4-2
Suggested Equipment .....	4-2
Before you Start .....	4-3
Full System Check .....	4-4
Visual and Aural Carrier Level and Frequency .....	4-4
Measuring C/N with the Spectrum Analyzer .....	4-7
Corrections Required to Measure Noise Power Density .....	4-7
Measuring and Calculating Carrier to Noise .....	4-10
Computing C/N .....	4-11
Quick Look C/N Measurement .....	4-12
Co-Channel and Ingress Interference .....	4-13
Low Frequency Disturbances (Hum) .....	4-15
Coherent Disturbances: CSO and CTB .....	4-17
Crossmodulation .....	4-19
In-Channel Frequency Response .....	4-20
Using Program Video and VITS .....	4-22
Depth of Modulation .....	4-25
System Frequency Response .....	4-27
<b>Appendix A. Reference Tables</b> .....	A-1
<b>Appendix B. Glossary</b> .....	B-1
<b>Appendix C. Index</b> .....	C-1

## **INTRODUCTION**

At the time of the first edition of this handbook (1977) the number of cable television systems was growing rapidly and regulations were being enforced. Growth has not abated. With over 10,000 systems in North America, both subscriber base and the channels per system continue to grow. Then, as now, these pressures require system maintenance and testing with increased efficiency. Better test equipment helps. So does your understanding of the measurement principles.

This handbook refreshes the measurement concepts and updates the use of the modern spectrum analyzer for making proof-of-performance measurements.

February 1994

# Chapter 1

## TV Signal and CATV Distribution

This chapter reviews the signal and distribution methods used in cable television systems as background for instrumentation and measurement discussions that follow.

---

### TV Broadcast Signal

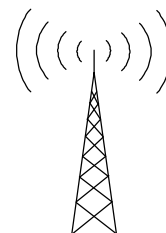
The television broadcast signal, whether it be NTSC, PAL or SECAM, is the most complex signal used in commercial communications; comprised of amplitude, frequency, phase and pulse modulation fitted into a 6 MHz channel with a single sideband transmission process called *vestigial sideband*.

Figure 1.1 shows the relationship of the RF carrier's modulation to a TV raster. The numbers relate to the NTSC standard, but the methods apply to PAL and SECAM as well. In Figure 1.1(a), the amplitude modulation is shown as an envelope on the RF carrier, symmetrically about a zero voltage amplitude. When a TV receiver looks at this carrier, it picks off only the envelope and discards the RF carrier. Figure 1.1(b) expands a portion of this envelope to show the vertical scan as frame sync pulse. The square sync pulse provides bursts of RF energy at the peak carrier amplitude. This repetitive burst synchronizes vertical scan on the TV receiver at a 59.94 Hz rate (60 Hz for B/W).

Figure 1.1(c) is a 1:100 time domain magnification of the waveform in Figure 1.1(a). It shows the horizontal sync pulses and luminance information on two of the 525 horizontal lines that make up a single frame. These sync pulses, which run at a 15,734.264 Hz rate, also have their tops at the peak RF carrier level. For color transmission this pulse includes a 3.579545 MHz burst on its trailing side, or "back porch." This burst of 3.58 MHz is still an amplitude modulation envelope of the carrier; that is, for the duration of the burst the amplitude of the RF carrier increases and decreases at a 3.58 MHz rate.

Figure 1.1(d) shows the TV picture that results from these amplitude modulation (AM) signals. The area not viewed by a TV receiver is also shown in the figure. The horizontal black bar at the bottom of the screen, the vertical interval, usually contains test signals used by the broadcast system for on-line performance tests that will not interfere with the regular programming.

The audio information in a TV channel is a frequency modulated carrier placed 4.5 MHz above the visual carrier at less than 1/8 of its power. Figure 1.1 (a) doesn't show the aural carrier. The aural signal frequency modulates onto the RF carrier, thus becoming its sideband.



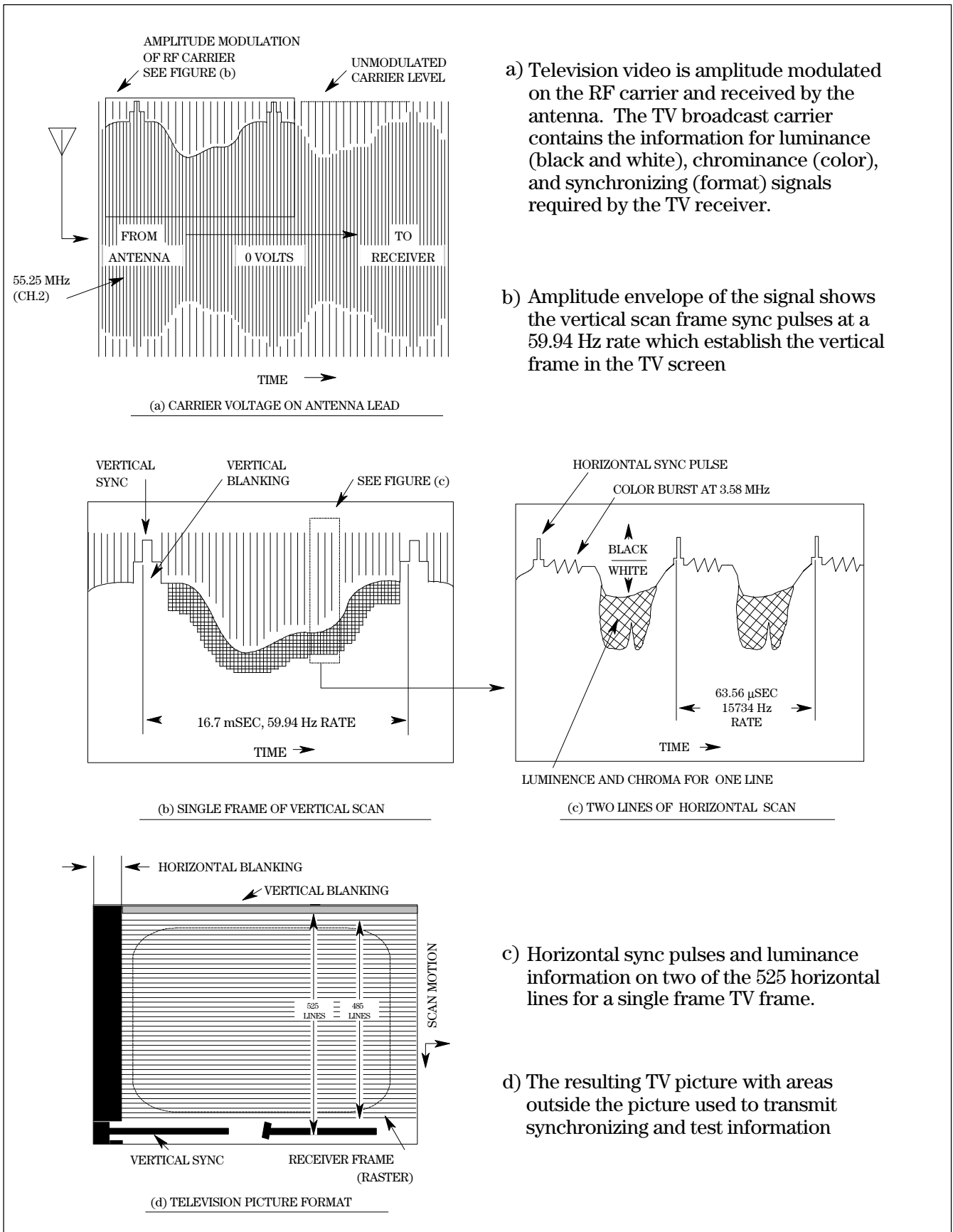
---

**WAVEFORM MONITOR  
READS SIGNAL  
ENVELOPE**

**59.94 Hz RATE  
(60 Hz FOR BW)**

**MOST OF THE ENERGY  
IS IN THE SYNC  
PULSES**

**TV = VIDEO + AUDIO  
+ COLOR**



a) Television video is amplitude modulated on the RF carrier and received by the antenna. The TV broadcast carrier contains the information for luminance (black and white), chrominance (color), and synchronizing (format) signals required by the TV receiver.

b) Amplitude envelope of the signal shows the vertical scan frame sync pulses at a 59.94 Hz rate which establish the vertical frame in the TV screen

c) Horizontal sync pulses and luminance information on two of the 525 horizontal lines for a single frame TV frame.

d) The resulting TV picture with areas outside the picture used to transmit synchronizing and test information

Figure 1.1. TV broadcast carrier modulation parameters for NTSC standards.

Figure 1.1 shows the broadcast signal in the time domain, as on an oscilloscope. Additional information is available with a display of the signal's amplitude versus *frequency* instead of time. Such a display is called the *frequency domain* or *frequency spectrum*.

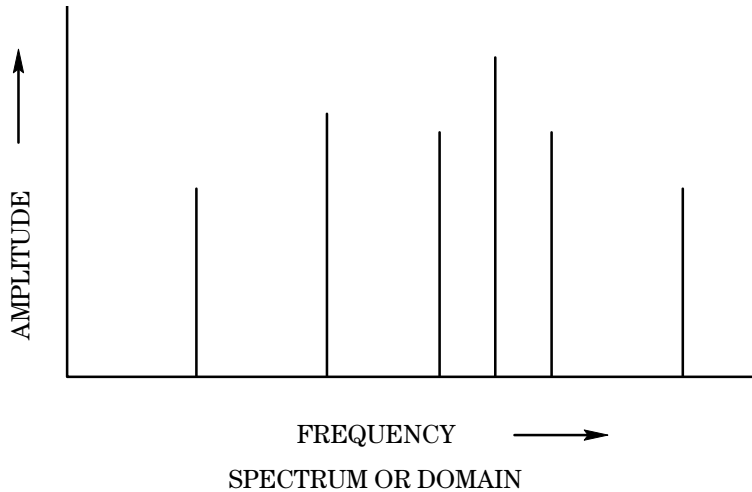
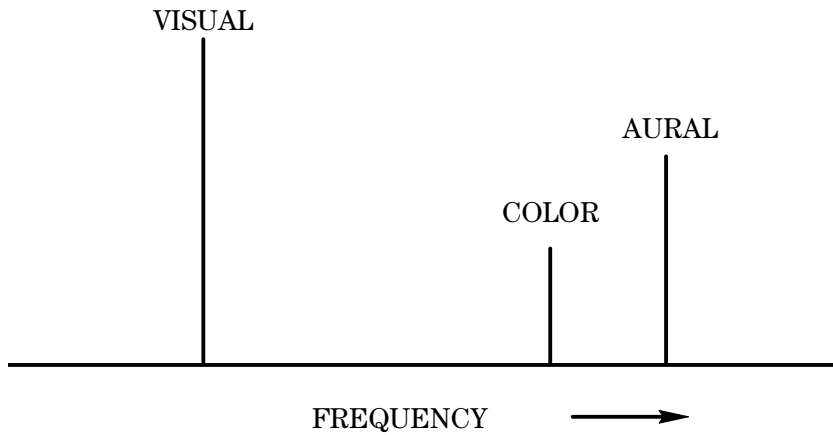


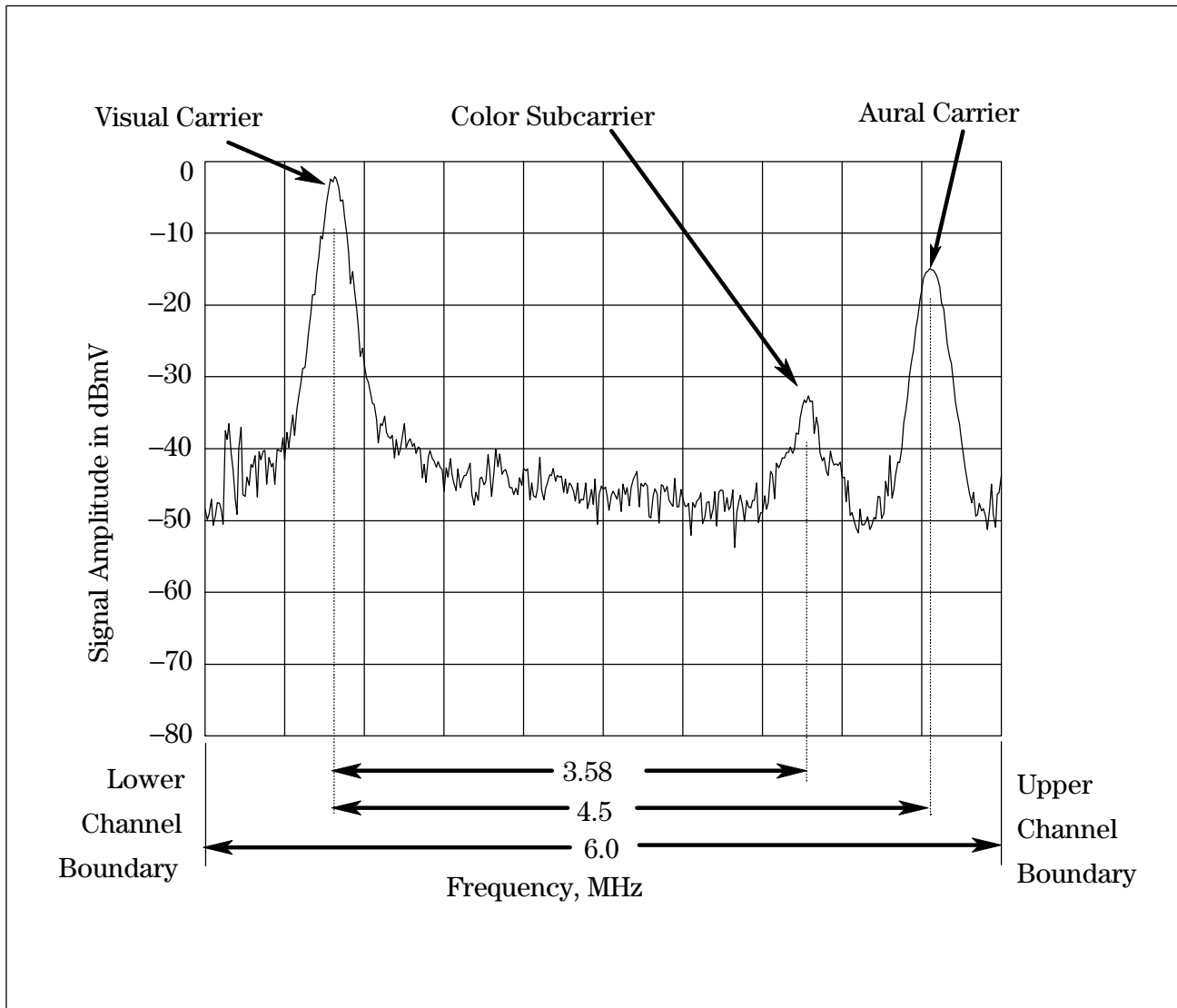
Figure 1.2 shows a frequency domain display of a single TV channel. The vertical axis is scaled to the power of the signal, in units relative to a millivolt. (Chapter 2 covers units and power.) The modulation shown in Figure 1.1 in the time domain is now shown in the frequency domain. Since the visual signal contains most of the transmitted power including aural and color information which is modulated onto it, it is the *carrier*. The sidebands generated would be symmetrical to the carrier except that, on the lower frequency side (to the left of the carrier), the sidebands beyond 0.75 MHz are trapped, or filtered, prior to transmission. This *vestigial sideband* technique is used to conserve frequency spectrum. The TV receiver uses the full upper sideband and the appended lower sideband to reconstruct the TV video.

**THE VISUAL SIGNAL IS THE CARRIER**



The color burst is 3.579545 MHz, or 3.58 MHz, above the carrier. This signal contains the picture's color or chroma signal. Each horizontal sync pulse has a 3.58 MHz burst to calibrate the TV receiver's color circuitry for each horizontal line. The color information is phase modulated.





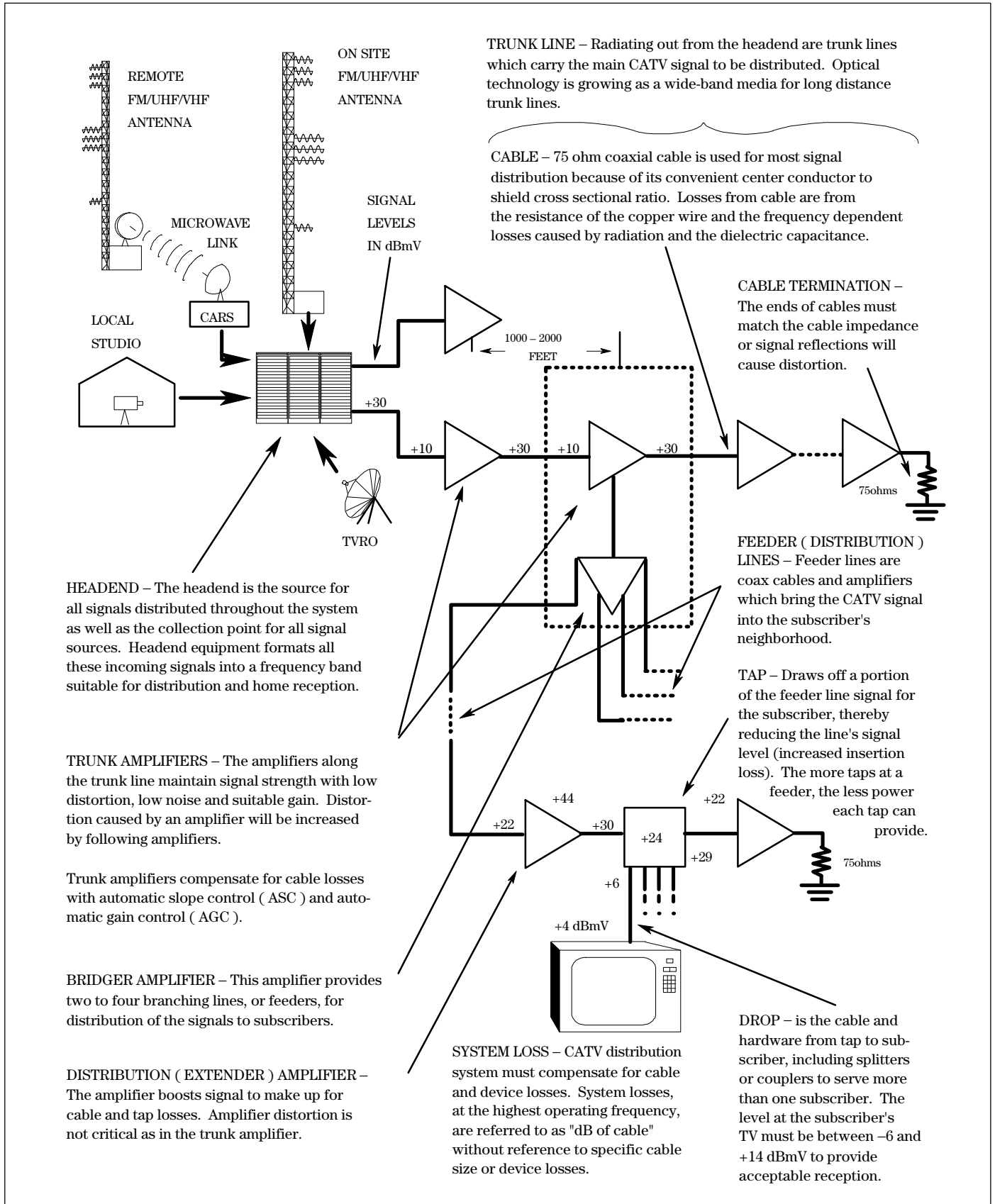
**Figure 1.2.** In the frequency spectrum, the TV channel energy separates into its major signal components.

The aural carrier is placed 4.50 MHz above the visual carrier (or 250 kHz from the upper edge of the channel). It is an FM signal with a 50 kHz bandwidth.

## The Cable Television Distribution System

Early television cable distribution systems were established to serve communities where a majority of the residents could not receive over-the-air programming because of geographical interference. The term CATV, for community antenna television, has long since been extended to mean any region wired for the reception of broadcast programming, whether or not good residential antenna reception is available. Subscribers to these systems generally pay a monthly fee for the service, which usually includes increased channel selection, for-pay and locally originated programming.

**CATV = COMMUNITY  
→ CABLE TV**



**Figure 1.3.** A typical CATV coaxial distribution system with signal levels in dBmV given along one complete distribution branch.



# Chapter 2

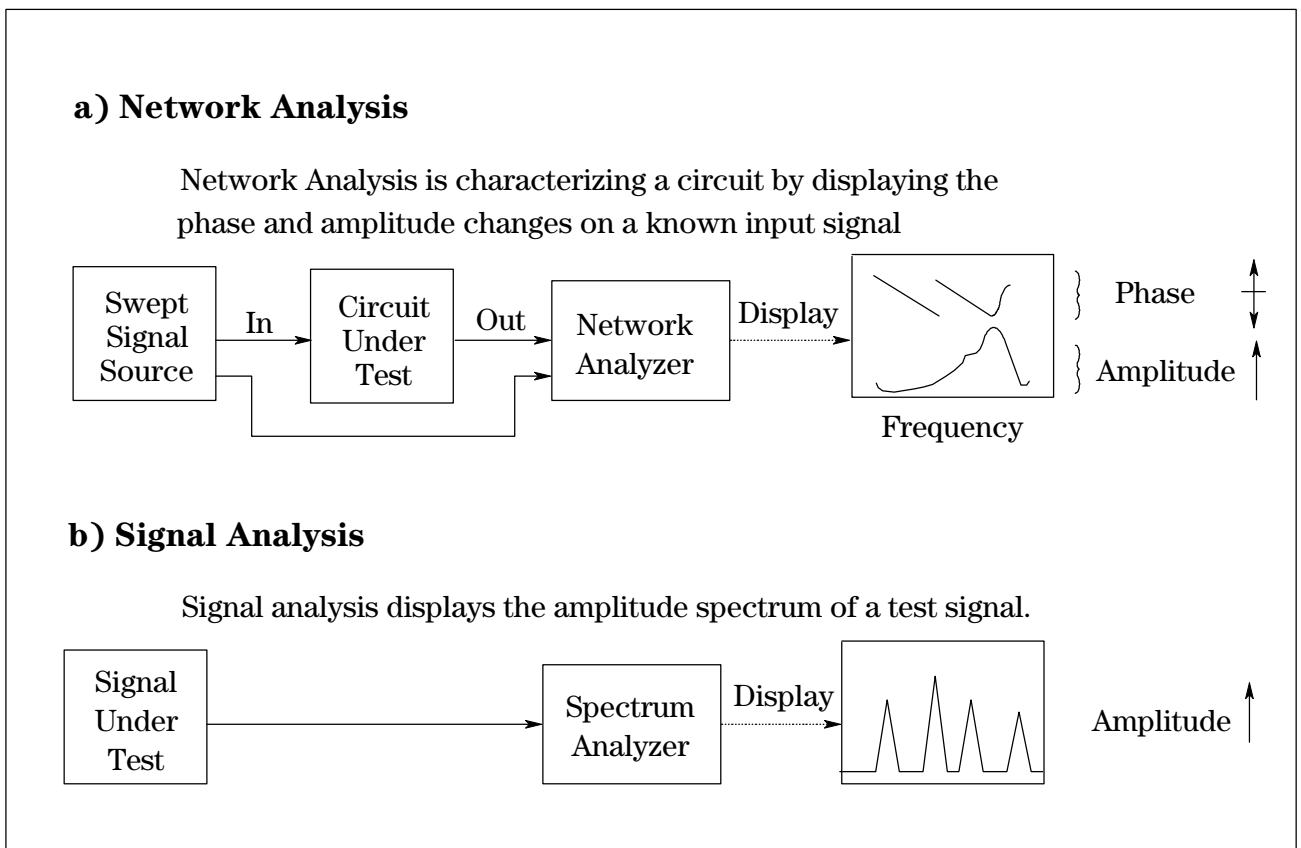
## Measurement Parameters

Service and repair of faulty equipment is one important aspect of the operator's distribution system responsibilities. The other is preventive maintenance, the so called "proof-of-performance" testing which qualifies a system for governmental agency approval.

For a complete understanding of proof-of-performance measurements, let's take an overview of electronic measurement techniques. Whether the electronics is a circuit board in a trunk amplifier or an entire distribution system, it can be thought of as a black box with one or more connectors for access.

Two approaches can be taken to determine how this mysterious black box functions. First, monitor each of the connectors while the box performs in its normal capacity. Or, secondly, feed a known signal in one connector and compare this signal very accurately with the output at another connector. The first procedure is called *signal analysis*. The second, because it tells specifically how much the black box circuit changes a signal, is called *network analysis*. See Figure 2.1.

**ALL MEASUREMENTS  
ARE EITHER OF SIGNALS  
OR OF NETWORKS**



**Figure 2.1.** Network analysis and signal analysis are techniques for analyzing the behavior of electronic circuits.

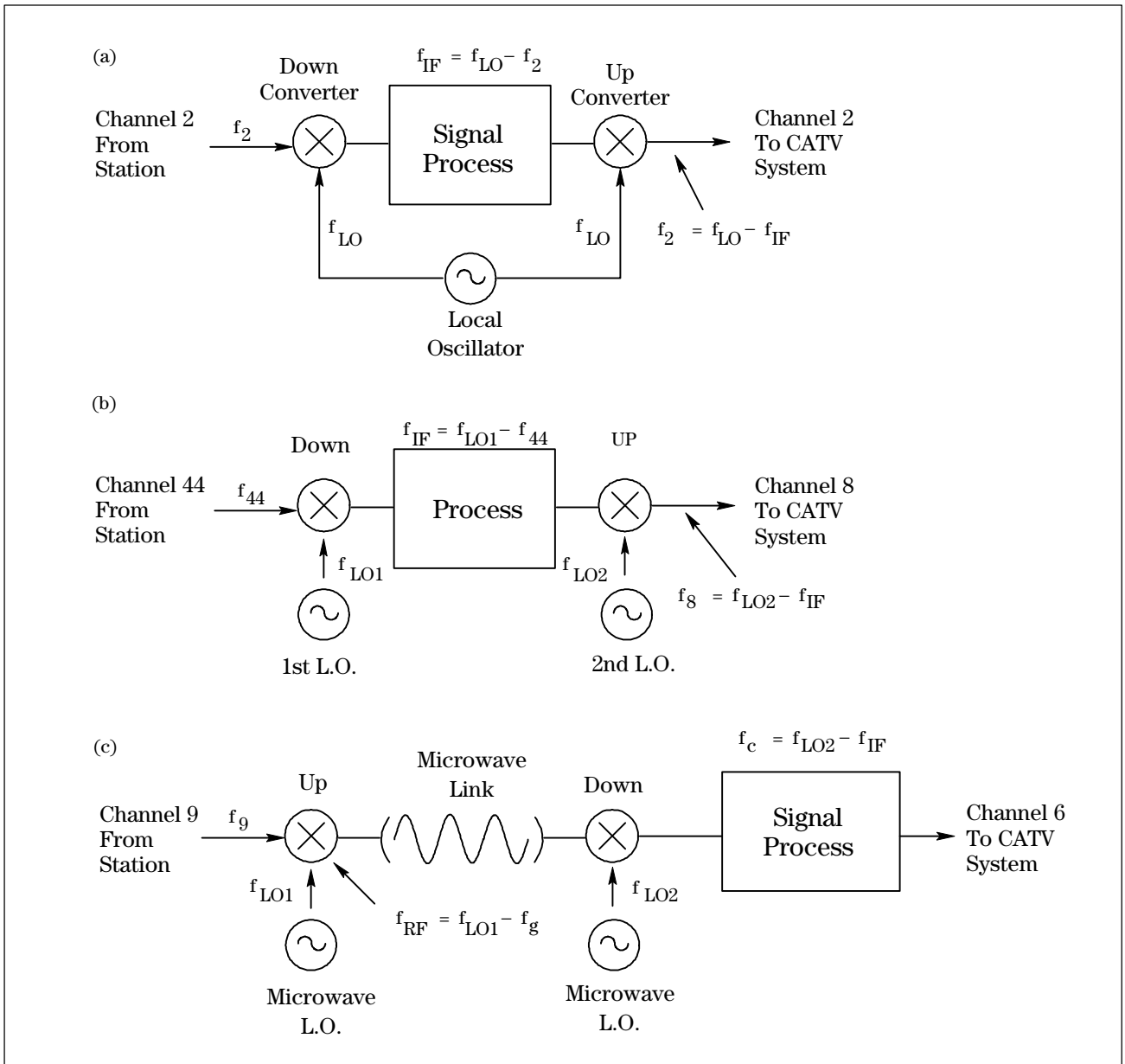


hours, which means for a carrier,  $f_c$ , the frequency change,  $\Delta f_c$ , will be less than

$$\pm \frac{100}{10^6} \times f_c \text{ Hz (where } f_c \text{ is in Hz)}$$

in 12 hours.

For the measurement of frequencies whose accuracy and stability are suspect, the measurement instrument should have at least a factor of 3 better frequency accuracy and stability than the spec. In your CATV system, such an instrument could pinpoint carrier and pilot inaccuracies, assure correct channel and sideband spacing, and identify unwanted signals that may be interfering with the system.



**Figure 2.2.** Frequency accuracy and stability of the broadcast signal in a CATV system depends upon the number and type of frequency conversions it goes through.

**FREQUENCY  
MEASUREMENT  
REQUIRES 3X BETTER  
ACCURACY AND  
STABILITY**

Figure 2.2 shows three typical conversion schemes to illustrate where errors could be introduced. a) IF signal processing using the same LO to reconvert the signal into its original channel cannot introduce frequency error since input and output conversions are not independent. b) When a channel is converted to another slot, the two conversions are independent and a deviation in either LO will show up as a change in output frequency. c) A similar situation exists in this simplified microwave relay conversion process where the two LOs are independent. The microwave LOs must maintain the same absolute frequency accuracy required of UHF/VHF LOs in order to preserve conversion accuracy. In percent accuracy the microwave LO must be considerably better.

## Signal Level

Throughout your CATV system, power is distributed in the form of TV and FM carriers, pilot tones, test signals, DC power supply, and noise. Specified levels must be maintained at each point in the system to assure good performance. The signal levels at different frequencies are just as important. Here is how they are measured.

Let's start with the cable. The **characteristic impedance** of distribution cable is 75 ohms. This impedance is the amount of resistance that the cable signals "see" from the center conductor to the outer shield of the cable at the transmission frequencies. All of the signal voltage and currents travelling the cable are governed by this impedance simply by the familiar Ohm's law. The rms voltage on the cable is related to the power transmitted by

$$P = \frac{V^2}{R} = \frac{V^2}{75}$$

where  $P$  = signal power in watts

$V$  = signal voltage, volts rms

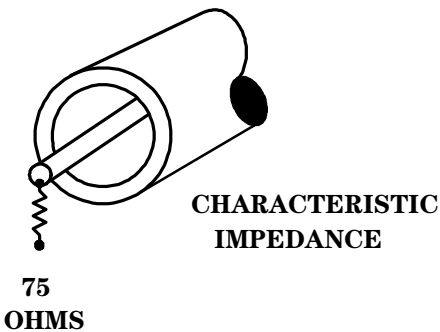
$R$  = cable impedance, ohms

Most CATV system measurements involve signal power differences, that is a level relative to another. Voltage differential is an awkward measure of power differential because each time a power change is measured, the formula  $(V_1^2 - V_2^2) / 75$  has to be calculated.

The **decibel** resolves these difficulties in handling system power figures. It is defined as

$$\text{dB} = 10 \log_{10} \frac{P_2}{P_1}$$

where dB = decibel,



$\frac{P_2}{P_1}$  = ratio of two powers, and  $P_1$  usually the reference

Since  $P_1 = \frac{V_1^2}{75}$  and  $P_2 = \frac{V_2^2}{75}$  the dB can be expressed

as a ratio of voltages

$$\text{dB} = 10 \log \frac{V_2^2/75}{V_1^2/75} = \frac{V_2^2}{V_1^2} = 20 \log \frac{V_2}{V_1}$$

where  $\frac{V_2}{V_1}$  = ratio of two voltages

## **A dB IS A CONVENIENT UNIT FOR POWER MEASUREMENT**

If  $V_1$  is defined as the reference and set equal to 1 mV ( $10^{-3}$  volts) then the dB can be called a "decibel referred to one millivolt" or dBmV.

$$\text{dBmV} = 20 \log \frac{V}{10^{-3}}$$

Note that the characteristic impedance doesn't show in the formula, and it need not as long as the computations are for powers and voltages in the same impedance system. Here are some examples of converting voltage to dBmV:

$$1 \text{ volt} = 20 \log \frac{1}{10^{-3}} = 60 \text{ dBmV}$$

$$0.1 \text{ volt} = 20 \log \frac{10^{-1}}{10^{-3}} = 40 \text{ dBmV}$$

$$0.01 \text{ volt} = 20 \log \frac{10^{-2}}{10^{-3}} = 20 \text{ dBmV}$$

$$10 \text{ } \mu\text{volts} = 20 \log \frac{10^{-5}}{10^{-3}} = -40 \text{ dBmV}$$

Table A.1 located in Appendix A, page A-1, illustrates impedance conversions. Two other units commonly used to measure RF power are dBm and dB $\mu$ V, dB above a milliwatt ( $10^{-3}$  watts) and dB above a microvolt ( $10^{-6}$  volts) respectively. Table A.2, located in Appendix A, page A-2, describes the conversion from each unit to the other.

A change in dB level relates to a change in power. A dB change, no matter what unit referred to ( $\mu$ V, mV or milliwatt), denotes the same power change. A 3 dB increase (or decrease) in a signal level means the power has doubled (or halved). This relation is from the dB power definition.



$$\text{dB} = 10 \log \frac{P_2}{P_1} = 20 \log \frac{V_2}{V_1}$$

$$3\text{dB} = 10 \log 2$$

Table 2.1. is generated from the equations to help you get a "feeling" for the relationship of dB to power-ratio. To derive other power ratios, simply add the combination of dB from the left column and multiply the corresponding ratios in the right column.

To find the voltage for this table let:

$$\frac{V_2}{V_1} = \sqrt{\frac{P_2}{P_1}}$$

dB	$P_2/P_1$	dB	$P_2/P_1$
Add	Multiply	Add	Multiply
0	1	-1	0.8
1	1.25	-3	0.5
3	2	-6	0.25
5	3.16	-9	0.125
6	4	-10	$10^{-1}$
9	8	-20	$10^{-2}$
10	10	-30	$10^{-3}$
20	100		
30	1000		

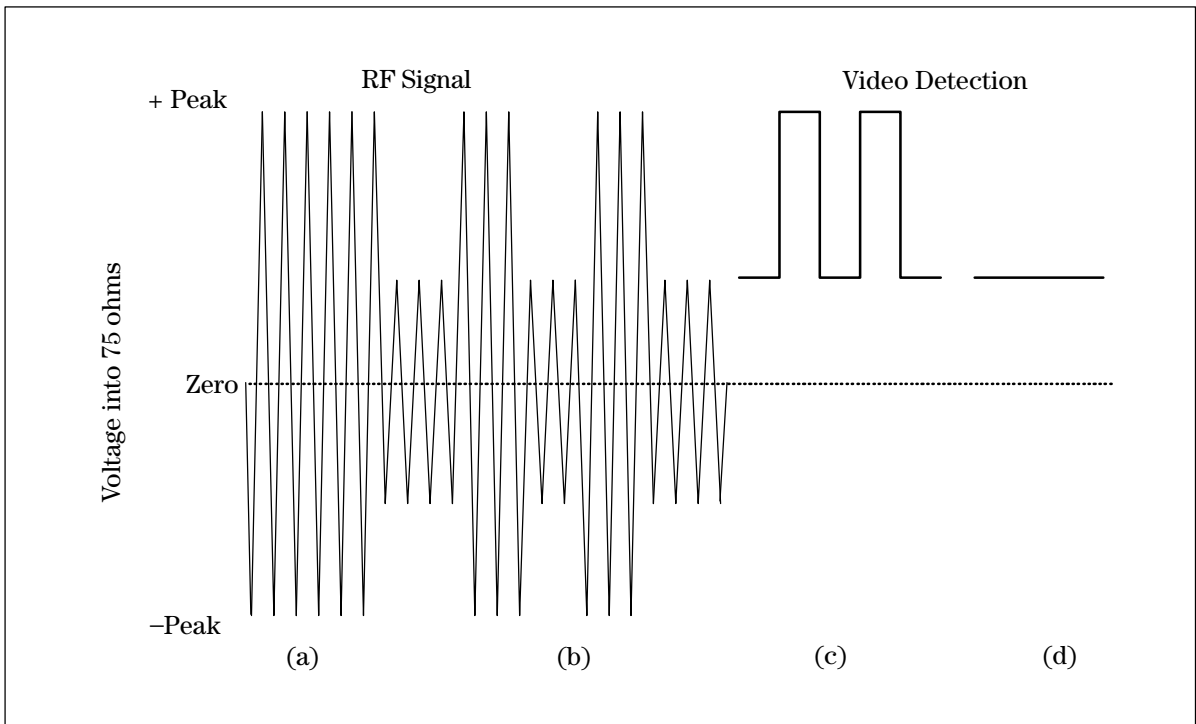
**Table 2.1.** Power Ratios

*Example: What is the power ratio for 24 dB? 24 dB = 20 dB + 3 dB + 1 dB, multiplying the corresponding ratios 100 x 2 x 1.25 = 250. What is the power ratio for -15 dB? -15 dB = -10 -6 + 1 dB so multiplying  $10^{-2} \times 0.25 \times 1.25 = .03$ . A similar table and computation can be made for the dB/voltage relationship.*

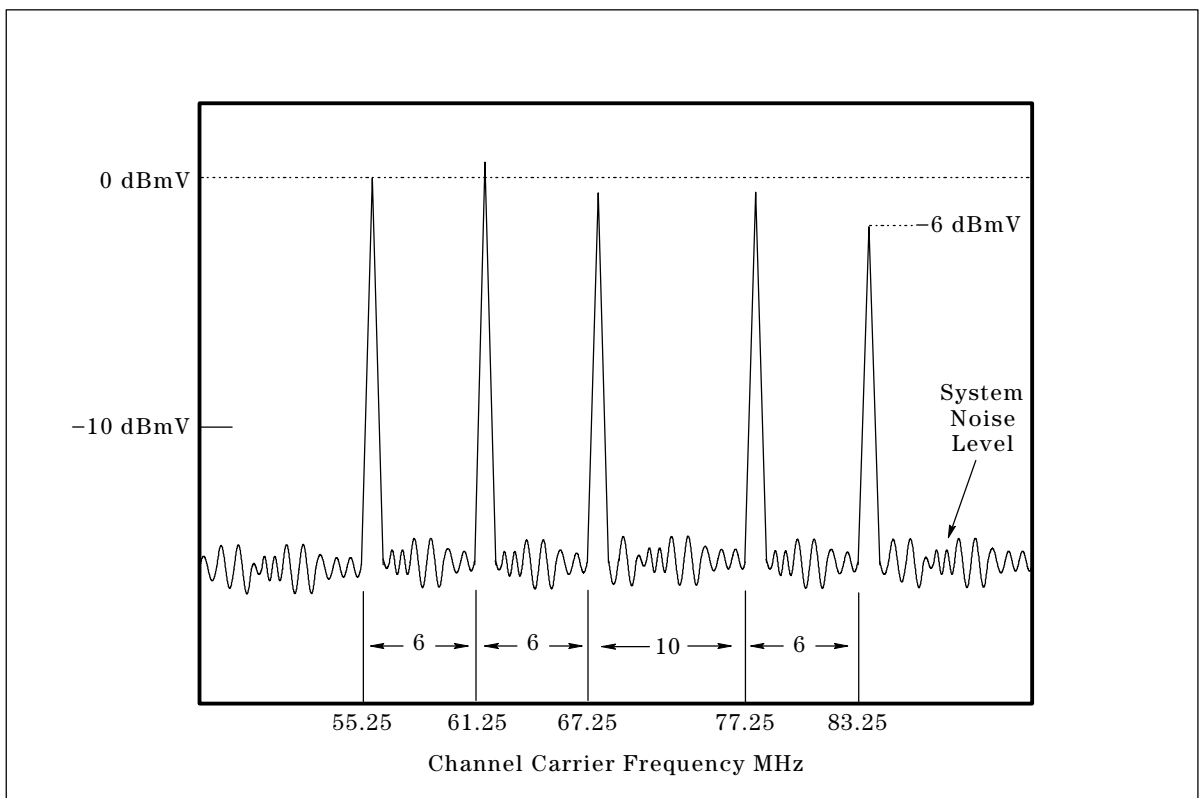
Now let's consider the various forms of signal level measurements in CATV systems. In Figure 1.3 typical dBmV levels are shown at various points throughout distribution lines. These levels represent the TV video carrier peak signal. The peak of the video carrier is simply the unmodulated carrier voltage, as shown in Figure 2.3. The peak detection value in Figure 2.3 (c) is the only meaningful signal level measurement because it is the maximum of the carrier signal as if it were unmodulated. Each visual carrier at the subscriber's drop must be at a specified power minimum level and within a given number of dB from each other. (Chapter 4 deals with these specifications in detail).

When viewing the TV channels in a spectral display, that is, a display of signal amplitude versus frequency, these specifications take on clearer meaning. Figure 2.4 shows a simplified CATV spectrum. Nominally the absolute signal level is 0 dBmV. However, the end points, channel 2 and channel 6 are 6 dB apart, which is a factor of 4 power differential. The

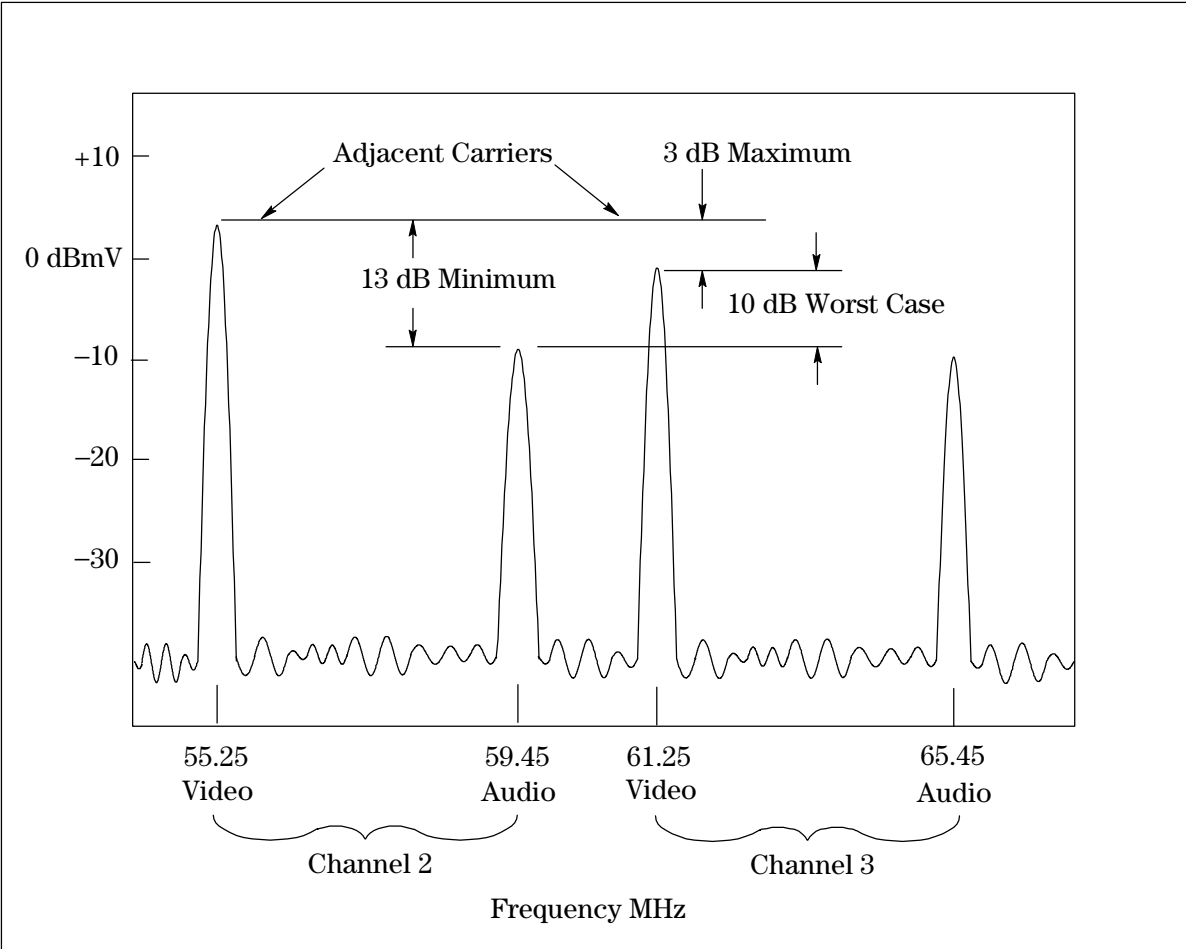
**PEAK DETECTION  
NECESSARY FOR  
CARRIER LEVEL  
MEASUREMENT**



**Figure 2.3.** Simplified TV carrier signal (a) unmodulated, (b) modulated, (c) detected (stripped of RF signal) for peak envelope response and (d) detected for average envelope response. The maximum RF signal level (peak) is the signal voltage proportional to the power of the signal since the impedance of the system is uniform  $75\Omega$ . A peak envelope detection scheme, (c), retains the peak power envelope information whereas the average envelope detection, (d), loses the information.



**Figure 2.4.** Diagram representation of spectral display of TV carriers for channels 2 through 6.



**Figure 2.5.** Adjacent carriers with their audio sidebands. Signal level specifications insure minima interference between the audio of one channel and the video of the adjacent channel.

home TV receiver displays the weaker signal, with "snow" and poor color quality, whereas the stronger channel 2 would be quite a bit less noisy.

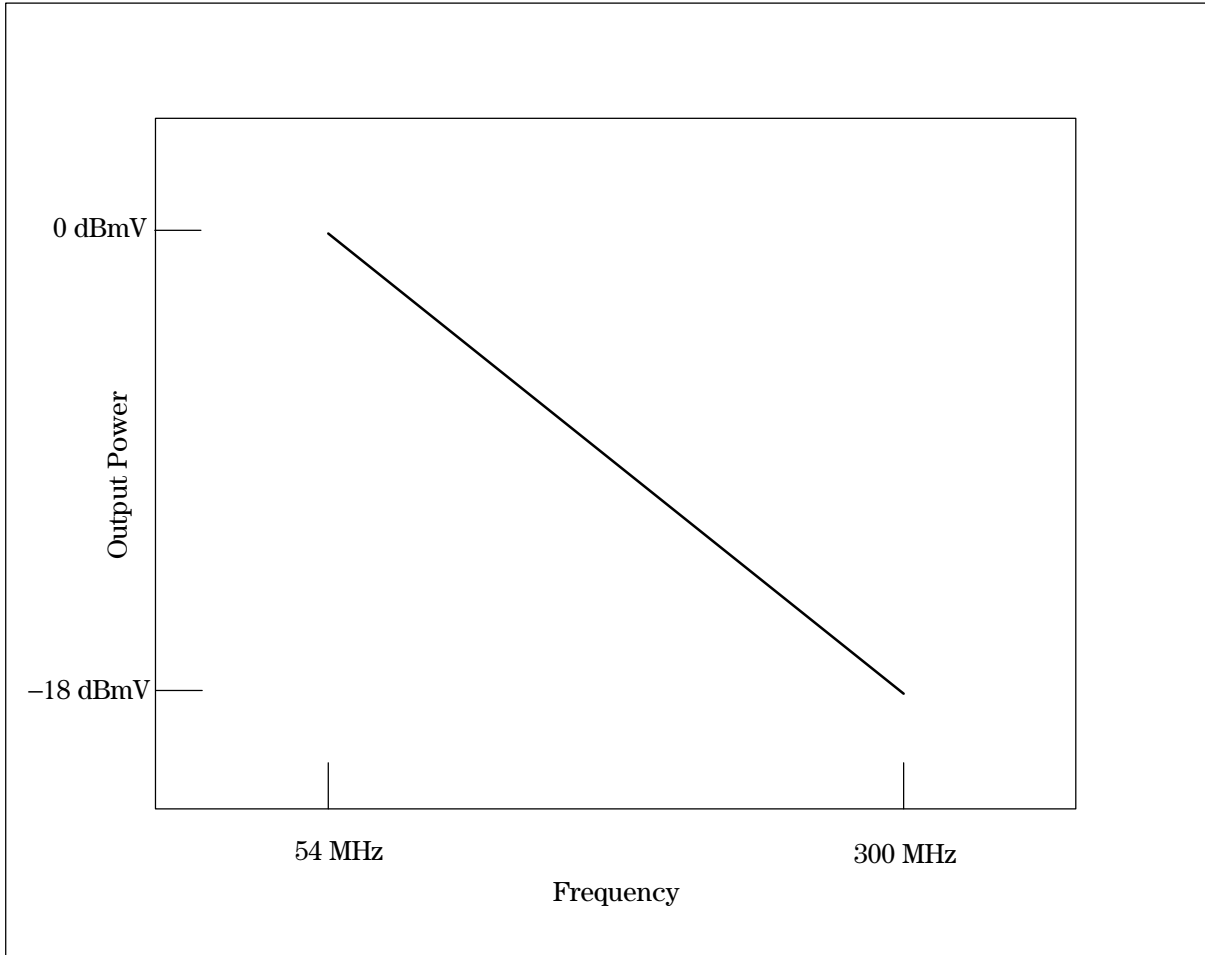
Power level versus frequency is called *flatness*. A *flat* system is one which will perfectly reproduce the power level versus frequency profile of a swept signal put in at the headend. Flatness needs to be specified along with *absolute signal level* to prevent wide variations in picture quality; too small a signal causing picture drop outs, or too strong a signal causing compression, adjacent channel and radiation problems. Complementing the flatness spec are the *audio* and *adjacent channel level* specs which insure that the various sideband components of the complex channel spectrum won't interfere with one another. Note that a system can be flat and still violate the adjacent channel specs.

In Figure 2.5 channels 2 and 3 are drawn along with their audio sidebands with the modulation off. The *adjacent signal level* must be within  $\pm 3$  dB and the aural carrier must be lower by 13 to 17 dB. This will insure that the channel 3 video will be at least 10 dB above the channel 2 audio, preventing audio modulation occurring on channel 3's picture. North American television standards are used as examples.<sup>1</sup>

<sup>1</sup>All examples use the United States FCC Rules and Regulations specifications.

**FLATNESS: HOW AMPLITUDE VARIES FREQUENCY**

**ADJACENT CHANNEL LEVEL SPEC PREVENTS CHANNEL-TO-CHANNEL INTERFERENCE**



**Figure 2.6.** CATV trunk cable frequency response for 1500 feet of cable between 54 MHz and 300 MHz.

Control of the CATV system's flatness is with automatic gain control (AGC) and automatic slope control (ASC) through the use of pilot tones inserted at two or more strategic frequencies. Cable losses are higher at higher frequencies so the flatness or *frequency response* of a cable looks like the illustration in Figure 2.6. For example, at 300 MHz a 1500 foot cable can lose as much as 18 dB more than transmission at 54 MHz. Cable manufacturers can provide the frequency roll off of their particular product. To compensate, the amplifiers along the way shape their gain response with *tilt* or *slope* adequate to boost the high frequency end of the signal. Pilot signal levels, and sometimes pilot sidebands, act as standards by which the system judges itself and adjusts AGC and ASC levels accordingly. Specifications for these pilots are set by the various equipment manufacturers and require checking as part of the routine maintenance of the system.

**CATV CABLE IS NOT FLAT:  
MORE LOSS OF SIGNAL AT  
HIGHER CHANNELS**

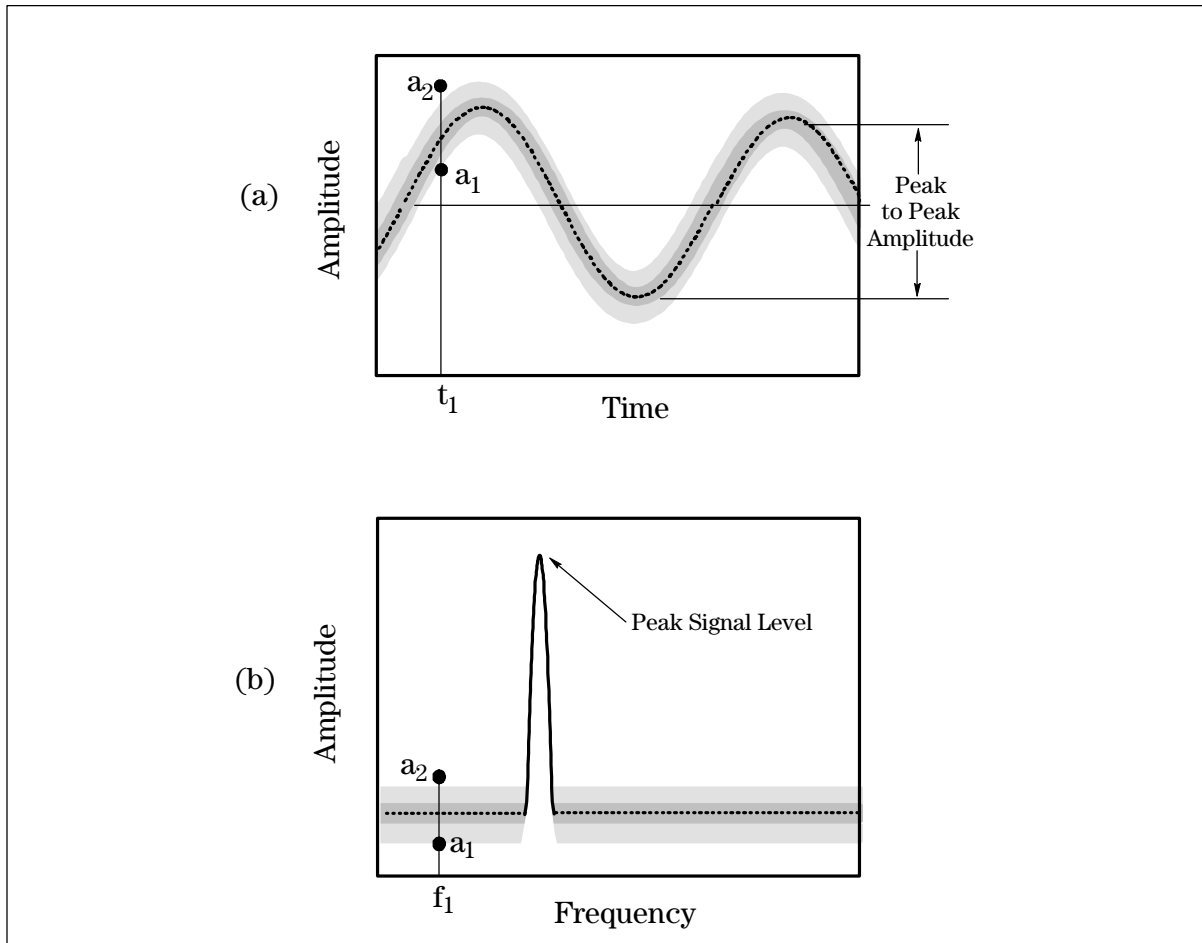
---

## Noise

The smooth orderly flow of the electrons of an RF signal can be disrupted by another type of signal energy whose electron flow is

---

**NOISE IS A SIGNAL**

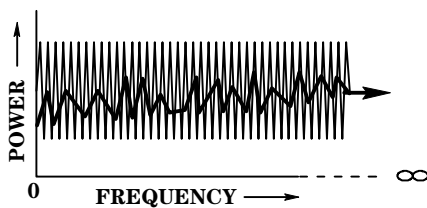


**Figure 2.7.** Signal and noise in the time and frequency domains. a) a sinusoidal signal in the time domain whose waveform is thickened by the random amplitude variations of noise. The dashed line represents the average of the noise signal, the sine wave itself. At time,  $t_1$ , the signal amplitude may be anywhere from  $a_1$  to  $a_2$ . b) In the frequency domain the same RF signal shows as a spike whose amplitude is representative of the signal level. The dashed line represents the average of the noise as in (a). At frequency  $f_1$  the signal amplitude again may be anywhere from  $a_1$  to  $a_2$ .

random. This randomness, caused by heat's action on resistive elements, is **noise**.

Noise has all the attributes of a signal; it has a level and frequency response and it can be amplified, transmitted and measured. Noise is detrimental to a CATV system because it distorts or obliterates desired signals. When amplified, noise increases disproportionate to the gain of the amplifier. The additional noise comes from the amplifier itself. (See amplifier **noise figure** later in this chapter.) In system design, noise figure is an expensive parameter to minimize. The alternative, maximizing signal level power, can be even more costly.

The randomness of noise gives it a theoretically infinite frequency spectrum. Figure 2.7 shows an RF signal imbedded in noise in both the time and frequency domains. At any one point in the time or frequency domains, noise appears as a range of amplitudes rather than a single value. The power of a noise signal can be measured if its amplitude is averaged over a specific frequency range. This parameter is called **noise power density**.



**NOISE SIGNAL LEVEL IS  
NOISE POWER DENSITY**

Noise measurements are referred to a standard frequency window, called a **bandwidth**, to keep the readings consistent. Since TV channels have most picture information within 4 or 5 MHz, CATV system noise is measured referenced to a 4 MHz bandwidth. The bandwidth of the signal analyzer making the measurement dictate the measurement bandwidth. Since this bandwidth is usually much less than 4 MHz, a correction must be made to the readings.

**NOISE POWER ALWAYS IS REFERRED TO A FREQUENCY BANDWIDTH**

Just remember that the wider the bandwidth used, the more noise power is detected by the measuring instrument and the higher the noise signal power. Very narrow bandwidths pass less of this random noise signal and are valuable in looking for small RF signals. For noise level measurements not made with a 4 MHz bandwidth a simple mathematical conversion is necessary. The noise power (in dBm or dBmV) changes as the ratio of the bandwidth:

**INCREASE BW MEANS INCREASE IN NOISE POWER**

$$\Delta NP = 10 \log_{10} \frac{BW_1}{BW_2}$$

- where  $\Delta NP$  = change in noise power in dB
- $BW_1$  = reference bandwidth, Hz
- $BW_2$  = test data measurement bandwidth, Hz

A simple rule of thumb for converting noise power with changing bandwidth: the noise power increases (decreases) 10 dB for every bandwidth widening (narrowing) by a factor of 10.

*Example: Noise in a trunk line terminal is measured at -25 dBmV with a 1 MHz bandwidth receiver. What is the noise power density in a 4 MHz bandwidth?*

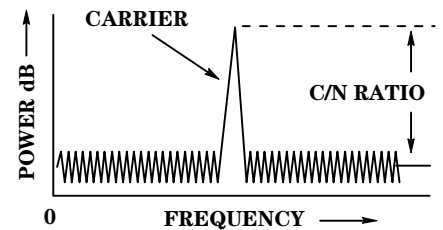
*From the formula above,  $BW_1 = 4 \text{ MHz}$  and  $BW_2 = 1 \text{ MHz}$*

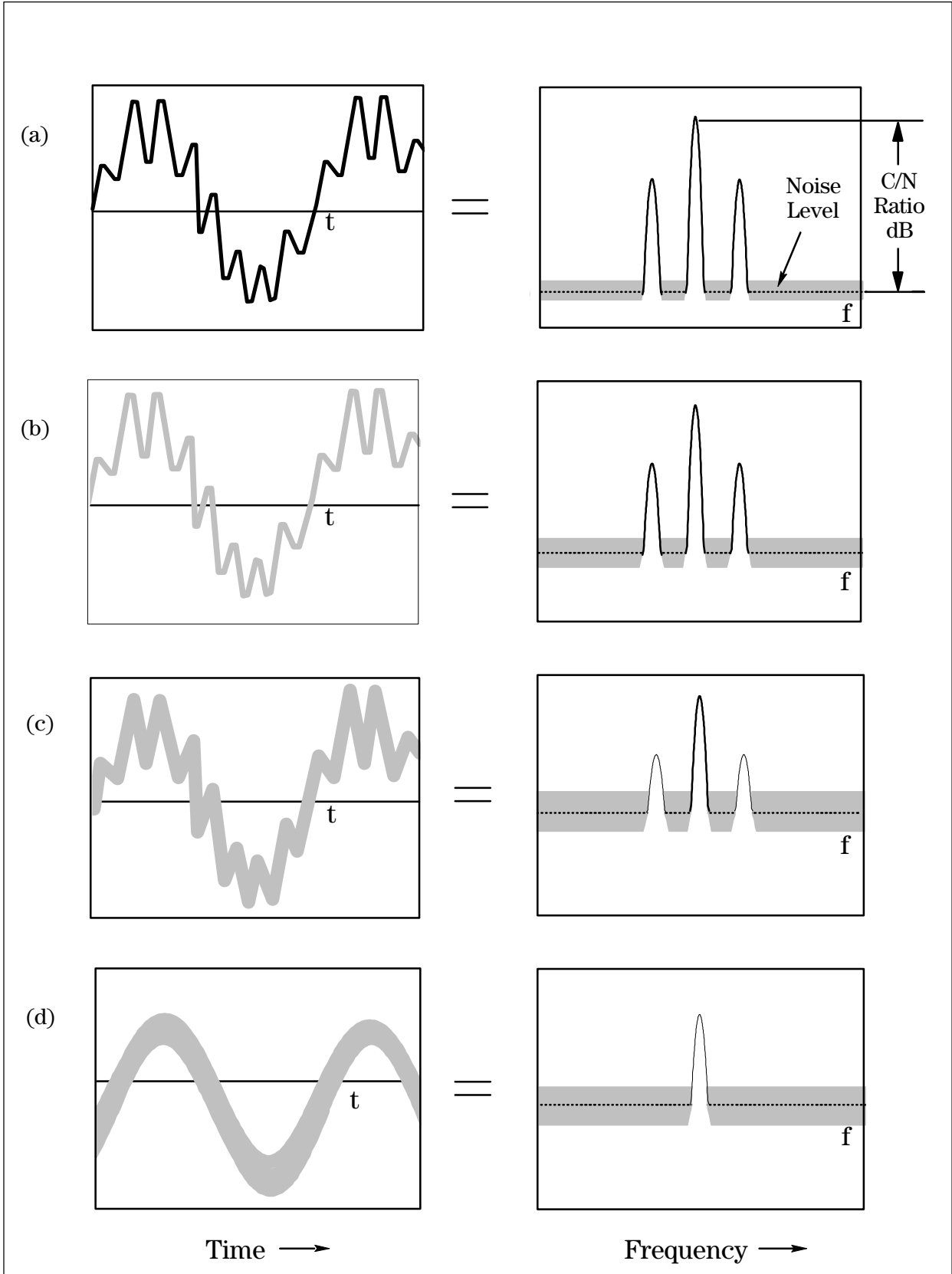
$$\Delta NP = 10 \log_{10} \frac{4 \text{ MHz}}{1 \text{ MHz}} = +6 \text{ dB}$$

$$NPD = \frac{-25 \text{ dBmV}}{1 \text{ MHz}} + 6 \text{ dB} = \frac{-19 \text{ dBmV}}{4 \text{ MHz}}$$

Noise is the culprit that can obscure or distort a signal. Figure 2.8 illustrates increasing noise in the time and frequency domains. In the figures from top to bottom, noise is increased until the AM information is completely masked by noise. A signal must be far enough out of the noise to prevent the noise from masking its modulation. This leads to another important CATV system parameter, its signal-to-noise ratio.

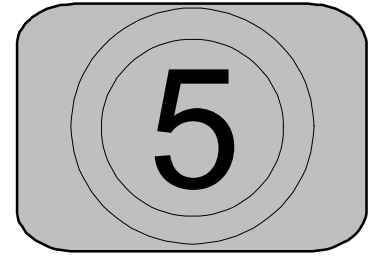
In CATV, this is called **carrier-to-noise** ratio since it is the ratio of the video carrier level to the system noise level. This carrier-to-noise ratio, abbreviated C/N, is in units of dB, a power ratio. Figure 2.8(a) graphically shows an example of this type of measurement in the frequency domain.





**Figure 2.8.** Modulation being obscured by increasing noise shown in the time and frequency domains. The noise increases in the sequence a), b), c). In d) the noise level increase completely obscures the sidebands.

When the C/N ratio approaches 40 dB at the subscriber's terminal, picture quality begins to degrade. A noisy picture appears to have a random fuzziness, sometimes called "snow," that obliterates resolution and contrast. Just as in the simple AM example in Figure 2.8, as the noise level increases, the various sidebands of the video carrier are lost to the receiver.



**LOW C/N RATIO**

Why is noise a problem in a CATV distribution system? As the signals are amplified through the trunk and feeders, noise increases faster than the carrier levels, thus degrading the C/N. Noise power is amplified in an amplifier dB for dB with CW signals. But the amplifier adds a measure of its own noise to the output because of the inherent noise of active devices such as transistors. The noise contribution made by an amplifier is called its *noise figure*.

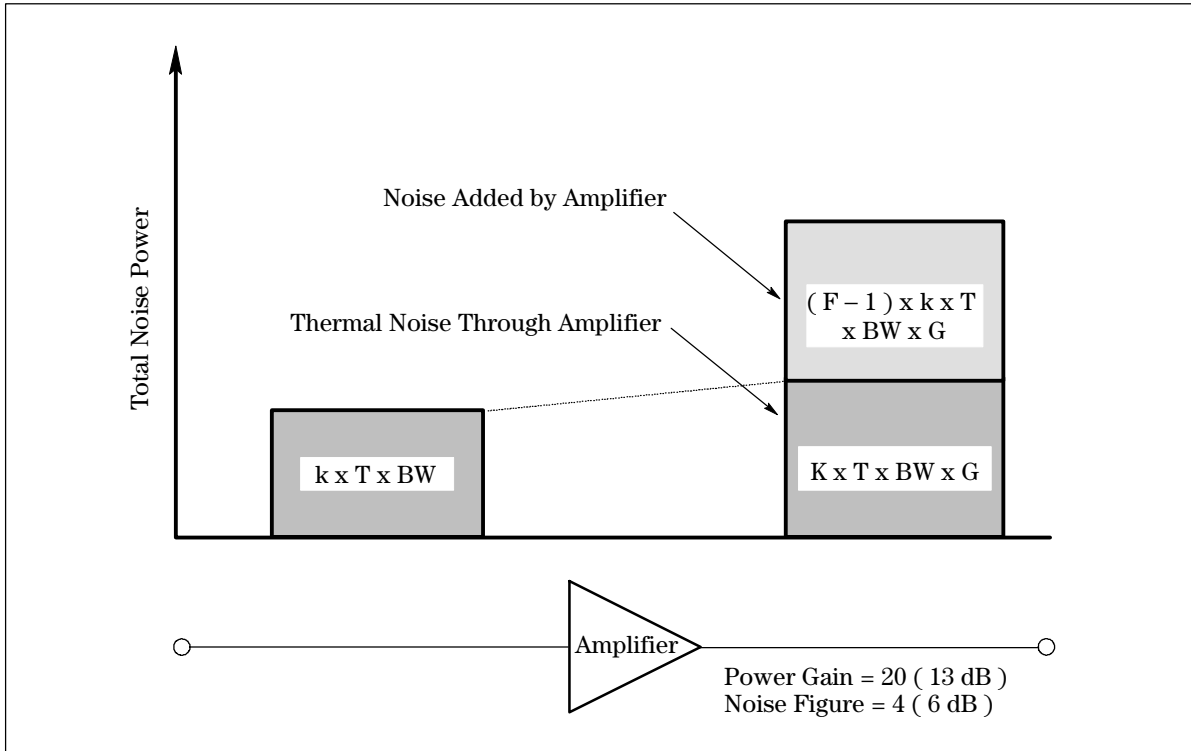
Figures 2.9 and 2.10 graphically show the addition of noise in a single amplifier and the effect of cascading two amplifiers.

**NOISE FIGURE TELLS HOW MUCH EXTRA NOISE AN AMPLIFIER ADDS**

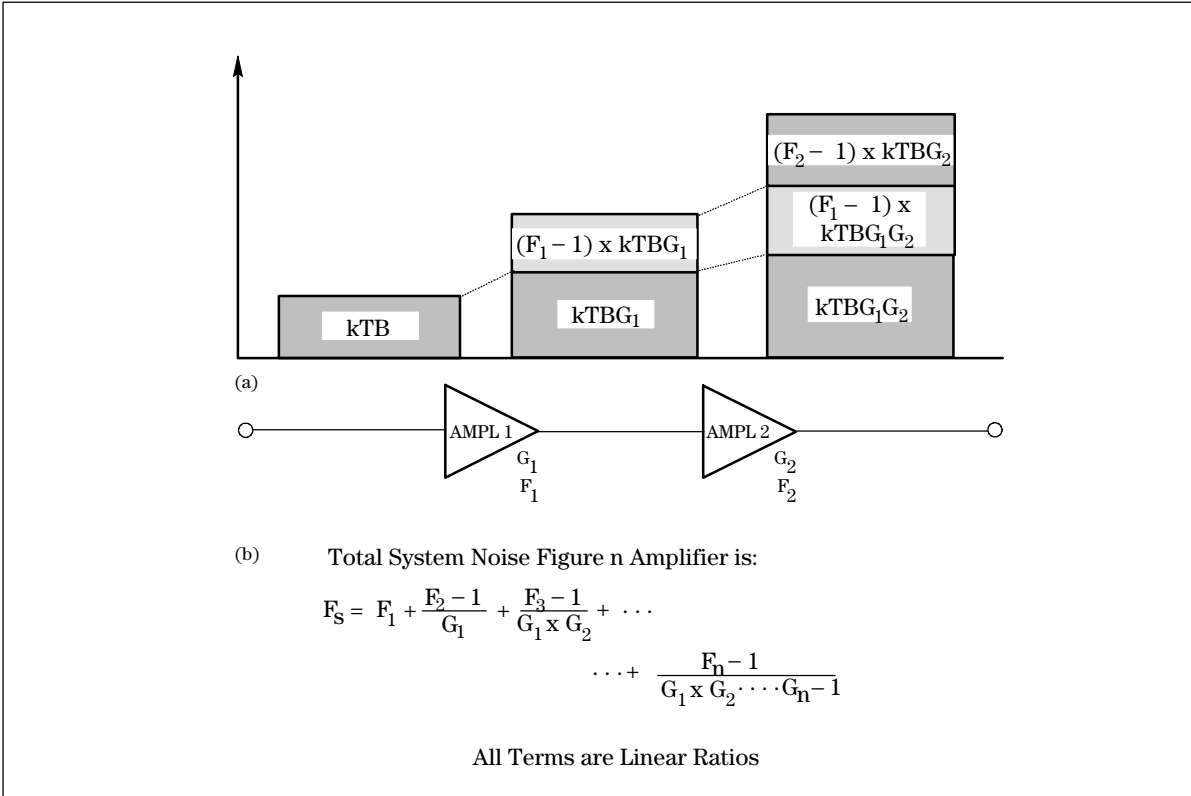
NAME	DESCRIPTION	DEFINITION
Noise Power Density, N	Noise Power Level over a specific band of frequency in watts	$N$ (Watts referred to Hz) = $k T B$ $k$ = Boltzman's constant $1.374 \times 10^{-23}$ Joule/ $^{\circ}$ K $T$ = Temperature in $^{\circ}$ Kelvin (Room Temp = $290^{\circ}$ K) $B$ = Frequency Bandwidth, Hertz  $N$ (dBw) = $10\log_{10} kTB$  $N$ (dBm) = $10\log(kTB) + 30$  $N$ (dBmV) = $10\log(kTB) + 78.75$
Carrier to Noise Ratio, C/N	Power Difference between carrier signal and noise power density, in dB	$"C/N" = C - N$  $C$ = Carrier Level Power, dBmV $N$ = Noise Power Density, dBmV/unit bandwidth
Noise Figure, Noise Factor, F	Input S/N to Output S/N of Amplifier (where S/N = signal-to-noise ratio)	$F = S/N$ Input - $S/N$ Output = Noise Factor $F(\text{dB}) = 10\log_{10} S/20/1$ Input - $S/10/1$ Output = Noise Figure  where S/N power ratios, not dB  $10\log_2 = 3 \text{ dB}$

**Table 2.2.** Noise terminology





**Figure 2.9.** The effect on noise power by an amplifier. The input noise is amplified directly by the amplifier gain. An incremental amount of noise is added, depending upon the noise figure and gain of the amplifier.



**Figure 2.10.** System noise figure for cascaded amplifiers. As in Figure 2.9 (a) shows the manner in which kTB input thermal noise is compounded by the gain of the amplifiers as well as their noise figures. The general equation (b) relates the gain and noise figures of each amplifier to the total system noise figure.

---

## Interference

Any signal present within the passband of the TV channel which causes a degradation of the receiver's quality is called an interference signal. This interference signal's source may be originated outside the system (co-channel and ingress) or generated within the system (coherent disturbances such as inter-mod, hum and cross modulation). The system may cause interference outside (radiation). The remainder of this chapter examines these internal disturbances, relating them to signal to reception quality.

---

**INTERFERENCE =  
CO-CHANNEL, INTERMOD,  
HUM, CROSS MOD OR  
RADIATION**

---

---

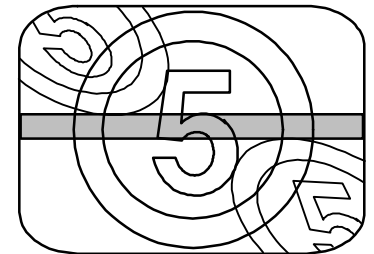
## Ingress and Co-Channel Interference Interference From Outside the System

There are a number of entrances for unwanted signals in a CATV system. They can enter through the antenna at the head end or be picked up by RF leaky field distribution equipment. One common interference signal comes from a strong local station radiating onto the CATV cable system. If the station is carried on the system in the same channel slot then the TV receiver will show a leading ghost picture, due to the system distribution delay. The ghost would appear as background to any channel put on the system at the broadcast frequency. The term *direct pickup* is used to describe the type of interference.

---

**CO-CHANNEL IS THE  
PICK-UP OF TWO  
STATIONS IN ONE  
CHANNEL SLOT**

When two broadcasting stations using the same channel are within pickup distance of each other their carriers are offset by  $\pm 10$  kHz to prevent TV receiver interference. The CATV antenna picks up these "co-channels" along with the desired signals and distributes them unimpeded (since they are well within the channel passband filters) resulting in *co-channel interference*. If the co-channel level is high enough the TV receiver will display two channels on one channel.



**CO-CHANNEL INTERFERENCE**

Figure 2.11 illustrates the appearance of co-channel interference in the frequency domain. At interference levels greater than  $-50$  dBc picture distortion is evident. As shown, the audio of the channel is also distorted by the co-channel audio signal.

Ingress occurs when other signals are received in the passband of the cable system headend feeds. The interference cause depends on the type of signal and is impossible to prepare for. Identification of these signals by monitoring and listening will help find the culprit.

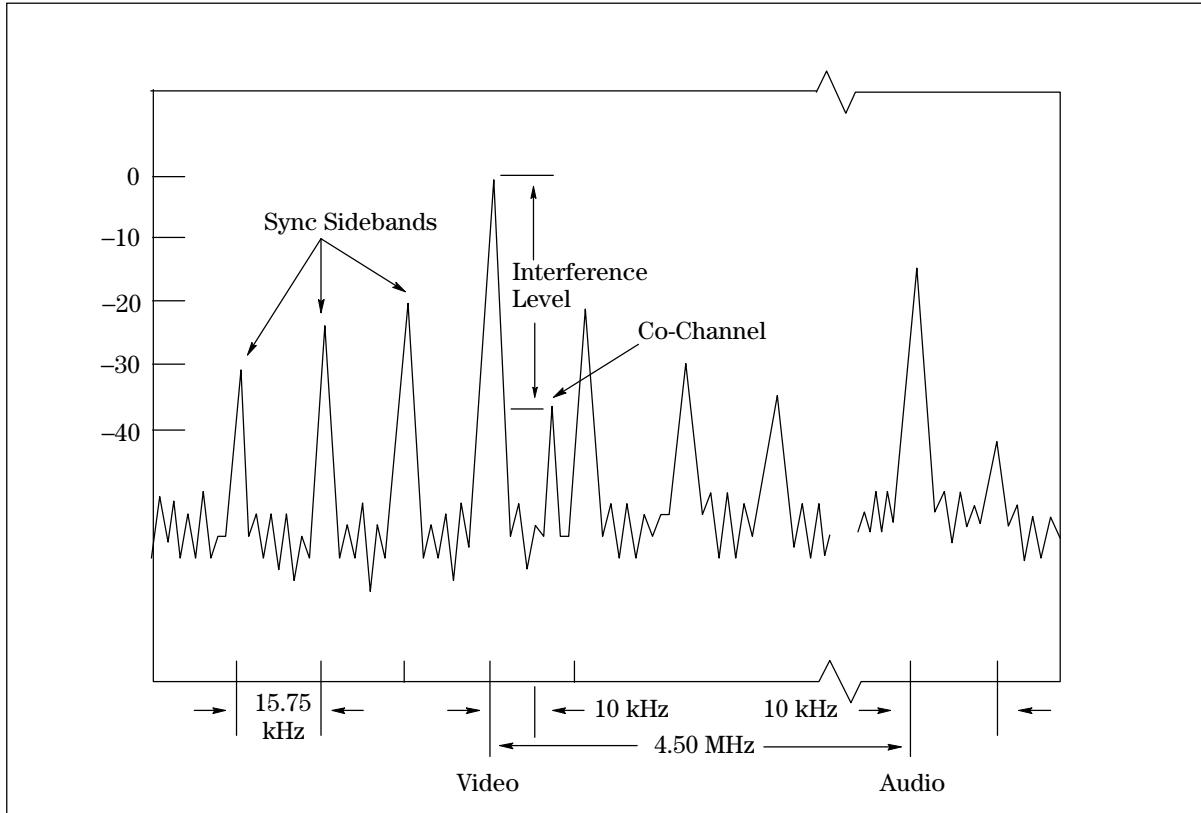
---

## Low Frequency And Coherent Disturbances Interference From Within The System

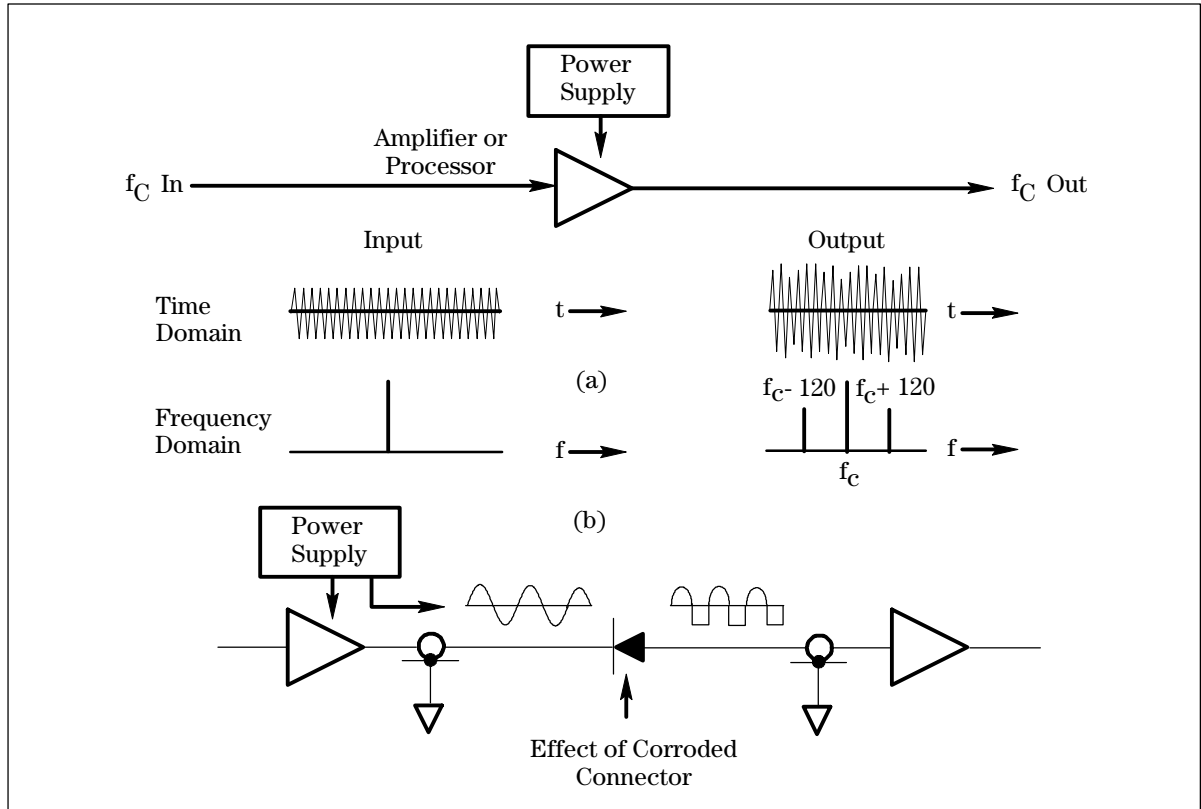
More serious in nature are the interference signals which fall in the TV spectral bandwidth that are generated within the CATV system itself. Let's start with the simplest of these, *low frequency disturbance*, or

---

**HUM COMES FROM  
POORLY REGULATED  
POWER SUPPLIES**

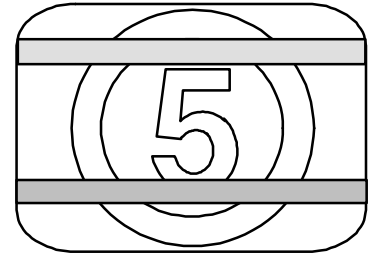


**Figure 2.11.** Co-channel interference on the video and audio of a single channel in the frequency domain. The specification is measured from the video carrier peak to the top of the interfering carrier.



**Figure 2.12.** Hum sideband generation.

**hum.** Hum is an amplitude modulation of the carrier by a signal whose frequency is usually a harmonic of the power line frequency. It can be generated from any number of the active devices or passive connectors along the distribution line. Figure 2.12 explains the fundamentals of how these are generated. Hum may be the result of a poorly regulated power supply amplitude modulating the RF signal. In Figure 2.12. a) An active device such as a distribution amplifier or processor modulates the RF wave. Usually the rectification problem is symmetrical, that is, the DC voltage is bumped twice for each AC line voltage cycle. This causes hum sidebands that are two times the line frequency. b) When AC power is fed down the cable to power several amplifiers a corroded connector can act like a crystal diode, partially half-wave rectifying the 30 or 60 volt AC wave. This asymmetrical AC voltage is rectified by downstream distribution amplifiers resulting in a hum noise whose frequency is exactly that of the line frequency.



**HUM INTERFERENCE**

In the frequency domain hum sidebands appear as two signals symmetrically placed on either side of the carrier and spaced the line frequency or its harmonic away, as Figure 2.12 shows. One or two horizontal bands appear when the interference levels exceed -32 dB down, that is hum sidebands are less than 32 dB from the carrier peak. For a 60 Hz monochrome TV transmission, these lines will be stationary, and for the 59.94 Hz rate of color transmission the 60 Hz hum lines will slowly move through the picture in the opposite direction of the field scan.

**HUM INTERFERENCE IS AMPLITUDE MODULATION**

Disturbances that are distortion products resulting from combinations of the signals in the system are called **coherent disturbances**. **Intermodulation** products are generated by active devices in the system operating in their non-linear mode. Figure 2.13 gives more detail.

**INTERMOD: EXTRA SIGNAL IN CHANNEL PASSBAND CAUSED BY THE SUM AND THE DIFFERENCE OF OTHER SIGNALS**

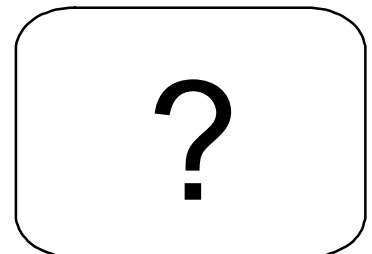
An intermod product's frequency is given by

$$n_1f_1 \pm n_2f_2 \pm n_3f_3 \pm \dots$$

where  $f$  = the frequency of any system signal

$n$  = an integer harmonic number

Intermod products are given an order number for the sum of the  $n$ 's in the frequency formula. For example:  $1f_1 + 2f_2$  is a  $(1 + 2)$  or 3rd order intermod product;  $2f_6 - 3f_1$  is a  $(2 + 3)$  or 5th order intermod product;  $f_1 + f_2 - f_4$  is a  $(1 + 1 + 1)$  or 3rd order intermod.

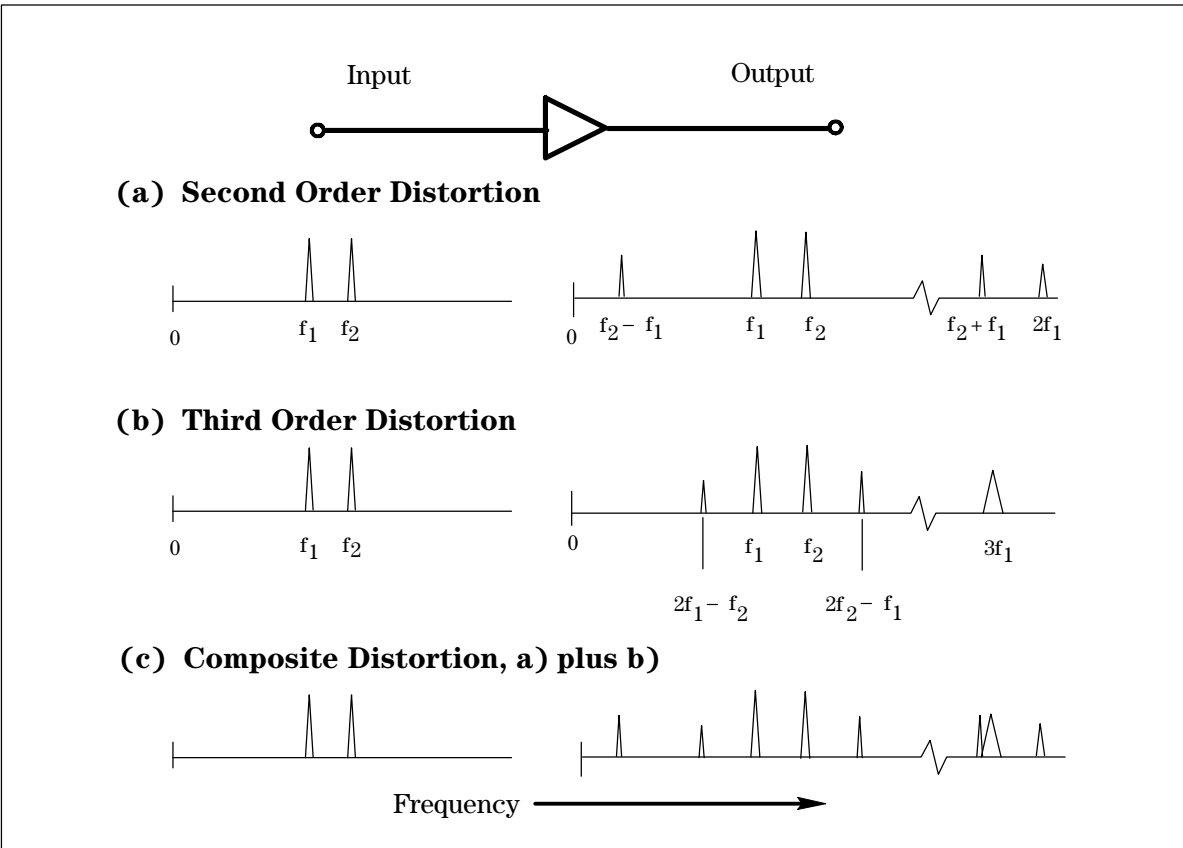


**INTERMOD CAN AFFECT THE RECEIVER MANY DIFFERENT WAYS**

Second and third order products are the strongest distortion signals; the higher order distortions tend to be much lower in magnitude. In addition, the lower order products also tend to fall into the system's channel bands more frequently. These products are so important they are given specific names. Third order intermod is **composite triple beat** or **CTB**. Second order intermod products are called **composite second order**, or **CSO**. **Composite** is the effect of distortion from different system signals falling on the same frequency.

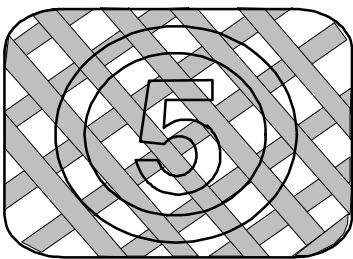
**TRIPLE BEAT IS THE STRONGEST INTERMOD**

The strongest CTB is an  $f_1 \pm f_2 \pm f_3$  product since each signal is a fundamental ( $n = 1$ ) whose mixing power is high. Table A.3 in Appendix



**Figure 2.13.** The source of coherent disturbances such as second order and third order intermodulation. a) Second order products, such as harmonics. b) Third order intermodulation products produce signals within the channel spacing. c) The distortion products of a) and b) combine and overlay one another, forming composite signals.

A, page A-3, provides a listing of triple beat intermod products. The next most troublesome intermods are the 3rd order  $f_1 \pm 2f_2$  products. In most systems these composite products fall  $\pm 0.75$  MHz and  $\pm 1.25$  MHz away from the carrier.



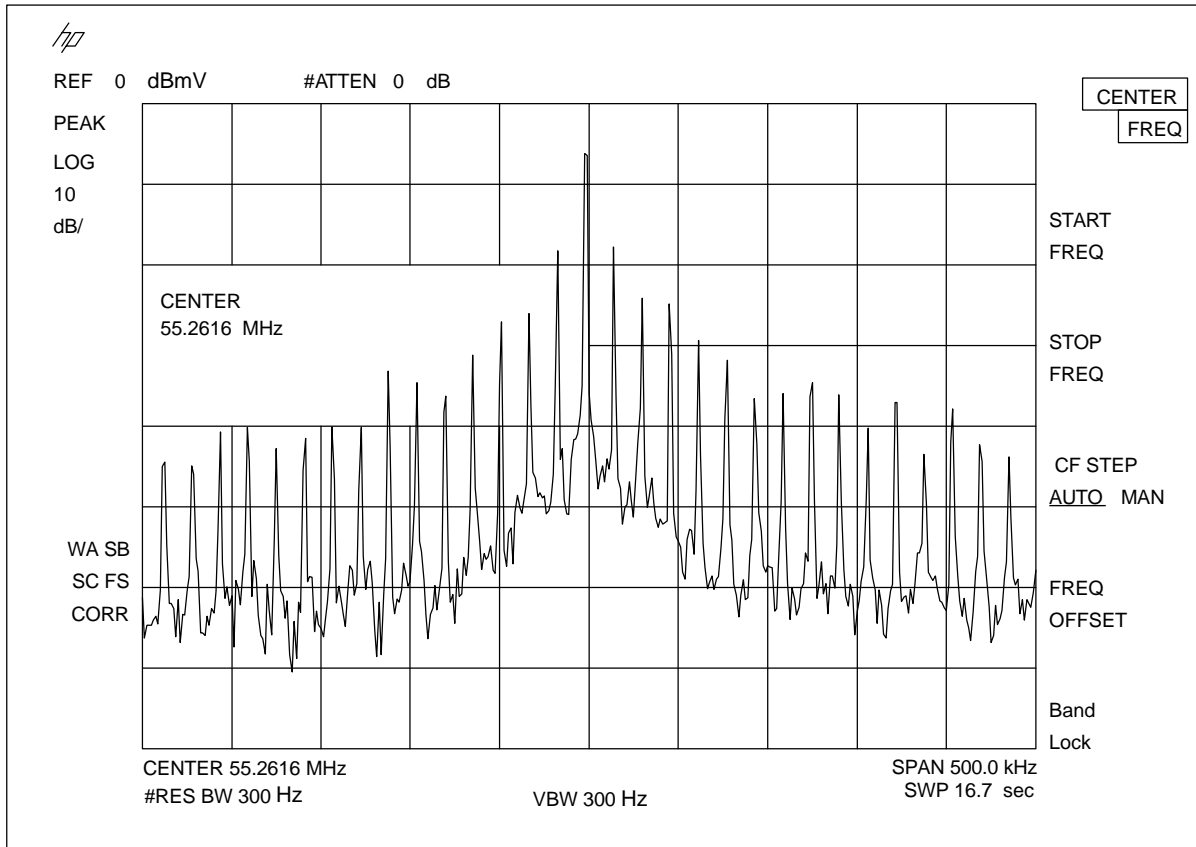
**CROSSMODULATION**

Because of the tendency of systems to have uniform channel spacing, second order products fall, by design or fortune, on the visual carrier frequencies. The composites of these must be quite strong to cause distortion of the picture.

In addition to CSB/CTB, CATV systems are also subject to distortions caused by the crosstalk of one channel on another called **crossmodulation**, or **crossmod**. It is particularly troublesome in TV spectra because of the type and amount of modulation that is carried by the TV signal.

**CROSS MODULATION IS  
AKIN TO CROSSTALK  
ONE CHANNEL  
MODULATING ANOTHER**

Crossmodulation, like its crosstalk cousin, simply means a desired channel is being modulated by another; that is, some of the modulation sidebands on the desired channel are due to another channel. In telephone crosstalk this effect is a second conversation on the phone while you're trying to talk. In TV the effect is jittery diagonal stripes on the picture, generated by the 15.75 kHz sync pulses of other channels being impressed upon the received channel.



**Figure 2.14.** Spectrum analyzer display of carrier and 15.75 kHz sidebands shows the complexity of video modulation.

## Measuring Distortion

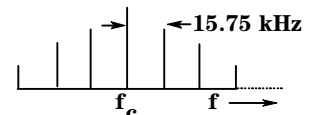
How is distortion measured? A look at how crossmod appears in the frequency domain shows how distortion is measured. Figure 2.14 shows a high resolution frequency domain display of the TV video carrier. The most dramatic characteristics are the evenly spaced sidebands.

This spacing is the signal's modulation rate of 15.75 kHz caused by the amplitude modulation of the carrier by the horizontal sync bursts.

Figure 2.15 shows the differences between television amplitude modulation, and the textbook AM as defined by the IEEE. These differences are important to the way a signal analyzer measures. In the IEEE-defined AM, as modulation index is increased the carrier remains constant and the sidebands increase, thus the total signal power increases. This is not the case with the NTSC and PAL TV carrier modulation; since modulation is only down from the carrier peak, 0% modulation is at the peak, and 100% is at 0 Volts. White level is set at 87.5%.

So, getting back to the point, how is distortion measured? Simply turn off the modulation to a channel and use a signal analyzer to measure the remaining 15.75 kHz sidebands. This sideband is modulation from all the other system channels operating in their normal fashion. Comparing the

### CARRIER SPECTRUM:



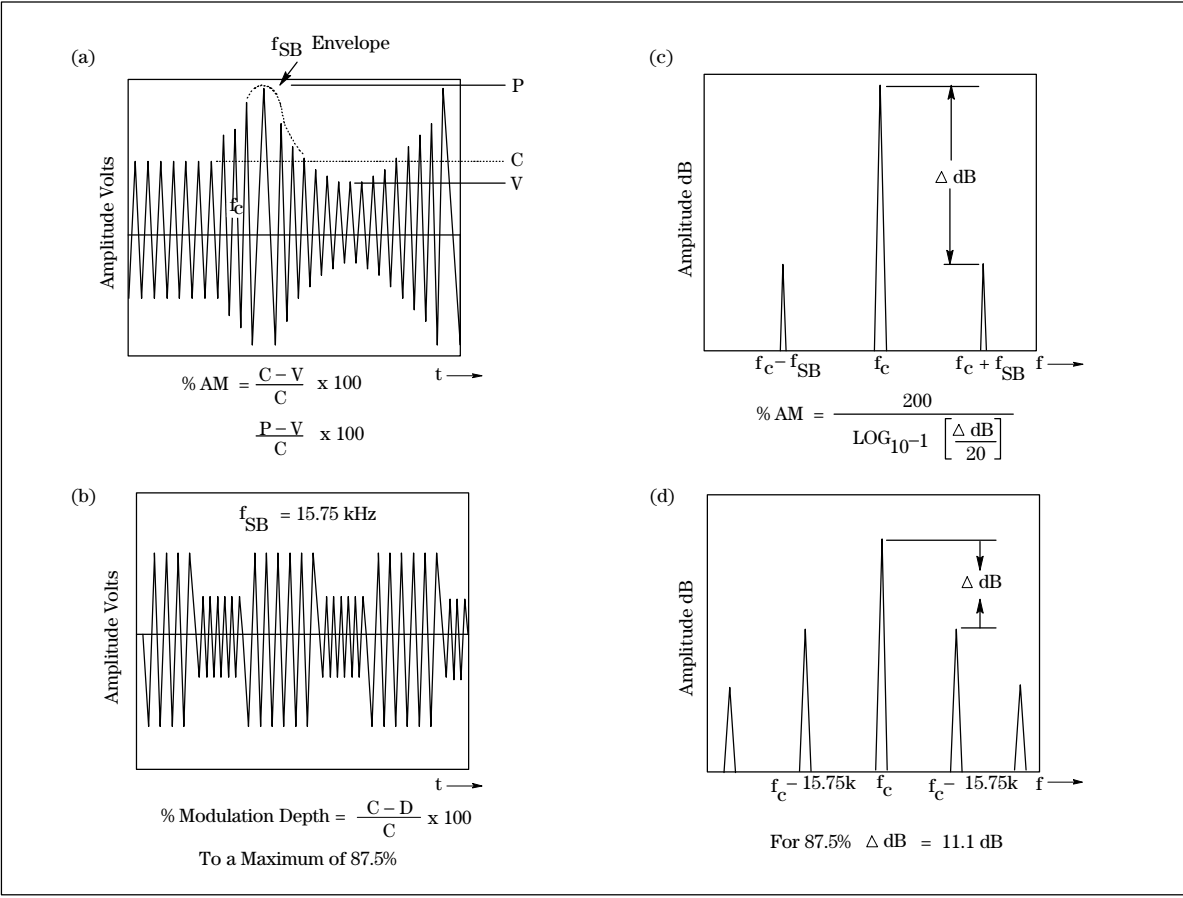
### MODULATED CARRIER



### UNMODULATED CARRIER



### UNMODULATED CARRIER WITH CROSMOD



**Figure 2.15.** Typical AM modulation and its relation to TV carrier modulation. a) and b) The time domain displays of a conventional IEEE defined AM and a simplified TV carrier showing how their levels of modulation are defined. c) and d) The frequency domain displays of each modulation with a signal analyzer's interpretation of the modulation level. With the TV carrier AM percent cannot be expressed as equation because the pulse characteristics of the TV carrier add sideband energy which does not conform to either the AM nor the pulsed RF spectral response rules.

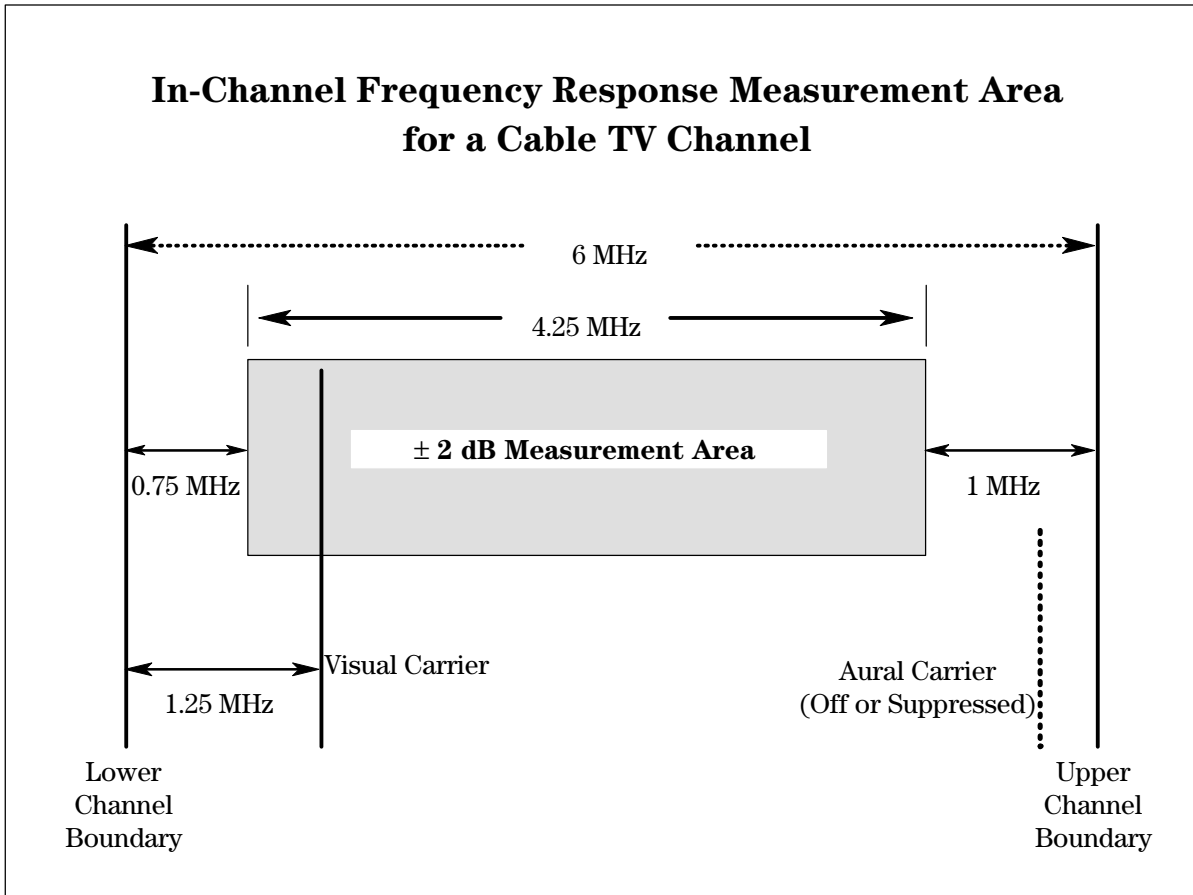
sideband power with the carrier power gives a number that can be used to quantify distortion. Picture interference begins to occur at -48 dB crossmod level. It shows up as stripes across the screen, sometimes fast as a waterfall effect, or, slow as a windshield wiper effect.

When the regular programming is restored to our test channel, the crossmodulation sidebands will not be visible in the frequency domain; they will be buried under the regular modulation. In other words, to measure crossmod, channel modulation needs to be turned off.

## Channel Frequency Response

### FREQUENCY RESPONSE IS A NETWORK MEASUREMENT ON PROCESSOR (MODULATOR)

Uniform response over the channel bandwidth assures proper relative signal levels throughout the system and balanced response at the subscriber's terminal. To simplify trouble shooting, the headend and distribution system should be tested separately.



**Figure 2.16.** In-channel frequency response is a window of amplitude between the vestigial sideband and the aural carrier. For a specification of  $\pm 2.0$  dB, the total swing allowed between minimum and maximum is 4 dB.

The response of any one channel is influenced by the channel processor at the headend. Aligning the processor's frequency response is usually done only by the processor's supplier. Once installed in the headend, a processor's output flatness needs to be monitored, and when found faulty, the modulator repaired or replaced.

Figure 2.16 shows how channel frequency response is specified. The flatness can be measured in two ways. First, a simple network analyzer test. Providing a sweep oscillator signal at the video input which covers the processor's frequency range at its specified power level. A signal analyzer at the processor's RF output measures the flatness.

The second test method does not require taking the processor off-line. A video test signal is added to the RF channel's signal on one of its horizontal test lines. This technique is less accurate, but fast and non-interfering.

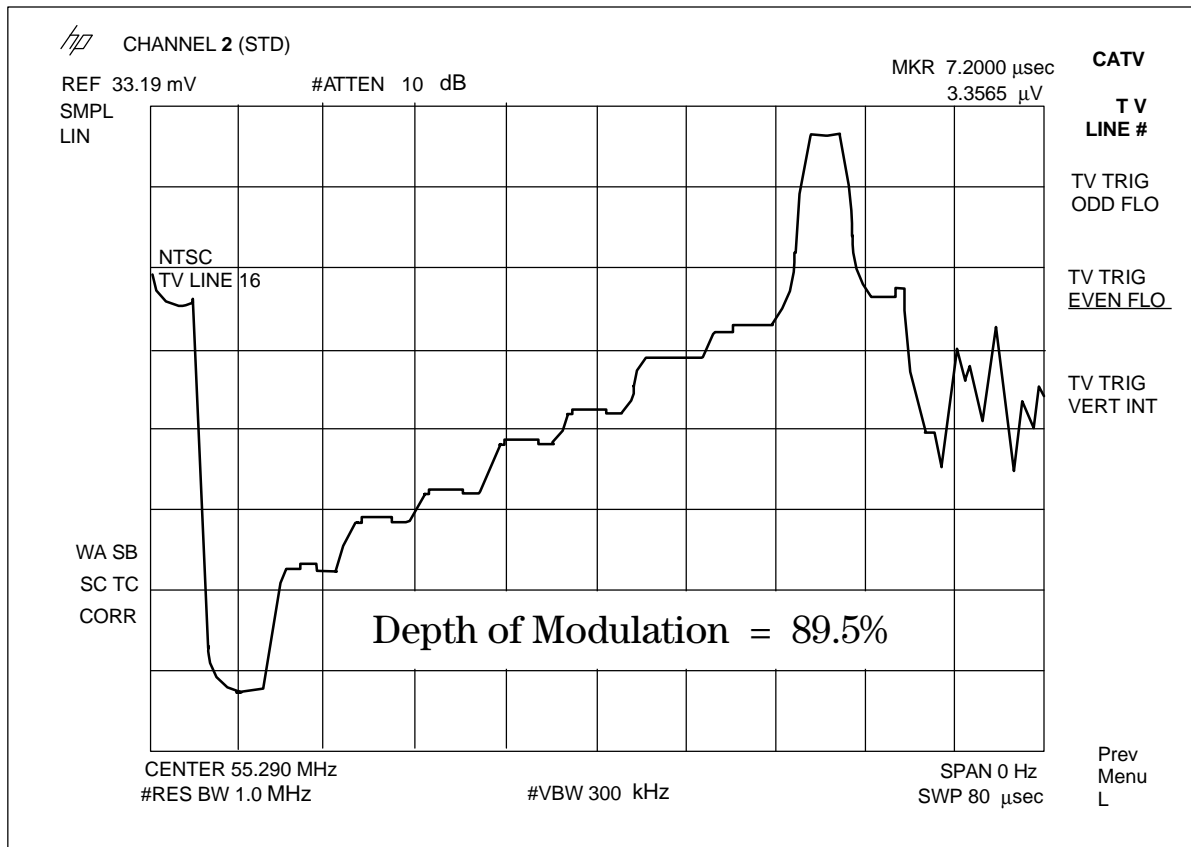
- OFF-LINE  
MEASUREMENTS**
- RF SWEEP
  - VIDEO TEST SIGNAL

---

## Depth of Modulation

Video is transmitted by amplitude modulating an RF carrier. After modulation, the lower sideband is reduced to conserve spectrum,





**Figure 2.17.** Depth of modulation is a measurement of the program video voltage relative to the horizontal sync pulse level.

vestigial sideband filtering. PAL and NTSC video formats require that the horizontal synchronization pulses correspond to maximum carrier level. The depth of modulation is measured as the percentage of the total amplitude change of the carrier, as the signal progresses from synch tip to peak white. Standard video modulation requires 87% of the total range of the carrier envelope, from full carrier to no carrier. That is, during sync tips, the carrier is at maximum amplitude. When a white portion of the picture is encountered, the carrier amplitude is reduced to 11.5%, that is the difference of maximum modulation, 87.5%, from 100%.

Subscriber symptoms for low modulation are reduced color and contrast. Over modulation, that is exceeding the 87.5% modulation, causes the video carrier to disappear during peak white video. When the carrier goes very low in voltage subscribers lose the sound signal because the aural carrier disappears; the sound is a modulation sideband of the visual carrier. When the sound disappears the 60 Hz vertical sync is heard as a loud buzzing as the vertical pulse modulates the receiver's automatic gain control and turns up the gain on the only audio signal available.

A test signal transmitted on the vertical interval test line of program video provides a standard to calibrate the video depth of modulation. Program video may occasionally show over modulation on a poorly set modulator, but cannot be used to bring the unit in specification.

## DEPTH OF MODULATION AS A RELATIVE MEASUREMENT

---

## System Frequency Response

Carrier levels and system flatness must be checked throughout the CATV system to prevent variations in picture quality. In the extreme case, gaps in system response, called suckouts, caused by a cable or amplifier faults, can make entire groups of channels disappear. The system frequency response measurement is often called system sweep, and is used to maintain system flatness.

The earliest and most dependable method for measuring system frequency response is to inject a strong CW signal at the headend which is swept over the entire system frequency range. A signal analyzer at each required test point collects spectral response data. Flatness and suckouts can be documented quickly and easily. This technique has one drawback: subscriber service and system communications is interrupted on each sweep. In addition to regular program material being interrupted, scrambled channels, pay-TV programming instructions, two-way subscriber services will be disturbed on each sweep of the headend generator.

Dedicated system sweep equipment, which uses coordinated burst signal technique, can minimize the effects on subscriber services.

The other method for measuring system flatness does not interrupt subscriber services, that is, it is non-interfering. The measurement does not require a sweep generator nor any other test equipment. The type of program material does not affect the measurement accuracy; scrambled as well as non-scrambled channels can be compared. The only disadvantage is that system flatness over frequency ranges void of signals are not measured. Today, however, fewer systems have these open spaces.

A spectrum analyzer is the ideal signal analyzer for either method of measuring frequency response. It collects and displays frequency response data over the entire frequency ranges quickly for evaluation.

---

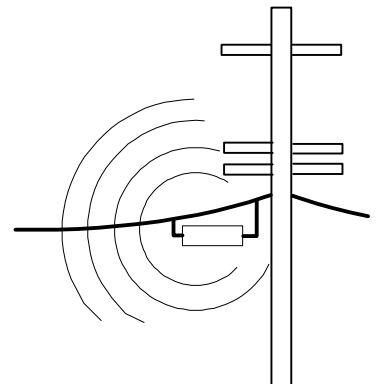
**SYSTEM SWEEP  
CAN INTERRUPT  
SUBSCRIBER SERVICE**

**SPECTRUM ANALYZER  
PROVIDES NON-  
INTERFERING TEST**

---

## Interference Outside the System

Ideally all the distributed CATV signals are contained within the cable network. But signal leakage from systems can radiate to interfere with local VHF/UHF communication. Evidence has even been found to show that VOR and ILS air navigation receivers could be misled by the radiated CATV intermod beat frequencies which escape a leaky distribution system. Corroded connectors and other distribution hardware breakdowns are generally responsible for leakage, but high subscriber signal levels can also be at fault. High levels at a customer drop can cause radiation through the subscriber's old TV antenna if it's still connected to the receiver. But the major causes of distribution systems **radiation** are leakage and poor ground, both the results of hardware failure. Signal radiation by leakage means the CATV signals are radiating



**RADIATION:  
INTERFERENCE FROM  
CATV DISTRIBUTION  
HARDWARE**

from an opening in the shielding of the distribution system. The opening is acting like an antenna. Poor grounding make even leak-proof shielding ineffective, An ungrounded outer conductor simply reradiates the center conductor's signal to the outside.

**CAUSES OF RADIATION:  
1. POOR GROUND  
2. LEAKAGE**

Let's look at the characteristics of the radiated signals. Radiation of a signal, just as in our previous discussion of signal level, presupposed the transfer of energy and therefore the flow of current. Current induces a magnetic field which can be used to quantify the amount of energy in a radiated signal. Space has an associated impedance of  $377\Omega$  which converts our current flow into a voltage differential, E, over a section of space. The relationship is

**OHMS LAW:  
V = I x R**

$$E = H \times Z$$

where E = electrical field strength,  
RMS volts per meter

H = magnetic field strength,  
webers per square meter or Tesla

**FIELD STRENGTH:**

$$E = H \times Z$$

WHERE Z =  $377\Omega$

So, by knowing either E or H you know the other. This defines **field strength**.

**ANTENNA CORRECTION  
FACTOR K, TELLS HOW  
MANY VOTS AN ANTENNA  
WILL OUTPUT WHEN  
PLACED IN A PARTICULAR  
ELECTRIC FIELD**

An antenna translates the spacial field strength into some easily measured quantity, namely volts. At any one frequency the field strength blanketing the antenna will produce a specific voltage at the antenna terminals. The relationship between this voltage and the field strength is the **antenna correction factor**, K. From Figure 2.18.

$$E = KV$$

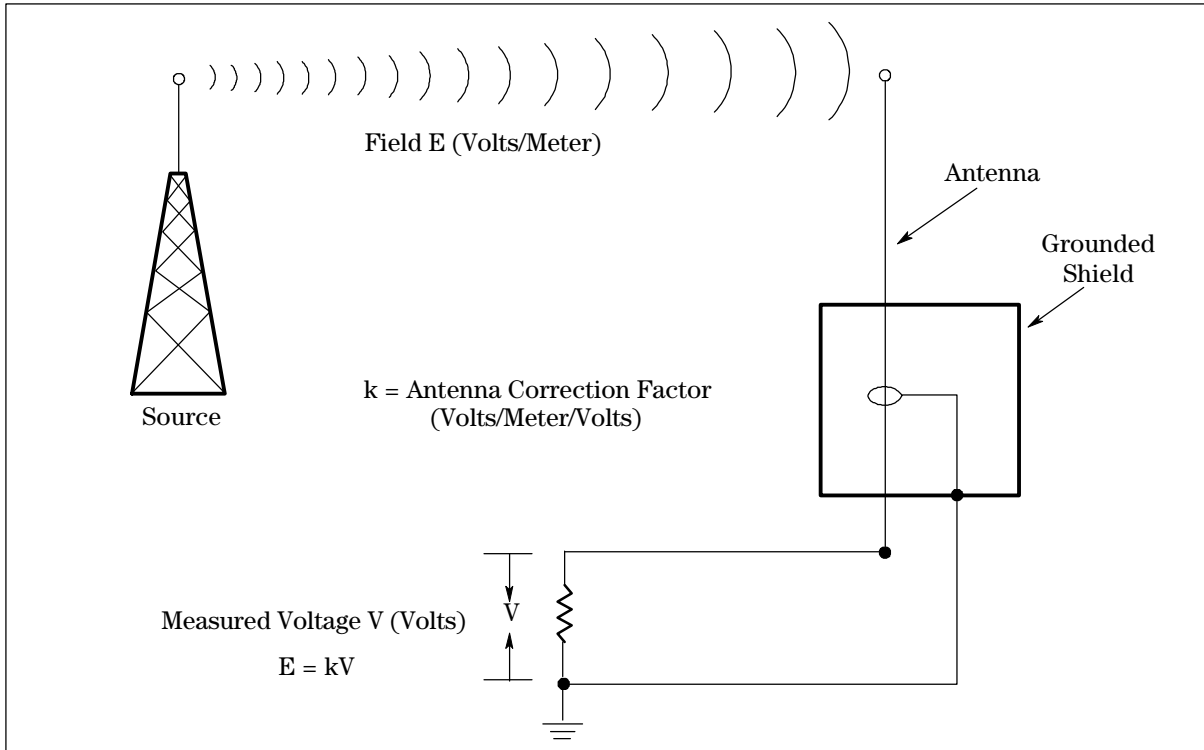
A convenient unit for V is dB $\mu$ V. So if we convert this equation to dB referenced to a microvolt,

$$E\left[\frac{\text{dB}\mu\text{V}}{\text{meter}}\right] = K\left[\frac{\text{dB}}{\text{meter}}\right] + V(\text{dB}\mu\text{V})$$

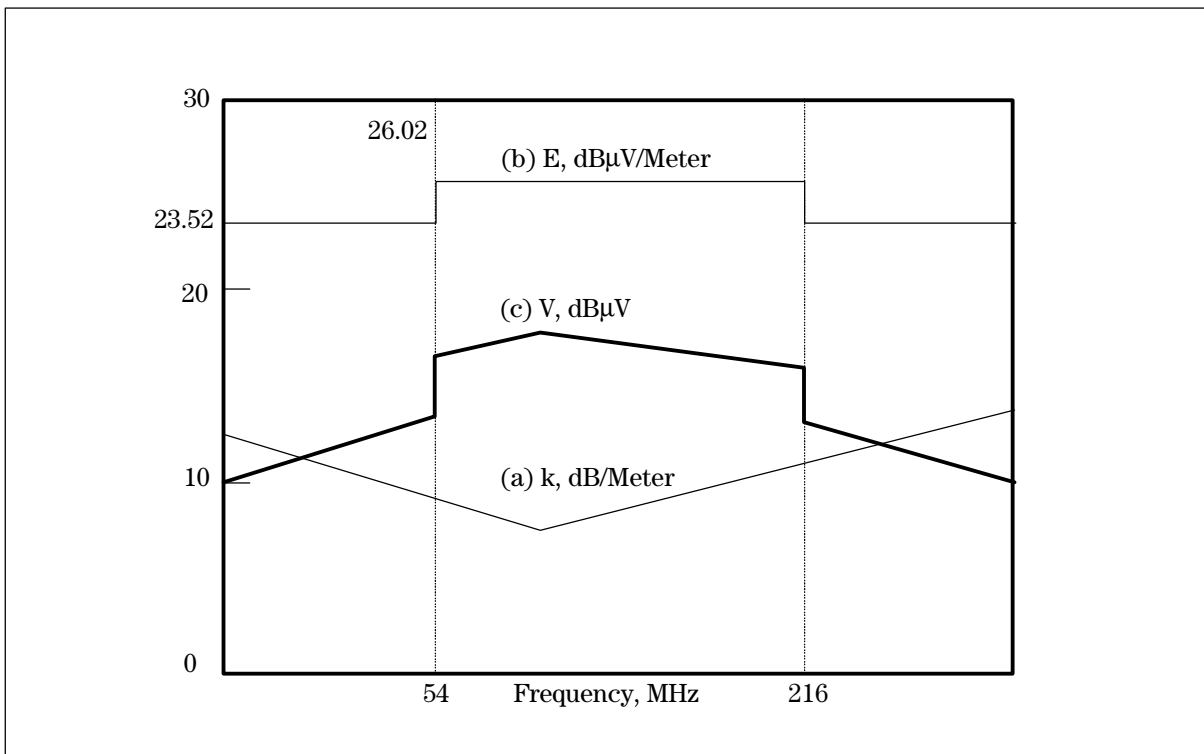
**K VARIES WITH  
FREQUENCY AND IS  
UNIQUE FOR EVERY TYPE  
OF ANTENNA**

The manufacturer's specifications for an antenna will include a table that shows the antenna correction factor, K, versus frequency in dB/meter. Then the E field is equal to the antenna voltage V, in dBV, plus the correction factor K, in dB/meter. It is convenient to graph the correction factor and on the same graph plot the E field spec limit from the radiation test of interest. Plotting the difference of these, namely E - K, results in a plot of the maximum allowable level in terms of receiver voltage for this particular radiation test. It is now only necessary to plot test receiver voltage on the same graph to determine whether the radiation exceeds the spec level; no conversion to dBV/meter is necessary. Figure 2.19 shows an example.

Instead of antenna factor, some antenna manufacturers characterize their product with isotropic power gain versus frequency. Antenna factors can be derived from gain using:



**Figure 2.18.** Radiated measurement terms.



**Figure 2.19.** Test levels for a particular radiation specification can be put into units of receiver voltage by plotting a) the antenna correction factor in dB/meter, b) the test limits in dBV/meter and c) the difference, b) minus a) in dBV. When a preamplifier is used to increase receiver sensibility the gain must be added to curve c) for proper calibration.

## K CAN BE DERIVED FROM ANTENNA GAIN

$$K = 20 \log f - 10 \log G - 12.79 - 10 \log Z_0$$

where  $K$  = antenna factor, dB/meter  
 $f$  = frequency, MHz  
 $G$  = antenna gain, unitless power ratio  
 $Z_0$  = receiver input impedance, ohms

For 75Ω input impedance:

$$K = 20 \log f - 10 \log G - 31.54$$

Measuring radiated signals in the presence of strong broadcast signals at the same frequency is not possible. Only signals unique to the CATV distribution system can be used to evaluate the system's radiation. There are usually a number of pilot tones and translated TV channels that can be used to characterize the system.

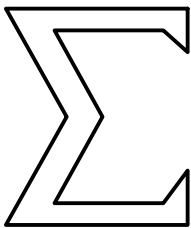
---

## In Summary

**Network analysis** measurements characterize a circuit's behavior with a given signal. **Signal analysis** measurements define a signal, regardless of its source. CATV system behavior is characterized more as a signal than a network measurement.

Signals are characterized by **frequency** (accuracy and stability), **level** (voltage, power, the logarithmic form of power, dB, and flatness) and **noise** (density, bandwidth, and signal to noise ratio).

CATV signals are defined and specified in terms of **frequency** (carrier accuracy), **level** (adjacent carriers, channel frequency response and absolute power) and **noise** (carrier to noise ratio). Extra signals in the CATV spectrum are **interference** (low frequency, such as hum and coherent disturbances, such as CTB, CSB, and crossmod). **Radiation** is the CATV system interfering with communications outside the system.



PARAMETERS

# Chapter 3

## Test Instrumentation

Now that the various measurement parameters have been reviewed, let's summarize the equipment and suitability for CATV system performance testing.

---

### Network And Signal Analysis

Types of electronic measurements generally fall into two categories, network analysis and signal analysis. Network analysis measures how a known signal is changed by a specific circuit. Signal analysis measures signal parameters without regard to the circuit. Since CATV measurements are primarily measures of signal quality rather than circuit analysis, signal analyzers are the recommended tools for installation, service and maintenance.

---

**SIGNAL ANALYSIS IS THE MOST VALUABLE TECHNIQUE IN CATV SYSTEMS**

---

### Instrumentation

Signal analysis instruments come in a great many forms. Here is a list of those you will be most familiar with:

- \* frequency counter
- \* oscilloscope
- \* power meter
- \* AC voltmeter
- \* field strength meter
- \* spectrum analyzer
- \* spectrum viewer
- \* noise figure meter

Each are capable of measuring one or more of the parameters on our familiar amplitude versus frequency plot. Frequency can be measured by all but the noise meter, AC voltmeter and power meter, and power amplitude can be measured on all but the frequency counter.

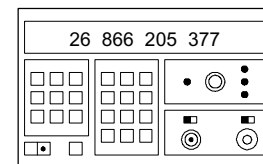
To understand how each of these instruments makes its specific signal analysis measurement, let's use the circuit and signal spectrum of Figure 3.1 which displays test points and the resulting signal spectrum.

The *frequency counter* measures and displays the frequency of a single signal. It does this by counting the number of cycles the input signal goes through during a very accurately timed interval. This number of cycles is then scaled to display the frequency in Hertz. See Figure 3.2. At test points 1 and 2 of Figure 3.1, the counter will read 30 MHz and 5 MHz respectively if the signal level is high enough to be counted. At point 3, however, the three higher level signals, 35 MHz, 25 MHz and 30 MHz,

---

**SIGNAL ANALYZERS MEASURE:**

- **FREQUENCY**
- **LEVEL**
- **OR BOTH**

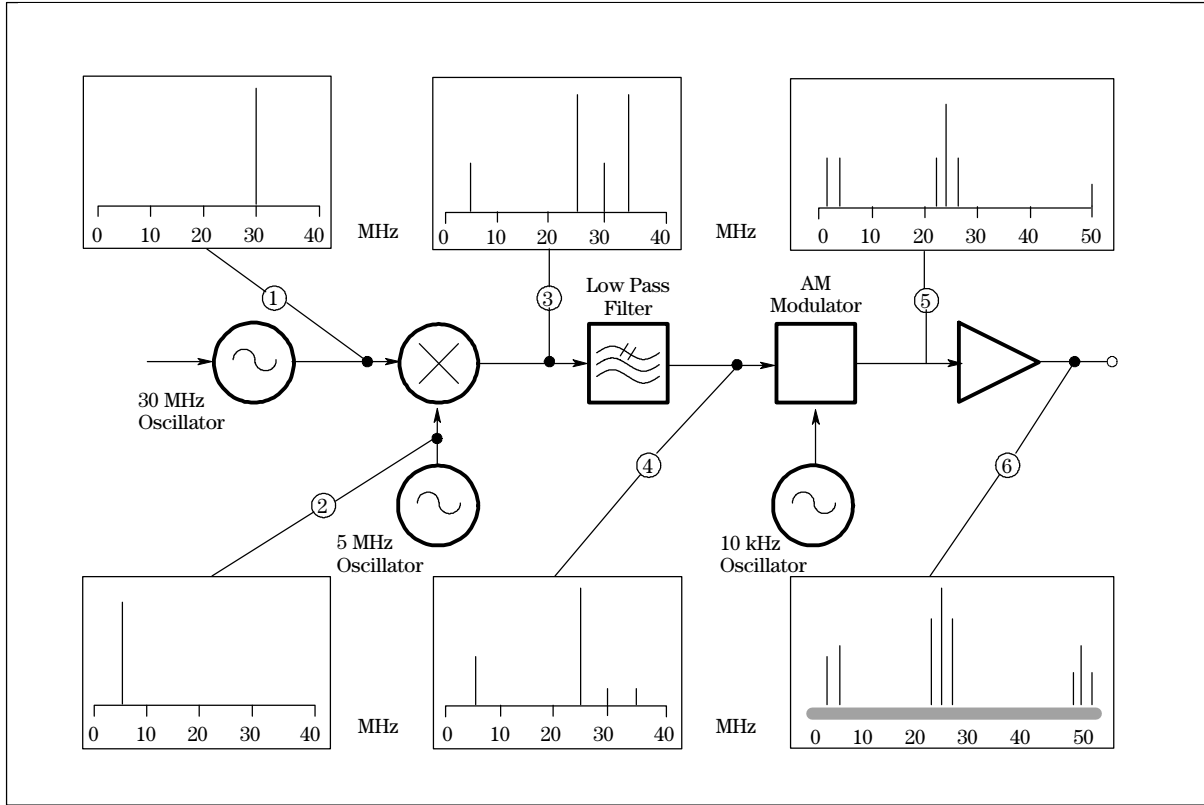


**FREQUENCY COUNTERS CAN MEASURE:**

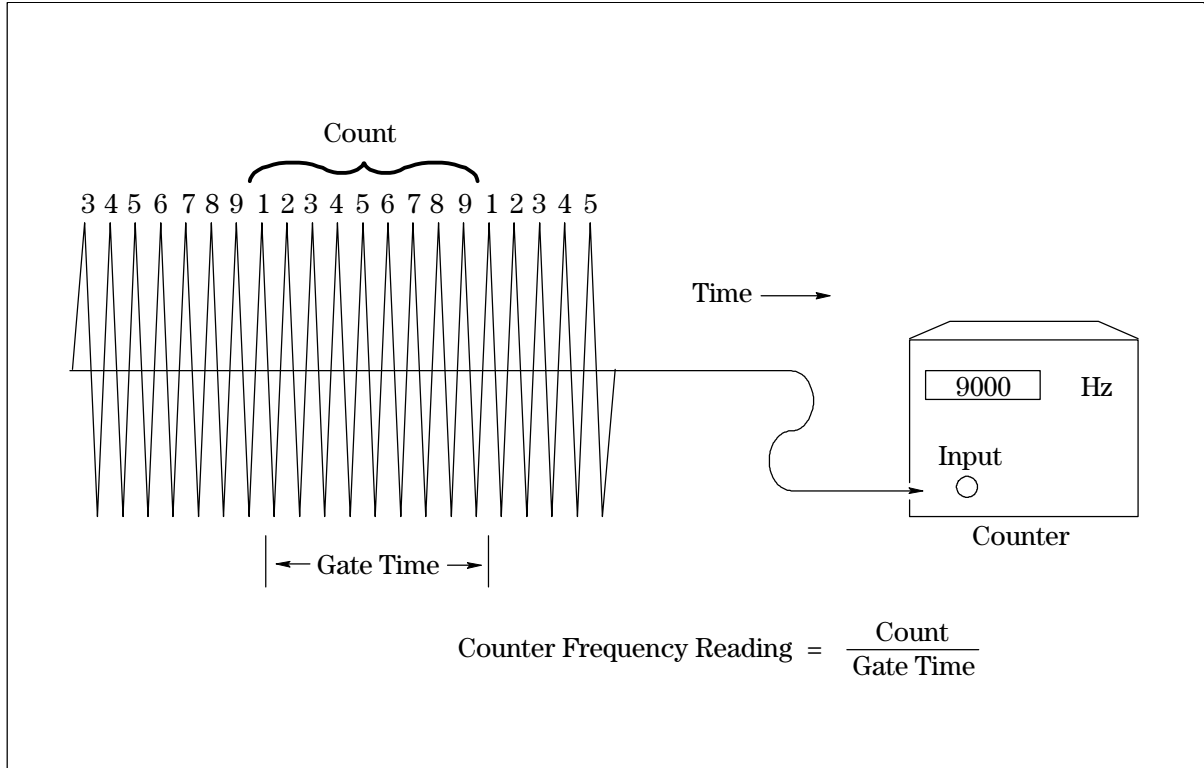
- **VERY ACCURATELY**
- **VERY FAST**

**CANNOT MEASURE:**

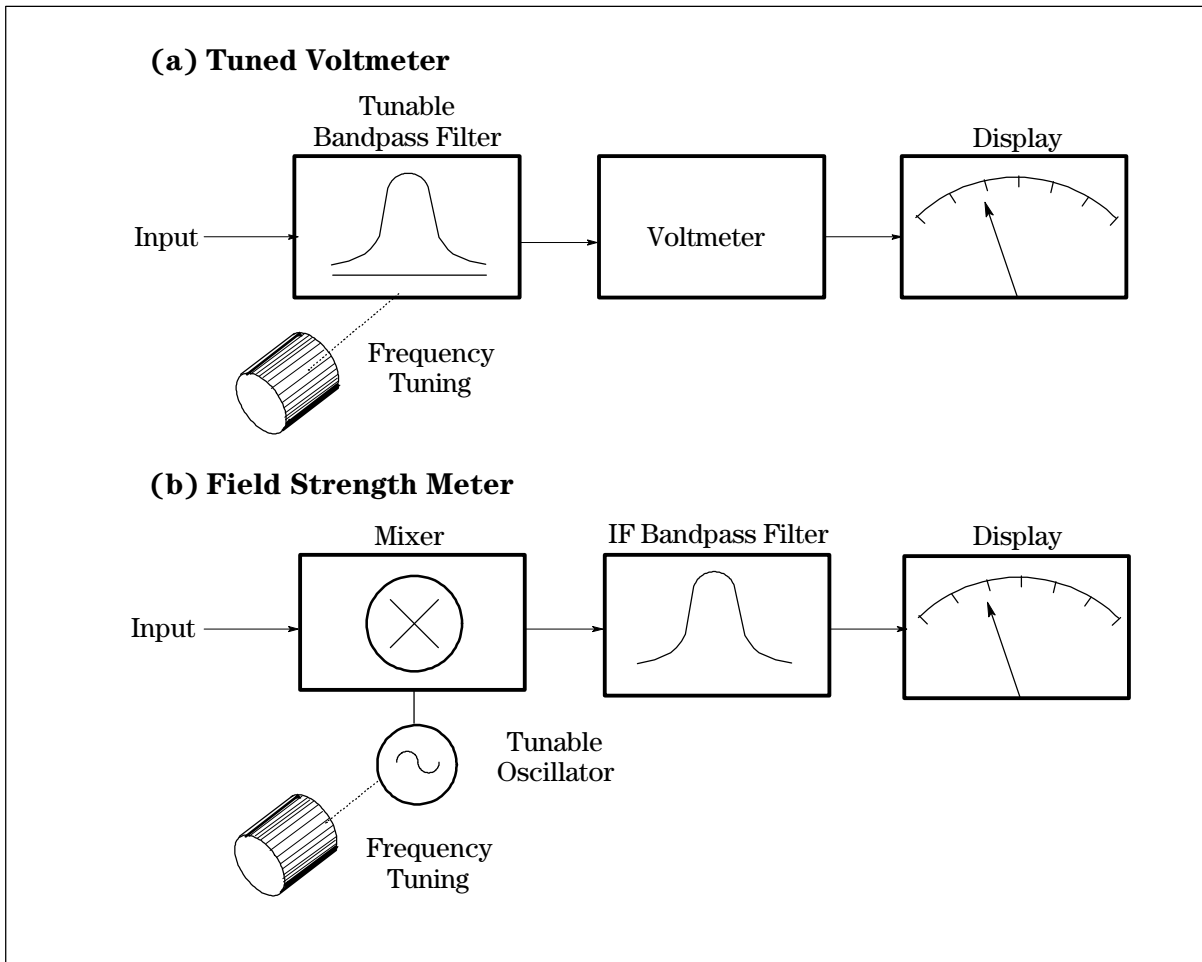
- **MORE THAN ONE SIGNAL AT A TIME**



**Figure 3.1.** Sample circuit with test points, and resulting signal spectrum.

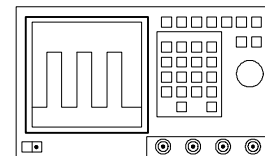


**Figure 3.2.** Frequency counter principle. The counter counts the number of cycles in the input signal for a specific period of time, called gate time. A microprocessor translates this into frequency. For example, if the gate time were 1 millisecond the 9 counts in the gate would read  $9/10^{-3} = 9 \text{ kHz}$ .



**Figure 3.3.** Tuned AC voltmeter and field strength meter. Two design approaches are used to make an AC voltmeter frequency sensitive (tunable). a) a tunable bandpass filter is placed in front of a broadband AC voltmeter. b) Input signals are mixed with a reference oscillator to provide an intermediate frequency (IF) signal which is then measured.

would cause extra counts in the counters timed interval resulting in a false reading. (Some modern counters can "tune-in" to the strongest signal.) Similar problems occur if the signal is modulated as in test point 5.



Counters are extremely accurate, more than enough to make CATV frequency measurements. Tapping off converter oscillator frequencies directly before mixing or using a tunable bandpass filter in front of the counter will assure accurate readings. When measuring modulated carrier frequencies the bandpass filter must be narrow enough to exclude most of the 15 kHz sidebands. An FM modulated audio carrier would require a wider bandpass filter and long counter gate times to average out the effects of the FM.

The *oscilloscope*, which provides a CRT picture of the actual signal voltage waveform in the time domain, is used most often as a waveform monitor to inspect TV video characteristics. Since all signals at the input are presented simultaneously on the display, it is difficult to discern any individual signal's voltage or frequency.

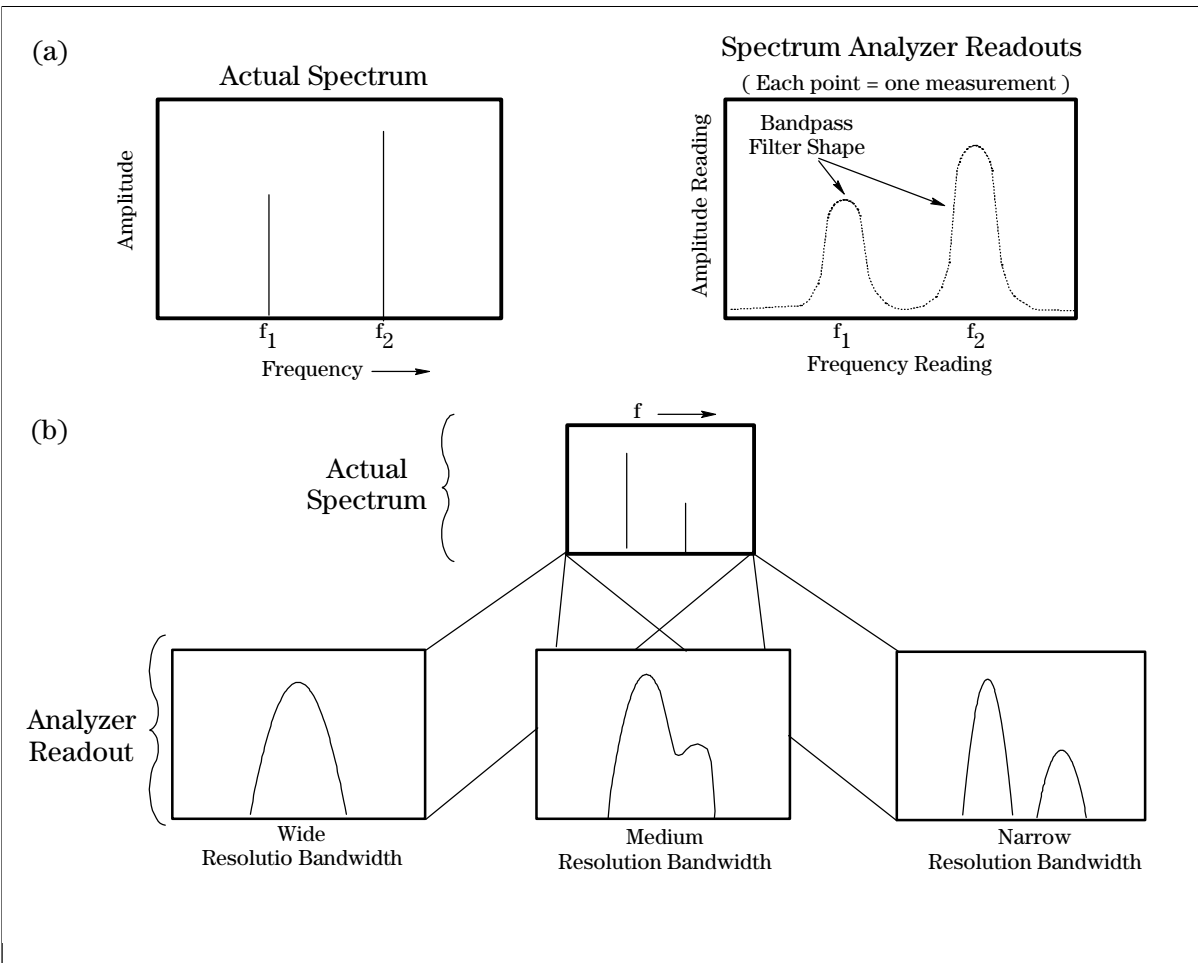
**WAVEFORM MONITORS  
CAN MEASURE**

- MODULATION ENVELOPE

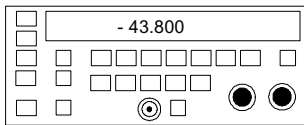
**CANNOT MEASURE:**

- FREQUENCY
- CARRIER LEVEL





**Figure 3.4.** Bandwidth and resolving power of tuned signal analyzers. a) Shows how the analyzer perceives signals in a spectrum. b) The effect of progressively narrower bandwidths on the same signal. The narrower the filter the closer the output display resembles the actual spectrum.



The *AC voltmeter* and *power meter* measure the rms or peak voltage and power respectively, of a signal input. Neither instrument is frequency selective, except for their measurement range or the use of a bandpass filter. If the voltage or power at test point 5 of figure 3.1 were measured, the reading would lump the powers of all the frequency components together. This makes them required tools for all total power measurements, such as transmitter power output. The amplitude measurements of single frequency sources can be very accurately measured.

If a tunable bandpass filter were placed at the input of a voltage or power meter, specific signal voltages and powers could be measured. Such an instrument is called a *tuned voltmeter*. Tuned simply means the amplitude measurement has been made frequency sensitive. The *field strength meter* is a tuned voltmeter (See Figure 3.3.)

The display for these instruments is usually a meter for amplitude and a dial or digital readout for frequency. Thus the instrument *measures a voltage or power* for each frequency in its range. The spectrum of a signal can be characterized by taking point by point readings and graphing the data.

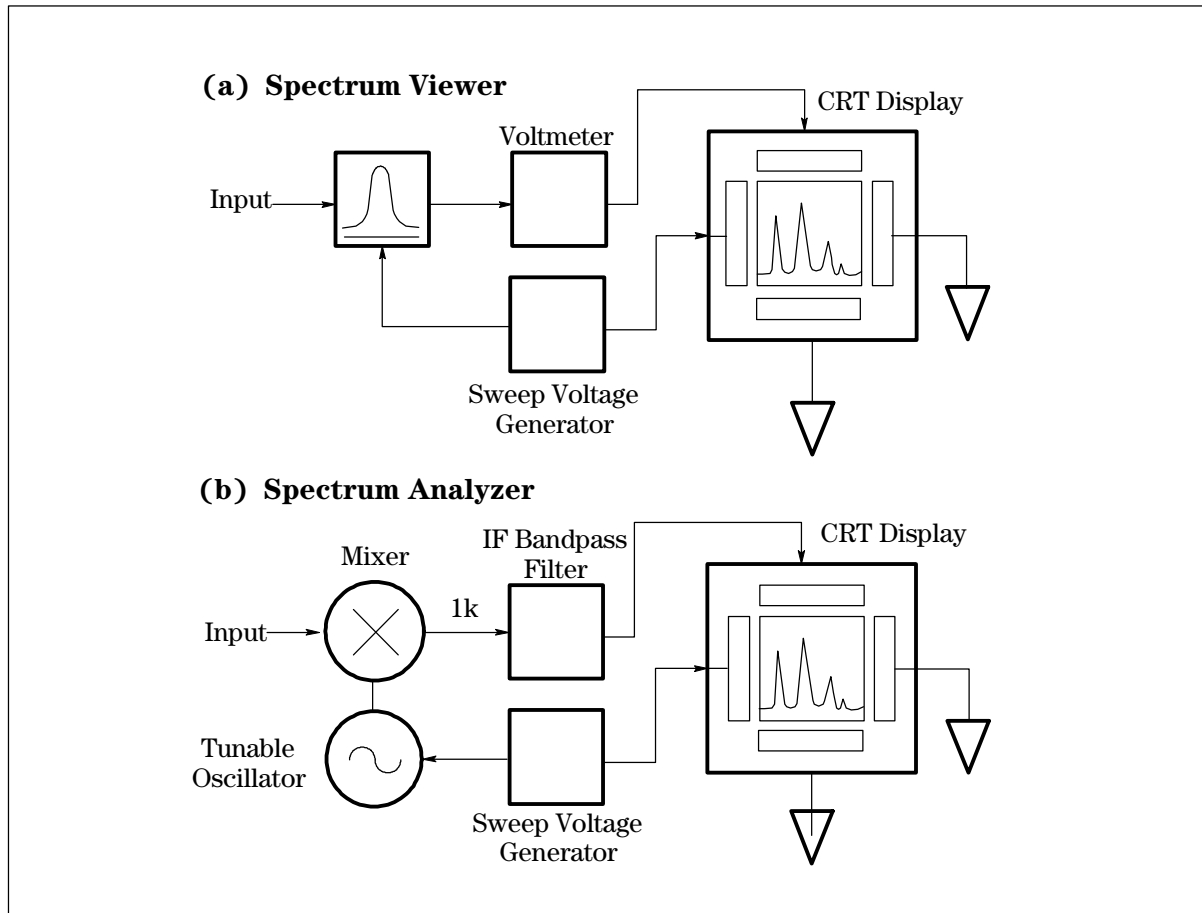
## POWER METERS

### CAN MEASURE:

- **TOTAL SIGNAL POWER**

### CANNOT MEASURE:

- **FREQUENCY**
- **POWER DIFFERENCE BETWEEN TWO**



**Figure 3.5.** Spectrum viewers and spectrum analyzers are automatically swept tuned voltmeters. The frequency range results are displayed on a CRT.

Tuned voltmeters are capable of making accurate CATV level measurements with narrow bandwidths. The narrow bandwidth is the "window" through which the analyzer sees a signal. The narrower this bandwidth can be, the easier it is to resolve close-in sidebands such as hum. Figure 3.4 shows how bandwidth helps resolving power.

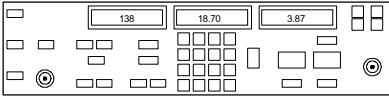
For measurement simplicity the frequency of the tuned voltmeter can be automatically swept so that a continuous readout can be displayed on an amplitude versus frequency plot. This so-called swept-tuned voltmeter method is the basis for the *spectrum viewer* and *spectrum analyzer*. See Figure 3.5.

The resolution concept applies to spectrum viewers, spectrum analyzers and manually tuned voltmeters. However, spectrum viewers have resolution and dynamic range limitations. Spectrum analyzers provide excellent spectrum displays for the measurement of CATV signals. Signal level, noise, sidebands, and interference can all be measured over narrow or wide frequency ranges. Instant insight as to the operation of the system and its components. The spectrum analyzer can be used as fixed tuned receiver for use with TV triggering and demodulation circuitry for video signal analysis. The *spectrum analyzer* with its built-in frequency counter can make very accurate frequency measurements of very low level signals, even in the presence of high level signals.

**FIELD STRENGTH METERS CAN MEASURE:**

- **INDIVIDUAL CARRIER AND SIDEBAND POWER**

**SPECTRUM ANALYZER: AN AUTOMATIC TUNED VOLTMETER WHICH DISPLAYS MORE INFORMATION FASTER**

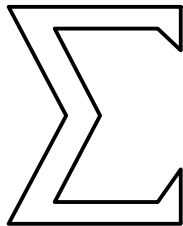


The **noise figure meter** is used to determine noise figure, not noise level. It measures the noise contribution made by an amplifier and not the noise being generated, as from a CATV system. The **noise meter**, or **signal strength meter**, makes absolute noise power measurements. It is a specialized test instrument which is generally used to make radio frequency interference (RFI) measurements to insure electromagnetic compatibility between different pieces of equipment.

---

## In Summary

Most of the familiar CATV test instrumentation are **signal analyzers**.



**Instruments**

The **counter** measures the frequency of a single frequency signal. The oscilloscope (waveform monitor) provides an amplitude (voltage) versus time display of a signal, The **AC voltmeter** and **power meter** measure signal level over a wide bandwidth. The **tuned voltmeter** (wave analyzer and field strength meter) measures signal level at a specific frequency. The **spectrum analyzer** is an automatic tuned voltmeter capable of displaying a continuous spectrum. Modern spectrum analyzers have additional built-in circuitry: frequency counter, TV trigger, AM/FM demodulation, and impedance matching. A **noise meter** is used to determine absolute noise power density measurements.





# Chapter 4

## Performance Measurements With A Spectrum Analyzer

The modern spectrum analyzer is capable of making all CATV system measurements for proof-of-performance as well as for maintenance and troubleshooting. Spectrum analyzer features now include frequency counters, TV triggering, AM/FM demodulation with speaker, impedance matching, preamplification, TV monitor on the display, data storage and software for automatic measurements.

Because of the analyzer's native ability to view entire spectra, or detailed signal responses, it can give you insights into unusual signal conditions that could not be otherwise understood.

The purpose of this chapter is to familiarize you with the analyzer by guiding you step-by-step through the main proof-of-performance measurements, explaining along the way how to optimize spectrum analyzer controls for the most accurate measurement results. Each test has a brief test description including subjective TV receiver symptoms, desired test levels, a procedure for making the measurement with a spectrum analyzer, a list of spectrum analyzer options, other equipment requirements and some hints for improving accuracy and efficiency.

Tests include visual and aural carrier levels, frequencies and frequency stability, carrier interference and noise, depth of modulation, hum, in-channel frequency response, carrier-to-noise ratio, crossmodulation, and CSO/CTB intermodulation.

**Headend measurements** are carrier level, frequency and stability, carrier interference, depth of modulation, and in-channel frequency response. **Distribution measurements** include carrier level, frequency and stability, carrier-to-noise ratio, crossmodulation, CSO/CTB intermodulation, hum, in-channel frequency response and system frequency response.

**SPECTRUM ANALYZER  
CAPABLE OF ALL PROOF-  
OF-PERFORMANCE  
MEASUREMENTS**

### **THIS CHAPTER HAS**

- **SYMPTOMS**
- **TEST LEVELS**
- **MANUAL TEST PROCEDURES**

---

## Absolute And Relative Measurements

An **absolute** measurement yields a value that is in units of absolute amplitude, frequency, time, etc. It is a number that can be compared to an IEEE or international standard. Carrier level is an absolute measurement, in dBmV. **Relative** measurements are comparative measurements, that is, differences between some known or familiar signal. The values are usually dB, time, or frequency. The visual carrier provides the "familiar" signal by which many measurements are made. Aural carrier level and aural frequency difference are relative measurements.

**MOST PROOF-OF-  
PERFORMANCE  
MEASUREMENTS ARE  
RELATIVE TO VISUAL  
CARRIER PARAMETERS**

The spectrum analyzer provides a very reliable repeatable measurement of power, voltage, time and frequency. Specified accuracies are discussed thoroughly in the operating and service manuals delivered with your spectrum analyzer. The specification can be confirmed by performing the tests outlined in the manuals.

---

## Accuracy Considerations

There are a number of performance adjustment and correction routines built into the spectrum analyzer that use the front panel calibration signal. These are described in the analyzer's user guide. It is assumed the these tests and corrections are applied for the following measurement procedures.

---

## Suggested Equipment

The tests are performed with the following spectrum analyzer and options:

HP 8591C Cable TV Analyzer (includes HP 85721A described below)

or

HP 8591E RF Spectrum Analyzer, 1 MHz to 1.8 GHz -or-

HP 8593E Microwave Spectrum Analyzer, 9 kHz to 22 GHz

Option 001 75 $\Omega$  input impedance (HP 8591E)

Option 004 Precision frequency accuracy

Option 023 RS-232 interface

Option 301 AM/FM demodulator, TV sync, and fast sweep

Option H81: TV picture for NTSC

Option 711 50/75 $\Omega$  Matching Pad for 8593E Microwave Spectrum Analyzer

Accessories include:

HP 85721A CATV RF/Video Measurement Personality

HP 85711B CATV Measurements Personality - U.S. only

HP 85716A CATV Measurements Personality - International

HP 85916A CATV PC Software - International

HP 85905A 75 $\Omega$  Preamplifier

HP DeskJet Plus printer

HP 85711B CATV Measurements Personality provides the operating procedures in software for all proof of performance measurements. The following procedures do not use the CATV personality. Over the life of this handbook Hewlett-Packard will undoubtedly introduce new spectrum analyzers and options, the performance and procedures in this chapter remain valid for spectrum analyzers with comparable

---

**USE INTERNAL  
ANALYZER CORRECTION  
FACTORS**

---

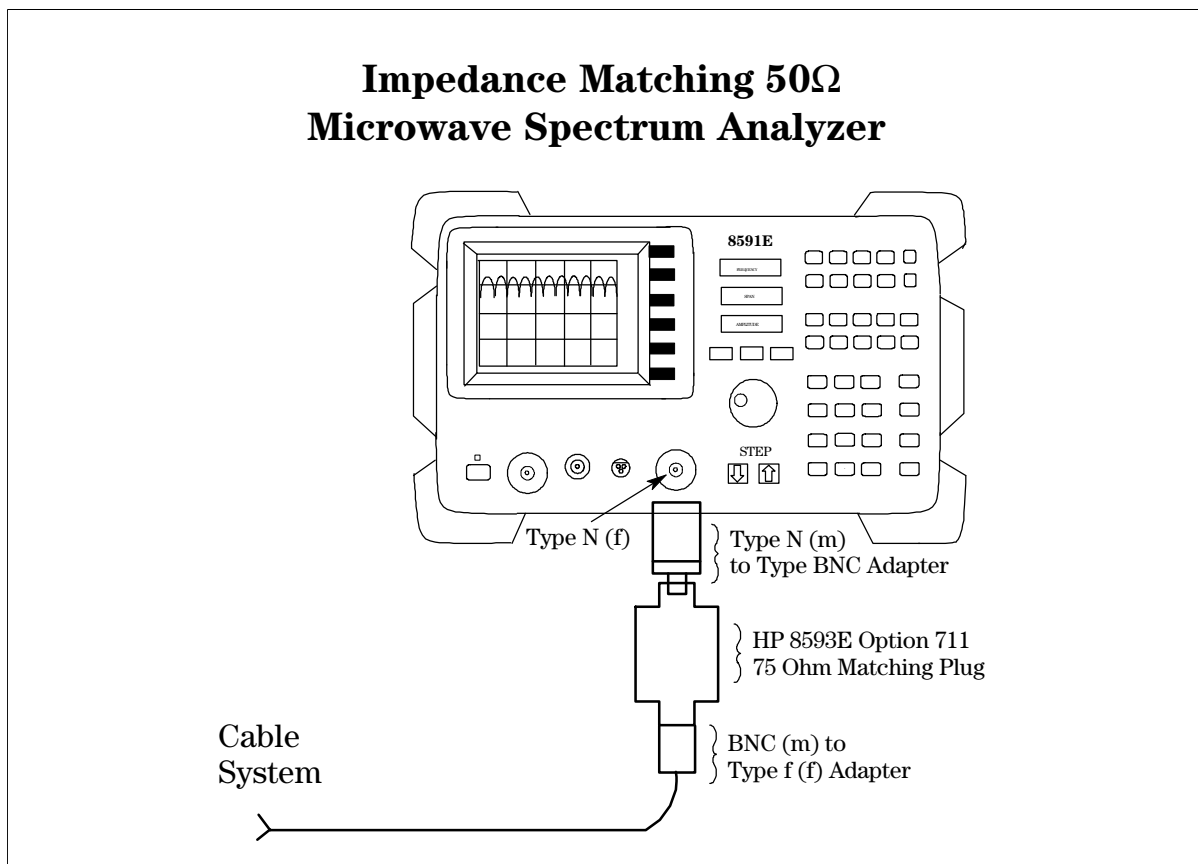
**HP MEASUREMENT  
PERSONALITY PERFORMS  
THESE TESTS  
AUTOMATICALLY..**

**...BUT THIS CHAPTER  
TEACHES MANUAL  
PROCEDURES**

### Please Note

Key strokes in the following procedures are identified by:  
PRESET - capital letters indicate a key on the front panel  
Next Peak - underline indicates a softkey, adjacent to the CRT

## Impedance Matching 50Ω Microwave Spectrum Analyzer



**Figure 4.1.** An impedance matching device is required for microwave spectrum analyzers or 50Ω RF analyzers.

performance to those listed. The handbook measurement procedures do not depend on software or measurement tools not found in the manual operation of the analyzer.

### Please Note

For all the measurements that follow, the analyzer settings are assumed to be set after either the PRESET or POWER ON buttons have been pressed.

## Before You Start

To make the following measurements your spectrum analyzer needs to be calibrated, as mentioned above, using its internal calibration signal. If your analyzer has a 50Ω input, a matching pad needs to be added, and the analyzer impedance set for 75Ω. The following measurements require that the units have been set to dBmV.

1. Set the input impedance to 75Ω by pressing AMPLITUDE More 1 of 2 INPUT Z 75Ω.
2. Set dBmV units by pressing AMPLITUDE More 1 of 2, dBmV.

**MAKE SURE YOUR  
ANALYZER IS  
CALIBRATED BEFORE  
PERFORMING ANY OF  
THESE TESTS**



---

## Full System Check

A spectral display of the entire system allows you to detect any major performance variations or disruptions. The clumps of channel allocations quickly shows the type of channel allocation: HRC, IRC or Standard.

Set the spectrum analyzer as follows (key strokes are given below):

Frequency:

Start: 30 MHz

Stop: 450 MHz

Resolution Bandwidth: 100 kHz

Video Bandwidth: coupled

Sweep time: coupled

Marker(s): none

Amplitude:

Reference Level: highest signal below Reference Level

Attenuator: 0 dB provided highest level signal is below  
45 dBmV

Scale: 10 dB/division

Units: dBmV

For the analyzer specified, here is how to set each of the above parameters:

1. For the frequency parameters press PRESET to bring the analyzer to a known state. Press FREQUENCY START 30 MHz, STOP 450 MHz, BW 100 kHz.
2. To set the amplitude press AMPLITUDE and use the knob to set the highest level signal to just below the top graticule, the REF level.
3. If the reference level is less than 45 dBmV, go to the next step. If the signal at the tap is lower, the analyzer viewing range can be increased by setting the attenuator to zero dB by pressing AMPLITUDE Atten 0 dB.

**Please Note**

From this point on instructions will not be given for the starting setup.

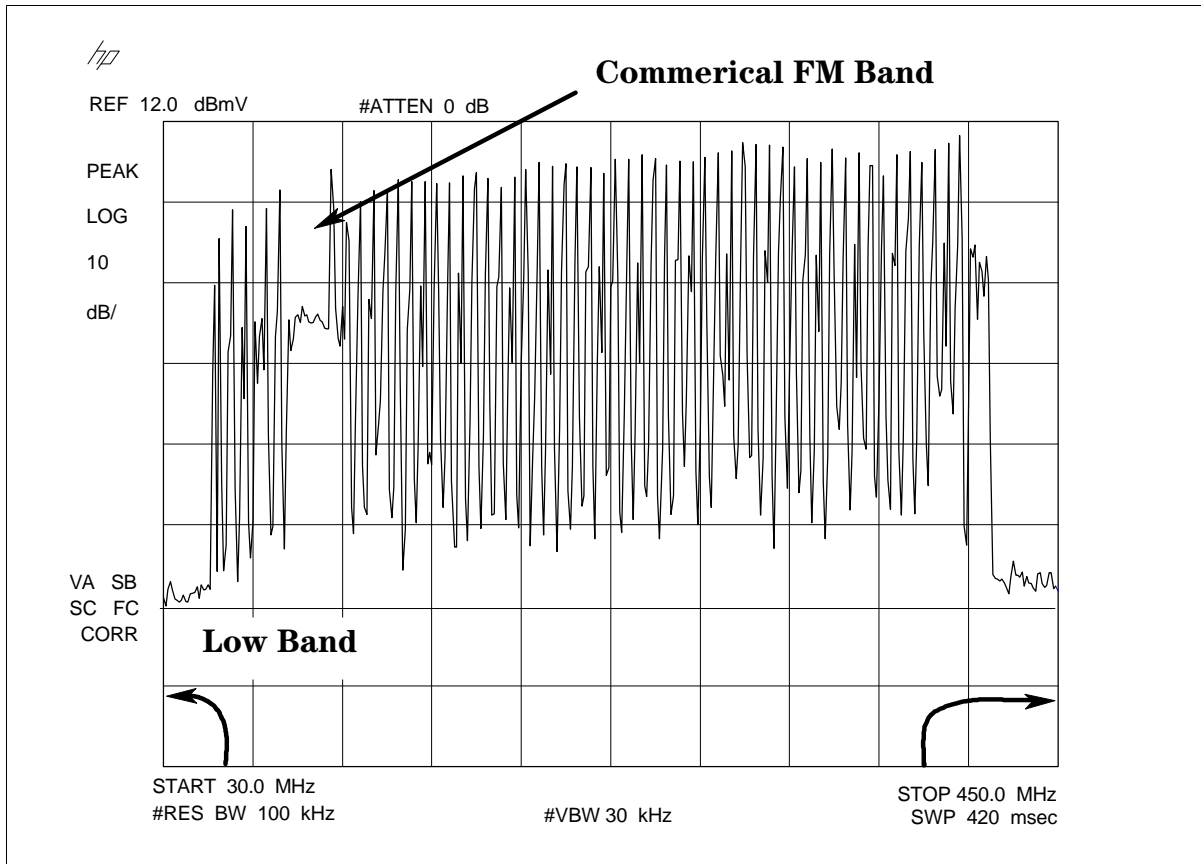
**FULL SPAN NOT FOR  
TESTS, BUT FOR A  
QUICK LOOK**

In Figure 4.2 the visual carriers can clearly be seen. A different resolution bandwidth must be used for accurate amplitude measurement which will be explained later, so don't worry about system frequency response or suckouts. This display simply provides a quick look at the system operation.

---

## Visual and Aural Carrier Level and Frequency

The objective of this test is to measure the absolute power levels of each carrier and the relative levels of their aural sidebands at a subscriber tap terminated in its characteristic impedance. It is critical to use 75Ω impedance for accurate levels.



**Figure 4.2.** The full span of a Standard cable system with 55 channels, 5 in the low band and 50 above. Commercial FM is also visible from 88 MHz to 108 MHz.

**Please Note**

Unless otherwise directed, a Standard channel 2 will be used for all channel specification measurements.

1. Set the spectrum analyzer as follows:

Frequency:

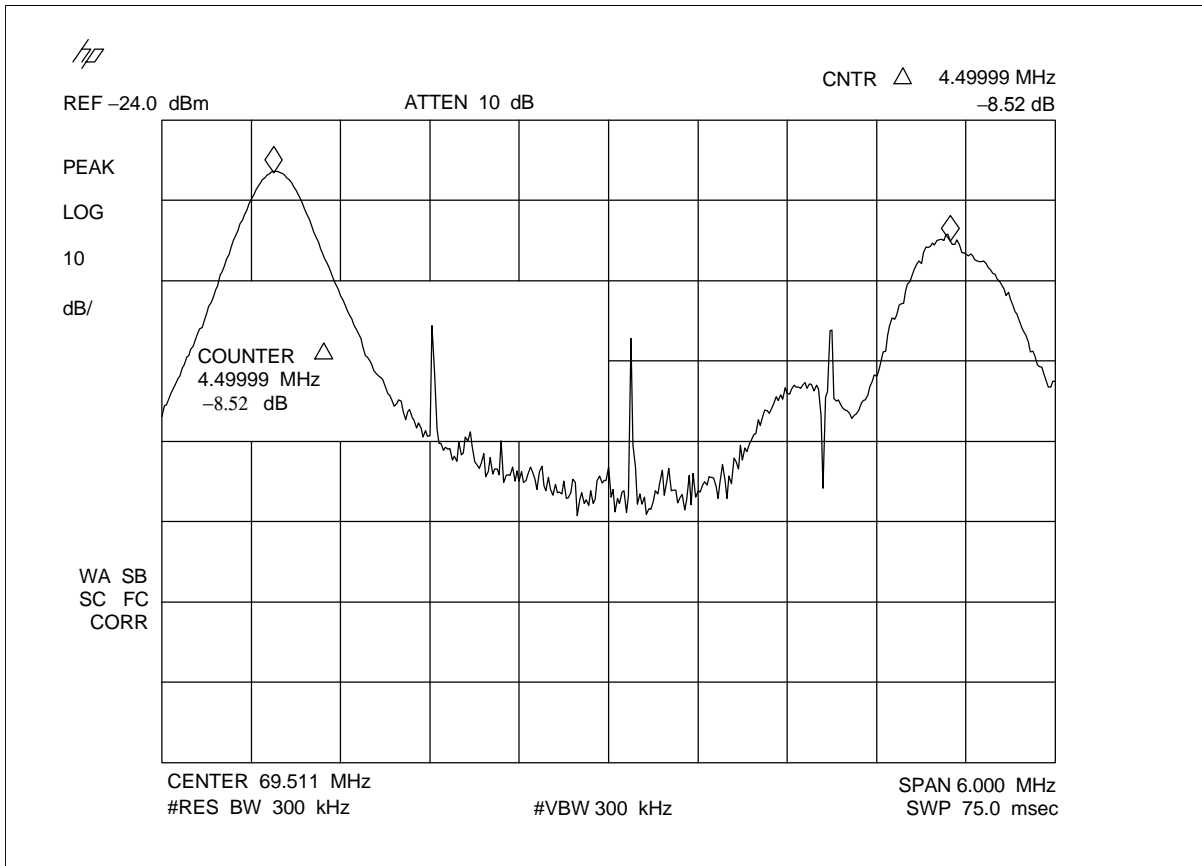
Center: 57.3 MHz  
 Span: 6 MHz  
 Resolution Bandwidth: 300 kHz  
 Video Bandwidth: coupled  
 Sweep time: coupled

Amplitude:

Reference Level: highest signal below Reference Level  
 Attenuator: 0 dB provided highest level signal is below 45 dBmV  
 Scale: 10 dB/division

2. Trace out the maximum trace path with TRACE MAX HOLD A VIEW A and press PEAK SEARCH to read the value in dBmV. This **absolute** level is the power of the visual carrier. Tap levels should be above 0 dBmV.
3. Activate the frequency counter to increase frequency measurement accuracy: TRACE Clear Write A MKR FCNT (which stands for

**FREQUENCY MEASUREMENTS ARE REQUIRED IF YOUR SYSTEM TRANSLATES ONE CHANNEL TO ANOTHER**



**Figure 4.3.** Channel 2 displayed in a 6 MHz span with the markers displaying the aural carrier level and frequency compared to the visual carrier. The analyzer's frequency counter is necessary to provide the required frequency accuracy.

marker function) **MK COUNT ON**. The counter resolution is set to 1 kHz and the display shows a readout to tenths of kHz: 55.2600 MHz. This is sufficient for measurement resolution, however, one more decade of resolution can be achieved by setting the counter to 100 Hz resolution: **More 1 of 2 CNT RES** (for counter resolution) 10 Hz.4. Now measure the relative frequency of the aural carrier with a second marker activate **MKR MARKER Δ** and place the marker at the aural carrier and read the difference frequency as 4.9999 MHz, well within the 4.5 kHz specification.

4. The aural carrier is measured relative to the visual carrier. A second marker relative to the first is used to make this measurement. Press **MARKER Δ** and move the marker to maximum of the aural carrier on the right with the knob or **Next Peak**. Read the aural carrier in the upper right of the display.

**Please Note**

If your channels are spaced by 6 MHz, you can use the analyzer's frequency step size to allow you to jump to each successive channel with one key stroke. Press **FREQUENCY CF STEP 6 MHz**, then **Δ** or **∇** while in the **FREQUENCY** menu will move you to the next upper or lower channel respectively.

---

## Measuring C/N With The Spectrum Analyzer

The measurement of C/N is two steps. First, measure the carrier peak. This was covered in the previous sections. Second, measure the noise and compare the two as a power ratio in dB. Here is how to measure noise power density with the spectrum analyzer.

Noise appears as a fuzzy, constantly moving baseline on the analyzer's display. This noise can be from inside the analyzer (after all the spectrum analyzer is a collection of components including amplifiers) from the system or from a combination of both internal and system noise.

To quickly determine whether displayed noise is coming from the input or being generated by the analyzer simply pull off the input signal from the front panel. If the noise level drops by about 10 dB or less, there is significant noise being input. Noise from the spectrum analyzer requires a correction to the reading.

If the noise drop is less than 1 dB you will have to increase the sensitivity of the analyzer with a preamplifier. Adding a preamplifier with a low noise figure reduces the effect of the analyzer's noise on the system noise. A preamplifier also increases the power of the cable signal by its gain. This means that the analyzer could be subject to overload. As you recall from the section on measuring the video carrier level, page 2-6, overload causes significant measurement uncertainty. If computation of the power levels indicates that overload will be a problem, the simplest solution is to increase the analyzer input attenuation until the carrier is not compressed. With a measurement range of 36 to 46 dB, and a spectrum analyzer measurement range of about 85 dB, the attenuator can be set to as much as 30 dB before a bandpass filter is required to limit system power to the analyzer. The following figure shows the setup if a band pass filter is required.

After adding the preamplifier perform the noise test again. This time remove the input signal at the PREAMPLIFIER, not at the spectrum analyzer. Now the preamplifier and the spectrum analyzer together comprise the noise measurement instrument, not just the analyzer. Corrections for noise near noise are applied as if the analyzer alone were making the measurement. The next section covers this process in detail.

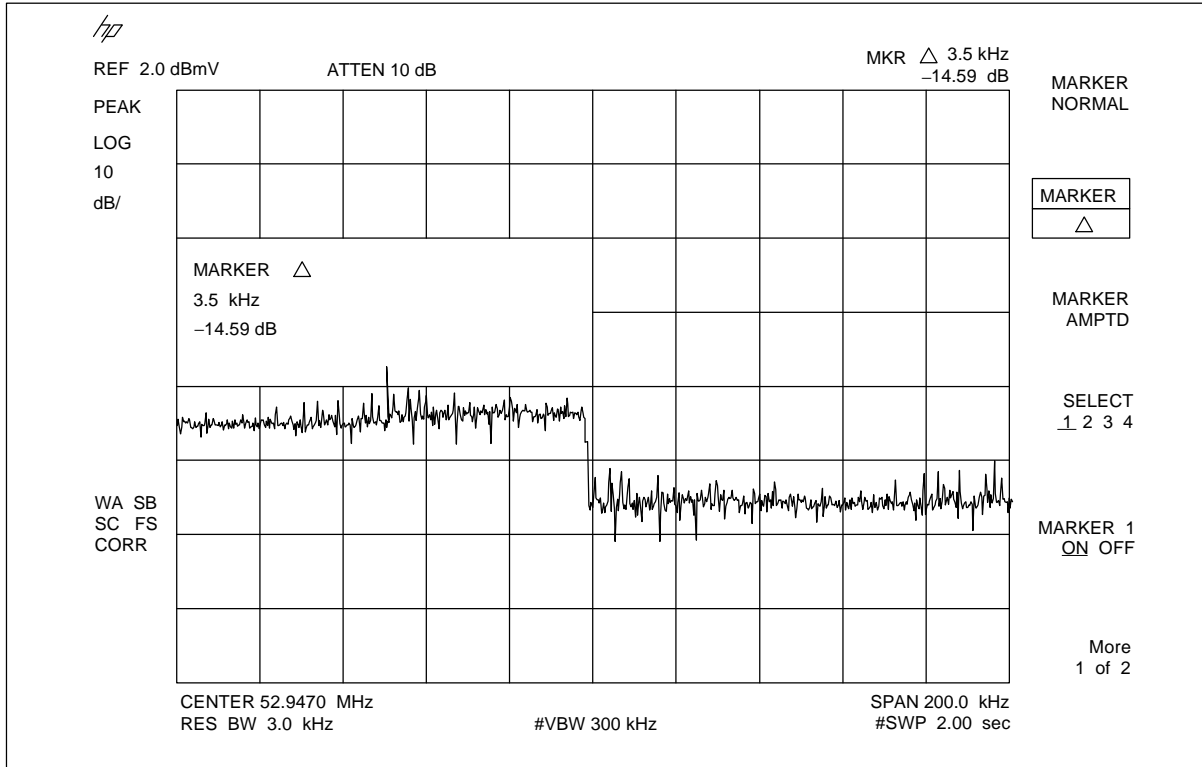
---

## Corrections Required to Measure Noise Power Density

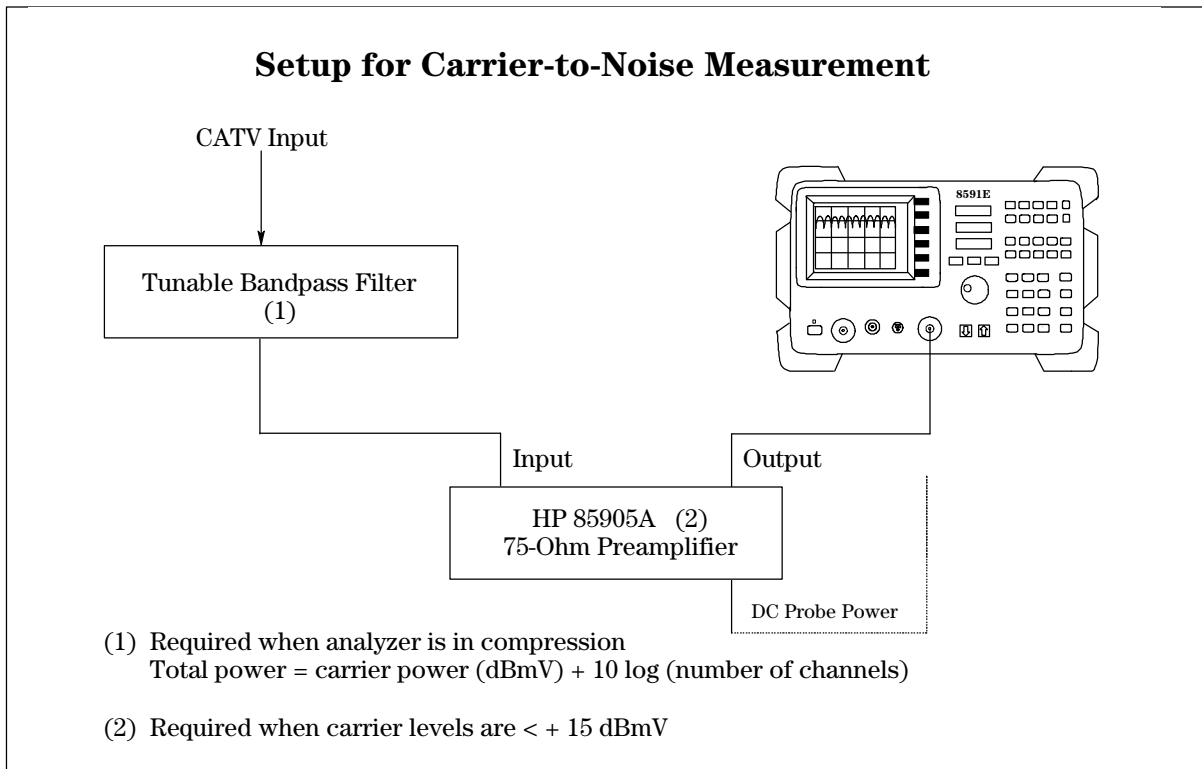
There are four corrections for noise power density:

- 1) Adjusting noise power reading for 4 MHz bandwidth reference
- 2) Noise-equivalent bandwidth
- 3) Analyzer or analyzer plus preamplifier noise figure
- 4) Log detected noise correction

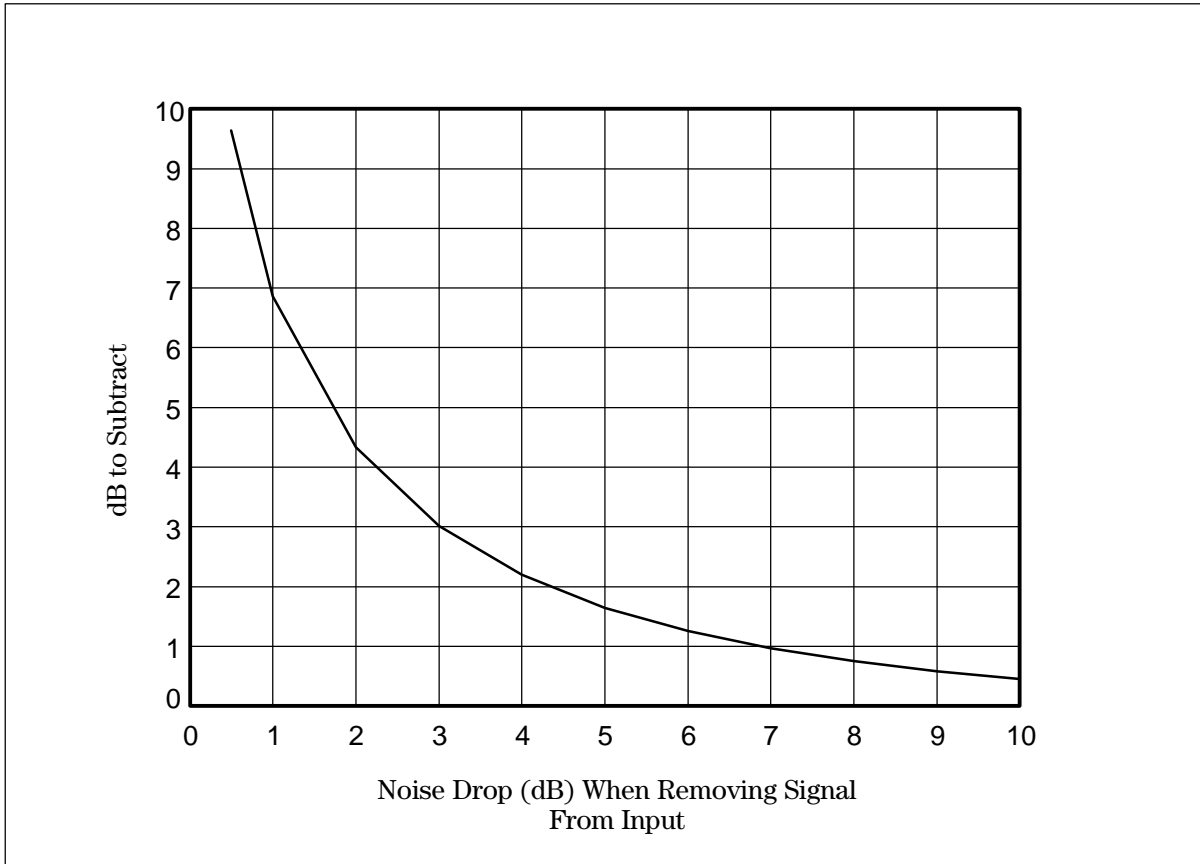
**SPECTRUM ANALYZER  
CONTRIBUTES NOISE  
TOO**



**Figure 4.4.** A significant drop of noise when the input connection is broken indicates the presence of system noise.



**Figure 4.5.** Getting required sensitivity for C/N measurement without overloading the analyzer.



**Figure 4.6.** Correction to readings of noise level when input noise is within 10 dB of analyzer noise.

All these correction values reduce to one error correction value, in dB, so don't let their derivation be discouraging. Let's look at each term.

**4 MHz bandwidth correction:** This from the equation on page 2-11. If the analyzer bandwidth is always set to 30 kHz then the correction factor will be  $10 \log(4 \times 10^6 / 30 \times 10^3) = 21.25$  dB. If you measure a noise power in the 30 kHz resolution bandwidth, add 21.25 dB to the measured value to determine the noise power density in 4 MHz. Therefore, **SUBTRACT 21.25 dB** from the uncorrected C/N.

**PULL THE INPUT TO SEE IF SYSTEM NOISE CAN BE MEASURED**

Here is a table of the most frequently used bandwidths:

Spectrum analyzer resolution bandwidth (kHz)	1 MHz bandwidth correction (dB)
10	26.02
30	21.25
100	16.02
300	11.25

**Table 4.1.** Corrections to noise measurement for analyzer resolution bandwidths.

**NOISE CORRECTION:**

- **CONVERSION TO 4 MHz BANDWIDTH**
- **FILTER BW**
- **ANALYER NOISE FILTER**
- **LOG DETECTED NOISE**

**Filter noise-equivalent bandwidth:** The analyzer's bandwidth is not a perfectly square 4 MHz filter. It is a synchronously tuned filter so the measured noise power will be 1.127 times more than an equivalent ideal square filter. The correction is to subtract 0.52 dB from the measured value. ADD 0.52 dB to the uncorrected C/N measurement.

**Analyzer or analyzer plus preamplifier noise figure:** If the noise of the system is not 10 dB greater than the analyzer noise, or the analyzer plus the preamplifier's noise, then the value will be a composite of input and analyzer noise. The reading will be too high. Figure 4.6 shows the correction. For example if the noise drops 3 dB when disconnecting the input, subtract 3 dB from the measured noise value. ADD 3 dB to the uncorrected C/N measurement.

**Log detected noise:** The spectrum analyzer is a voltmeter with log detection which allows signals of very wide power values to be viewed on the same display. The result of log detection is a reading too low by 2.5 dB, therefore, add 2.5 db. SUBTRACT 2.5 dB from the uncorrected C/N measurement.

---

## Measuring and Calculating Carrier to Noise

1. Setup the analyzer as in the Figure 4.5.
2. Adjust the analyzer to
  - Frequency:
    - Span: 6 MHz
    - Resolution Bandwidth: 300 kHz
    - Video Bandwidth: 300 kHz
    - Sweep time: coupled
  - Amplitude:
    - Reference Level: highest signal below Reference Level
    - Attenuator: 0 dB provided highest level signal is below 45 dBmV
    - Scale: 10 dB/division
3. Measure the carrier level as directed in the procedure on page 4-5. If the level is less than +15 dBmV add an appropriate preamplifier before continuing. The level read for carrier on the analyzer will still be valid, since noise power density will also be measured with the preamplifier in place.
4. Test for overload as outlined on page 4-17. Add input attenuation or a bandpass filter if necessary. If a bandpass filter is added it may be necessary to repeat step 3, making sure that the carrier is measured at the peak of the bandpass filter response.
5. Set BW VID BW 10 kHz, SPAN 1 MHz. Readjust the carrier to the center of the display.
6. At the headend, turn off the carrier from the channel under test making sure all headend channel noise contributing devices remain in the signal path. For off-air channels, disconnect the antenna lead to the processor and terminate the processor input. For other channels, disconnect the first access to the baseband video signal and terminate the input.
7. Tune the spectrum analyzer up 2 MHz to center the noise measurement on screen: Press FREQUENCY STEP SIZE 2 MHz, FREQUENCY  $\Delta$ . If using a bandpass filter, carefully adjust it to peak the noise at the center frequency.

**TEST FOR OVERLOAD  
CRITICAL**

**FCC C/N REQUIRES  
TURNING OFF CHANNEL  
UNDER TEST**

28. Use the MKR to read the dBmV of noise power.
9. Determine the effect of analyzer noise on the measurement of the input noise. Press MKR **MARKER Δ** and disconnect the input from the analyzer, or, if a preamp is use, from the input to the preamp. Read the noise change. Get the noise near noise correction from the curve in Figure 4.6.
10. Use the following table to compute the C/N.

## Computing C/N

This example will help understand the procedure used by the table:

1. The carrier is measured as +23.7 dBmV with a spectrum analyzer that has a preamp whose noise figure is 7 dB and gain is 15 dB. (You don't need to know the gain and noise figure for the computation, however.)
2. After turning off that channel's carrier, the noise level analyzer is measured -48.5 dBmV in a 10 kHz resolution bandwidth.
3. To determine whether the analyzer has enough measurement range the input signal to the preamp removed. The noise drops by 7 dB. From the noise near noise chart a correction of 1 dB is required. (Note that the input is removed from the INPUT of the preamplifier, not the analyzer. If no preamplifier was present, the analyzer input would have been removed.)
4. Compute the noise and carrier to noise ratio using the following table:

### C/N EXAMPLE

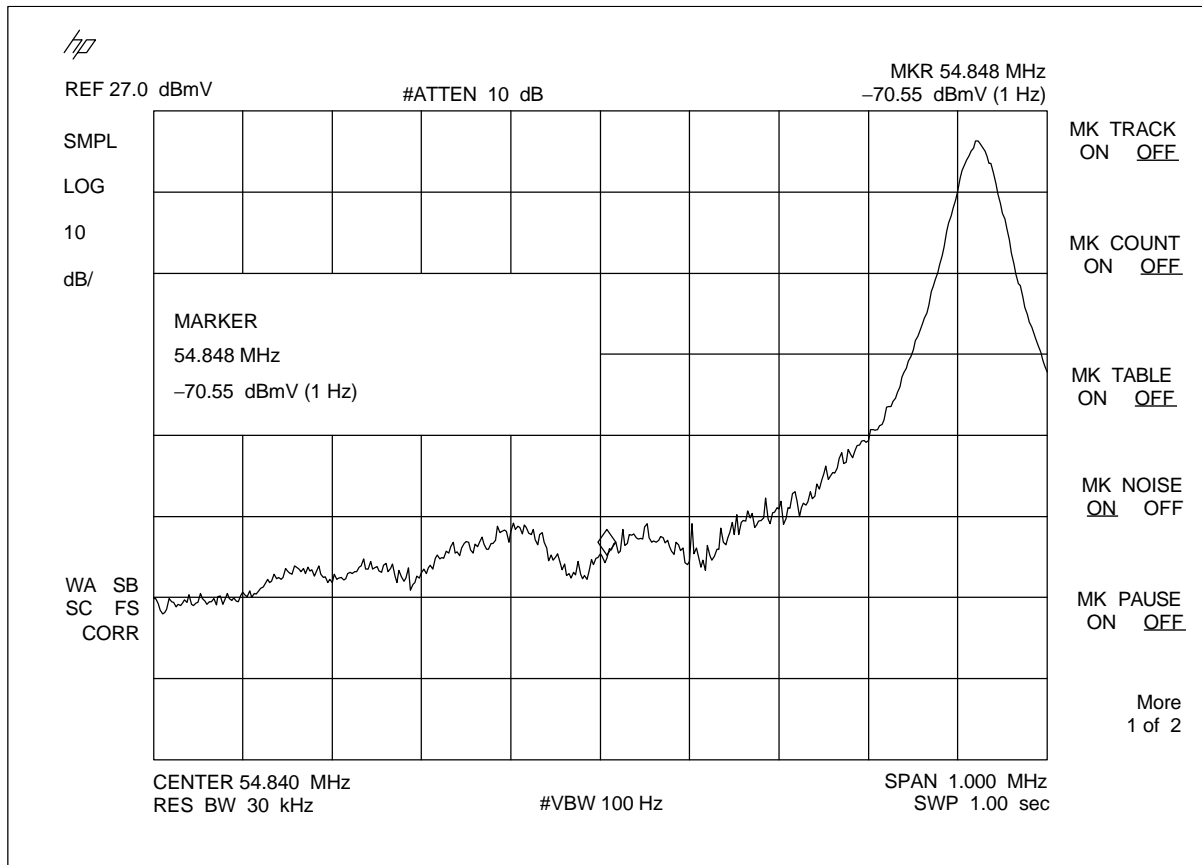
Step	Factor	Correction or value	Example
A	Carrier Level	_____ dBmV	+23.7 dBmV
B	Noise Level	_____ dBmV	-48.5 dBmV
C	Uncorrected C/N	A - B	72.2 dB
D	10 kHz to 4 MHz correction from Table 4.1	26.02 dB	26.02 dB
E	Noise BW and Log detection correction	1.98 dB	1.98 dB
F	Noise correction from Fig 4.6	_____ dB	1 dB
G	Corrected C/N	C - D - E + F	72.2 - 26.02 - 1.98 + 1 = 45.2 dB

**Table 4.2.** Fill in the table for calculating C/N.



## Quick Look C/N Measurement:

1. Select a channel whose vestigial sideband does not have an adjacent channel's aural carrier present. Channel 2 or 7 may be candidates in a Standard channel system. If the channel carrier is below +30 dBmV, add a preamplifier. Measure and record the visual carrier level as in the visual carrier amplitude test.
2. Test for overload. Since the analyzer is a wideband receiver the power at its input mixer can cause the carrier to appear below its actual level (analyzer compression). Note the carrier level change when changing the RF attenuator. If the signal level changes by more than 0.5 dB, use the higher attenuator setting or insert a bandpass filter as shown in Figure 4.5 and repeat steps 1 and 2.
3. Move to the vestigial side of the carrier with **FREQUENCY CF STEP** 400 kHz **FREQUENCY V** . Narrow the bandwidth to improve the noise sensitivity with **BW 30 kHz** **VID BW 100 Hz**. Measure with marker **MKR FCTN MK NOISE ON**.
4. Pull the input connector off the analyzer. If the noise drops by 10 dB or more, the noise registering on the analyzer is system noise. If less than 10 dB, the noise displayed has too much of the analyzer's own noise. The noise reading will have to be reduced by the value in Table 4.2.



**Figure 4.7.** The noise is measured 400 kHz below the carrier. The analyzer's noise marker function takes into account all errors except for converting to 4 MHz bandwidth.

5. The noise level is the noise marker reading corrected by the bandwidth conversion from 1 Hz to 4 MHz, that is:

$$10 \log(1/(4 \times 10^4)) = -46 \text{ dB.}$$

6. The C/N is the carrier level from step 1 – (reading in step 4 + 46 dB)

Here is an example:

Carrier level from step 1 = +22.5 dBmV

Noise level from step 4 = -70.55 (in 1 Hz bandwidth)

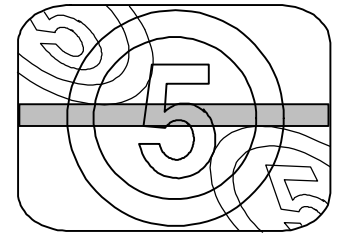
$$C/N = 22.5 - (-70.55 + 46) = 47.1 \text{ dB}$$

---

## Co-Channel and Ingress Interference

Co-channel and ingress are interference signals in the cable system caused from sources outside the system. Measurements record the relative power at the subscriber tap of interference signals to the visual carrier. Co-channel is always spaced in 5kHz AND 10 kHz increments away from the carrier. An ingress interference signal can be anywhere, any time.

The spectrum analyzer is an ideal tool for interference measurement with its spectral display, amplitude dynamic range, and built-in measurement functions. Here is a procedure for the measurement of co-channel interference.



CO-CHANNEL INTERFERENCE

1. Set the spectrum analyzer as follows on a carrier whose modulation can be turned off:

Frequency:

Center: 55.26 MHz (center visual carrier)

Span: 50 kHz

Resolution Bandwidth: 300 kHz

Video Bandwidth: 100 kHz

Sweep time: coupled

Amplitude:

Reference Level: carrier below Reference Level

Attenuator: 0 dB provided highest level signal is below 45 dBmV

Scale: 10 dB/division

Units: dBmV

2. Set carrier at reference level and reduce the resolution bandwidth. Set a reference marker with MKR MARKER  $\Delta$ , making sure that the first marker at the highest point on the carrier signal and centered in the display.

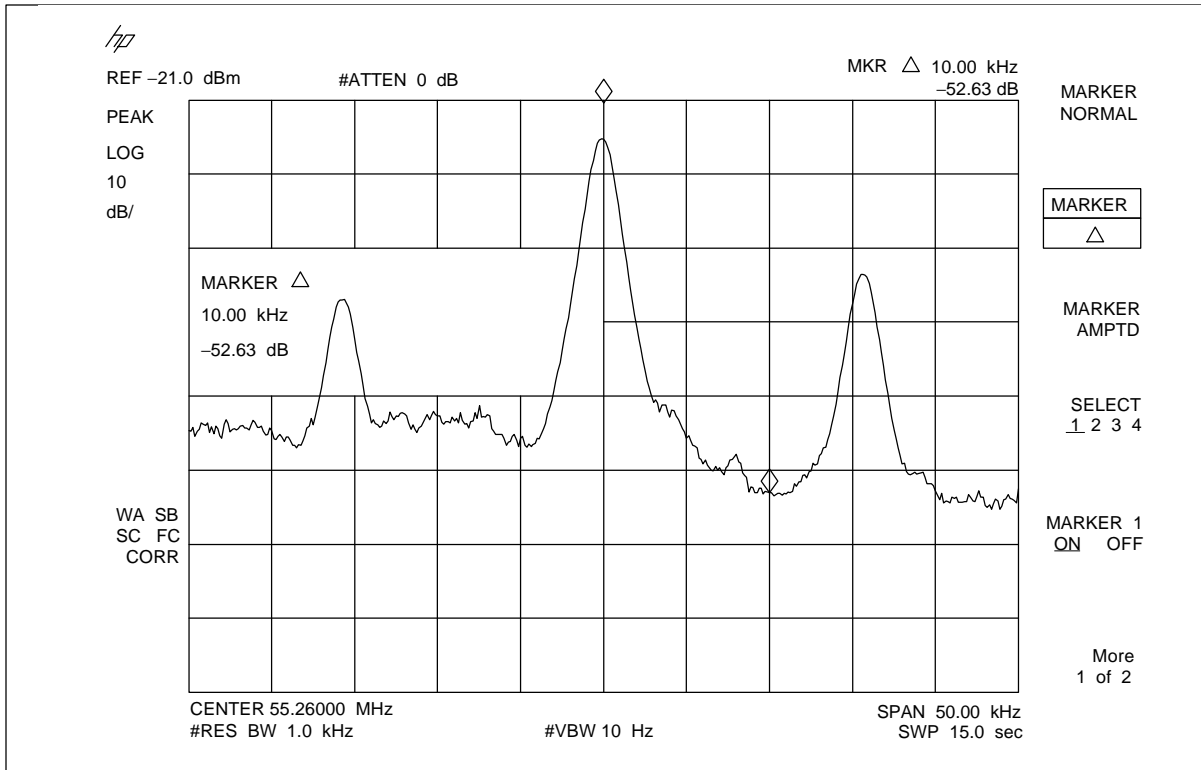
3. Resolve the sidebands with BW 1 kHz VID BW 10 Hz.

4. Remove modulation from channel.

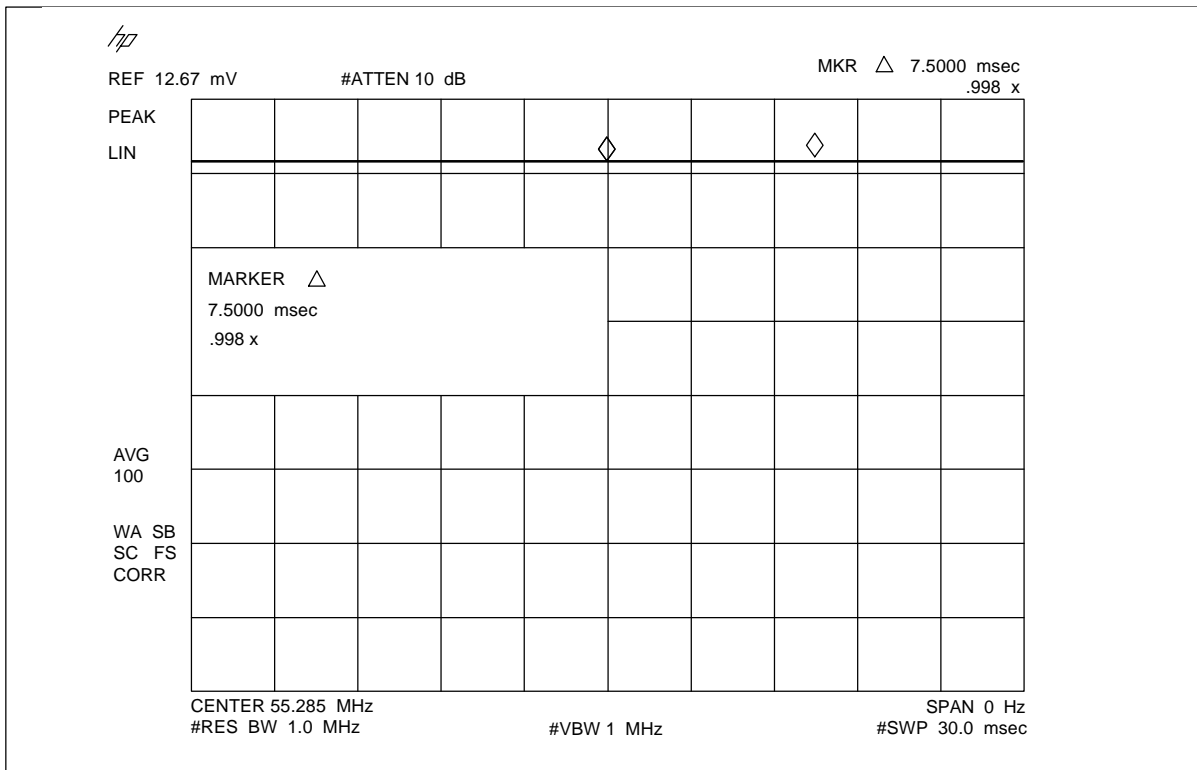
5. Use marker to measure the co-channel level relative to the carrier.

Ingress is often discovered by subscribers who will complain about TV reception problems that don't fit into one of the other interference categories. Ingress is usually signals from outside communications leaking into the cable or the subscriber's terminal. With the analyzer's optional demodulator and loudspeaker, you can often quickly determine the type of communications ingress which can lead to tracing its source.

**THERE'S NO SPECIFIC SYMPTOM FOR INGRESS**



**Figure 4.8.** Co-channel measurement on a channel that is modulated show lack of interference at 50 dB below the carrier. The "floating" reference marker was set at the carrier peak in step 2 above. With modulation off, co-channel as far down as 65 dB could be observed.



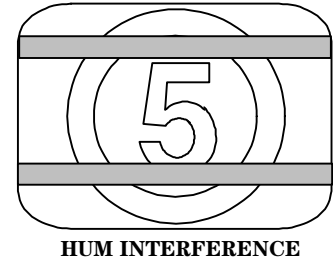
**Figure 4.9.** Measuring the amount of amplitude variation over 30 msec assures catching power line related ripples.

## Low Frequency Disturbances (Hum)

Amplitude modulation imposed upon the system's signals by the line power frequency and its harmonics. Other low frequency disturbances are much less common.

Hum is measured as the peak-to-peak amplitude modulation of the carrier compared to the carrier level. Regulation testing requires testing on an unmodulated visual carrier or pilot, but a quick measurement can be done with carrier modulation to catch out of specification performance. In other words, a quick test of the modulated carrier shows the worst results. In this test, the analyzer, with its wide resolution and video bandwidths, demodulates the carrier's amplitude modulation and displays the variation around the carrier level. The hum level is the peak to peak variation divided by the carrier level.

**LINE POWER HUM IS THE MOST COMMON**



1. Select a carrier and set the spectrum analyzer as follows:

Frequency:

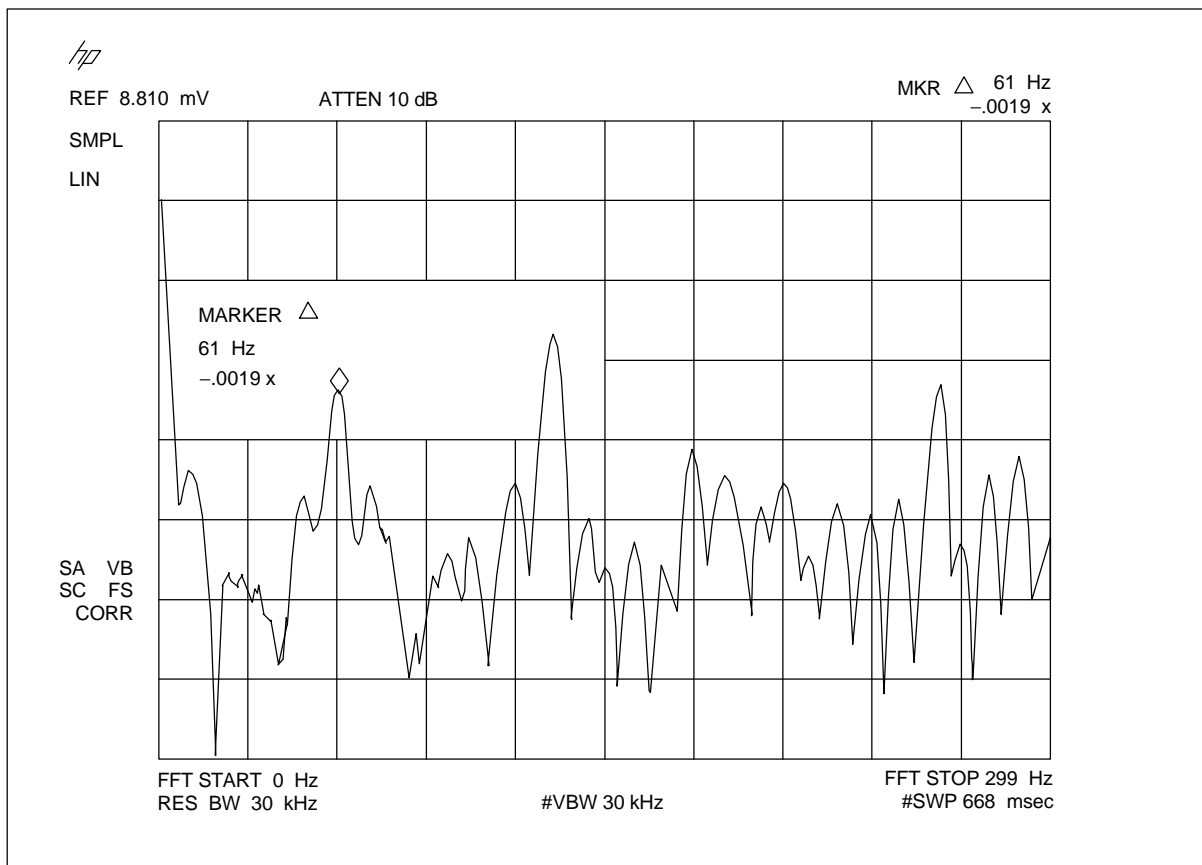
Center: 55.26 MHz (center visual carrier)

Span: 6 MHz

Resolution Bandwidth: 1 MHz

Video Bandwidth: 1 MHz

Sweep time: 30 ms



**Figure 4.10.** FFT span of the components of carrier amplitude modulation. The second harmonic is higher than the fundamental, indicating a possible ground rectification.

**HUM TEST USES THE SPECTRUM ANALYZER AS A FIXED-TUNED OSCILLOSCOPE**

Amplitude:

Reference Level: carrier below Reference Level

Attenuator: 10 dB

Scale: 10 dB/division

Units: dBmV

2. Fix-tune the spectrum analyzer with SPAN ZERO SPAN, and calibrate the display in voltage with AMPLITUDE SCALE LIN. Bring the signal to just below the top graticule using AMPLITUDE and the knob.
3. Trigger for single sweeps, each time using the marker to find the highest and lowest points on the line: SNG sweep, PEAK SEARCH MARKER Δ. Repeat this five times and record the marker ".xxx X" values in a table like Table 4.3 below.

Marker Reading	1 – reading	1 + reading
.991x	0.01	1.99
.994x	0.01	1.99
.985x	0.02	1.99
.990x	0.01	1.99
.989x	0.01	1.99
SUM =	0.05	9.95
AVERAGE =	.051/5 = .0102	9.949/5 = 1.9898
A = 1, B = reading		
Percent Hum = $2(A - B) / (A + B) = 2(1 - \text{reading}) / (1 + \text{reading})$ $= 2(.0102) / (1.9898) = 0.01025 = 1.03\%$		

**Table 4.3.** Computing hum from five successive sweeps.

4. The results of this measurement are only accurate enough to see "worst case" hum with the modulation on. If the value is below the hum allowed, have confidence that the system is operating correctly. If the hum is at or above the specification, the test needs to be repeated with the modulation off. See step 7 below.
5. The source of the hum can sometimes be predicted by the spectral content of the hum waveform. High fundamental content usually means a power supply regulation problem. High second harmonic usually indicates a power rectification at a faulty grounding. To view the hum spectrum, use the fast Fourier transform (FFT) function.

Set the spectrum analyzer as follows:

Frequency:

Center: 55.26 MHz (center visual carrier)

Span: 6 MHz

Resolution Bandwidth: coupled

Video Bandwidth: coupled

Sweep time: coupled

Amplitude:

Reference Level: carrier below Reference Level

Attenuator: 10 dB

Scale: 10 dB/division

**ONLY WORST-CASE HUM CAN BE MEASURED WITH MODULATION ON**

6. The FFT menu is under the MEAS/USER key. MEAS/USER FFT Menu MARKER→AUTO FFT and place the marker on the carrier. To continue press MARKER→AUTO FFT again. The display will show a demodulation of the carrier amplitude modulation. The span is too wide to show the power line sidebands, so change the FFT span with FFT STOP FREQ 300 Hz.
7. When possible, measure hum with the carrier modulation off. Hum levels can be accurately measured down to 0.5%. The analyzer is used as a signal level meter tuned to the carrier, and the video circuits of the analyzer simulate the view of an oscilloscope on the carrier's amplitude variations.

**MODULATION NEEDS TO BE TURNED OFF TO GIVE ACCURATE HUM RESULTS DOWN TO 0.5%**

Set up the analyzer as in step 1, except with a narrower video bandwidth and slower sweep time. BW VID BW 1 kHz and SWEEP 50 ms.

Make the measurement as in steps 6 and 7 above, omitting the averaging of readings since the carrier will be without modulation.

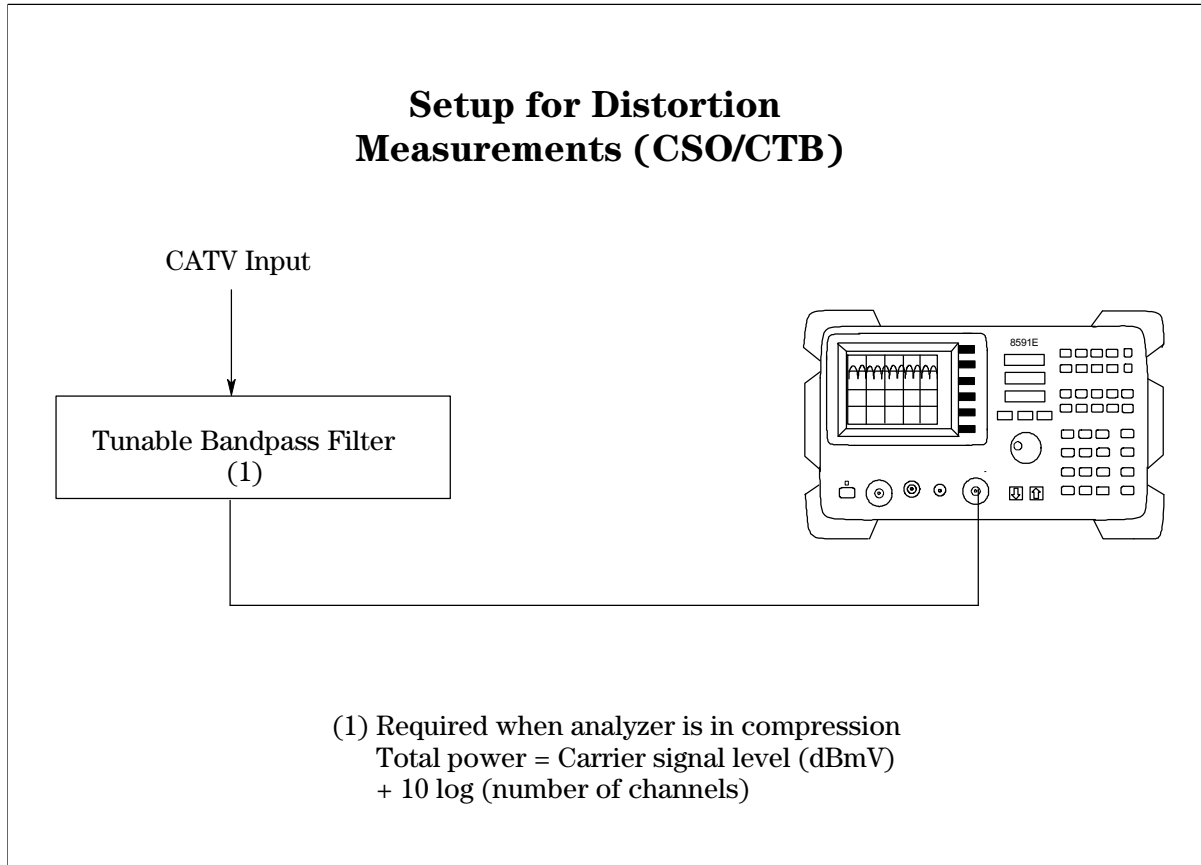
## Coherent Disturbances: Composite Second Order (CSO) and Composite Triple Beat (CTB)

Coherent disturbance measurements measure the level of unwanted sidebands which fall into the TV receiver's frequency range. These disturbances are caused by intermodulation of desired cable signals. Therefore, worst-case interference sidebands are found at known frequencies relative to the visual carrier. Only extraordinarily high levels of CSO interference can be measured with carrier modulation on, therefore, regulation testing is conducted with modulation off. Since CTB products fall at the carrier frequencies, the channel carrier must be off for CTB tests.

**IN-CHANNEL INTERFERENCE CAUSED BY CHANNEL SIGNALS ARE CALLED COHERENT**

1. Set up the analyzer as shown in Figure 4.5.
2. Set the analyzer as follows:
  - Frequency:
    - Center: 57.3 MHz (center channel)
    - Span: 6 MHz
    - Resolution Bandwidth: coupled
    - Video Bandwidth: coupled
    - Sweep time: 2 seconds
  - Amplitude:
    - Reference Level: carrier below Reference Level
    - Attenuator: 10 dB
    - Scale: 10 dB/division
3. Test for overload. Since the analyzer is a wideband receiver the power at its input mixer can cause the carrier to appear below its actual level (analyzer compression). Note the carrier level change when changing the RF attenuator. If the signal level changes by more than 0.5 dB, use the higher attenuator setting or insert a bandpass filter as shown in Figure 4.11. Because of the wide amplitude dynamic range of the spectrum analyzer, preamplification is not needed.

## Setup for Distortion Measurements (CSO/CTB)



**Figure 4.11.** CSO/CTB and cross modulation measurement setup. Following the total system power guideline, or the analyzer's quick test for overload will determine if the bandpass filter is necessary.

### CSO/CTB TESTS MUST NOT INCLUDE ANY ANALYZER OVERLOAD

4. CSO and CTB signals are measured relative to the carrier level. Place the marker peak at the reference level: BW 300 kHz VID BW 300 kHz PEAK SEARCH MKR → MARKER→RL. Place a second marker at the +1.25 MHz CSO position with MKR MARKER Δ 1.25 MHz.
5. Turn off the carrier modulation.
6. Reduce the resolution bandwidth for better dynamic range: BW 100 kHz VID BW 1 kHz. If second order distortion is not visible, reduce the resolution bandwidth to 30 kHz.
7. CSO is read as the marker amplitude: press MKR.
8. Distortion can often be identified by listening to its audio signal; it sounds like 60 Hz hum. With the marker on the distortion signal press AUX CTRL Demod DEMOD FM DEMOD ON SPEAKER ON adjust the DWELL TIME for the listening time. (If no Demod soft key appears under the AUX CTRL menu the analyzer does not have the AM/FM demodulator option 301.) Turn the carrier modulation on.
9. To measure CTB, set the analyzer as follows:
  - Frequency:
    - Center: 55.26 MHz (center channel carrier)
    - Span: 500 kHz
    - Resolution Bandwidth: 300 kHz
    - Video Bandwidth: 100 kHz
    - Sweep time: coupled

Amplitude:

Reference Level: carrier below Reference Level

Attenuator: 10 dB

Scale: 10 dB/division

10. Move carrier peak to the reference level with PEAK SEARCH MKR → MARKER → RL and set a second marker with MKR MARKER Δ.
11. Turn carrier off.
12. Increase the dynamic range of the analyzer with BW 30 kHz VID BW 30 Hz.
13. Read the CTB distortion in the MKR amplitude readout in dB. Distortion may be identified with the analyzer's demodulator as in step 8 above. Turn the carrier on.

## Crossmodulation

The procedure for measuring crossmodulation is designed to look for unwanted signals and sidebands which fall into the TV receiver response spectrum. Crossmod products, caused by horizontal sync modulation of system components, are measured as 15.75 kHz sidebands on an unmodulated carrier.

### WINDSHIELD WIPER EFFECT OF CROSSMOD

1. Set up the analyzer as shown in Figure 4.5.
2. Set the analyzer as follows:

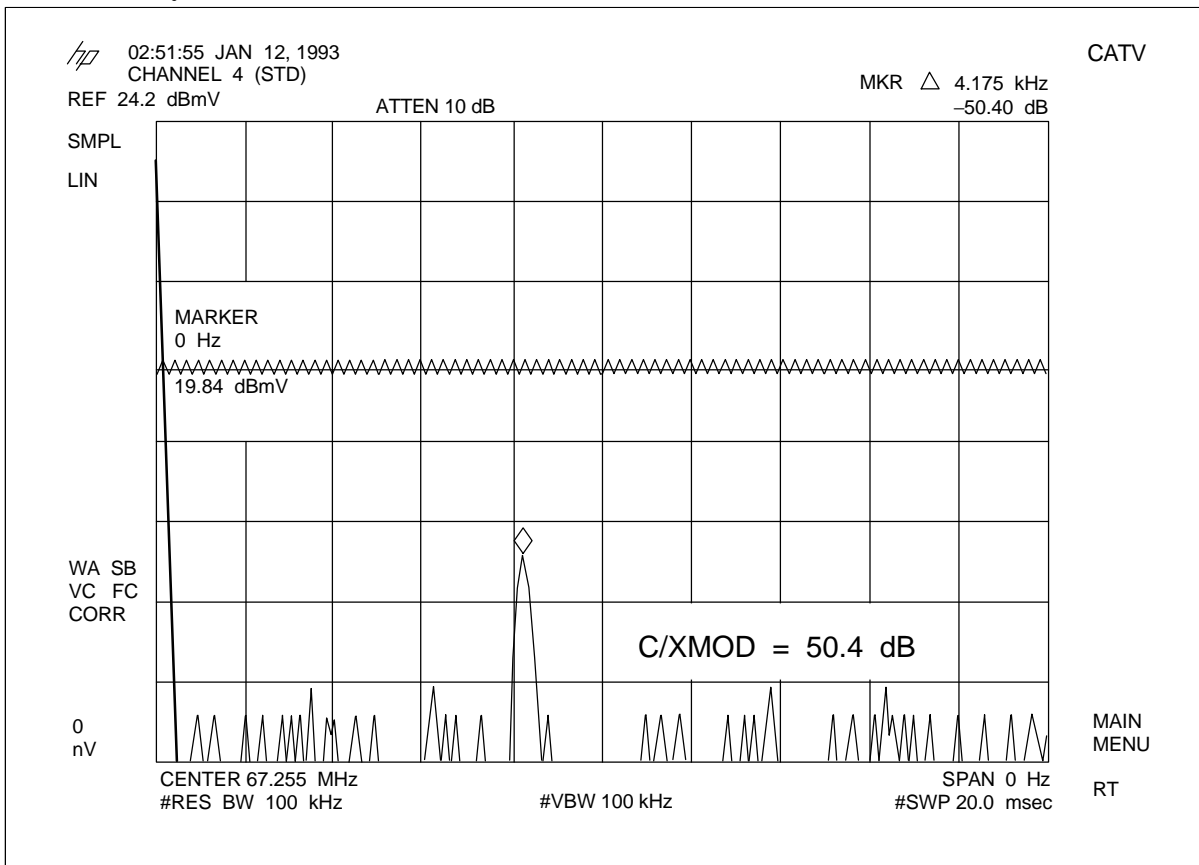
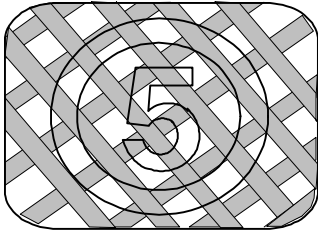


Figure 4.12. Crossmodulation.





CROSSMODULATION

**CROSSMOD  
MEASUREMENT  
REQUIRES LITTLE  
ANALYZER OVERLOAD**

Frequency:

Center: 55.26 MHz (center visual carrier)  
Span: 0 Hz  
Resolution Bandwidth: 1 MHz  
Video Bandwidth: 300 kHz  
Sweep time: 20 ms

Amplitude:

Reference Level: carrier below Reference Level  
Attenuator: 10 dB  
Scale: 10 dB/division

3. Turn the carrier modulation off.
4. Test for overload. Since the analyzer is wideband receiver the power at its input mixer can cause the carrier to appear below its actual level (analyzer compression). Note the carrier level change when changing the RF attenuator. If the signal level changes by more than 0.5 dB, use the higher attenuator setting or insert a bandpass filter as shown in Figure 4.11. Because of the wide amplitude dynamic range of the spectrum analyzer, preamplification is not needed.
5. Use the FFT function to measure the 15.8 kHz sideband. Press MEAS/USER FFT Menu MARKER→AUTO FFT and place the marker on the carrier. To continue press MARKER→AUTO FFT again. FFT STOP FREQ 30 kHz.
6. Modify the display units for dB. Press AMPLITUDE SCALE LOG PEAK SEARCH MARKER Δ. Press NEXT PEAK until the 15 kHz sideband is marked.
7. Read the cross modulation distortion as the marker amplitude in dB. Turn the carrier modulation on.

## In-Channel Frequency Response

TV channel processor flatness can be tested in two ways: with an RF signal sweep or in the vertical interval.

RF Sweep and Baseband Test Signal Method

- 1) With the processor disconnected from the cable system, set up as in Figure 4.13. For the RF input, set the sweeper to the level required by the processor. Set the start frequency to 0.5 MHz below the assigned carrier frequency and the stop frequency to 3.75 MHz above the carrier. For channel 4 at 67.26 MHz, start is 54.7 MHz and stop is 59 MHz.

- 2) Set the spectrum analyzer (for channel 4 at 67.26 MHz):

Frequency:

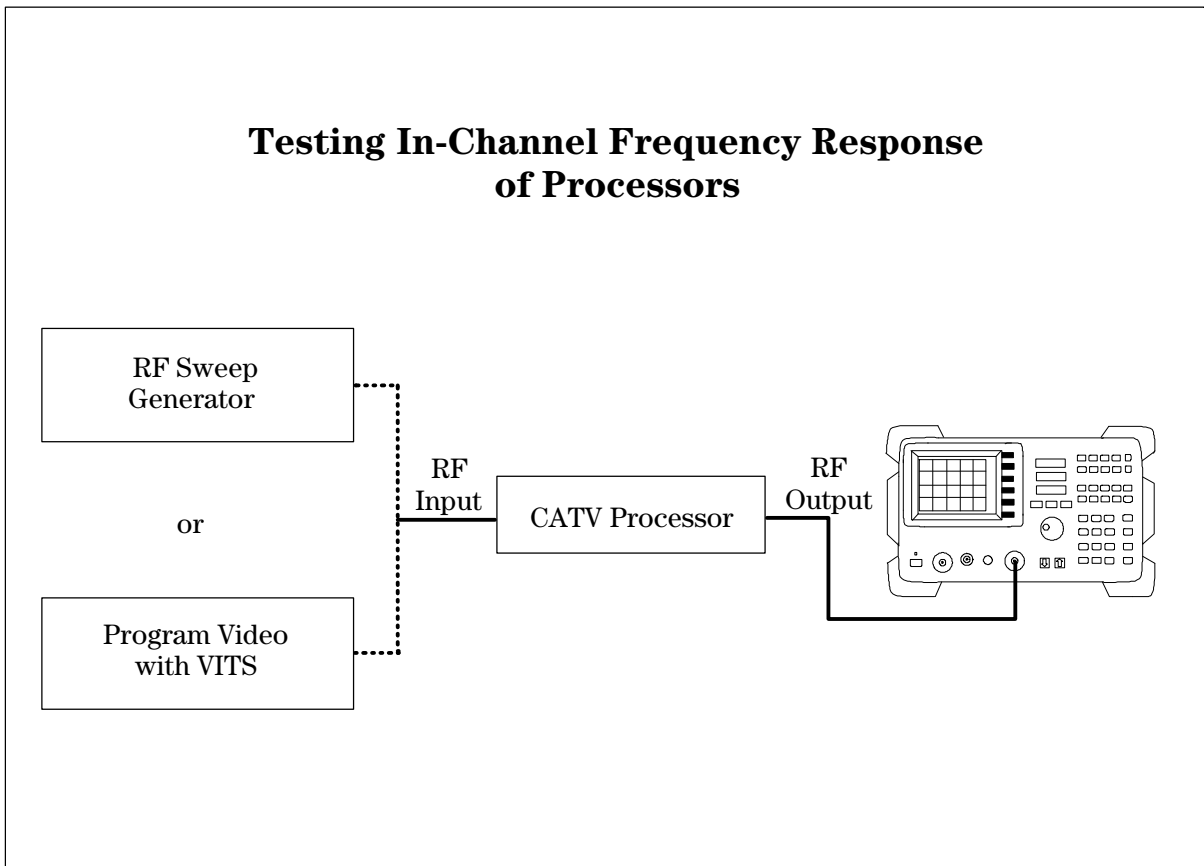
Center: 69 MHz  
Span: 6 MHz  
Resolution Bandwidth: 300 kHz  
Video Bandwidth: 300 kHz  
Sweep time: coupled

Amplitude:

Reference Level: highest signal below Reference Level by 5 to 10 dB  
Attenuator: 0 dB provided highest level signal is below 45 dBmV

**IN-CHANNEL FREQUENCY  
RESPONSE WITH VIDEO  
TEST SIGNAL OR  
SWEEP GENERATOR IS  
ACCURATE BUT OFF-LINE**

## Testing In-Channel Frequency Response of Processors



**Figure 4.13.** Testing in-channel frequency response with direct RF sweep across the channel band or a baseband video signal.

Scale: 10 dB/division

Units: dBmV

- 3) Since the sweeper's sweep rate is not the same as the analyzer's sweep rate, the analyzer needs time to accumulate amplitude data in the display. Press TRACE MAX HOLD A SWEEP 750 ms and wait until the line swept is smooth. See Figure 4.14 for the RF input results.
- 4) Measure the highest and lowest points within the specified frequency range. Press PEAK SEARCH MARKER Δ and use the knob to find the lowest value within the frequency range.
- 5) Flatness is the marker amplitude divided by 2.

Baseband video can be input directly to the processor:

- 1) Use the setup of Figure 4.13. For the easiest to interpret signal response, select  $\sin x/x$  test signal on the video signal generator.
- 2) Setup the analyzer as follows for channel 4:
  - Frequency:
    - Center: 69 MHz
    - Span: 6 MHz
    - Resolution Bandwidth: 300 kHz
    - Video Bandwidth: 300 kHz
    - Sweep time: coupled

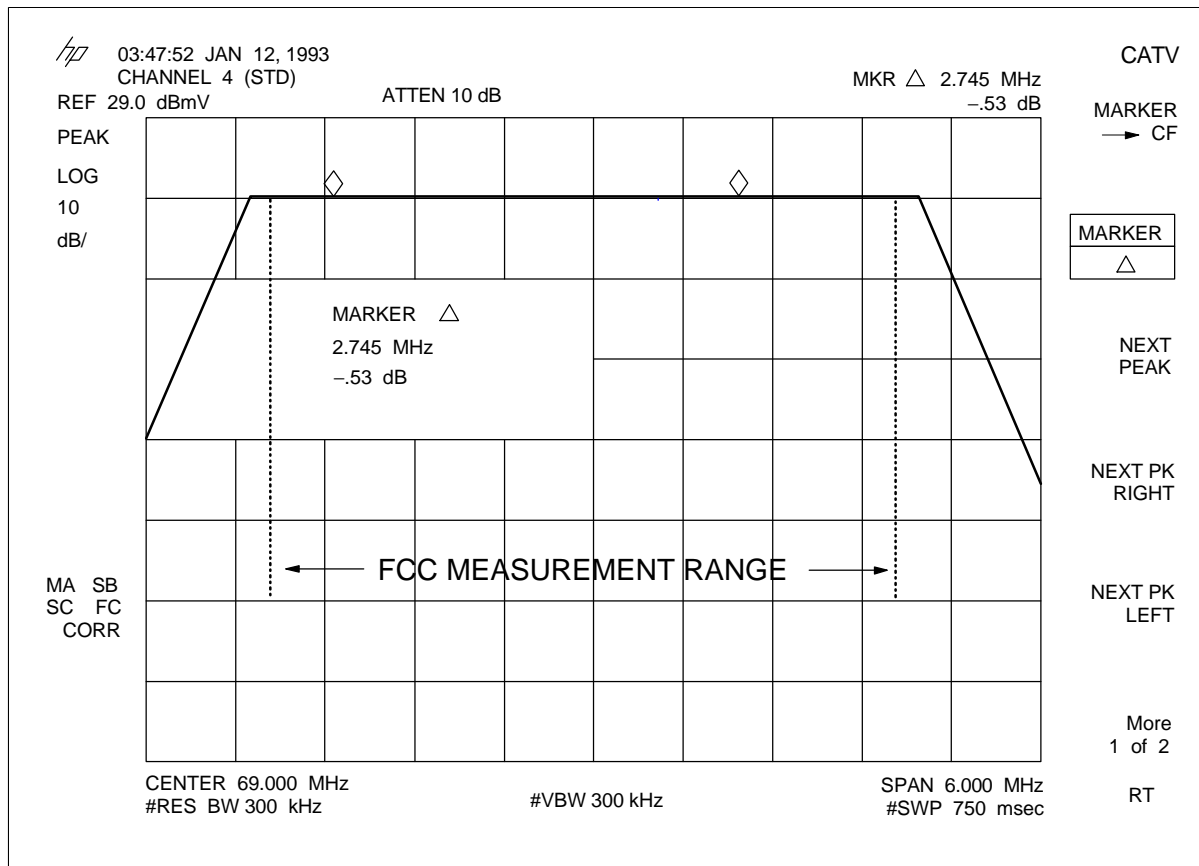


Figure 4.14. Measuring channel frequency response with an RF sweeper and spectrum analyzer.

Amplitude:

Reference Level: highest signal below Reference Level by 5 to 10 dB

Attenuator: 0 dB provided highest level signal is below 45 dBmV

Scale: 10 dB/division

Units: dBmV

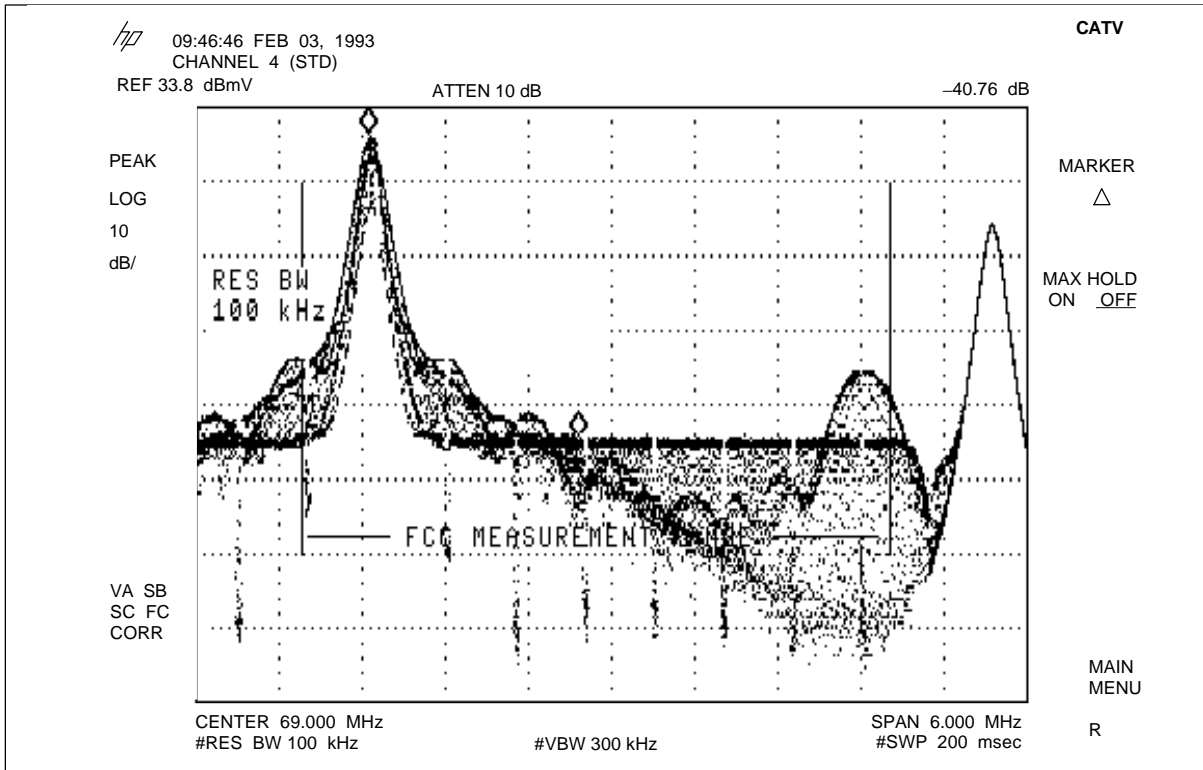
- 3) Use the Analog+ display to view the mean value of the video signal. This mean value represents the flatness of the channel. Press DISPLAY Analog+ ON.
- 4) Use the markers to measure the largest amplitude differential along the flat frequency response, ignoring the carrier response. Press MKR and move to the maximum with the knob, press MARKER Δ and move to the lowest response.
- 5) The processor flatness is the marker Δ divided by 2.  
If another type of video signal is used, such as full-field or multiburst, the procedure would use a normal display. Change the sweep time to 750 msec and trace to MAX HOLD as before.

## Using Program Video and VITS

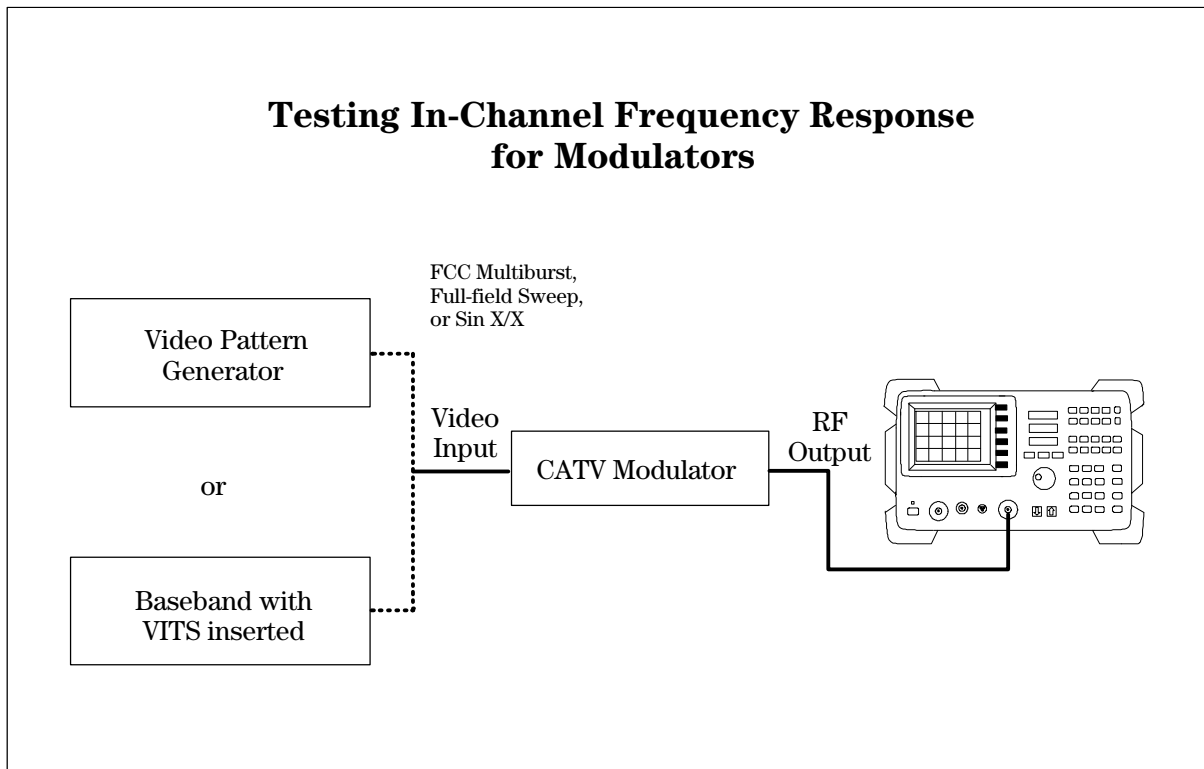
### ON-LINE MEASUREMENTS:

- PROGRAM VIDEO
- PROGRAM VITS

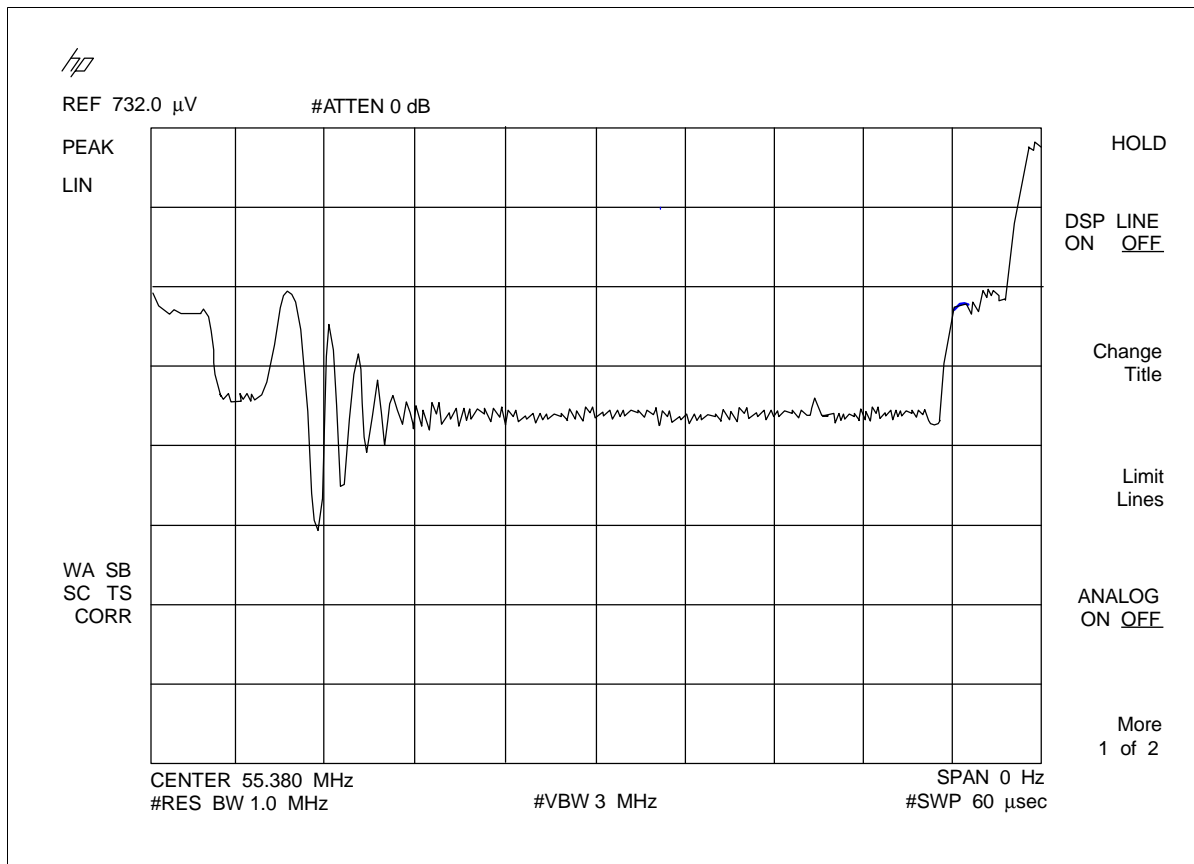
To avoid interrupting program video the in-channel frequency response can be made with a vertical interval test signal or VITS. The VITS can



**Figure 4.15.** A  $\sin x/x$  video test signal is applied to the CATV modulator and the analyzer displays the collective results.



**Figure 4.16.** Testing in-channel frequency response with program video using local VITS or inserted VITS on program video.



**Figure 4.17.** A full line sweep VITS is on line 16 of channel 2. The HP 8591E options for fast sweep and TV sync trigger enable the analyzer to view this signal. The measurement process does not require these options, however.

originate with the program video or can be injected in front of the processor. Figure 4.16 shows the setups.

## USE PROGRAM VITS FOR NON-INTERFERING MEASUREMENTS

- 1) Set up as in Figure 4.16. The channel selected should be one which has a VITS signal. Figure 4.15 shows the VITS signal for this test. Set the spectrum analyzer as follows:

Frequency:

Center: 57.3 MHz

Span: 6 MHz

Resolution Bandwidth: 300 kHz

Video Bandwidth: 300 kHz

Sweep time: coupled

Amplitude:

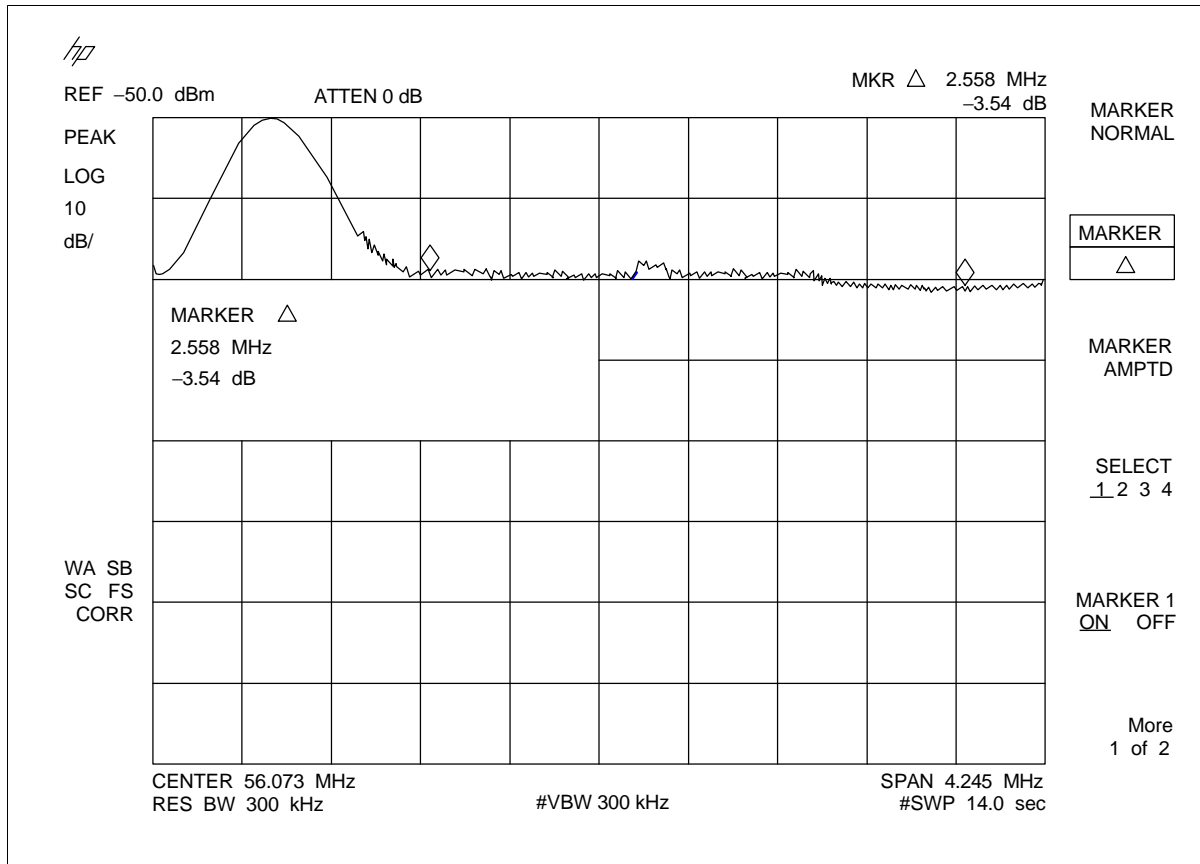
Reference Level: highest signal below Reference Level by 5 to 10 dB

Attenuator: 0 dB provided highest level signal is below 45 dBmV

Scale: 10 dB/division

Units: dBmV

- 2) Set the start and stop frequencies to the start and stop frequencies. Press **PEAK SEARCH** MARKER  $\Delta$  -5 MHz MARKER  $\Delta$  4.25 MHz to mark the measurement boundaries. Press **MARKER**  $\rightarrow$  MARKER  $\Delta$  SPAN to set the start and stop frequencies to the measurement boundaries.



**Figure 4.18.** The in-channel frequency response of using a full line VITS signal.

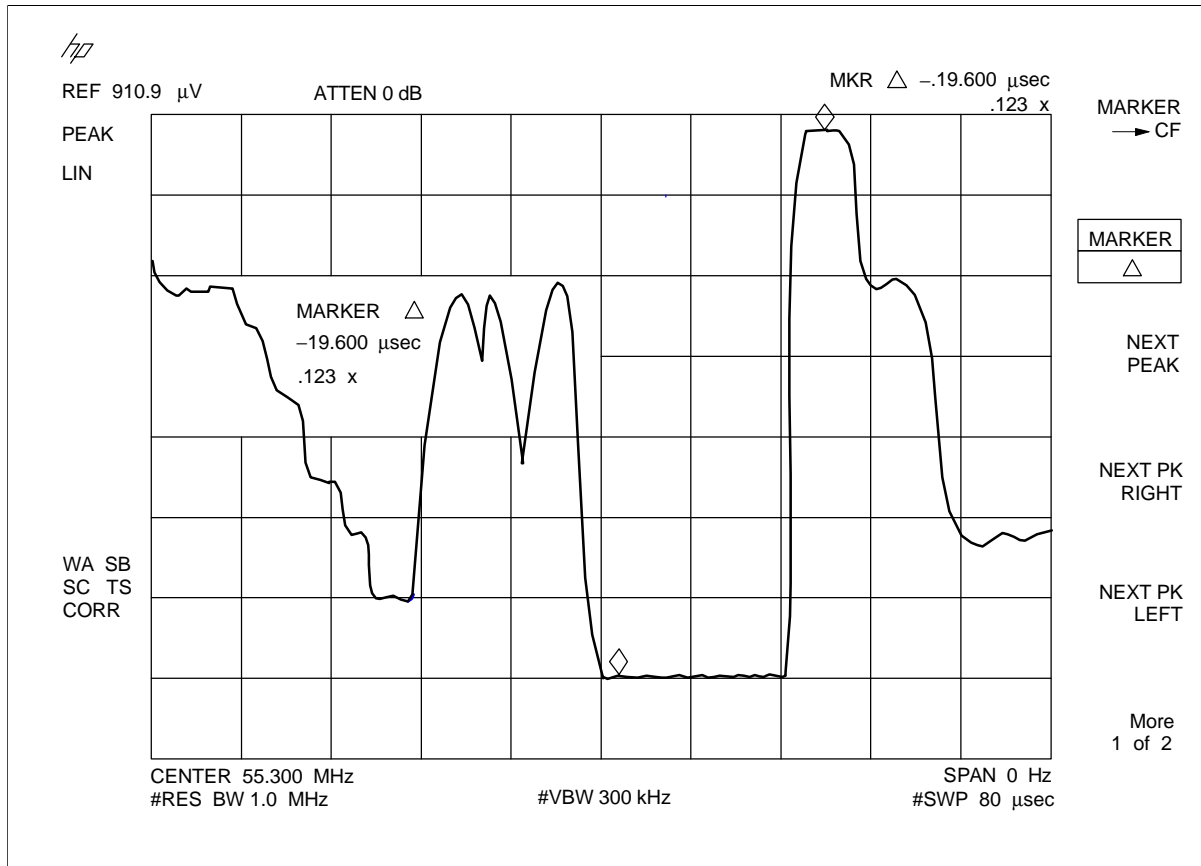
- 3) Slow the sweep time down to capture at least one VITS response per frequency point. There are 401 frequency points and the VITS occurs at a 30 Hz rate with interleave. The sweep time needs to be longer than  $1/30 \text{ seconds} \times 401 \text{ points} = \text{approximately } 14 \text{ seconds}$ .
- 4) Measure the widest amplitude variation, excluding the carrier amplitude. Press MKR MARKER NORMAL and move the marker to the highest response point. Press MARKER Δ and move to the lowest response point.
- 5) The peak to peak in-channel response value is the MARKER Δ amplitude divided by 2, or  $3.54 \text{ dB}/2 = \pm 1.77 \text{ dB}$ .

## Depth of Modulation

Accurate and repeatable measurement of depth of modulation requires a video test signal. However, rough measurements may be made on program material. The following procedure shows both tests.

### DEPTH OF MODULATION WITH VITS

1. Set the spectrum analyzer on a carrier with a VITS:  
 Frequency:  
     Center: 55 MHz (center visual carrier)  
     Span: 6 MHz  
     Resolution Bandwidth: 1 MHz



**Figure 4.19.** The depth of modulation for channel 2 on line 18 VITS shows a depth just out of specification.

Video Bandwidth: 300 kHz

Sweep time: coupled

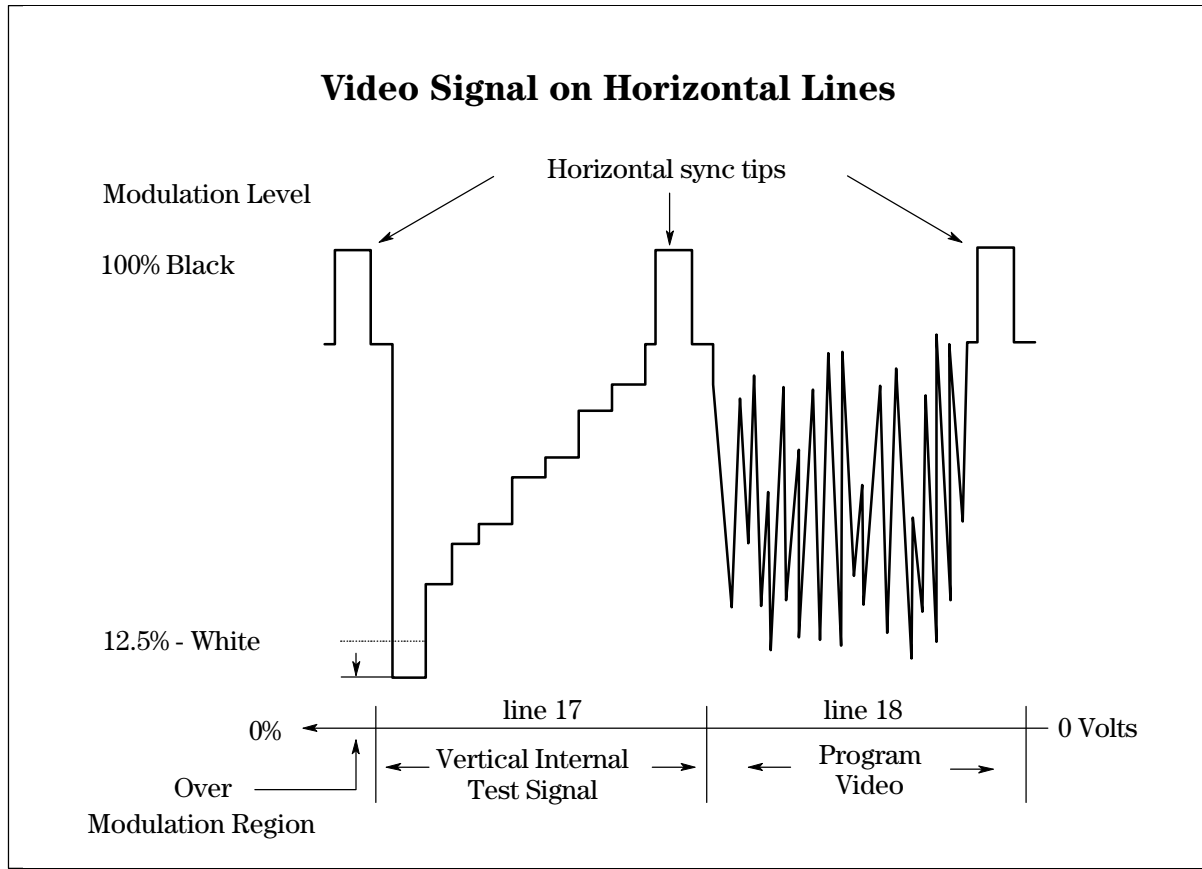
Amplitude:

Reference Level: carrier below Reference Level

Attenuator: 0 dB provided highest level signal is below 45 dBmV

2. Center the signal with PEAK SEARCH MARKER→CF
3. Make the spectrum analyzer a voltage tuned receiver by reducing the span to zero and setting the scale to linear, or voltage: press SPAN ZERO AMPLITUDE SCALE LIN.
4. Reduce the sweeptime to 80 μsec in order to view the individual VITS line. Press SWEEP 80 μsec, TRIG TV TRIGGER. At the prompt "TV LINE #" select the VITS line, 18 Hz (ENTER). Use single sweep mode to keep the screen data stable with SNGL.
5. The depth of modulation measured with the Δ marker. Press PEAK SEARCH MARKER Δ. The marker amplitude readout is the percent from zero volts, the bottom graticule, to the top horizontal sync marker. In this case .123 or 12.3%.
6. The depth of modulation is the difference from 100%, or 87.7%. This measurement should be repeated several time to confirm the maximum modulation depth.

When no VITS is available, program material may be used to estimate the depth of modulation. Repeat steps 1 through 3 above.



**Figure 4.20.** The depth of modulation for channel 2 on when no VITS is available.

4. Change the sweeptime to 20 ms in order to view one or more horizontal sweep periods. Press SWEEP 20 ms, TRIG FREE RUN. Use single sweep mode to keep the screen data stable with SNGL.
5. Press SNGL until the distance between the tip of the sync pulse and the lowest response is farthest apart. The depth of modulation measured with the marker. Press PEAK SEARCH MARKER Δ. The marker amplitude readout is the percent from zero volts, the bottom graticule, to the top horizontal sync marker. In this case .183 or 18.3%.
6. The depth of modulation is the difference from 100%, or 81.7%. This measurement is not repeatable since it relies on program material to provide a maximum depth response. This technique is sufficient to show out-of-spec performance, however.

**DEPTH OF MODULATION PERFORMED ON PROGRAM VIDEO WITHOUT VITS MEASURE APPARENT PROGRAM LEVEL (APL)**

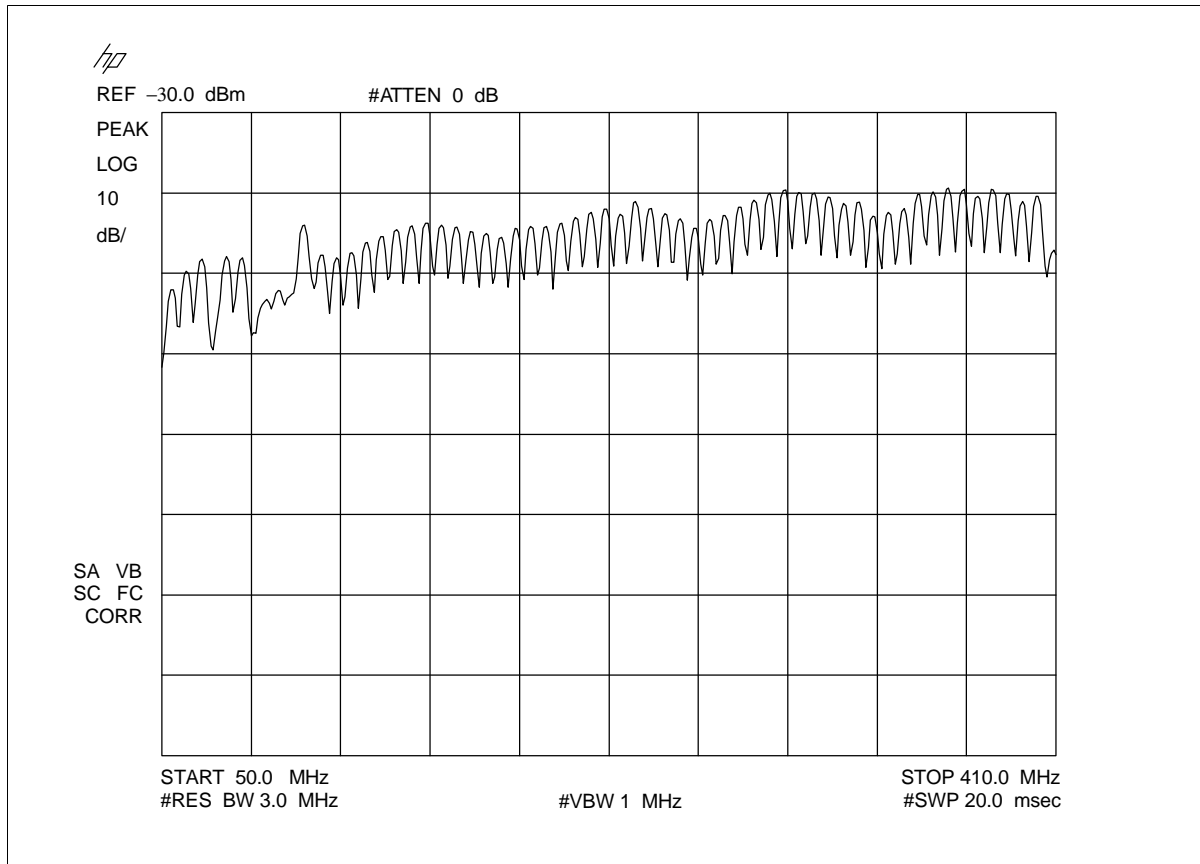
**...SUFFICIENT TO SEE POOR PERFORMANCE**

## System Frequency Response

The non-interfering frequency response measurement with a spectrum analyzer is done in a two-step process. First, a reference trace is obtained and stored during the frequency response setup. Second, the system frequency response is measured by comparing the reference trace to the spectrum measured at another point in the system.

**A SPECTRUM ANALYZER WITH NORMALIZATION MEMORY MAKES NON-INTERFERING SYSTEM FLATNESS TEST**





**Figure 4.21.** Reference trace of entire system for the system frequency response test.

Reference and test signal levels should be at similar levels and with the same amount of tilt or slope for true system flatness to be measured. System flatness can be used to adjust gain and slope if reference and test points are selected carefully.

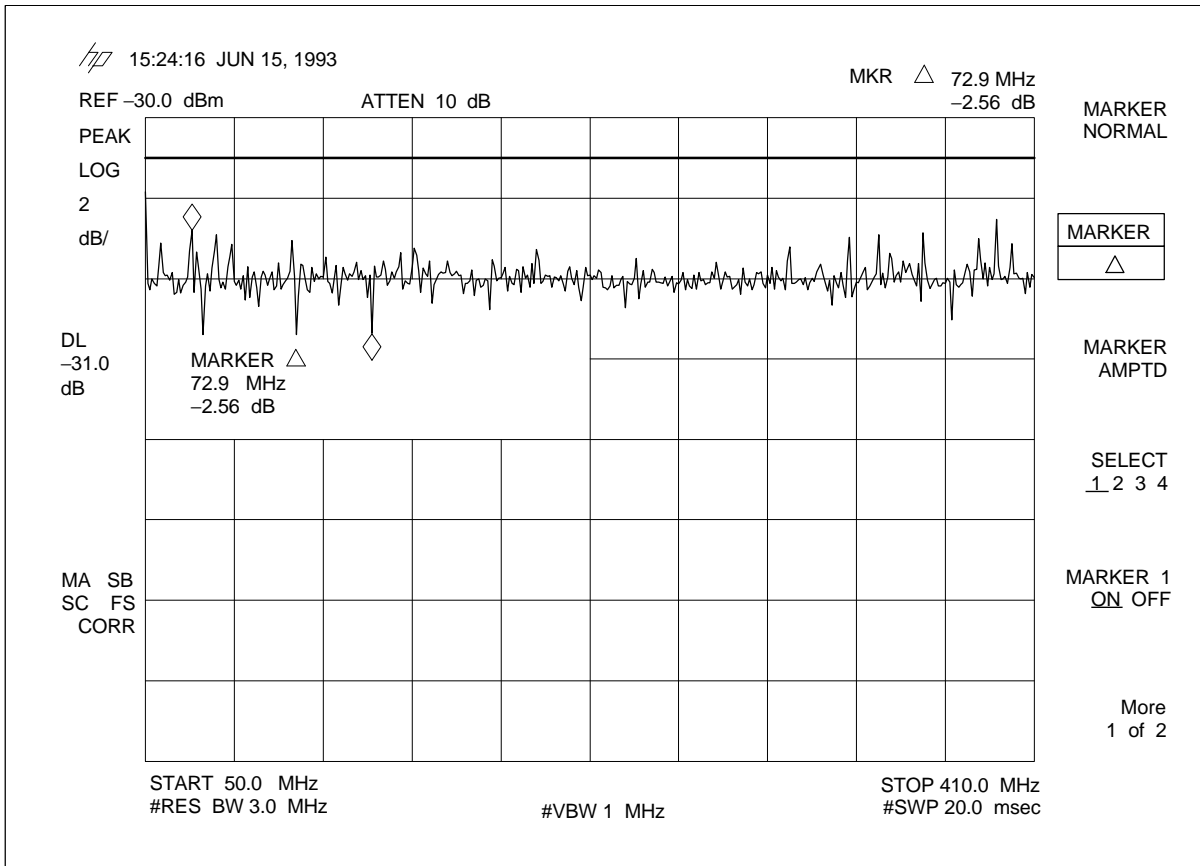
This procedure relies on the storage of spectral data to make comparisons. Hewlett-Packard spectrum analyzers have built-in memory as well as memory cards for storing and recalling trace information. The following procedure assumes the use of a memory card.

To save the reference spectrum:

- 1) This measurement potentially compares signals over a wide span and over a wide variety of temperatures. It is important to perform frequency calibration in the spectrum analyzer according to the user's guide whenever a reference or field test is run.
- 2) After PRESET, set the analyzer as follows, using the frequency range or ranges for test at the test points:

Frequency:

Start: 50 MHz  
 Stop: 410 MHz  
 Resolution Bandwidth: coupled  
 Video Bandwidth: coupled  
 Sweep time: coupled



**Figure 4.22.** System flatness measured by subtracting the reference and input traces. This ripple effect is probably due to a system mismatch.

**Amplitude:**

Reference Level: highest signal below Reference Level by 5 to 10 dB

Attenuator: 0 dB provided highest level signal is below 45 dBmV

Scale: 10 dB/division

Units: dBmV

- 3) Allow the maximum of each channel to "fill in" with TRACE TRACE A MAX HOLD. See Figure 4.21.
- 4) Insert a memory card in the slot just below the display and SAVE CARD Trace→Card TRACE A. The display asks what register you want to save. Press 1 ENTER (Hz).
- 5) To confirm the trace is saved press RECALL Card Catalog CATALOG TRACES and check the date and time stamp on the entry for trace #1. Exit the catalog with Exit Catalog.
- 6) Remove the card for use in field measurements on the same or other spectrum analyzers.

To make a system frequency response measurement:

- 1) Frequency calibrate the spectrum analyzer.
- 2) Insert the memory card and recall the reference trace with PRESET RECALL CARD Catalog Card CATALOG TRACES and highlight the reference trace saved in the above procedure. Press LOAD FILE. The reference trace will be automatically loaded into Trace B in the view

**SYSTEM FLATNESS  
STEPS:**

- 1. TAKE REFERENCE  
TRACES AT THE  
HEADEND**
- 2. COMPOSE SYSTEM  
RESPONSE AT  
REQUIRED TEST**

mode. The recall also resets the analyzer state to the same start and stop frequencies.

- 3) Write the test trace into A with TRACE Clear Write A MAX HOLD and after the trace "fills in" press VIEW A. Blank B with TRACE B BLANK B.
- 4) Compare the traces A and B with TRACE More 2 of 3 NORMALIZE ON and set the differential to the center of the display with NORMALIZE POSITION with the control knob.
- 5) Improve the amplitude resolution of the traces with AMPLITUDE SCALE LOG 2 dB.
- 6) Use the markers to determine the largest variation, PEAK SEARCH MARKER Δ.





# Appendix A

## Reference Tables

**Table A.1.**

		TO dBmV in impedance, $Z_2$				
		$50\Omega$	$75\Omega$	$300\Omega$	$600\Omega$	$Z_2$
<b>FROM dBmV in <math>Z_1</math></b>	<b><math>50\Omega</math></b>	0	+1.76 dB	+7.78 dB	+10.79 dB	$+10\log_{10}\frac{Z_2}{50}$
	<b><math>75\Omega</math></b>	-1.76 dB	0	+6.02 dB	+9.03 dB	$+10\log_{10}\frac{Z_2}{75}$
	<b><math>300\Omega</math></b>	-7.78 dB	-6.02 dB	0	+3.01 dB	$+10\log_{10}\frac{Z_2}{300}$
	<b><math>600\Omega</math></b>	-10.79 dB	-9.03 dB	-3.01 dB	0	$+10\log_{10}\frac{Z_2}{600}$
	<b><math>Z_1</math></b>	$+10\log_{10}\frac{50}{Z_1}$	$+10\log_{10}\frac{75}{Z_1}$	$+10\log_{10}\frac{300}{Z_1}$	$+10\log_{10}\frac{600}{Z_1}$	$+10\log_{10}\frac{Z_2}{Z_1}$

Where Z = the impedance of the system

Common conversion factors:  
 1 milliwatt ( $10^{-3}$  watts) in  $75\Omega$  = 0 dBm = 48.75 dBmV  
 0 dBm = +107 dB $\mu$ V in  $50\Omega$   
 0 dBmV = +60 dB $\mu$ V  
 0 dBmV ( $50\Omega$ ) = + 1.76 dBmV ( $75\Omega$ ), See Table 2.1

**Table A.1.** dBmV impedance conversion. For the same power level adjust the dBmV reading for different cable and circuit impedances by the numbers in the boxes. For example, to convert 42 dBmV ( $50\Omega$ ) to  $75\Omega$ , add 1.76 db to give 43.76 dBmV ( $75\Omega$ ). Insertion loss of impedance matching transformer is not included.

**Table A.2.a.**

		TO		
		Volts, V	Watts, P	dBm
	<b>Volts, V</b>	$V$	$\frac{V^2}{Z}$	$10 \log \frac{V^2}{10^{-3} * Z}$
	<b>Watts, P</b>	$\sqrt{P * X}$	$\sqrt{P * Z}$	$10 \log \frac{P}{10^{-3}}$
	<b>dBm</b>	$\sqrt{\log^{-1}\left[\frac{dBm}{10}\right] * Z * 10^{-3}}$	$\log^{-1}\left[\frac{dBm}{10}\right] * Z * 10^{-3}$	<i>dBm</i>
	<b>dBmV</b>	$\log^{-1}\left[\frac{dBmV}{20} - 3\right]$	$\frac{1}{Z} \log^{-1}\left[\frac{dBmV}{10} - 6\right]$	<i>dBmV</i> + 30 - 10log Z
	<b>dBμV</b>	$\log^{-1}\left[\frac{dBμV}{20} - 6\right]$	$\frac{1}{Z} \log^{-1}\left[\frac{dBμV}{10} - 12\right]$	<i>dBμV</i> + 90 - 10log Z

Where Z = the impedance of the system

Common conversion factors:  
 1 milliwatt ( $10^{-3}$  watts) in  $75\Omega = 0 \text{ dBm} = 48.75 \text{ dBmV}$   
 0 dBm = +107 dBμV in  $50\Omega$   
 0 dBmV = +60 dBμV  
 0 dBmV ( $50\Omega$ ) = + 1.76 dBmV ( $75\Omega$ ), See Table 2.1

**Table A.2.a.** Conversion formula for all the common units of signal level measurement. Find the current units in the left column, then use the corresponding formula under the "To" units column. Example: Convert +10 dBm to dBmV in  $75\Omega$ . Substitute into the formula " $\text{dBm} + 30 + 20 \log \sqrt{Z}$ ",  $10 \text{ dBm} = + 10 + 30 + 20 \log \sqrt{75} = 40 + 18.75 = 58.75 \text{ dBmV} (75\Omega)$ . To convert this figure into  $50\Omega$  we would refer to the left column of Table 2.1 to find the  $75\Omega$  row, and find the conversion factor under the desired  $50\Omega$ ,  $-1.76 \text{ dB}$  to give  $58.75 \text{ dBmV} (75\Omega) = 58.75 - 1.75 = 57.0 \text{ dBmV} (50\Omega)$ . Note that mismatch and insertion losses are not included in these conversions.

**Table A.2.b.**

		TO		
		<b>dBmV</b>	<b>dB<math>\mu</math>V</b>	
	<b>Volts, V</b>	$20 \log \frac{V}{10^{-3}}$	$20 \log \frac{V}{10^{-6}}$	
	<b>Watts, P</b>	$20 \log \left[ \frac{\sqrt{Z * P}}{10^{-3}} \right]$	$20 \log \left[ \frac{\sqrt{Z * P}}{10^{-6}} \right]$	
	<b>dBm</b>	$dBm + 30 + 10 \log Z$	$dBm + 60 + 10 \log Z$	
	<b>dBmV</b>	$dBmV$	$dBmV + 60$	
	<b>dB<math>\mu</math>V</b>	$dB\mu V - 60$	$dB\mu V$	
Where Z = the impedance of the system				
Common conversion factors:				
1 milliwatt ( $10^{-3}$ watts) in $75\Omega = 0 \text{ dBm} = 48.75 \text{ dBmV}$				
0 dBm = +107 dB $\mu$ V in $50\Omega$				
0 dBmV = +60 dB $\mu$ V				
0 dBmV ( $50\Omega$ ) = + 1.76 dBmV ( $75\Omega$ ), See Table 2.1				

**Table A.2.b.** Conversion formula for all the common units of signal level measurement. Find the current units in the left column, then use the corresponding formula under the "To" units column. Example: Convert +10 dBm to dBmV in  $75\Omega$ . Substitute into the formula "dBm + 30 + 20 log  $\sqrt{Z}$ ",  $10 \text{ dBm} = + 10 + 30 + 20 \log \sqrt{75} = 40 + 18.75 = 58.75 \text{ dBmV} (75\Omega)$ . To convert this figure into  $50\Omega$  we would refer to the left column of Table 2.1 to find the  $75\Omega$  row, and find the conversion factor under the desired  $50\Omega$ ,  $-1.76 \text{ dB}$  to give  $58.75 \text{ dBmV} (75\Omega) = 58.75 - 1.75 = 57.0 \text{ dBmV} (50\Omega)$ . Note that mismatch and insertion losses are not included in these conversions.



**Table A.3.**

System Signals		Possible $f_1 \pm f_2 \pm f_3$ Products Falling Within:			
Channel	Mhz	53 Mhz	to 88 Mhz	174 Mhz	to 186 Mhz
2	55.25	53.25	71.00	175.00	195.25
3	61.25	55.00	71.25	176.25	195.50
4	67.25	55.50	73.25	177.25	197.00
5	77.25	57.25	77.00	177.50	197.25
6	83.25	57.50	79.25	179.00	199.00
7	175.25	59.00	79.50	181.00	199.50
8	181.25	59.25	79.75	181.50	201.25
9	187.25	61.00	81.00	183.25	201.50
10	193.25	61.50	82.25	183.50	203.00
11	199.25	62.50	83.50	185.00	203.25
12	205.25	63.75	85.25	185.25	205.00
13	211.25	65.00	85.50	187.00	205.50
Pilot I	73.50	65.25	85.75	187.50	207.50
Pilot II	118.25	67.50	87.00	189.25	209.00
		69.75	87.25	189.50	209.25
				191.00	210.25
				191.25	211.25
				193.00	211.50
				193.50	

**Table A.3.** Triple beat intermod product example.

# Appendix B

## Glossary

- active marker** In spectrum analyzer operation, the marker on a trace that can be repositioned by front-panel controls or programming commands.
- active trace** In spectrum analyzer operation, the trace (commonly A, B, or C) that is being swept (updated) with incoming signal information.
- adapter** Mechanism for attaching parts, especially those parts having different physical dimensions or electrical connectors.
- ambient temperature** The temperature surrounding apparatus and equipment. Synonymous with room temperature.
- amplifier** Device used to increase the operating level of an input signal. Used in a cable system's distribution plant to compensate for the effects of attenuation caused by coaxial cable and passive device losses.
- amplitude** The size or magnitude of a voltage or current waveform; the strength of a signal.
- amplitude accuracy** In spectrum analyzer operation, the general uncertainty of a spectrum analyzer amplitude measurement, whether relative or absolute.
- amplitude modulation (AM)** The form of modulation in which the amplitude of the signal is varied in accordance with the instantaneous value of the modulating signal. Measured as percent: the ratio of half the difference between the maximum and minimum amplitudes of an amplitude modulated wave to the average amplitude expressed in percentage.
- analog** A display scale for signal amplitudes calibrated in dB per division.
- bandpass filter** A device which allows signal passage to frequencies within its design range and which effectively bars passage to all signals outside that frequency range.
- bandwidth selectivity** A measure of the spectrum analyzer's ability to resolve signals unequal in amplitude. It is the ratio of the 60 dB bandwidth to the 3 dB bandwidth for a given resolution filter (IF). Bandwidth selectivity tells us how steep the filter skirts are. Bandwidth selectivity is sometimes called shape factor.
- center frequency** The frequency represented on the display as the center graticule.
- coaxial** Cable and connectors used for the transmission of broadband data. Synonymous with coax.
- command** In spectrum analyzer operation, a set of instructions that are translated into instrument actions. The actions are usually made up of individual steps that together can execute an operation. Generally, for spectrum analyzers it is a sequence of code that controls some operation of a spectrum analyzer. These codes can be keyed in via a controller, or computer. Refer also to **function**.
- compression** See gain compression.
- continuous sweep mode** The spectrum analyzer condition where traces are automatically updated each time trigger conditions are met.
- dB** See Decibel.
- dBc** Decibel carrier. A ratio expressed in decibels that refers to the gain or loss relative to a reference carrier level.
- dBd** Decibel-dipole. A ratio expressed in decibels that refers to the gain or loss relative to a dipole antenna.
- dBmV** See Decibel millivolt.
- Decibel (dB)** A unit that expresses the ratio of two power levels on a logarithmic scale.
- Decibel microvolt (Db $\mu$ V)** A unit of measurement referenced to one microvolt across a specified impedance.
- Decibel millivolt (dBmV)** A unit of measurement referenced to one millivolt across a specified impedance (75 ohms in CATV). Spectrum analyzer units are selected.

- Decibel milliwatt (dBm)** A unit of measurement referenced to one milliwatt across a specified impedance. dBm is the default unit of power in a spectrum analyzer.
- delta marker** A spectrum analyzer mode in which a fixed reference marker is established, then a second active marker becomes available so it can be placed anywhere along the trace. A readout indicates the relative frequency separation and amplitude difference between the reference and active markers.
- demodulate** The capability of the analyzer to retrieve an information carrying signal from a modulated carrier. A loudspeaker and audio jack is provided for listening to signals for purposes of identification (or entertainment).
- demodulator** A built in circuit, usually optional, that allows viewing and/or listening to the modulation of a carrier signal.
- display dynamic range** The maximum dynamic range over which both the larger and smaller signal can be viewed simultaneously on the display. For spectrum analyzers with a maximum logarithmic display of 10 dB/division, the actual dynamic range may be greater than the display dynamic range. Refer also to **dynamic range**.
- display fidelity** The measurement uncertainty of relative differences in amplitude. With digital displays, markers are used to measure the signal. As a result, measurement differences are stored in memory, and the ambiguity of the display is eliminated from the measurement.
- distortion** An undesired change in waveform of a signal in the course of its passage through the spectrum analyzer's circuits.
- drift** The specified amount of frequency reference change allowed. See frequency stability.
- dynamic range** The power ratio (dB) between the smallest and largest signals simultaneously present at the input of a spectrum analyzer that can be measured with some degree of accuracy. Dynamic range generally refers to measurement of distortion or intermodulation products.
- electromagnetic interference (EMI)** Any electromagnetic energy, natural or manmade, which may adversely affect performance of the system.
- fast Fourier transform (FFT)** A mathematical operation performed on the time-domain signal of the analyzer's video IF circuits to yield the individual spectral components that constitute the signal. FFT function is built into the spectrum analyzer for demodulating amplitude modulation on video signal.
- field strength** The intensity of an electromagnetic field at a given point, usually referred to in micro-volts per meter. The spectrum analyzer measurement of field strength requires the addition of an antenna correction factor to transform the power reading into voltage per meter.
- field strength meter (FSM)** A frequency selective heterodyne receiver capable of tuning to the frequency band of interest; in cable television, 5 to 550 MHz with indicating meter showing the magnitude input of voltage and a dial indicating the approximate frequency. Synonymous with signal level meter.
- frequency accuracy** In spectrum analyzer operation, the uncertainty with which the frequency of a signal or spectral component is indicated, either in an absolute sense or relative to some other signal or spectral component. Absolute and relative frequency accuracies are specified independently.
- frequency modulation (FM)** A form of modulation in which the frequency of the carrier is varied in accordance with the instantaneous value of the modulating signal. Measured as percent: (1) the ratio of the actual frequency swing defined as 100 percent modulation, expressed in percentage; (2) The ratio of half the difference between the maximum and minimum frequencies of the average frequency of an FM signal.
- frequency range** The range of frequencies over which the spectrum analyzer performance is specified. The maximum frequency range of many microwave spectrum analyzers can be extended with the application of external mixers.
- frequency resolution** The ability of a spectrum analyzer to separate closely spaced spectral components and display them individually. Resolution of equal amplitude components is determined by resolution bandwidth. Resolution of unequal amplitude signals is determined by resolution bandwidth and bandwidth selectivity.
- frequency response** The peak-to-peak variation in the displayed signal amplitude over a specified

center frequency range. The spectrum analyzer specification for frequency response, or flatness, gives the  $\pm$  dB uncertainty in the relative measurement of signals at different frequencies. It also may be specified relative to the calibrator signal.

**frequency span** In spectrum analyzer operation, the magnitude of the displayed frequency component. Span is represented by the horizontal axis of the display. Generally, frequency span is given as the total span across the full display. Some spectrum analyzers represent frequency span (scan width) as a per-division value.

**frequency stability** Stability is the ability of a frequency component to remain unchanged in frequency or amplitude over short- and long-term periods of time. In spectrum analyzers, stability refers to the local oscillator's ability to remain fixed at a particular frequency over time. The sweep ramp that tunes the local oscillator influences where a signal appears on the display. Any long-term variation in local oscillator frequency (drift) with respect to the sweep ramp causes a signal to shift its horizontal position on the display slowly. Shorter-term local oscillator instability can appear as random FM or phase noise on an otherwise stable signal.

**front-panel key** Keys, typically labeled, located on the front panel of an instrument. The key labels identify the function of the key activities. Numeric keys and step keys are two examples of front-panel keys. Also see soft keys.

**full span** A mode of operation in which the spectrum analyzer scans its entire frequency range.

**function** The action or purpose that a specific item is intended to perform or serve. The spectrum analyzer contains functions that can be executed via front-panel key selections, or through programming commands. The characteristics of these functions are determined by the firmware in the instrument. In some cases, a DLP (downloadable program) execution of a function allows you to execute the function from front-panel key selections.

**gain compression** The signal level at the input mixer of a spectrum analyzer where the displayed amplitude of the signal is a specific number of dB too low due just to mixer saturation. The signal level is generally specified for 1 dB or 0.5 dB compression and is usually between -3 dBm and -10 dBm. Analyzer gain compression is equal to

the input power minus the input attenuator setting.

**graticule line** Horizontal and vertical display lines representing absolute and relative frequencies or times (vertical) and amplitudes (horizontal) respectively. The top graticule is the amplitude reference level. The bottom graticule line represents 0 volts for linear scale or log scale factors of 10 dB/division or more. In 10 dB/division the bottom division is not calibrated. Spectrum analyzers with microprocessors allow reference level and marker values to be indicated in dBm, dBmV, dBmV, volts, and occasionally in watts.

**harmonic distortion** Unwanted distortion signal generated inside the spectrum analyzer which appear on the display as input signals. Harmonic distortion products are at frequencies related to the input by integer multipliers.

**Hertz (Hz)** A unit of frequency equivalent to a single period of one second.

**heterodyne** To mix an input signal with a local oscillator signal in an input mixer to produce an intermediate frequency signal (IF) that is processed for display.

**Hz** See Hertz.

**impedance** See input impedance.

**impedance matching** A method used to match the 50W input of a spectrum analyzer with the 75W cable television coaxial cable.

**input attenuator** An attenuator (also called an RF attenuator) between the input connector and the first mixer of a spectrum analyzer. The input attenuator is used to adjust the signal level incident to the first mixer, and to prevent gain compression due to high-level or broadband signals. It is also used to set the dynamic range by controlling the degree of internally-generated distortion. For some spectrum analyzers, varying the input attenuator settings changes the vertical position of the signal on the display, which then changes the reference level accordingly. In Hewlett-Packard microprocessor-controlled spectrum analyzers, the IF gain is changed to compensate for changes in input attenuator settings. Because of this, the signals remain stationary on the display, and the reference level is not changed.

- input impedance** The terminating impedance that the spectrum analyzer presents to the signal source. The nominal impedance for RF and microwave spectrum analyzers is usually 50Ω. For some systems, such as cable TV, 75Ω is standard. The degree of mismatch between the nominal and actual input impedance is called the VSWR (voltage standing wave ratio).
- limit line** A test limit made up of a series of line segments, positioned according to frequency and amplitude within the spectrum analyzer's measurement range. Two defined limit lines may be displayed simultaneously. One sets an upper test limit, the other sets a lower test limit. Trace data can be compared with the limit lines as the spectrum analyzer sweeps. If the trace data exceeds either the upper or lower limits, the spectrum analyzer displays a message or sounds a warning, indicating that the trace failed the test limits.
- local oscillator** A signal source in the spectrum analyzer used to mix with the input signals to produce IF signals. (See heterodyne.) The local oscillator is critical in sweep, scan, signal frequency accuracy and stability.
- log display** The display mode in which vertical deflection is a logarithmic function of the input-signal voltage. Log display is also referred to as logarithmic mode. The display calibration is set by selecting the value of the top graticule.
- marker** A visual indicator placed anywhere along the displayed trace. A marker readout indicates the absolute value of the trace frequency and amplitude at the marked point. The amplitude value is displayed with the currently selected units. See active marker.
- matching pad** An impedance matching device which converts the 75Ω impedance of cable television cable to 50Ω input of a microwave spectrum analyzer. Matching pads use resistive impedance to match, therefore, their insertion losses are higher than a matching transformer, but has an upper frequency limit of 1.8 GHz.
- matching transformer** An impedance matching device which converts the 75Ω impedance of the cable television cable to 50Ω input of a microwave spectrum analyzer. The transformer usually has an upper frequency response of 500 MHz. Also, the circuit to provide impedance match between the 75Ω subscriber drop to the 300Ω impedance of a television or FM receiver.
- maximum input level** The maximum signal power that may be safely applied to the input of a spectrum analyzer. Typically 1 W (-30 dBm).
- measurement range** The ratio, expressed in dB, of the maximum signal level that can be measured (usually the maximum safe input level) to the lowest achievable average noise level. This ratio is almost always much greater than can be realized in a single measurement. Refer also to dynamic range.
- megahertz (MHz)** One million cycles per second.
- menu** The spectrum analyzer functions that appear on the display and are selected by pressing front-panel keys. These selections may evoke a series of other related functions that establish groups called menus.
- microsecond** One millionth of a second. The front panel keys show micro as m.
- microwave** Signals generally above 1000 MHz.
- noise** The low level limitation to analyzer measurements which appears as a continually changing band of energy below CW signals. Noise may come from the input or be generated by the spectrum analyzer itself. Also, a random burst of electrical energy or interference which may produce a "salt-and-pepper" pattern over a television picture. Heavy noise is sometimes called "snow."
- noise temperature** The temperature that corresponds to a given noise level from all sources, including thermal noise, source noise and induced noise.
- oscilloscope** A measurement instrument which displays input voltages with respect to time.
- pass band** Usually refers to the IF, or resolution bandwidth.
- preamplifier** An external, low-noise-figure amplifier that improves system spectrum analyzer (preamplifier/ spectrum analyzer) sensitivity over that of the spectrum analyzer itself.
- radio frequency (RF)** An electromagnetic signal above the audio and below the infrared frequencies.
- random noise** See noise.

**reference level** The calibrated vertical position on the display used as a reference for amplitude measurement in which the amplitude of one signal is compared with the amplitude of another regardless of the absolute amplitude of either. Also see graticule.

**resolution** A measure of picture resolving capabilities of a television system determined primarily by bandwidth, scan rates and aspect ratio. Relates to fineness of details perceived. See frequency resolution and resolution bandwidth.

**resolution bandwidth** The ability of a spectrum analyzer to display adjacent responses discretely (hertz, hertz decibel down). This term is used to identify the width of the resolution bandwidth filter of a spectrum analyzer at some level below the minimum insertion-loss point (maximum deflection point on the display). The 3 dB resolution bandwidth is specified; for others, it is the 6 dB resolution bandwidth.

**RS-232** A means of communication between devices, such as printers, plotters, computers, modems, and spectrum analyzers. (The devices need to have RS-232 interfaces). Unlike the HP-IB interface bus, the RS-232 interface bus is used for serial (not parallel) transmission.

**shape factor** See bandwidth selectivity.

**sidebands** Additional frequencies generated by the modulation process, which appear on the display as signals related to the modulating signal.

**signal level meter (SLM)** See field strength meter.

**signal generator** An electronic instrument which produces audio or radio frequency signals for test, measurement or alignment purposes.

**signal-to-noise ratio** The ratio, expressed in decibels, of the peak voltage of the signal of interest to the root-mean-square voltage of the noise in that signal.

**single-sweep mode** The spectrum analyzer sweeps once when trigger conditions are met. Each sweep is initiated by pressing an appropriate front-panel key, or by sending a programming command.

**softkey** Key labels displayed on a screen or monitor that are activated by mechanical keys surrounding the display or located on a keyboard. Softkey selections usually evoke menus that are written into the program software. Front-panel

key selections determine which menu (set of softkeys) appears on the display.

**span** The stop frequency minus the start frequency. The span setting determines the horizontal-axis scale of the spectrum analyzer display.

**span accuracy** The uncertainty of the indicated frequency separation of any two signals on the display.

**spectrum analyzer** A scanning receiver with a display that shows a plot of frequency versus amplitude of the signals being measured. Modern spectrum analyzers are often microprocessor controlled and feature powerful signal measurement capabilities.

**spurious signals** Any undesired signals such as images, harmonics, and beats.

**stop/start frequency** In spectrum analyzer operation, terms used in association with the stop and start points of the frequency measurement range. Together they determine the span of the measurement range.

**sweep generator** An electronic instrument whose output signal varies in frequency between two preset or adjustable limits, at a rate that is also adjustable. This "swept" signal is used to perform frequency response measurements when used in conjunction with appropriate peripheral accessories.

**sweep time** The time it takes the local oscillator to tune across the selected span. Sweep time directly affects how long it takes to complete a measurement.

**trace** See active trace.

**units** Dimensions on the measured quantities. Units usually refer to amplitude quantities because they can be changed. In spectrum analyzers with microprocessors, available units are dBm (dB relative to 1 mW dissipated in the nominal input impedance of the spectrum analyzer), dBmV (dB relative to 1 mV), dBV (dB relative to 1 mV), volts, and, in some spectrum analyzers, watts.

**video** In spectrum analyzer operation, a term describing the output of a spectrum analyzer's envelope detector. The frequency range extends from 0 Hz to a frequency that is typically well beyond the widest resolution bandwidth available in the spectrum analyzer. However, the ultimate bandwidth of the video chain is determined by

the setting of the video filter. Video is also a term describing the television signal composed of visual and aural carriers.

**video average** The digital averaging of spectrum analyzer trace information. It is available only on spectrum analyzers with digital displays.

**video bandwidth** In spectrum analyzer operation, the cut-off frequency (3 dB point) of an adjustable low-pass filter in the video circuit. When the video bandwidth is equal to or less than the resolution bandwidth, the video circuit cannot fully respond to the more rapid fluctuations of the output of the envelope detector. The result is a smoothing of the trace, or a reduction in the peak-to-peak excursion, of broadband signals such as noise and pulsed RF when viewed in broadband mode. The degree of averaging or smoothing is a function of the ratio of the video bandwidth to the resolution bandwidth.

**video filter** A post-detection, low-pass filter that determines the bandwidth of the video amplifier. It is used to average or smooth a trace. Refer also to video bandwidth.

**wave-form monitor** A special-purpose oscilloscope which shows the video signal amplitude in the time domain.

**zero span** A setting where the local oscillator remains fixed at a given frequency. The spectrum analyzer becomes a fixed-tuned receiver to show signal amplitude variations as a function of time. To avoid loss of signal information, the resolution bandwidth is set as wide as the signal bandwidth. To avoid smoothing the video bandwidth is set wider than the resolution bandwidth.

# Appendix C

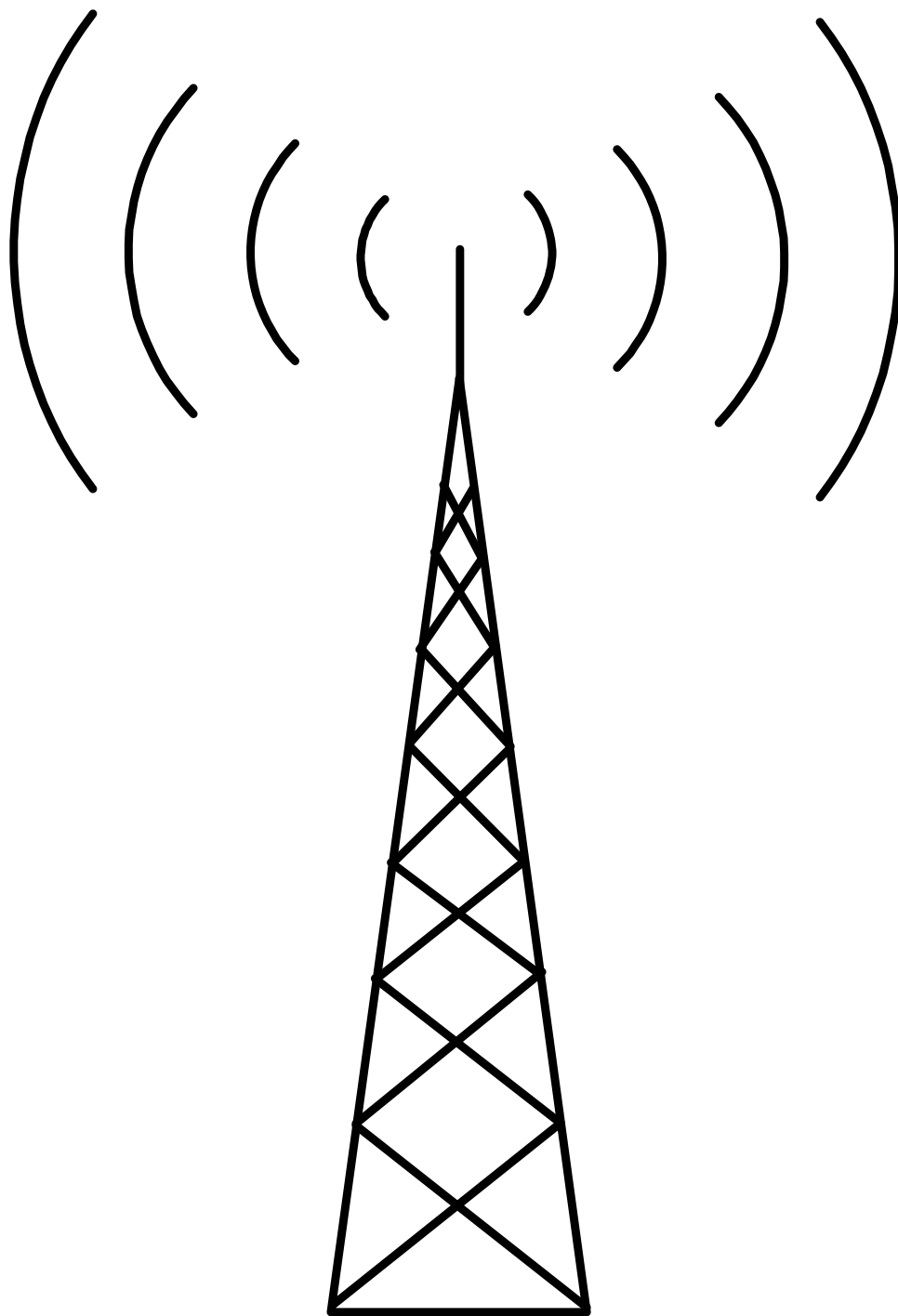
## Index

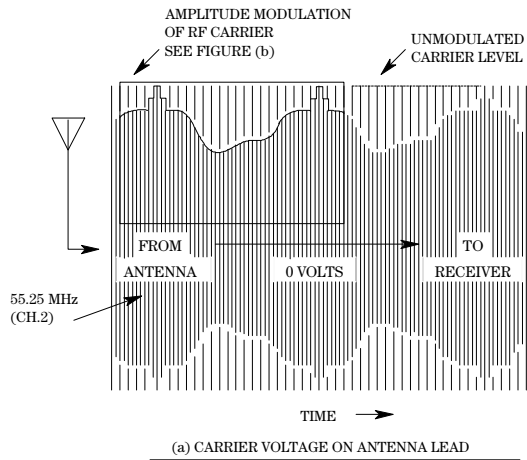
Absolute signal level	2-8	Drift	2-2
AC voltmeter	3-4, 3-6	Dynamic range	3-5
Accuracy considerations	2-2, 4-2	Electromagnetic compatibility	3-6
Adapter	4-3	Electromagnetic interference	B-2
Adjacent channel level	2-8	Fast Fourier transform	4-16
Adjacent signal level	2-8	FFT	4-16, 4-17
AM	2-11, 2-13, 2-19	Field strength	2-24
Amplitude modulation	1-1, 2-17, 2-19	Field strength meter	3-4
Antenna correction factor	2-24	Flatness	2-8
Aural carrier	1-4, 2-8, 4-6	Frequency accuracy	2-2, 2-3
Aural carrier frequency	4-4	Frequency counter	3-1, 4-5
Aural carrier level	4-4	Frequency domain	1-3
Aural signal	1-1	Frequency modulation	2-2
Automatic gain control	2-9	Frequency spectrum	1-3
Automatic slope control	2-9	Frequency stability	2-2
Bandpass filter	4-7	Frequency step size	4-10
Bandwidth	2-11, 3-5	Full system check	4-4
C/N measurement	2-11, 4-11, 4-12	Harmonic distortion	B-3
Cable television distribution system	1-4	Headend measurements	4-1
Calibration	4-3	Horizontal sync pulse	1-3
Carrier	1-3	HP 85711B CATV Measurements Personality	4-2
Carrier level	2-23	HP 85716A CATV Measurements Personality	4-2
Carrier signal	2-6	HP 85916A CATV Measurements Personality	4-2
Carrier-to-noise	2-11	HP 85905A Preamplifier	4-2
Center frequency	4-10	HP 8591E RF Spectrum Analyzer	4-2
Channel allocations	4-4	HP 8593E Microwave Spectrum Analyzer	4-2
Channel frequency response	2-20	HRC	4-4
Characteristic impedance	2-4	Hum	2-16, 2-17, 4-15, 4-16
Co-channel interference	2-15, 4-13, 4-14	Impedance	2-4, 2-26
Coherent disturbances	2-15, 2-17, 4-17	Impedance conversion tables	A-1
Color	1-4	Impedance conversions	2-5
Composite second order	2-17, 4-17	Impedance matching	4-1, 4-3
Composite triple beat	2-17, 4-17	In-channel frequency response	2-21, 4-20, 4-23
Counter	3-6	Ingress	2-15, 4-13
Crossmod	2-18, 4-19	Instrumentation	3-1
Crossmodulation	2-18, 4-19	Interference	2-15, 2-26, 4-13
CSB/CTB	2-18	Interference outside the system	2-15, 2-23
CSO	2-17, 4-17, 4-18	Intermodulation	2-17
CTB	2-17, 4-17, 4-18	IRC	4-4
DB	2-5, 4-1	Low frequency disturbances	2-15, 4-15
DBV	2-24	Marker	B-3
DBm	2-5	Matching pad	B-3
DBmV	2-5	Matching transformer	B-3
Decibel	2-4	Measurement	
Depth of modulation	2-21, 2-22, 4-25	absolute	4-1
Direct pickup	2-15	accessories	4-2
Distribution measurements	4-1	accuracy	4-2



personality	4-2	display dynamic range	B-1
procedures	4-2	display fidelity	B-2
relative	4-1	dynamic range	B-2
Measurement parameters	2-1	fast Fourier transform	B-2
Measurements	4-1	frequency accuracy	2-2, 2-3, B-2
Measuring		frequency range	B-2
C/N	4-7	frequency resolution	B-2
carrier-to-noise	4-10	frequency response	2-9, B-2
distortion	2-19	frequency span	B-2
Network analysis	2-1, 2-2, 2-26, 3-1	frequency stability	2-2, B-2
Noise	2-9, 2-10, 2-26	front-panel key	B-2
Noise figure	2-10, 2-13	full span	B-2
Noise figure meter	3-6	function	B-2
Noise marker	4-12	gain compression	B-2
Noise meter	3-6	graticule line	B-2
Noise power corrections	4-7	input attenuator	B-3
Noise power density	2-10, 4-7	input impedance	B-3
Noise terminology	2-13	limit line	B-3
NTSC	1-1, 2-19	log display	B-3
Oscilloscope	3-3	marker	B-3
Overload	4-12, 4-17	maximum input level	B-3
PAL	1-1, 2-19	measurement range	B-3
Phase	2-2	menu	B-3
Power	2-4, 3-4	noise	B-3
Power meter	3-4, 3-6	options	4-2
Preamplifier	4-12	pass band	B-4
Preset	4-4	reference level	B-4
Program video	4-22	resolution bandwidth	B-4
Proof-of-performance	2-1, 4-1	single-sweep mode	B-4
Radiation	2-15, 2-23, 2-26	softkey	B-4
Residual FM	2-2	span	B-4
Resolution	3-5	span accuracy	B-4
Resolution and video bandwidths	4-15	stop/start frequency	B-4
Response	2-9	sweep time	B-4
RF carrier	1-1, 2-21	units	B-4
RF power	2-5	video	B-4
RS-232 interface	B-4	video average	B-5
SECAM	1-1	video bandwidth	B-5
Second order intermodulation	2-17	video filter	B-5
Signal analysis	2-1, 2-26, 3-1	zero span	B-5
Signal frequency	2-2	Spectrum viewer	3-5
Signal level	2-4	Standard	4-4
Signal power	2-4	Suggested equipment	4-2
Signal strength meter	3-6	Sweep generator	B-4
Sinx/x video test signal	4-23	System frequency response	2-23, 4-27
Slope	2-9	System sweep	2-23
Spectrum analyzer	3-5, 3-6, 4-1	Test instrumentation	3-6
active marker	B-1	Third order intermodulation	2-17
active trace	B-1	Tilt	2-9
amplitude accuracy	B-1	Trace	B-4
bandwidth selectivity	B-1	Tuned voltmeter	3-4, 3-6
command	B-1	TV broadcast signal	1-1
continuous sweep mode	B-1	TV raster	1-1
delta marker	B-1	Units	B-4

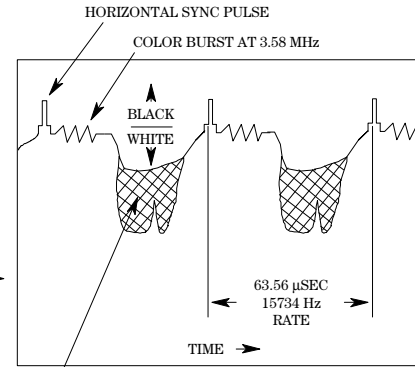
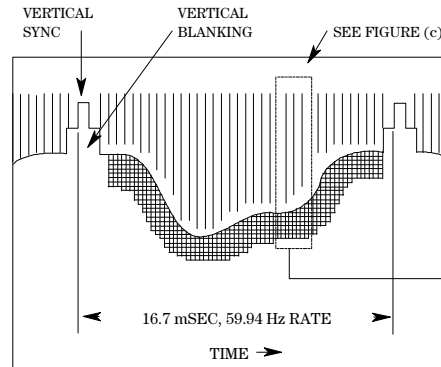
Vestigial sideband	1-1, 1-3
Video	1-1, 1-3
Visual carrier	1-4
Visual carrier frequency	4-4
Visual carrier level	4-4
VITS	4-22, 4-23
Voltage	3-4



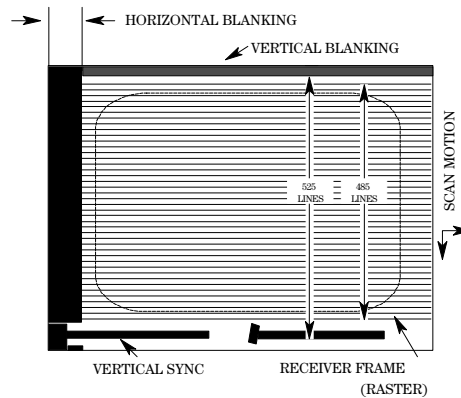


a) Television video is amplitude modulated on the RF carrier and received by the antenna. The TV broadcast carrier contains the information for luminance (black and white), chrominance (color), and synchronizing (format) signals required by the TV receiver.

b) Amplitude envelope of the signal shows the vertical scan frame sync pulses at a 59.94 Hz rate which establish the vertical frame in the TV screen

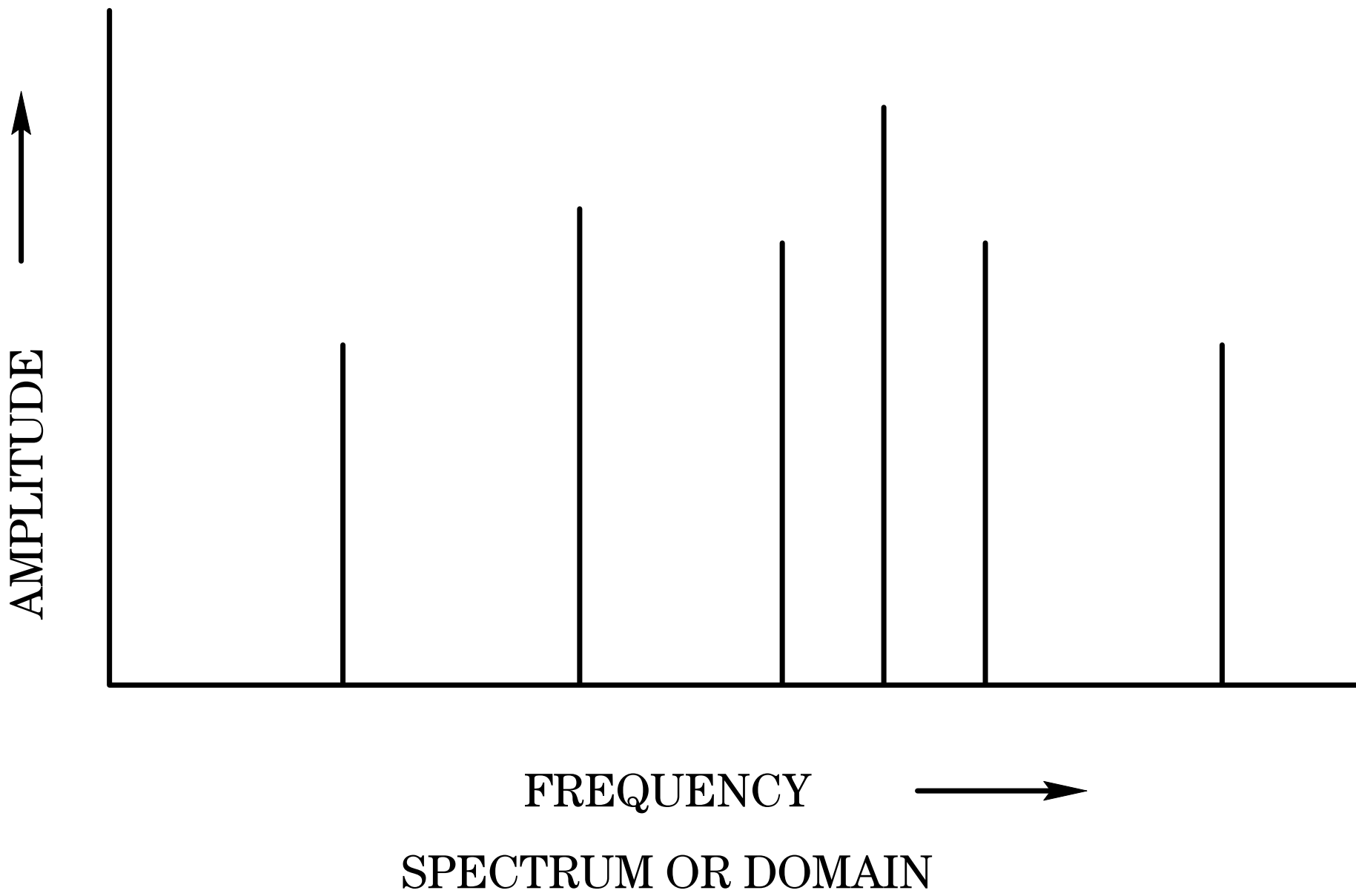


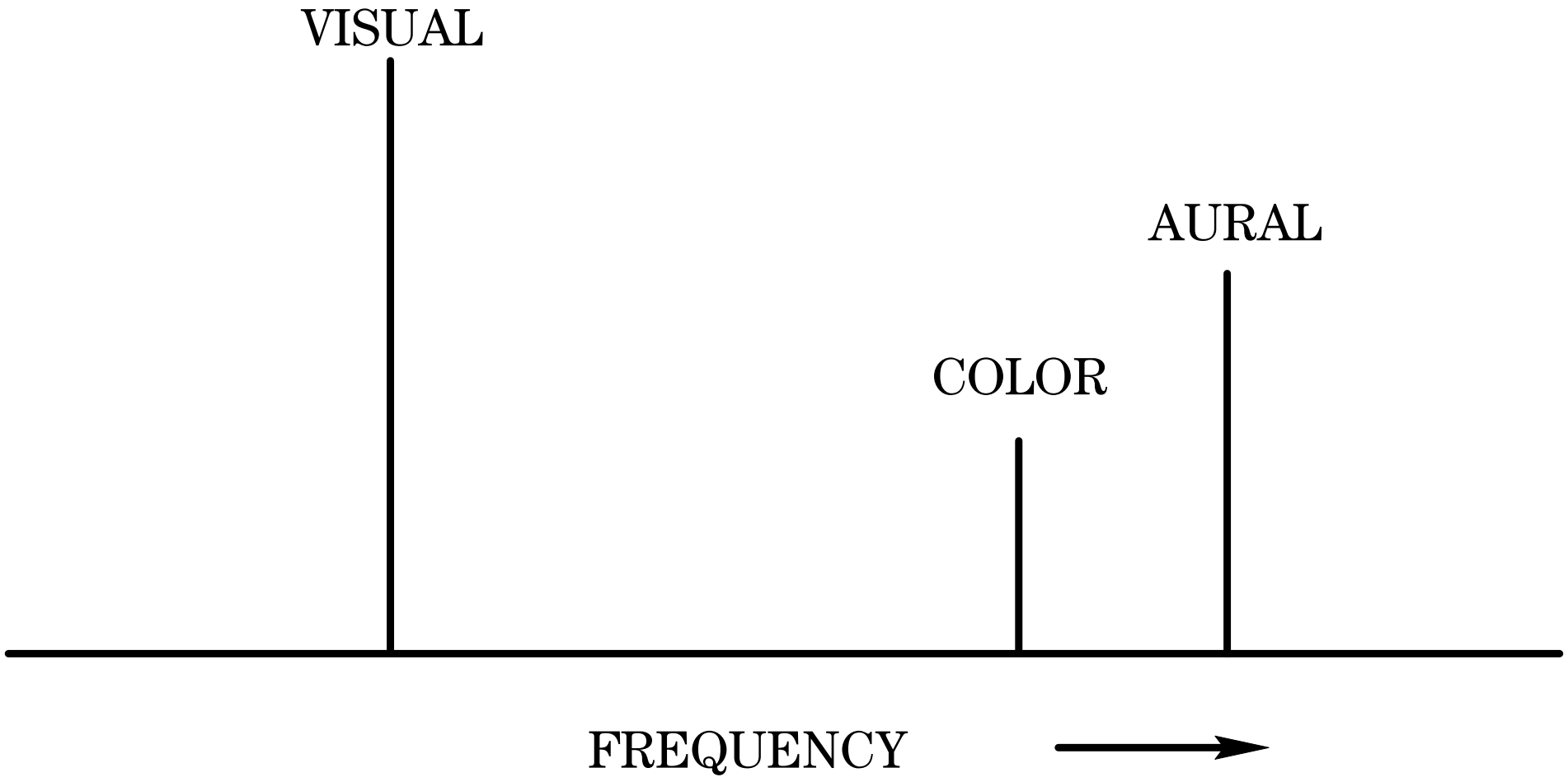
LUMINANCE AND CHROMA FOR ONE LINE

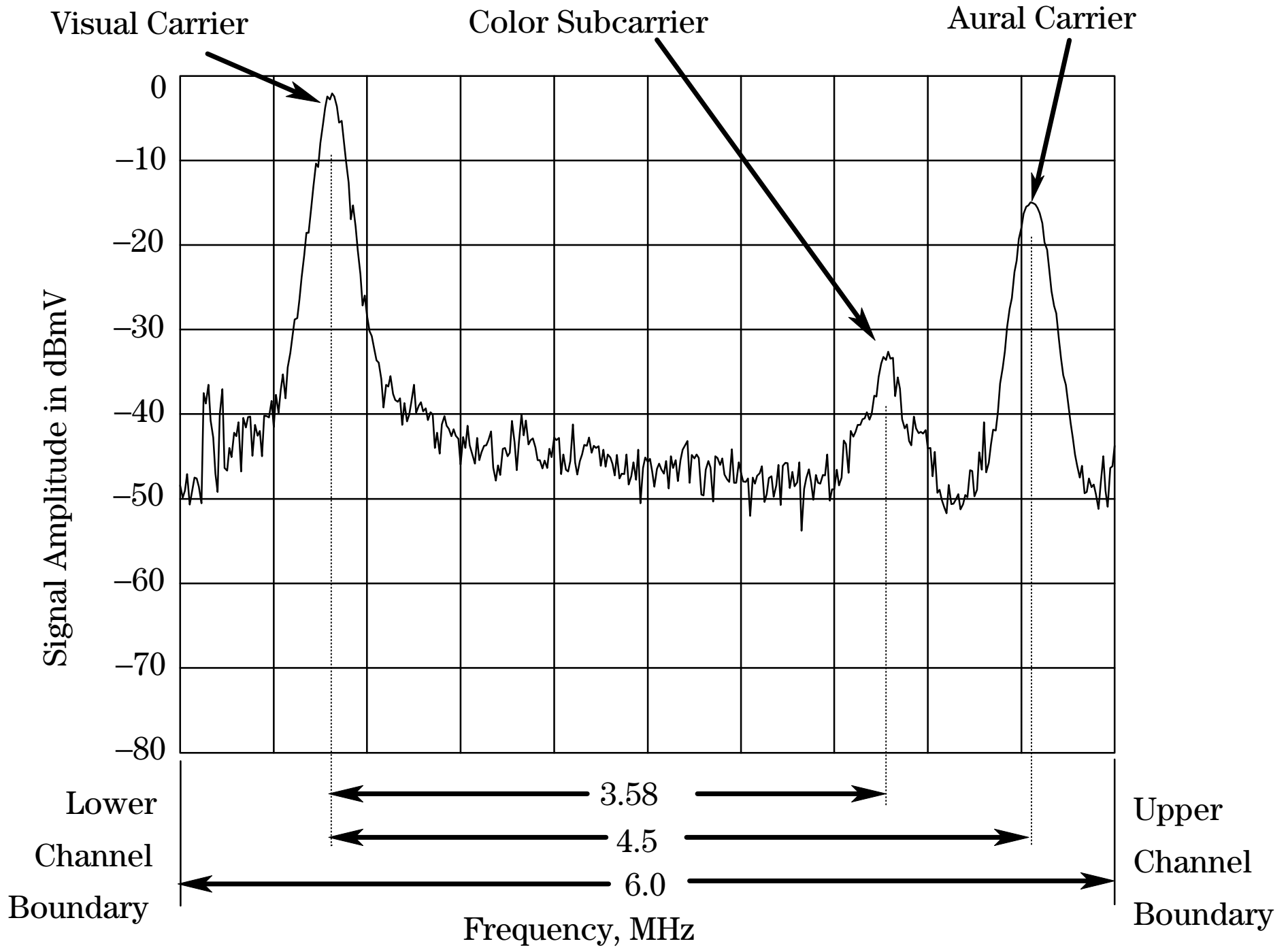


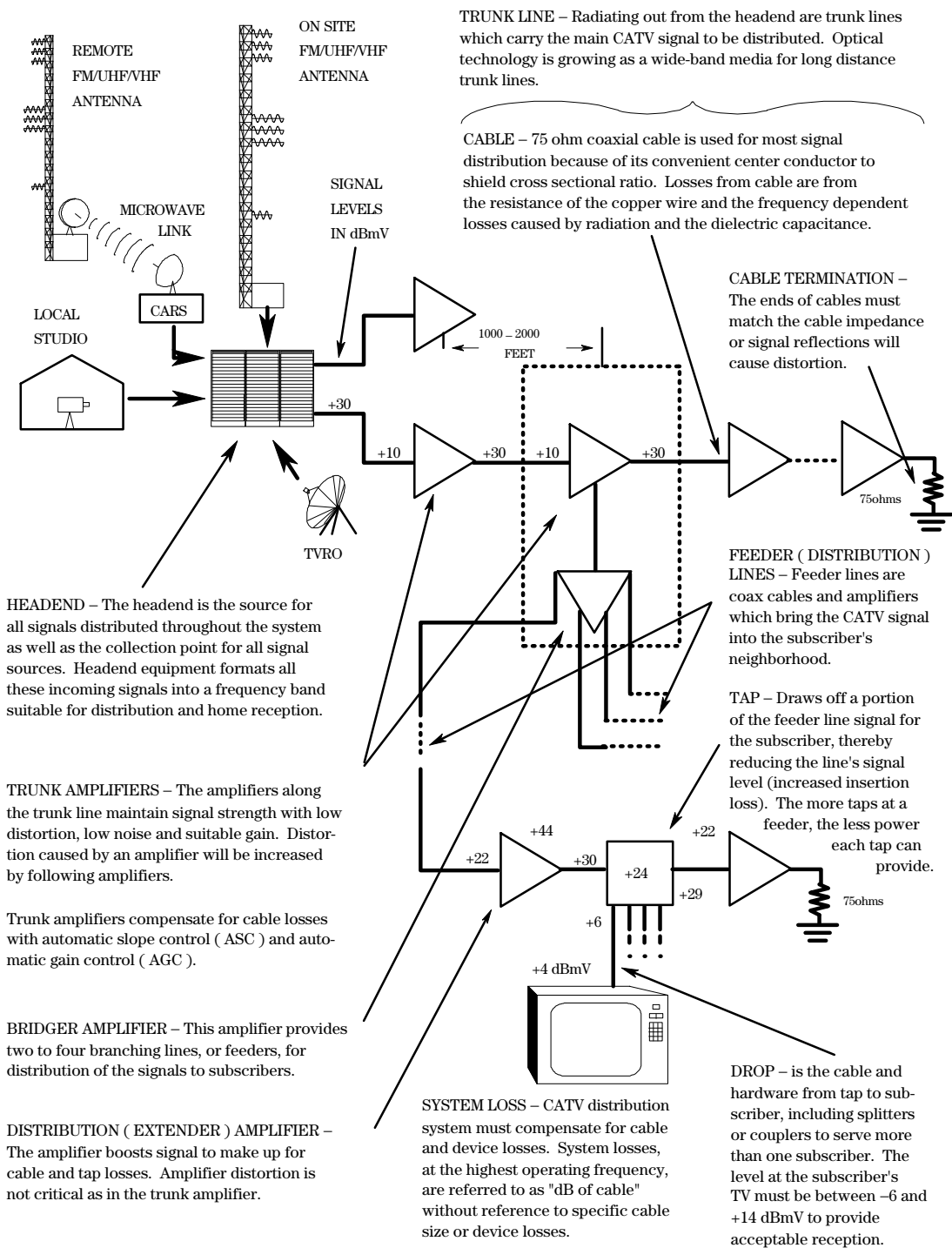
c) Horizontal sync pulses and luminance information on two of the 525 horizontal lines for a single frame TV frame.

d) The resulting TV picture with areas outside the picture used to transmit synchronizing and test information









**TRUNK LINE** – Radiating out from the headend are trunk lines which carry the main CATV signal to be distributed. Optical technology is growing as a wide-band media for long distance trunk lines.

**CABLE** – 75 ohm coaxial cable is used for most signal distribution because of its convenient center conductor to shield cross sectional ratio. Losses from cable are from the resistance of the copper wire and the frequency dependent losses caused by radiation and the dielectric capacitance.

**CABLE TERMINATION** – The ends of cables must match the cable impedance or signal reflections will cause distortion.

**HEADEND** – The headend is the source for all signals distributed throughout the system as well as the collection point for all signal sources. Headend equipment formats all these incoming signals into a frequency band suitable for distribution and home reception.

**TRUNK AMPLIFIERS** – The amplifiers along the trunk line maintain signal strength with low distortion, low noise and suitable gain. Distortion caused by an amplifier will be increased by following amplifiers.

Trunk amplifiers compensate for cable losses with automatic slope control (ASC) and automatic gain control (AGC).

**BRIDGER AMPLIFIER** – This amplifier provides two to four branching lines, or feeders, for distribution of the signals to subscribers.

**DISTRIBUTION (EXTENDER) AMPLIFIER** – The amplifier boosts signal to make up for cable and tap losses. Amplifier distortion is not critical as in the trunk amplifier.

**FEEDER (DISTRIBUTION) LINES** – Feeder lines are coax cables and amplifiers which bring the CATV signal into the subscriber's neighborhood.

**TAP** – Draws off a portion of the feeder line signal for the subscriber, thereby reducing the line's signal level (increased insertion loss). The more taps at a feeder, the less power each tap can provide.

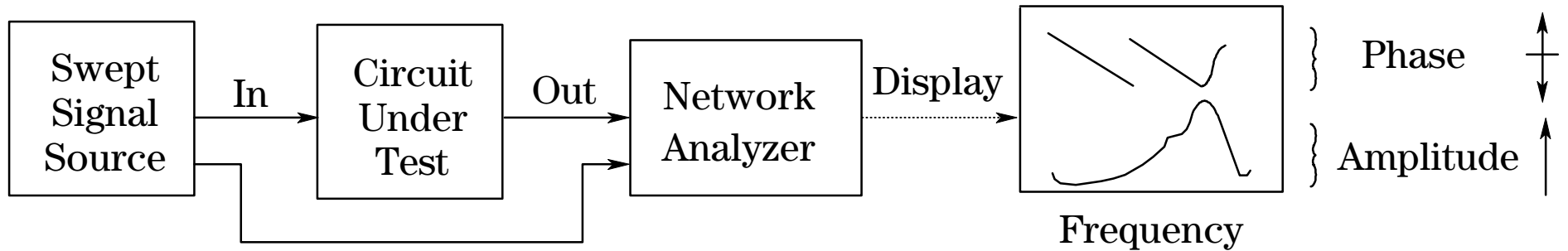
**SYSTEM LOSS** – CATV distribution system must compensate for cable and device losses. System losses, at the highest operating frequency, are referred to as "dB of cable" without reference to specific cable size or device losses.

**DROP** – is the cable and hardware from tap to subscriber, including splitters or couplers to serve more than one subscriber. The level at the subscriber's TV must be between -6 and +14 dBmV to provide acceptable reception.



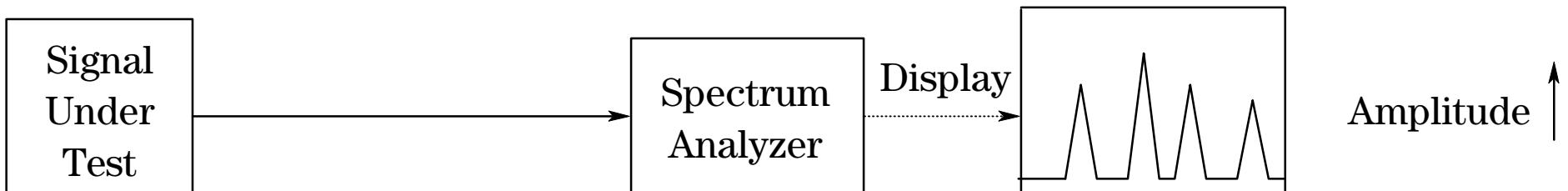
## a) Network Analysis

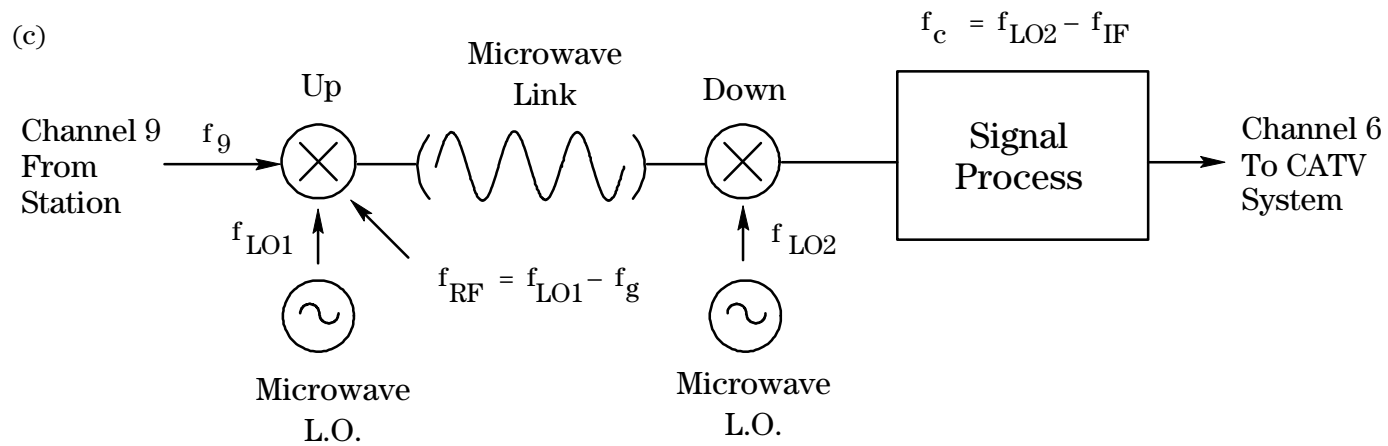
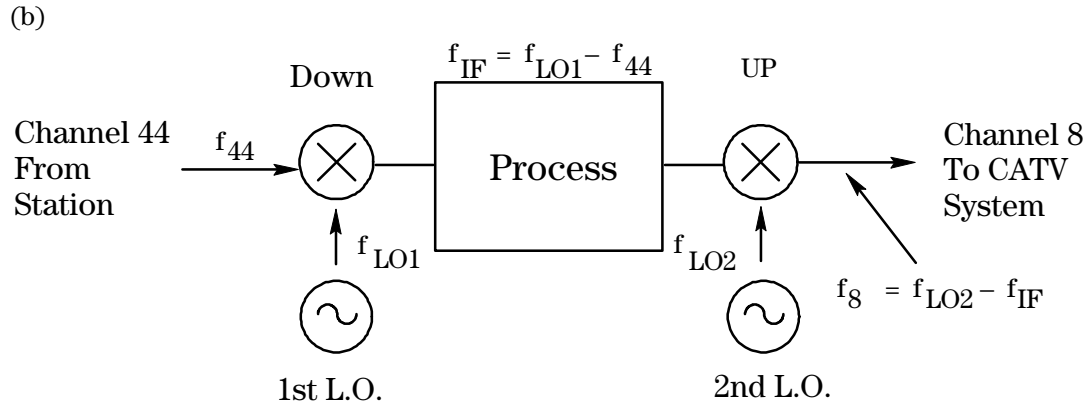
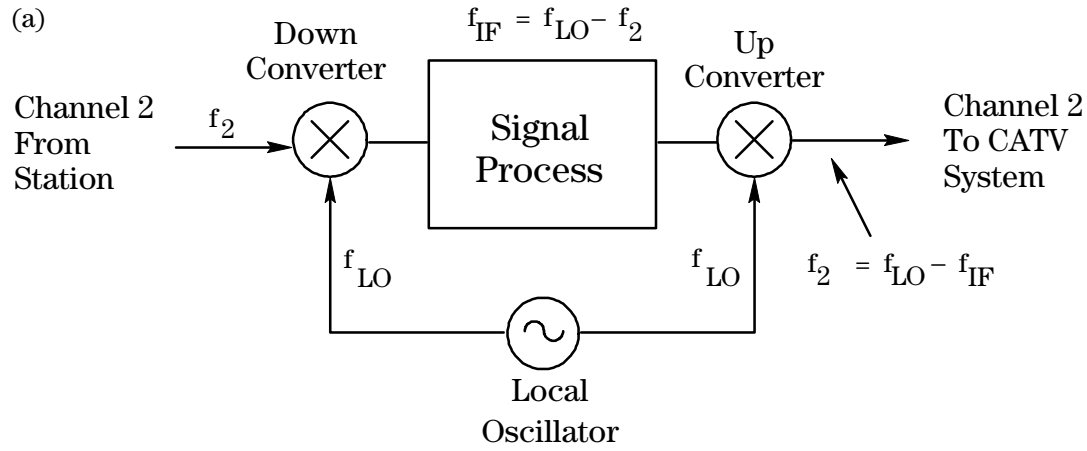
Network Analysis is characterizing a circuit by displaying the phase and amplitude changes on a known input signal

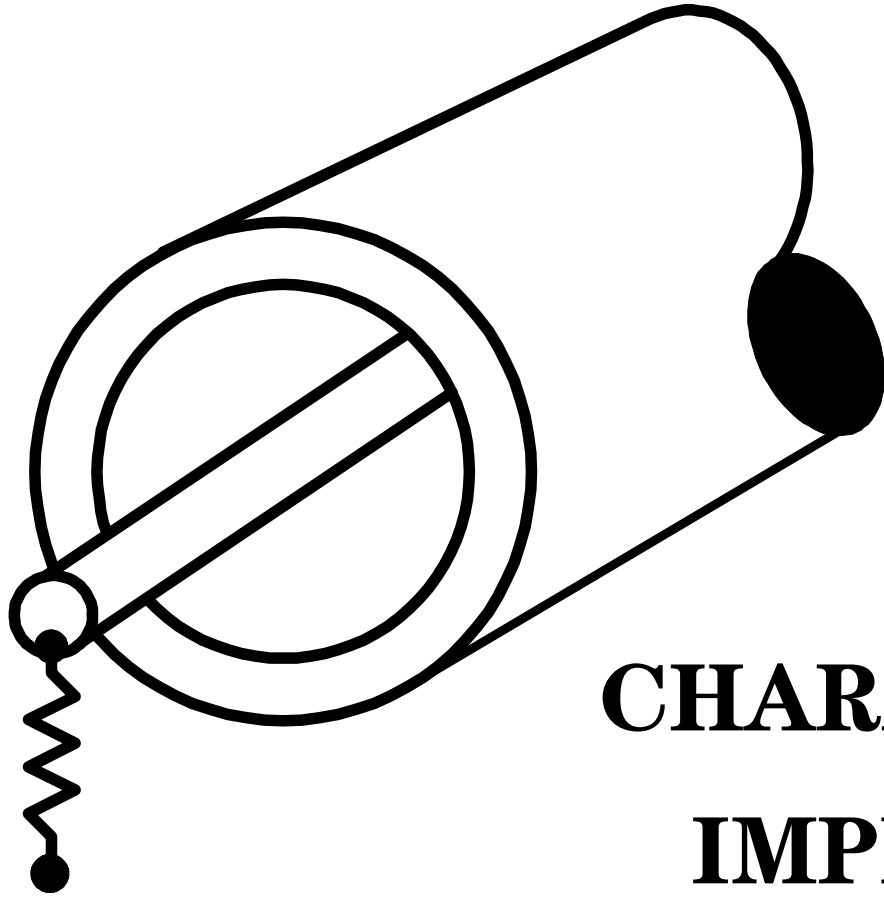


## b) Signal Analysis

Signal analysis displays the amplitude spectrum of a test signal.

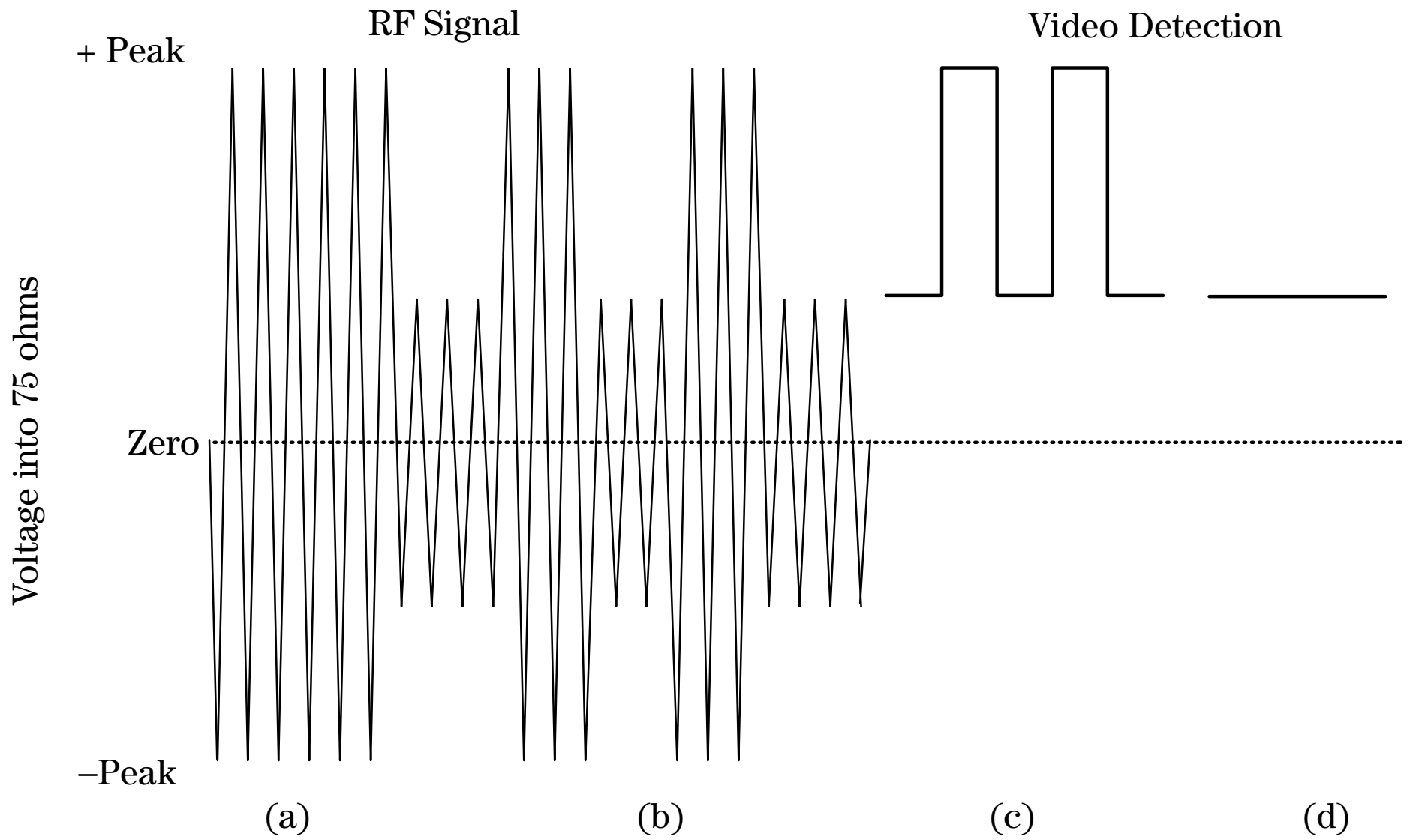


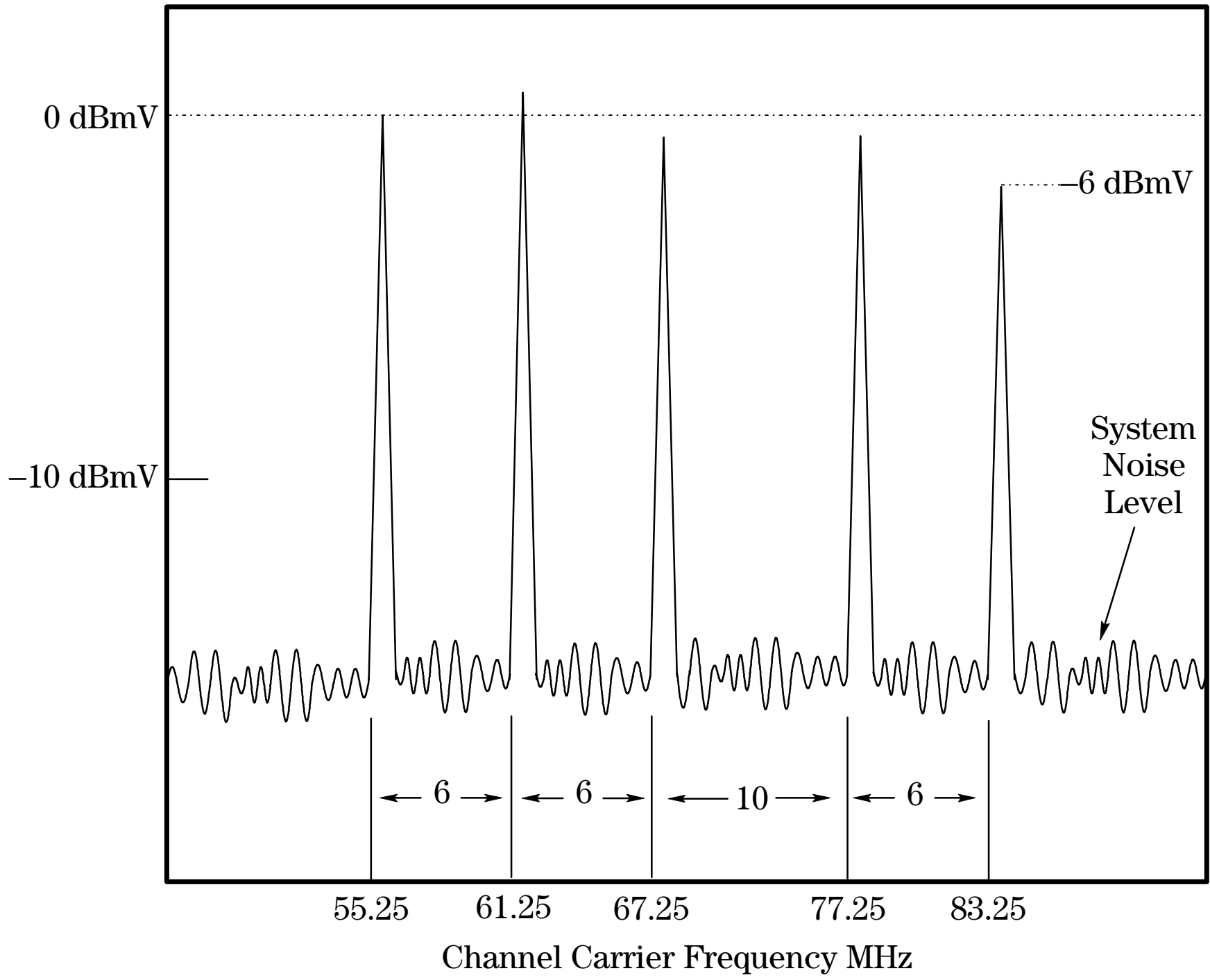


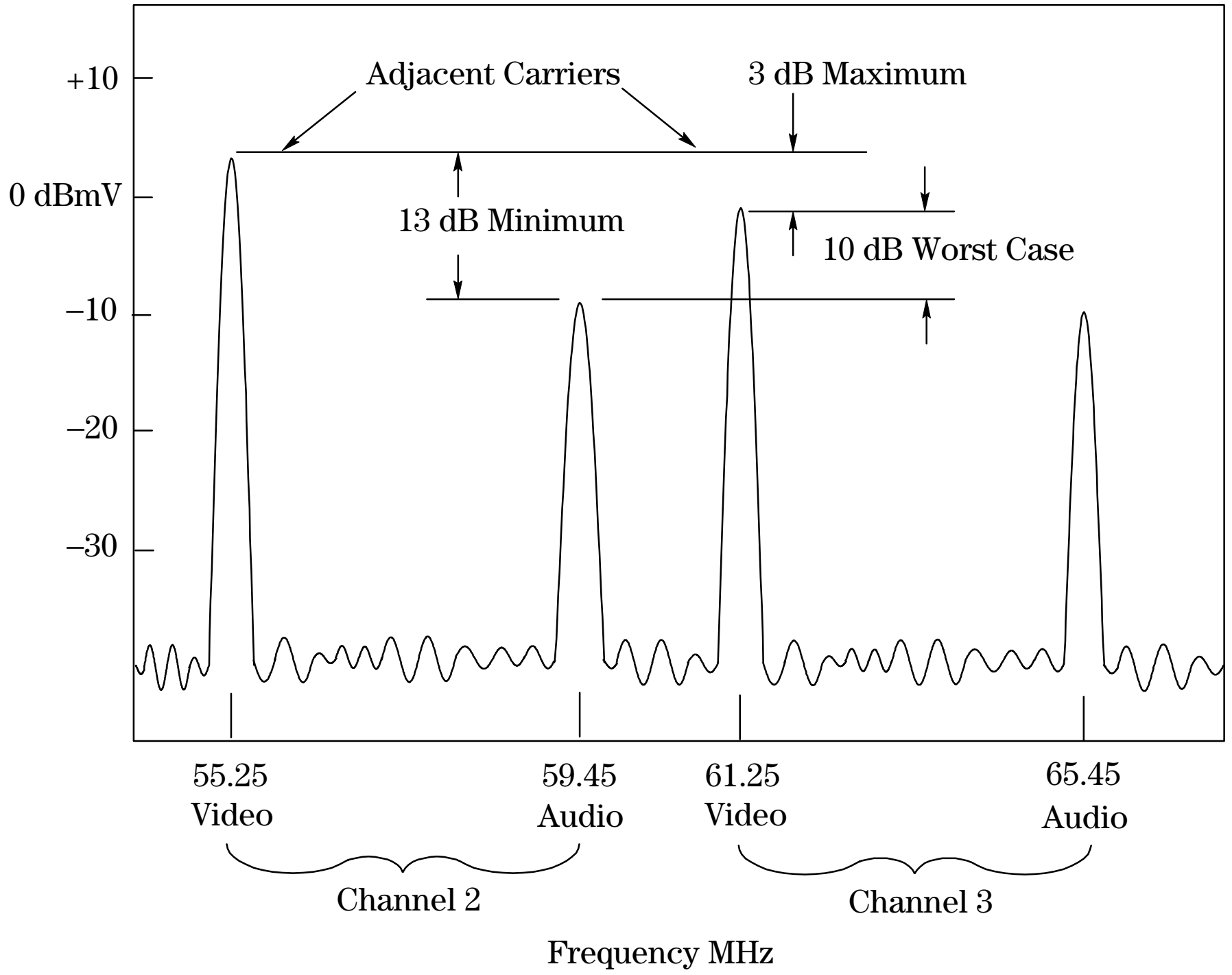


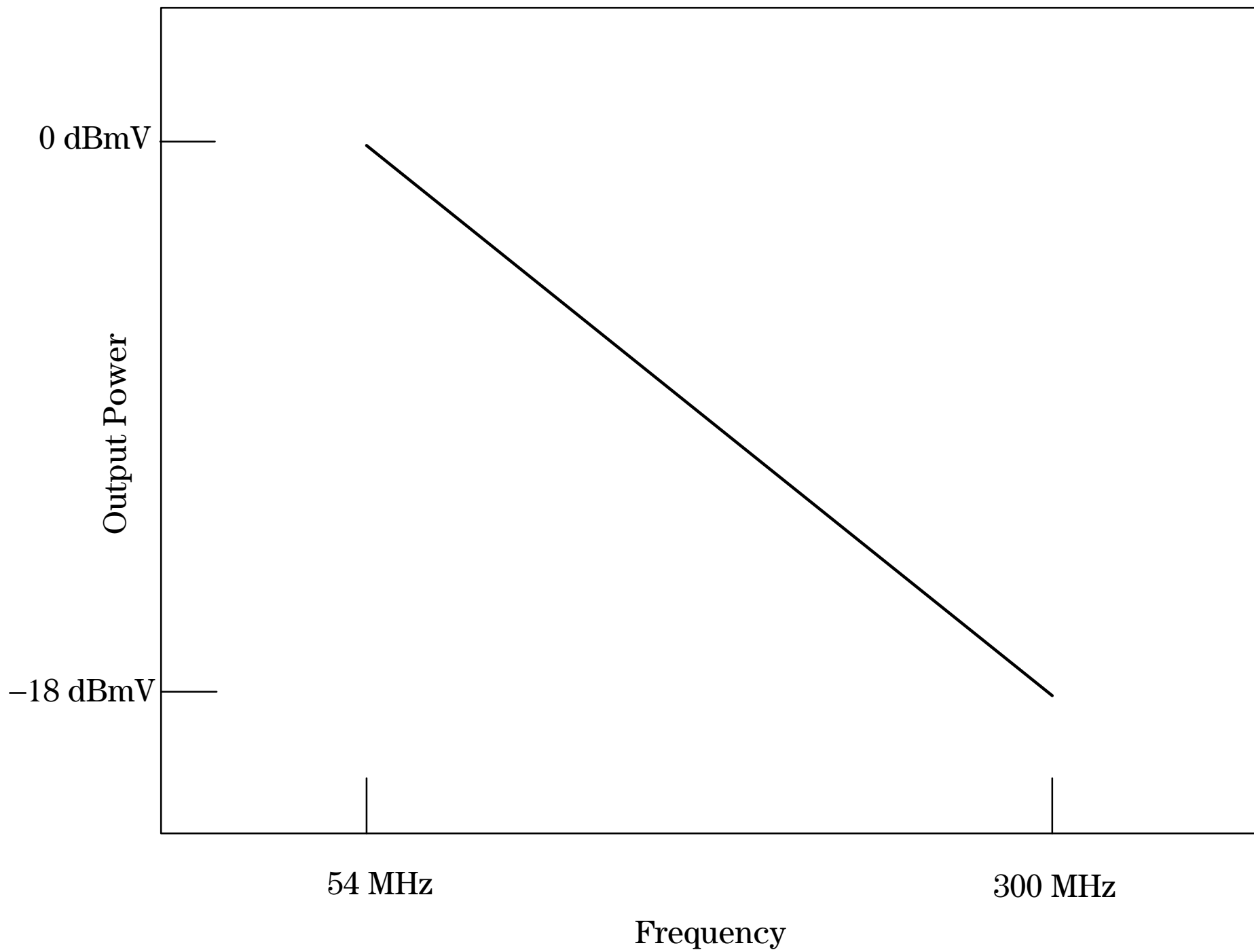
**CHARACTERISTIC  
IMPEDANCE**

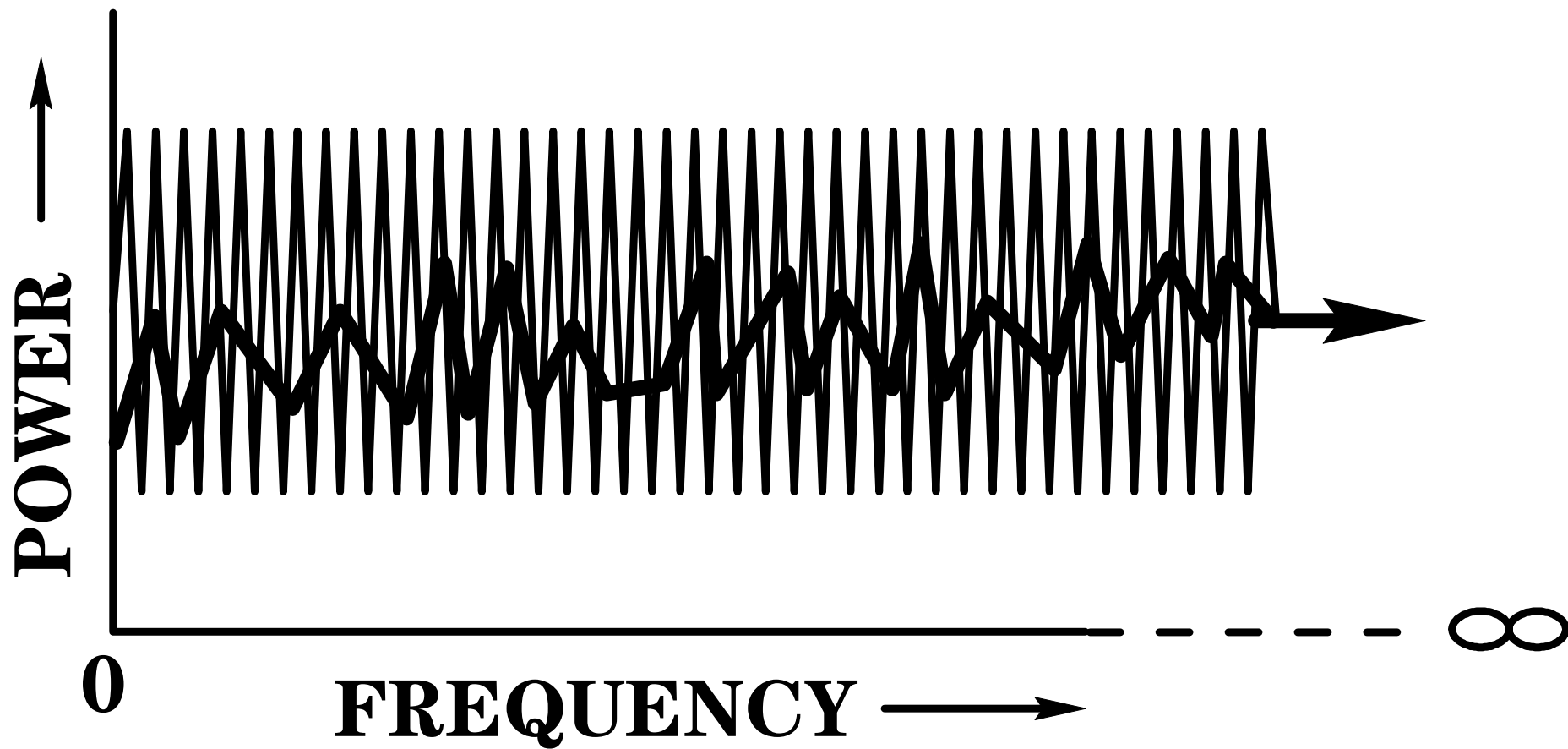
**75  
OHMS**





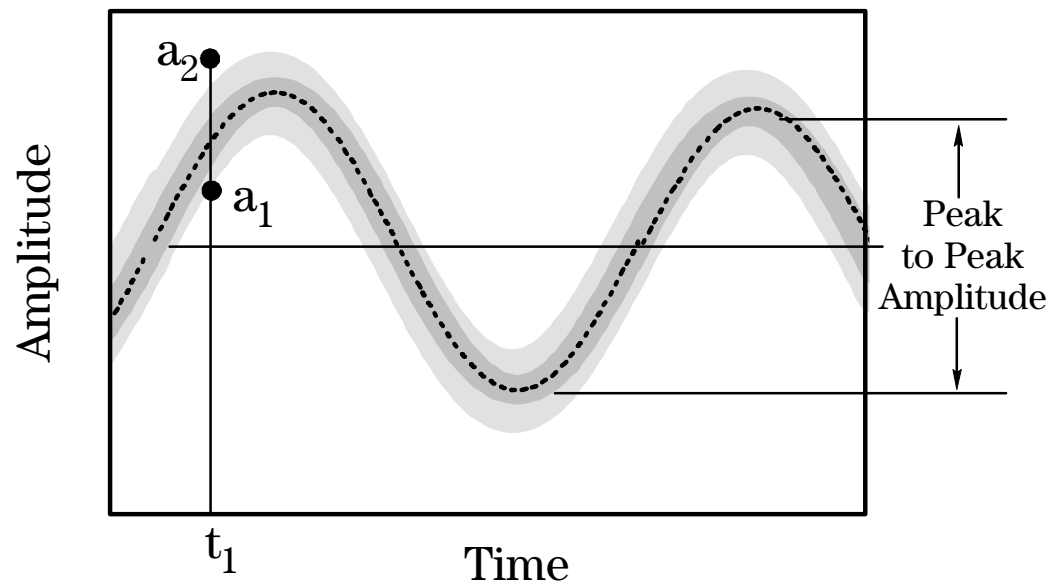




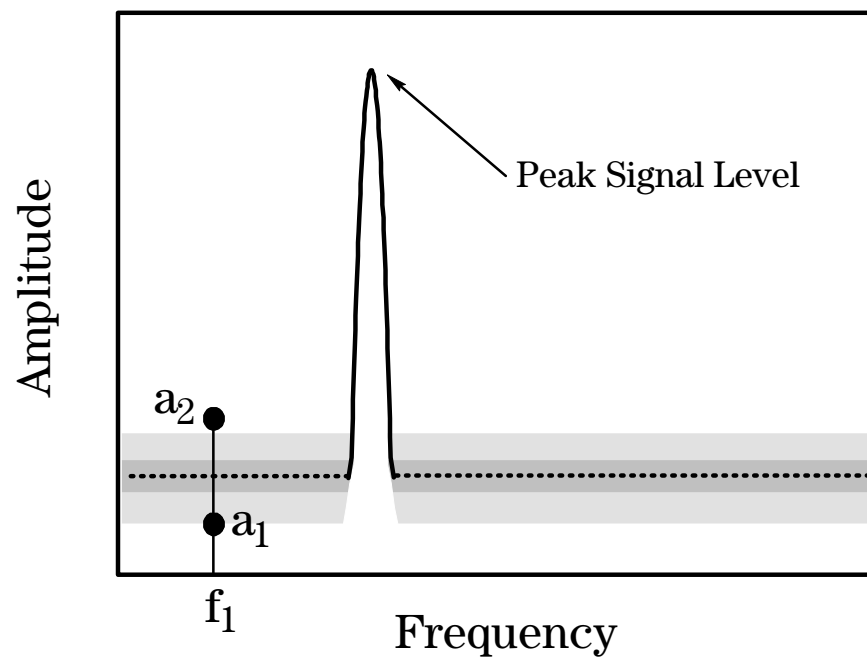


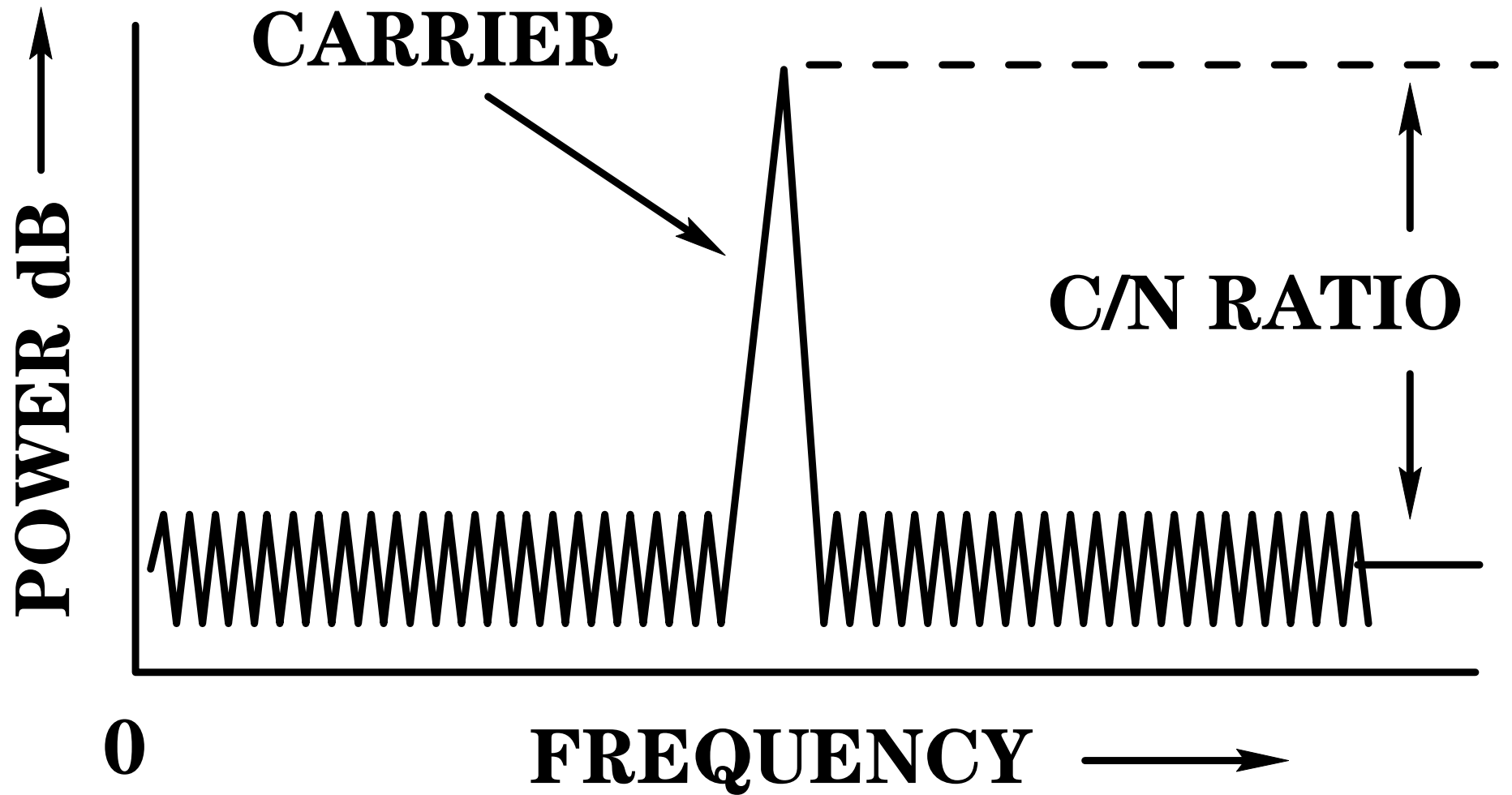


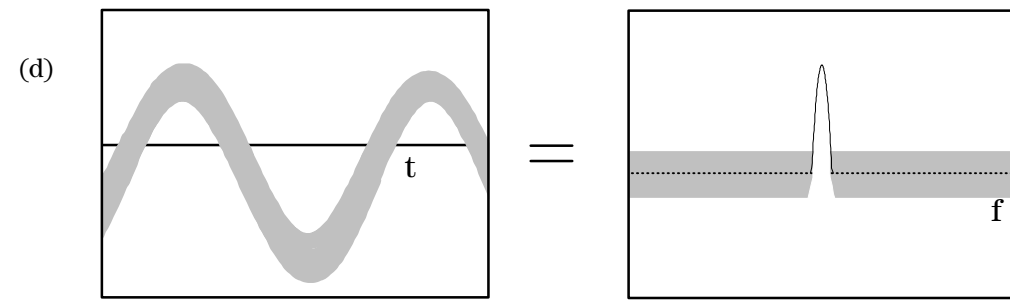
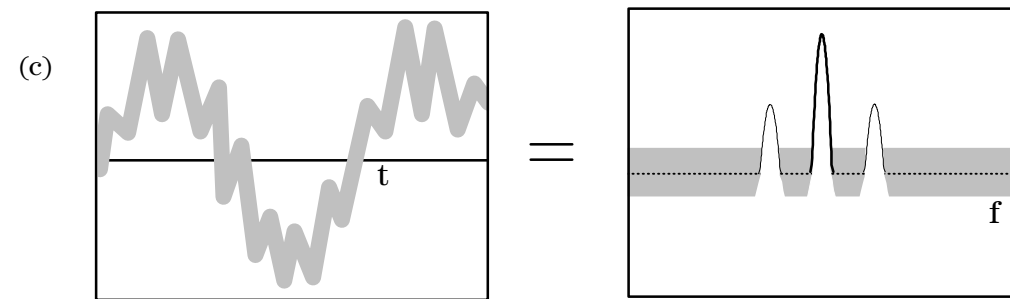
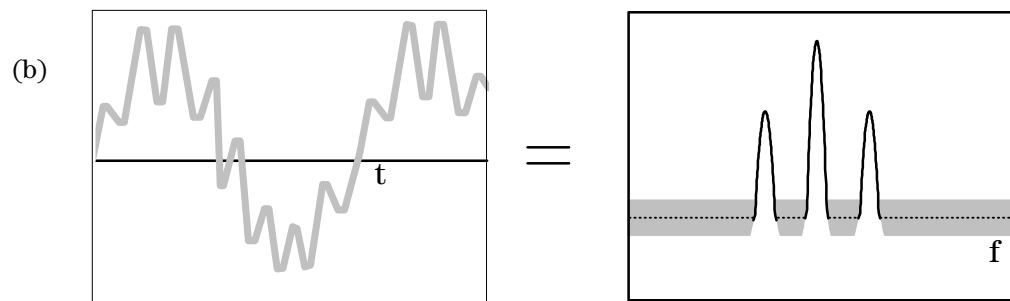
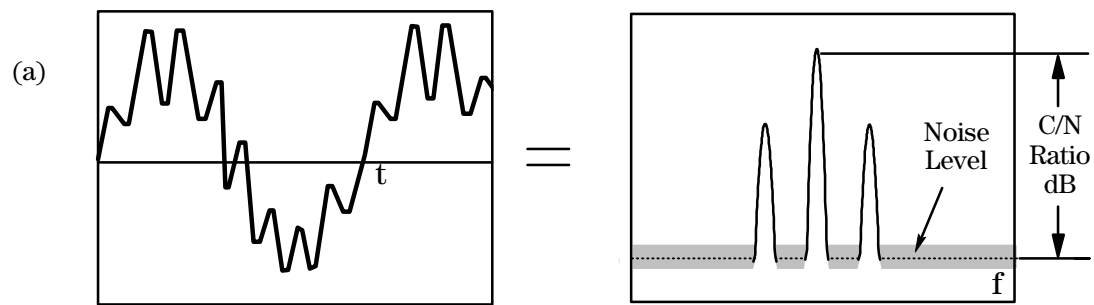
(a)



(b)

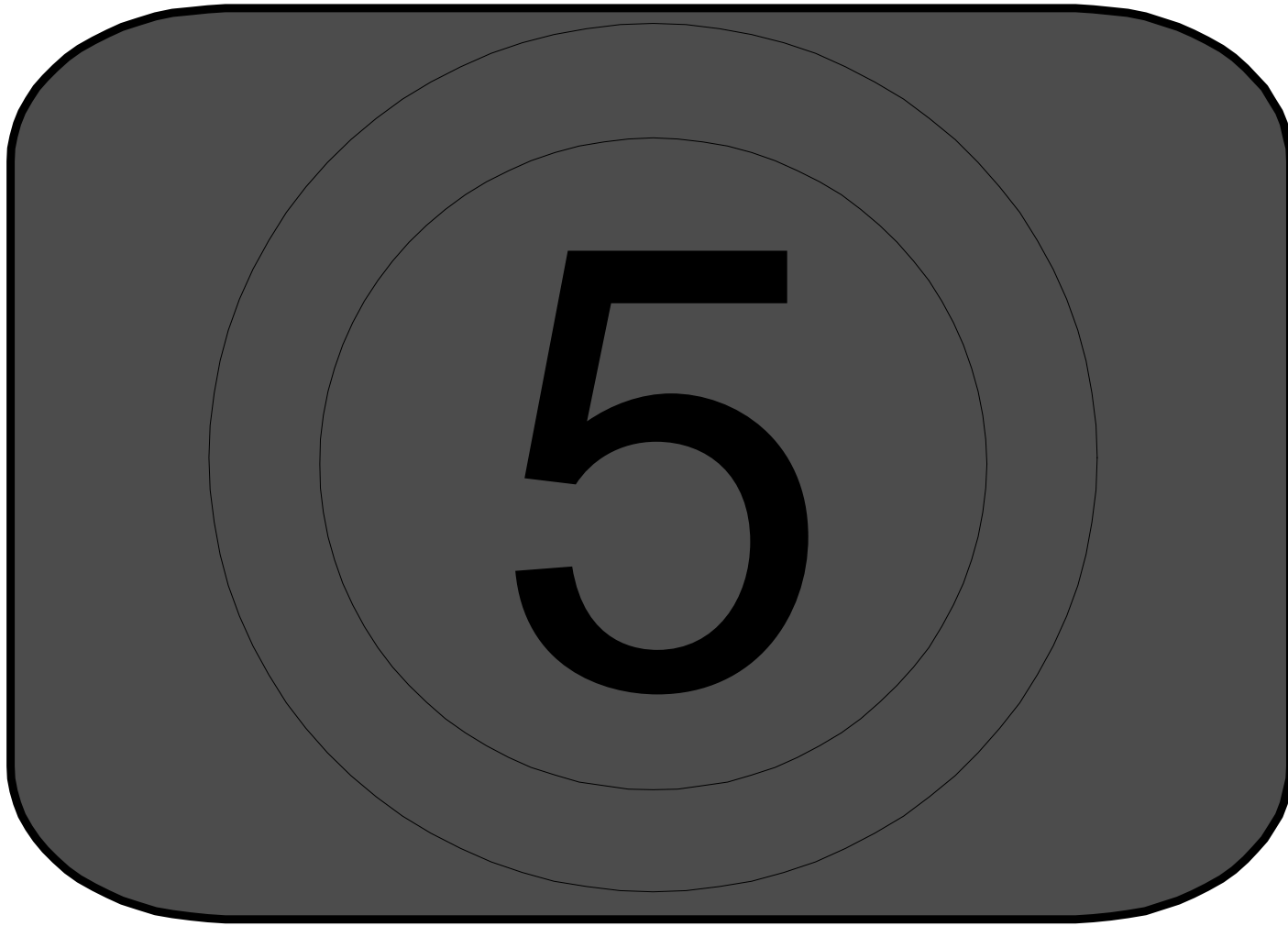




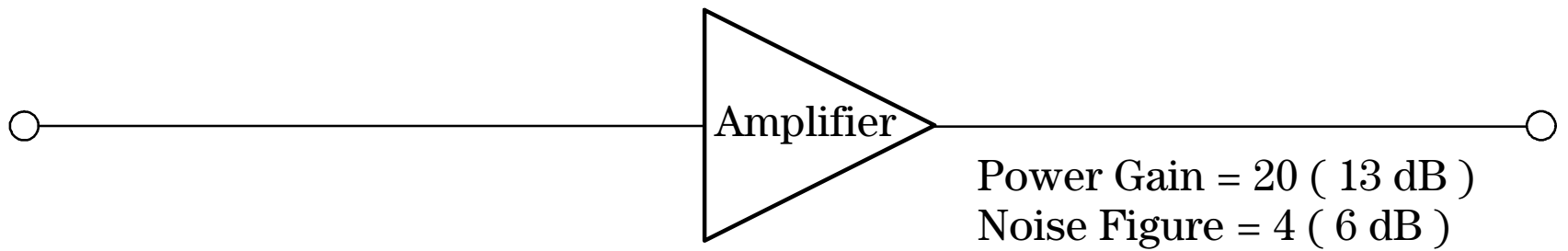
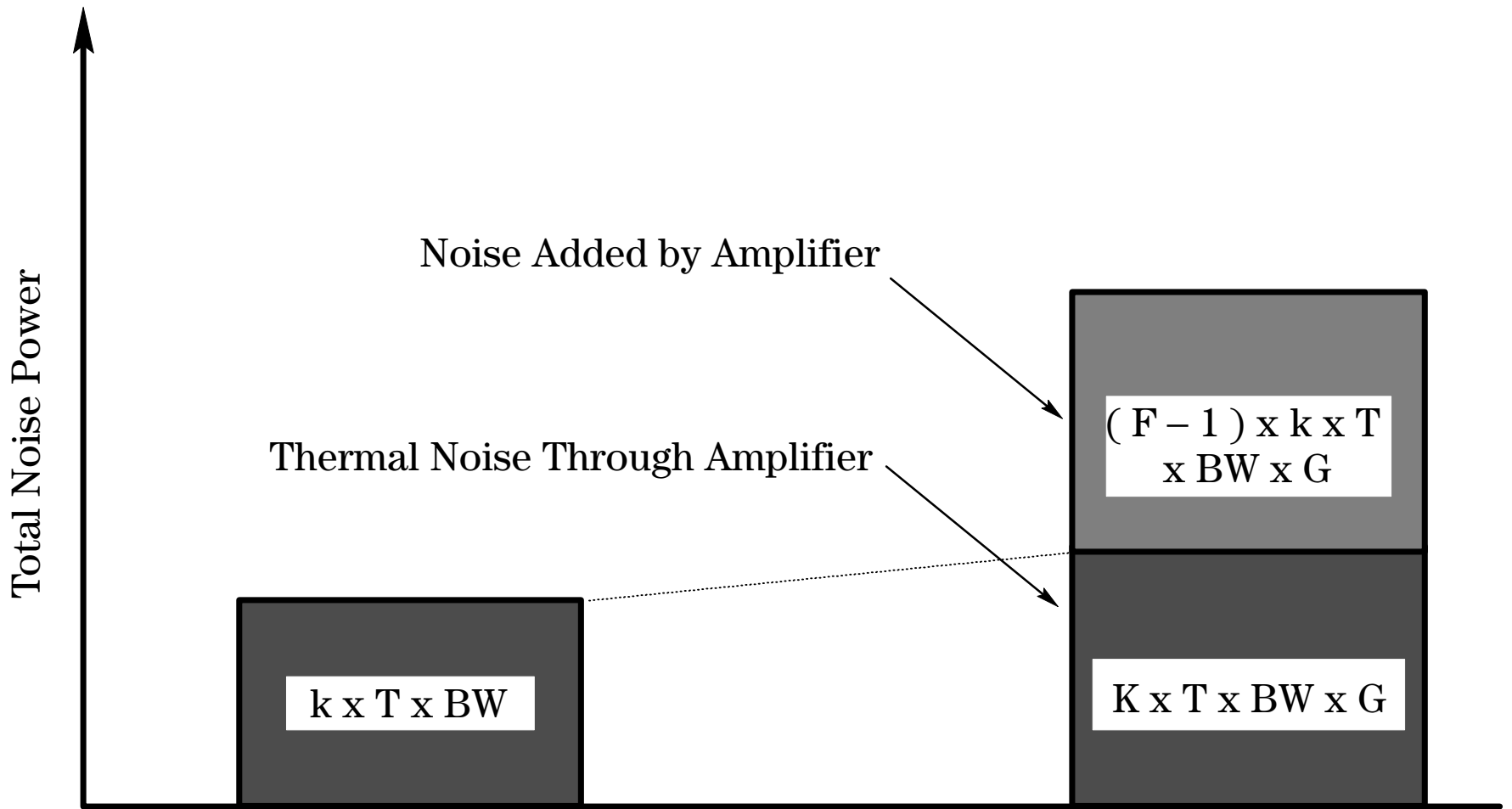


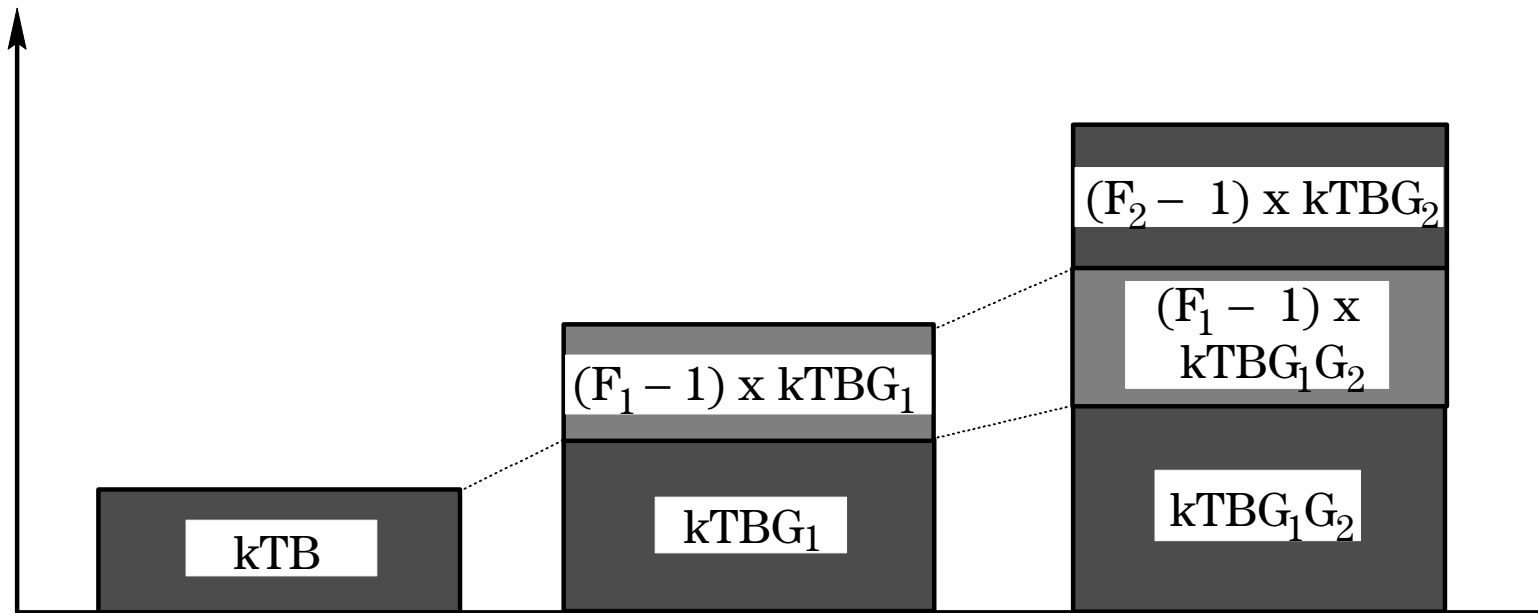
Time  $\rightarrow$

Frequency  $\rightarrow$



**LOW C/N RATIO**





(a)



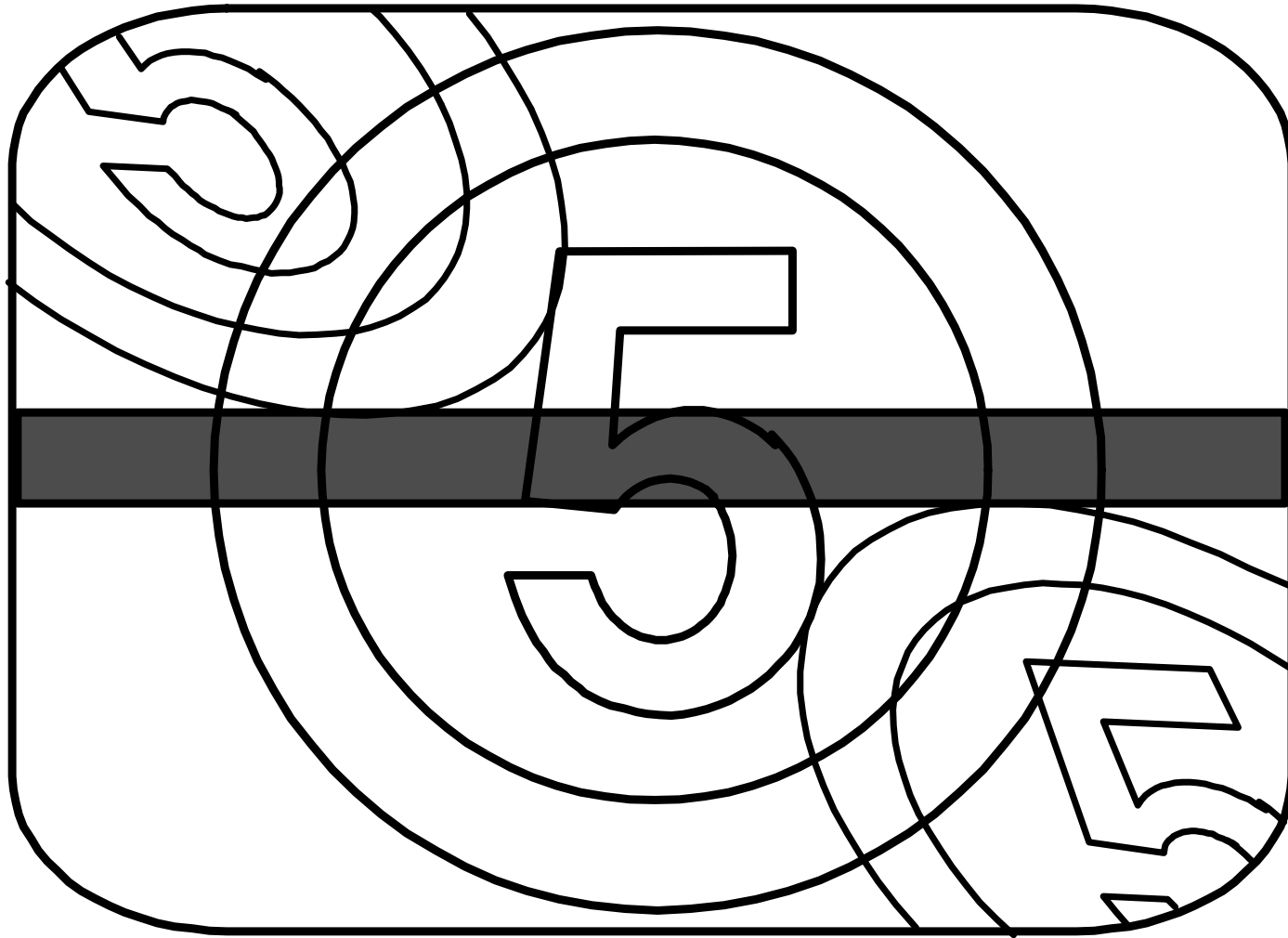
(b)

Total System Noise Figure n Amplifier is:

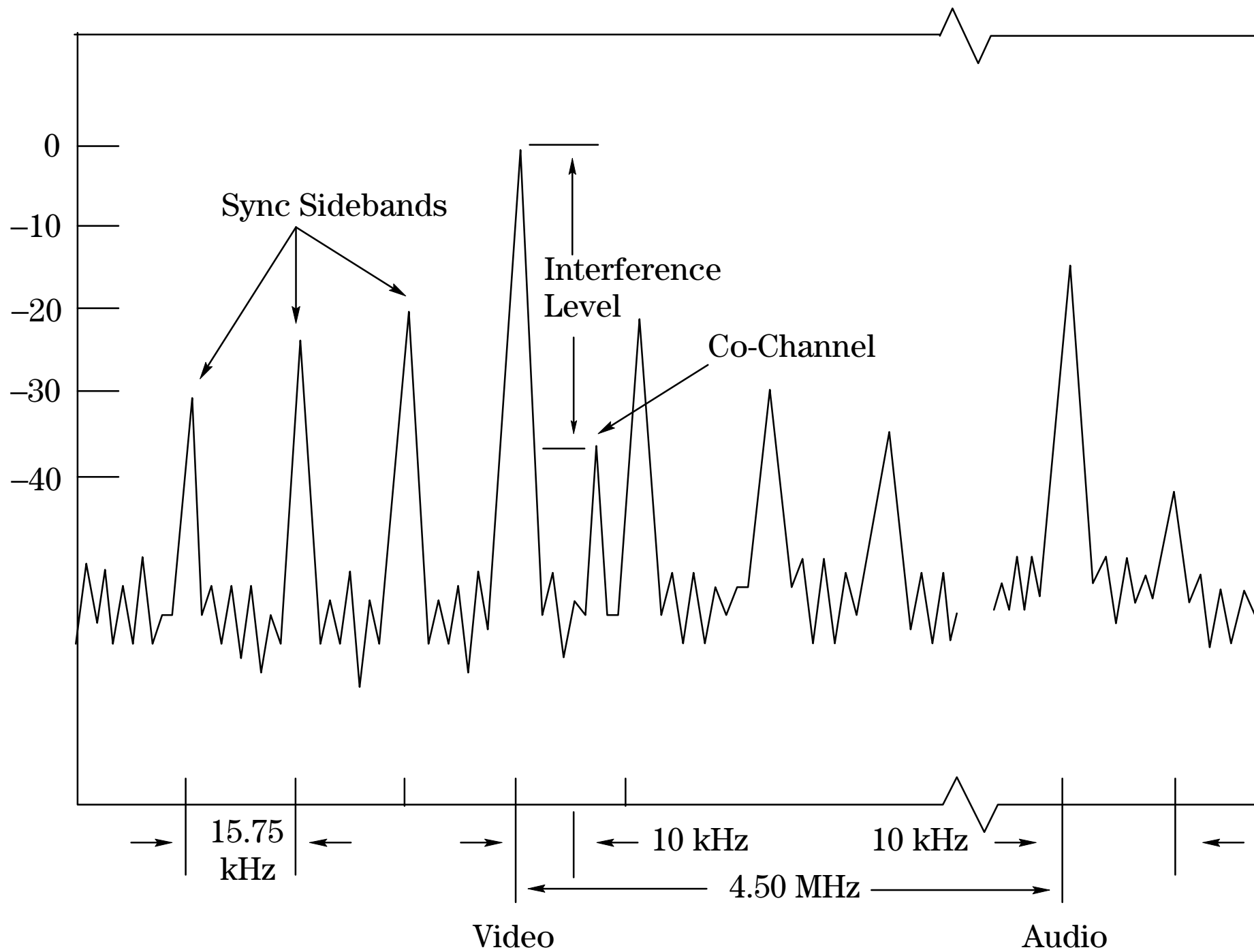
$$F_S = F_1 + \frac{F_2 - 1}{G_1} + \frac{F_3 - 1}{G_1 \times G_2} + \dots$$

$$\dots + \frac{F_n - 1}{G_1 \times G_2 \cdot \dots \cdot G_{n-1}}$$

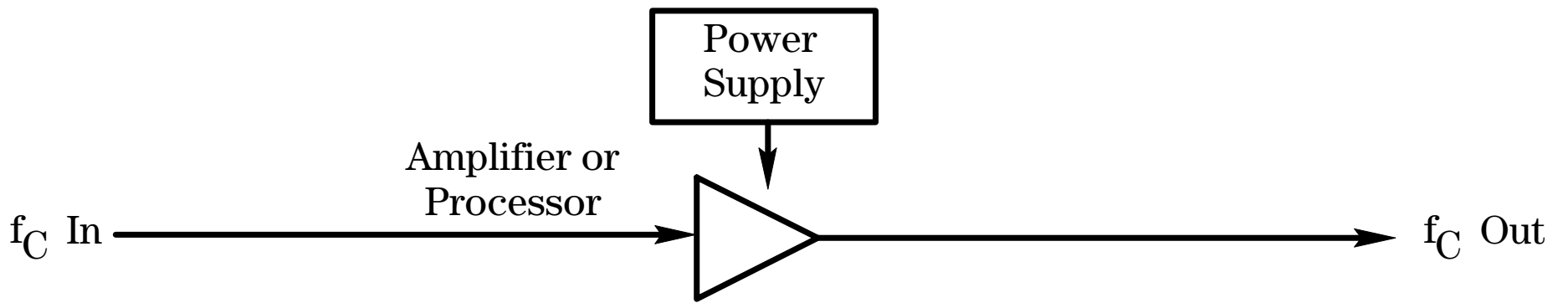
All Terms are Linear Ratios



**CO-CHANNEL INTERFERENCE**



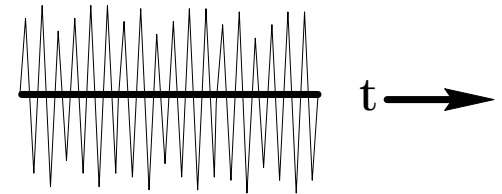
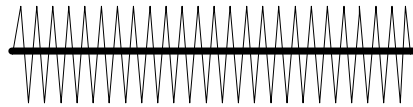




Input

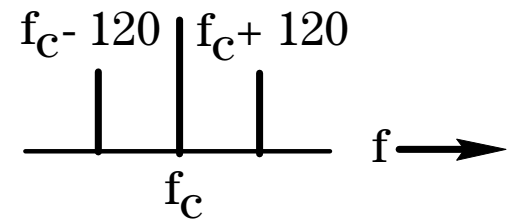
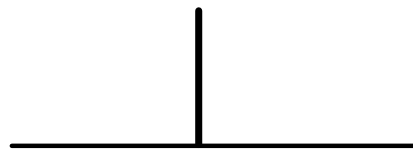
Output

Time Domain

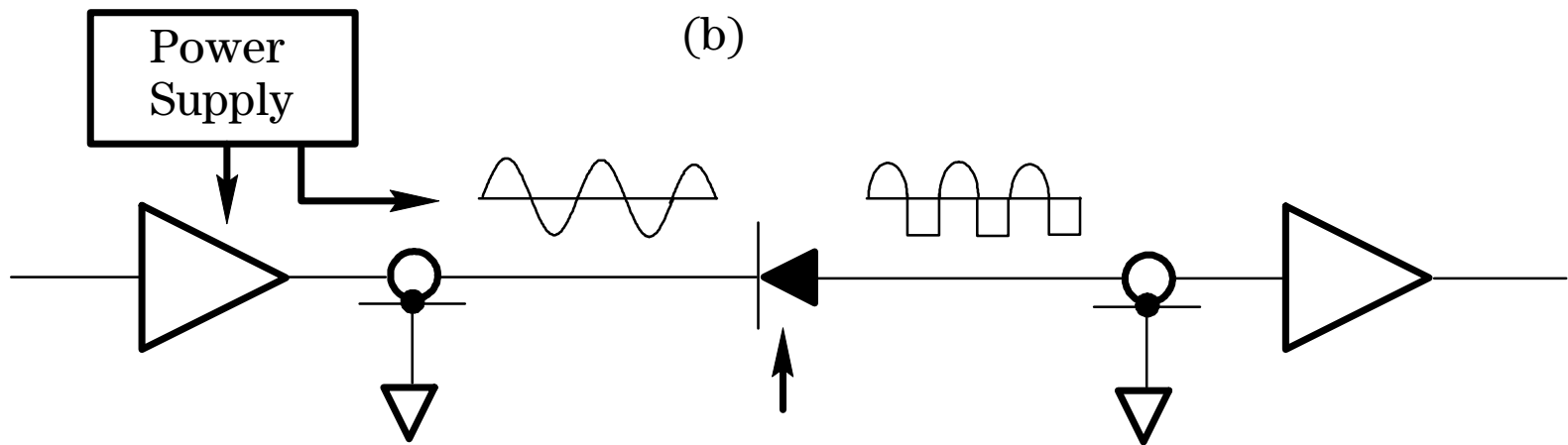


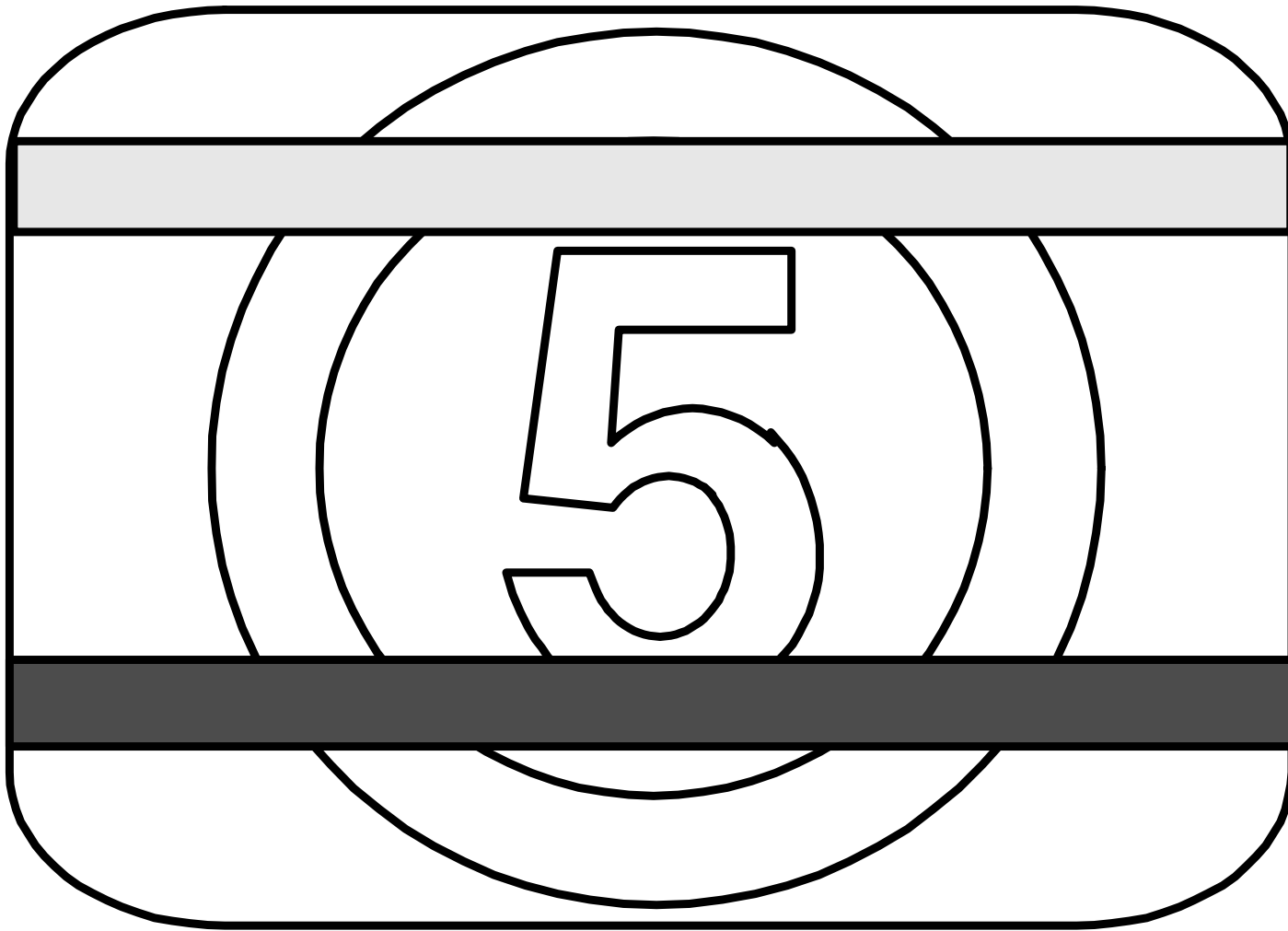
(a)

Frequency Domain



(b)

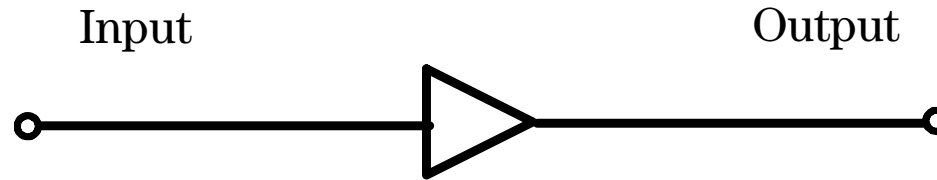




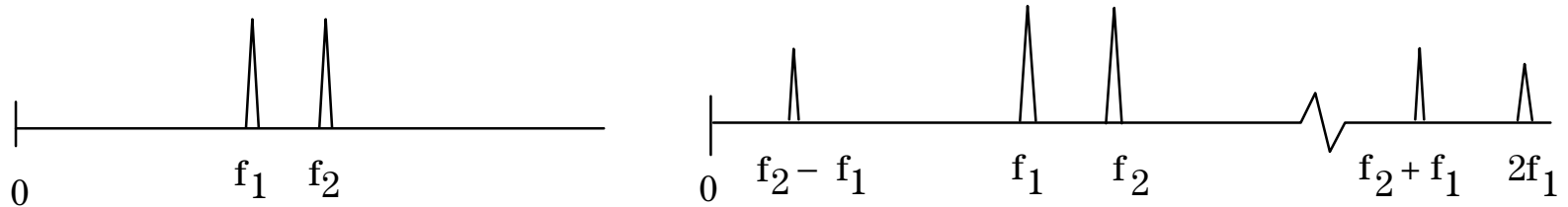
**HUM INTERFERENCE**



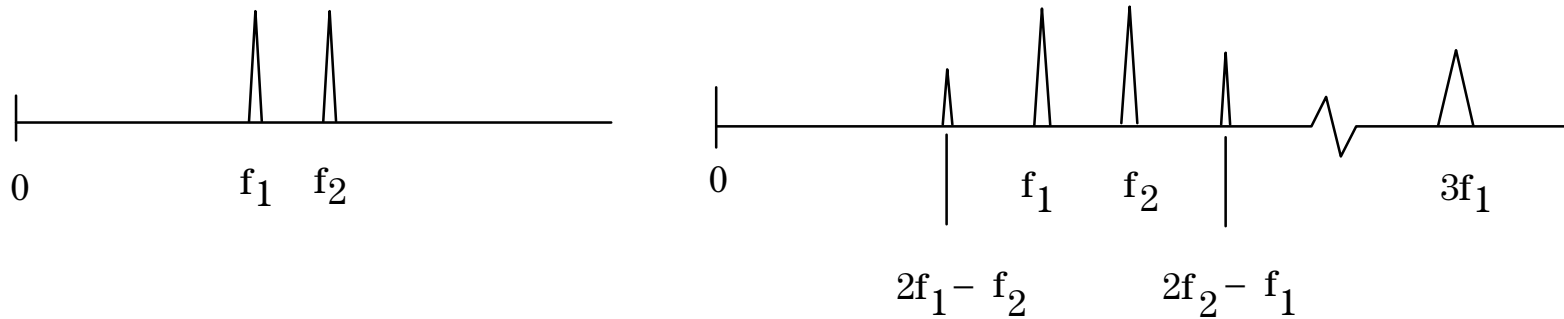
**INTERMOD CAN AFFECT  
THE RECEIVER MANY  
DIFFERENT WAYS**



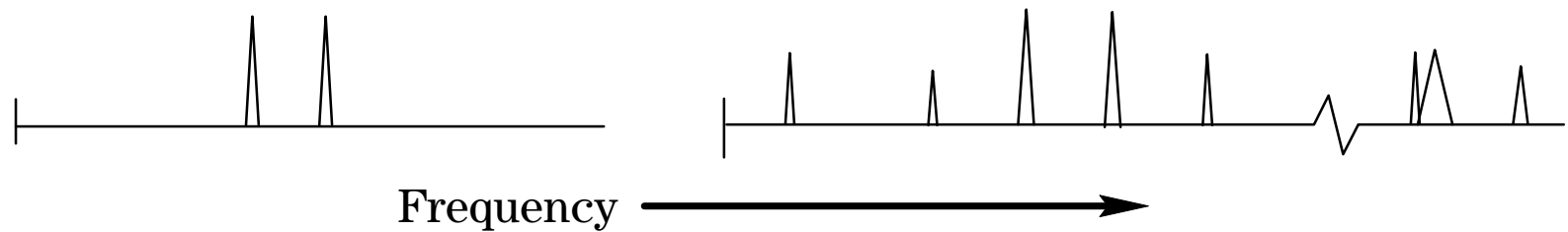
**(a) Second Order Distortion**

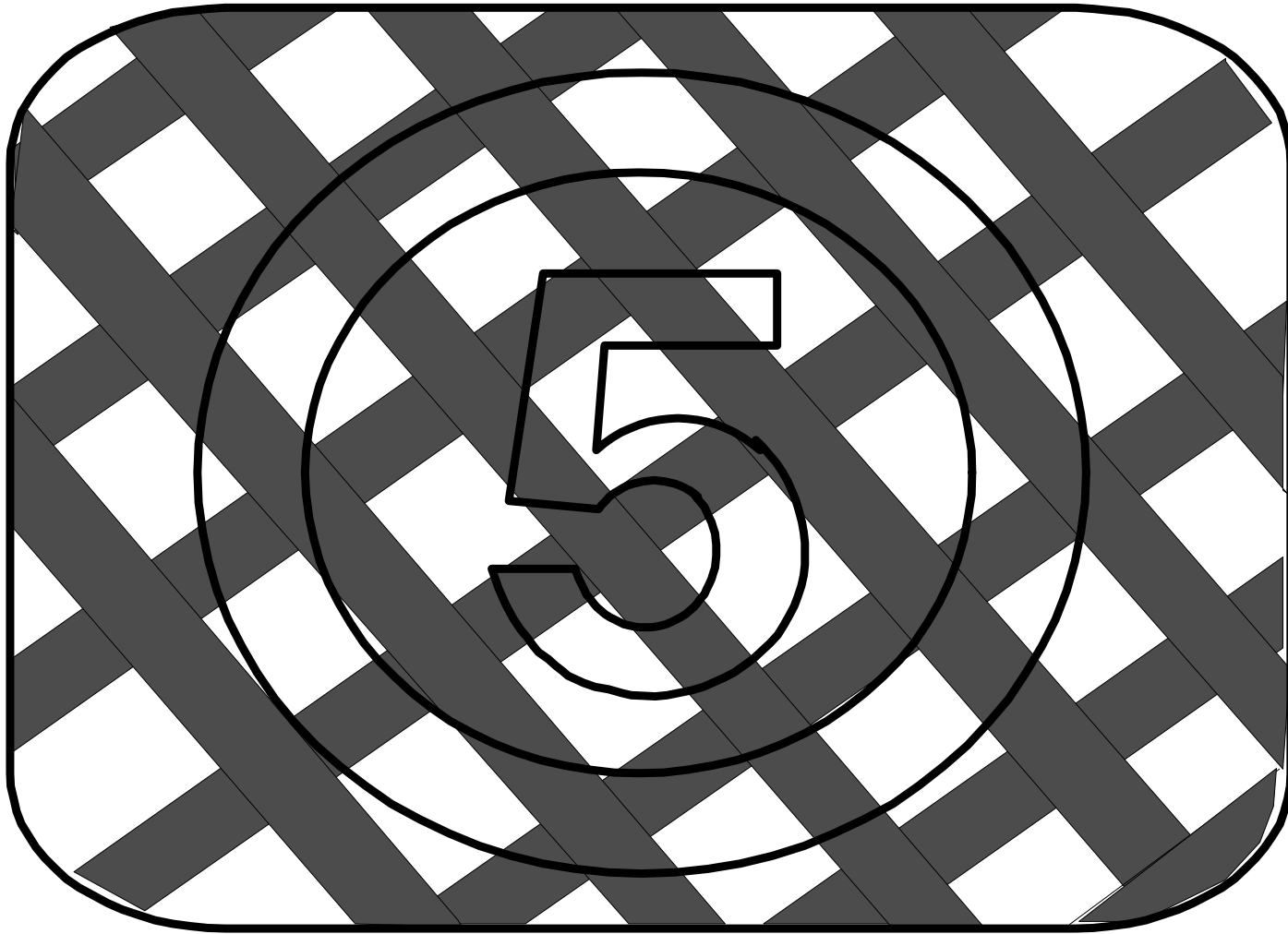


**(b) Third Order Distortion**



**(c) Composite Distortion, a) plus b)**





**CROSSMODULATION**



REF 0 dBmV

#ATTEN 0 dB

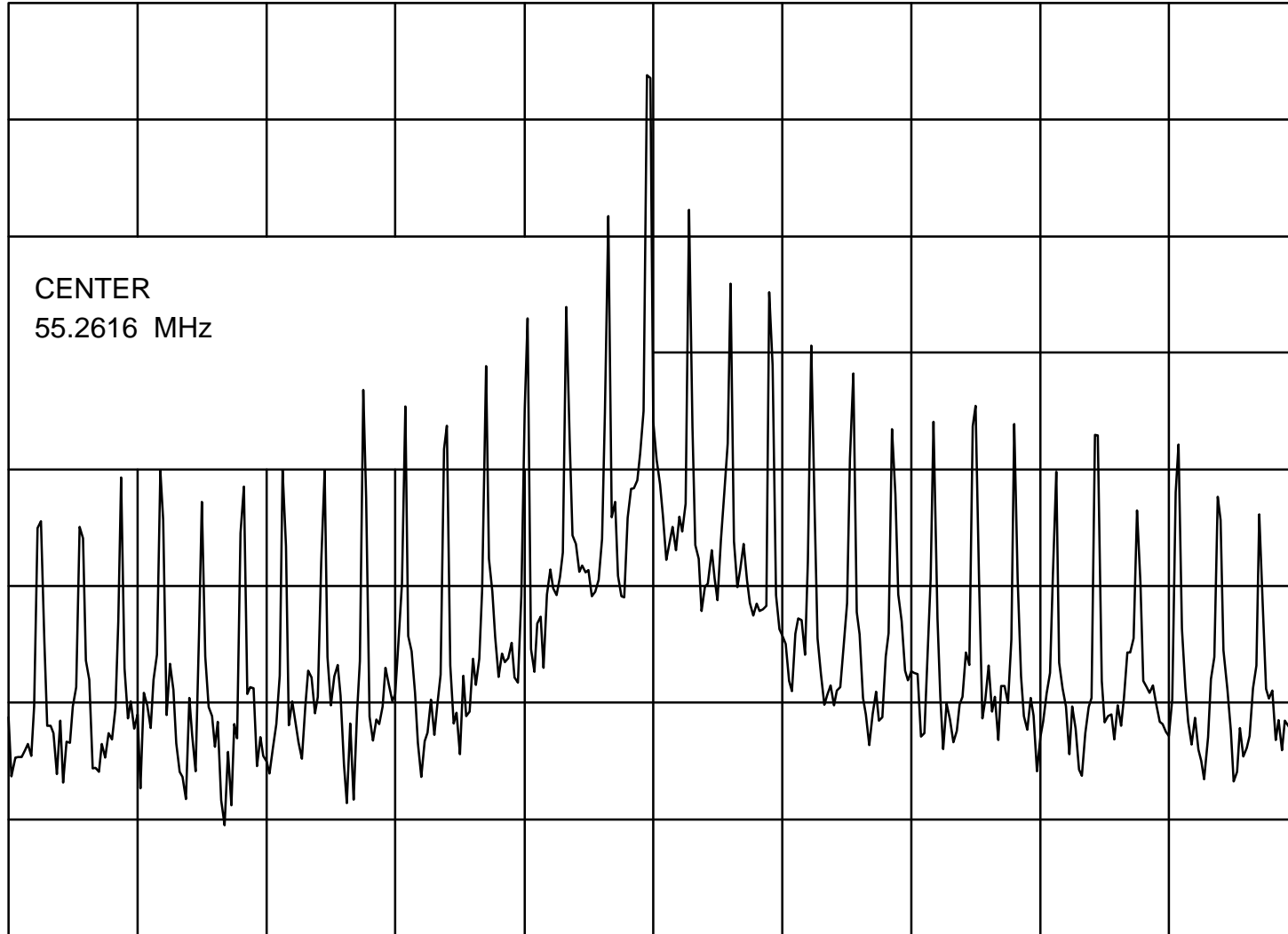
PEAK

LOG

10

dB/

CENTER  
FREQ



START  
FREQ

STOP  
FREQ

CF STEP  
AUTO MAN

FREQ  
OFFSET

Band  
Lock

WA SB  
SC FS  
CORR

CENTER 55.2616 MHz

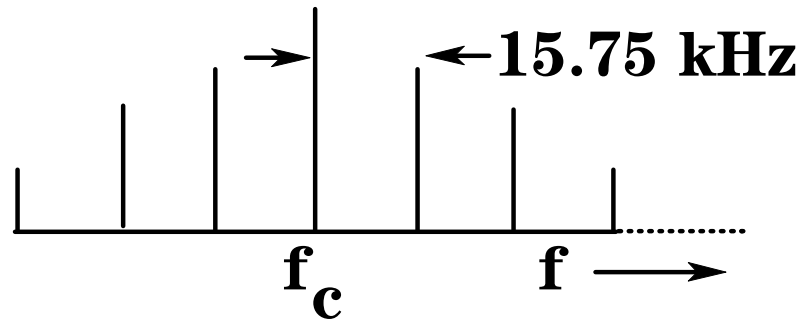
#RES BW 300 Hz

VBW 300 Hz

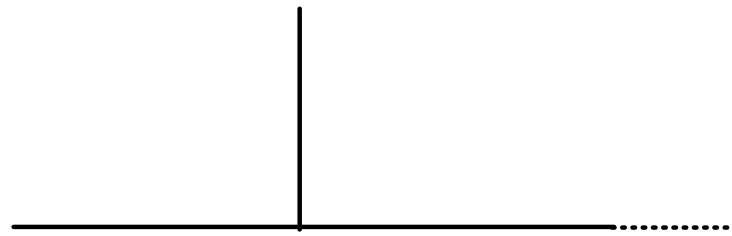
SPAN 500.0 kHz

SWP 16.7 sec

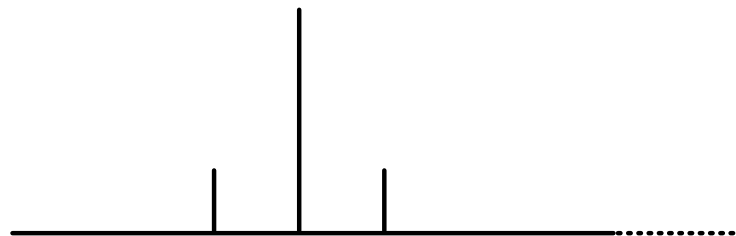
# CARRIER SPECTRUM:



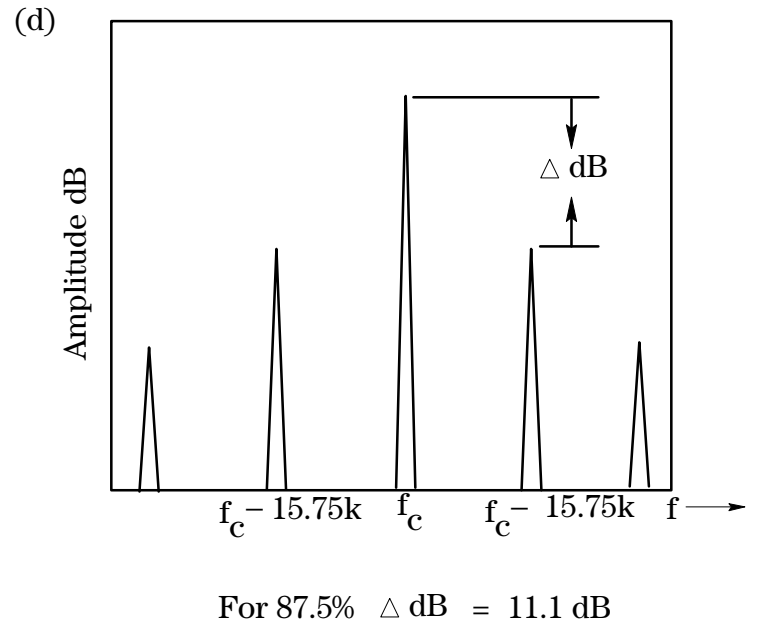
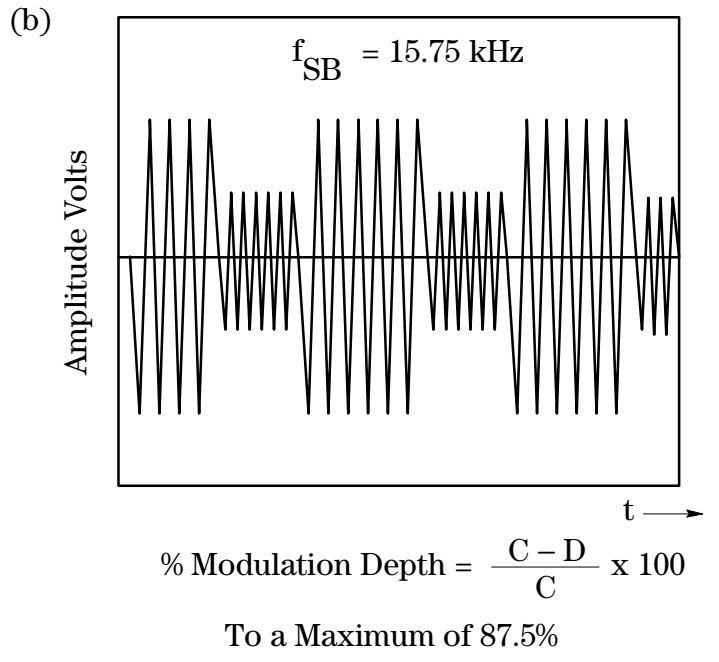
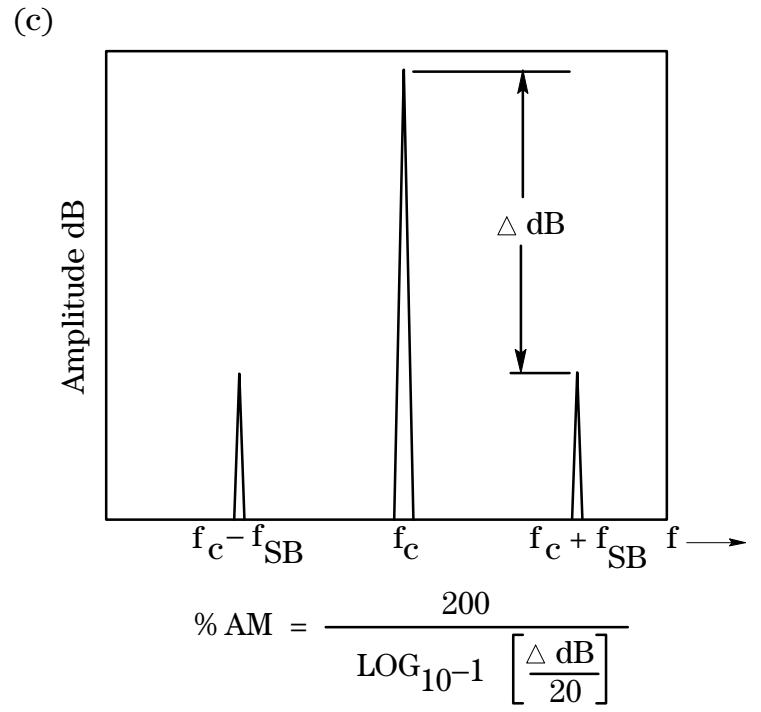
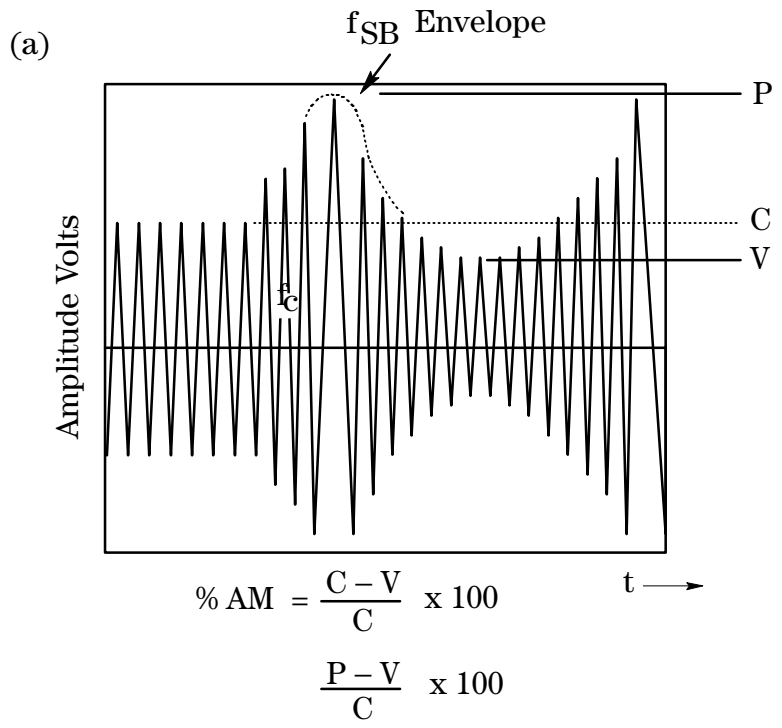
## MODULATED CARRIER



## UNMODULATED CARRIER

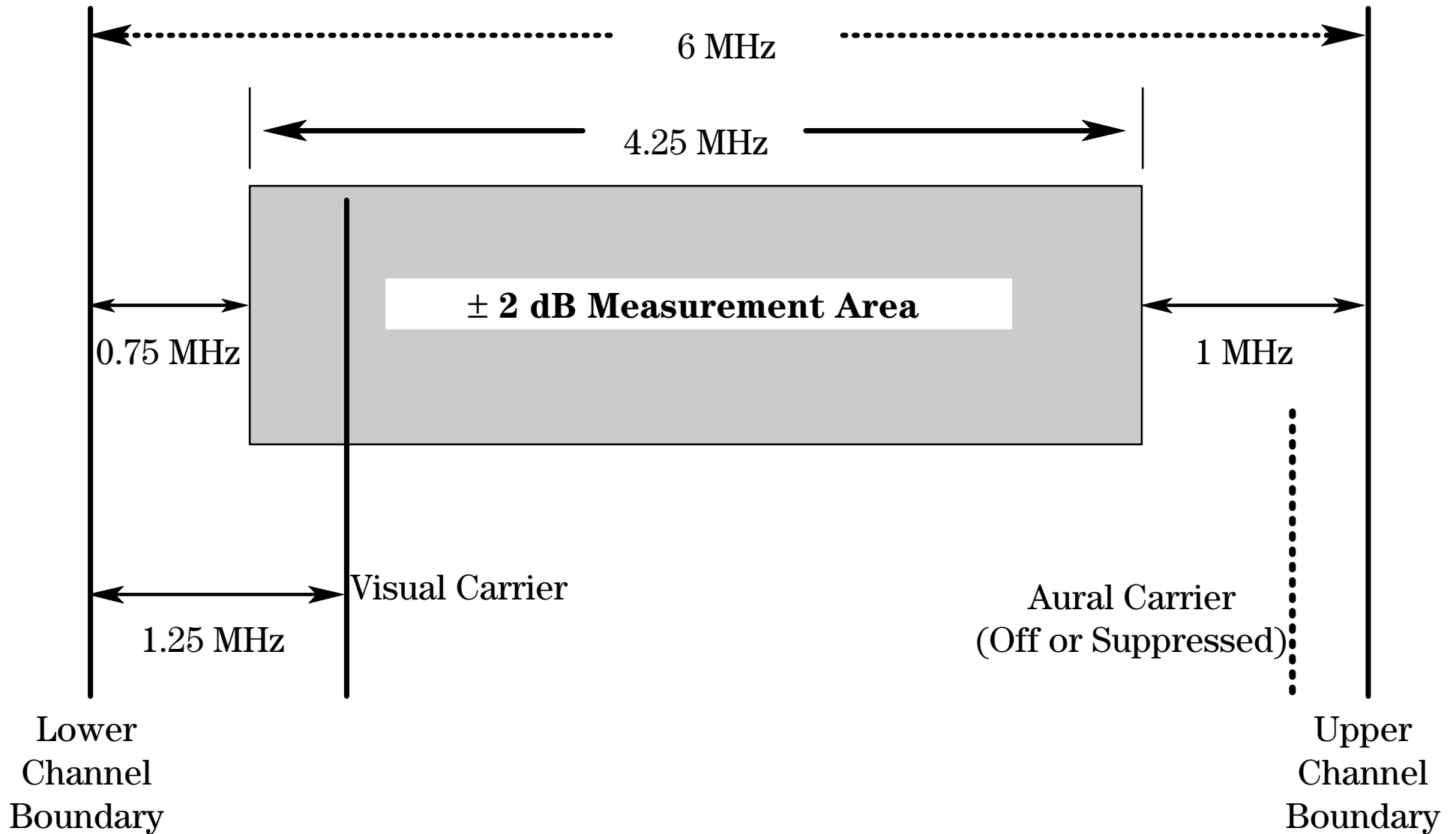


## UNMODULATED CARRIER WITH CROSMOD





# In-Channel Frequency Response Measurement Area for a Cable TV Channel



CHANNEL 2 (STD)

REF 33.19 mV

#ATTEN 10 dB

MKR 7.2000  $\mu$ sec

CATV

SMPL  
LIN

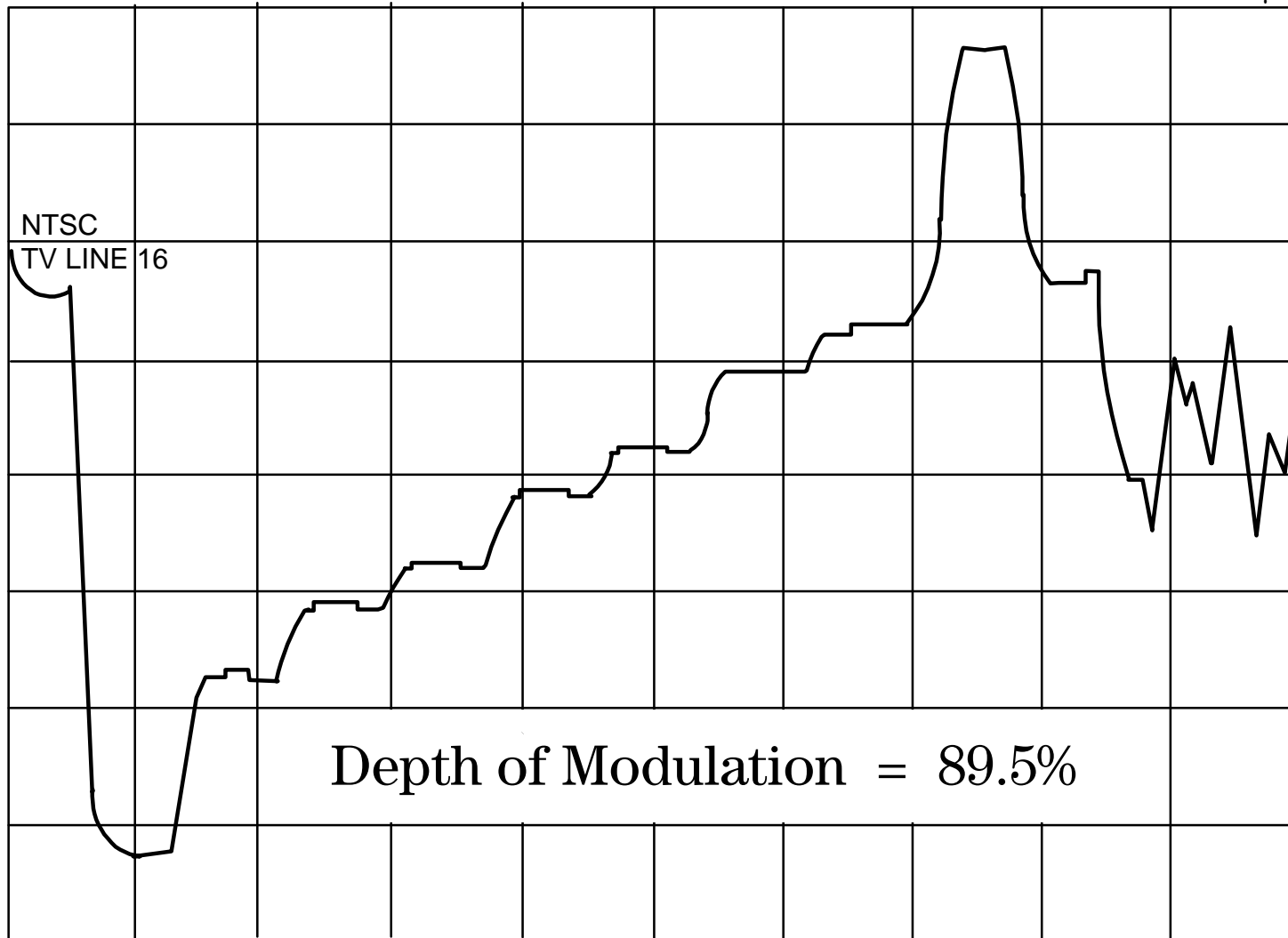
3.3565  $\mu$ V

TV  
LINE #

TV TRIG  
ODD FLO

TV TRIG  
EVEN FLO

TV TRIG  
VERT INT



WA SB  
SC TC  
CORR

CENTER 55.290 MHz

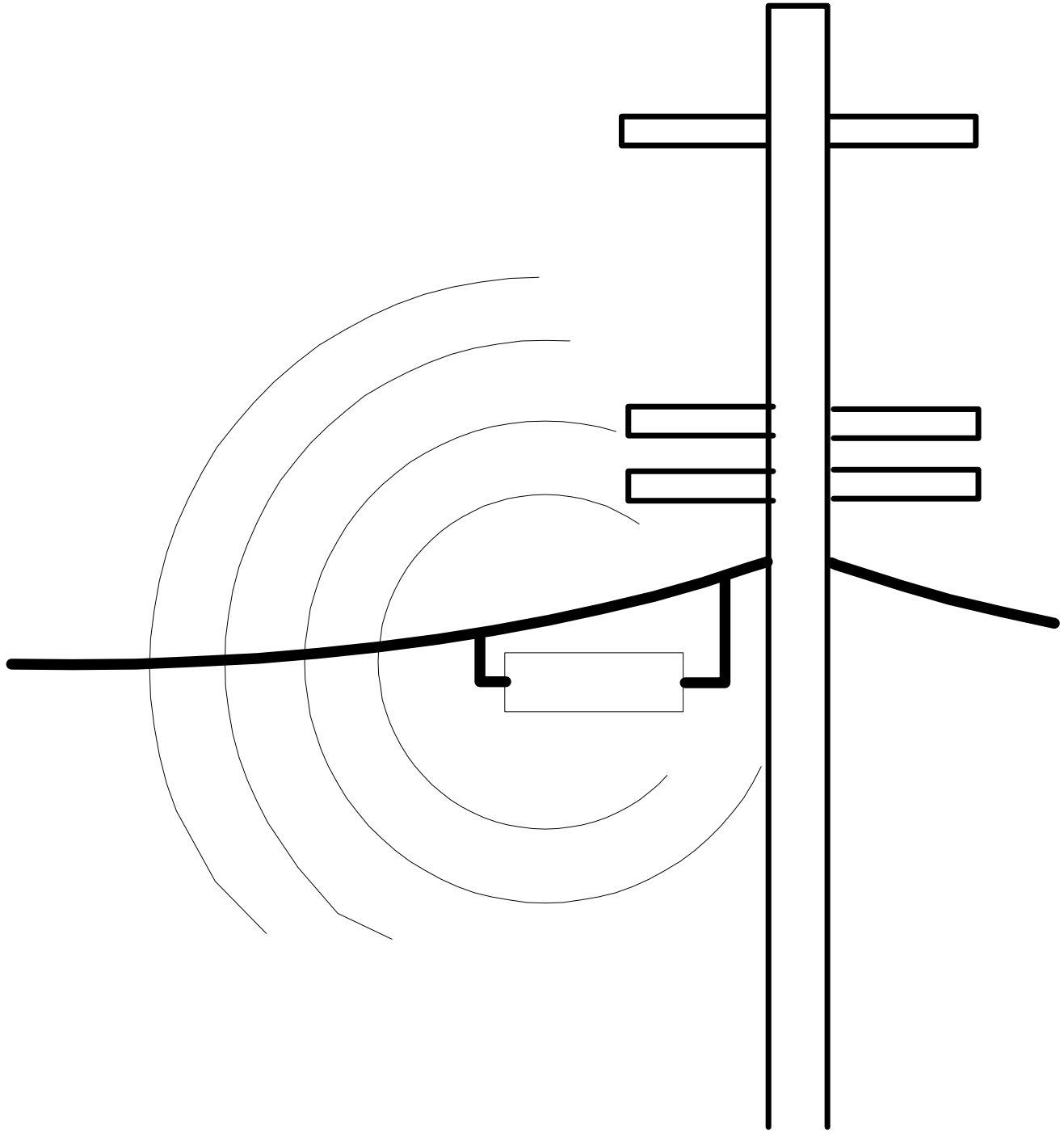
#RES BW 1.0 MHz

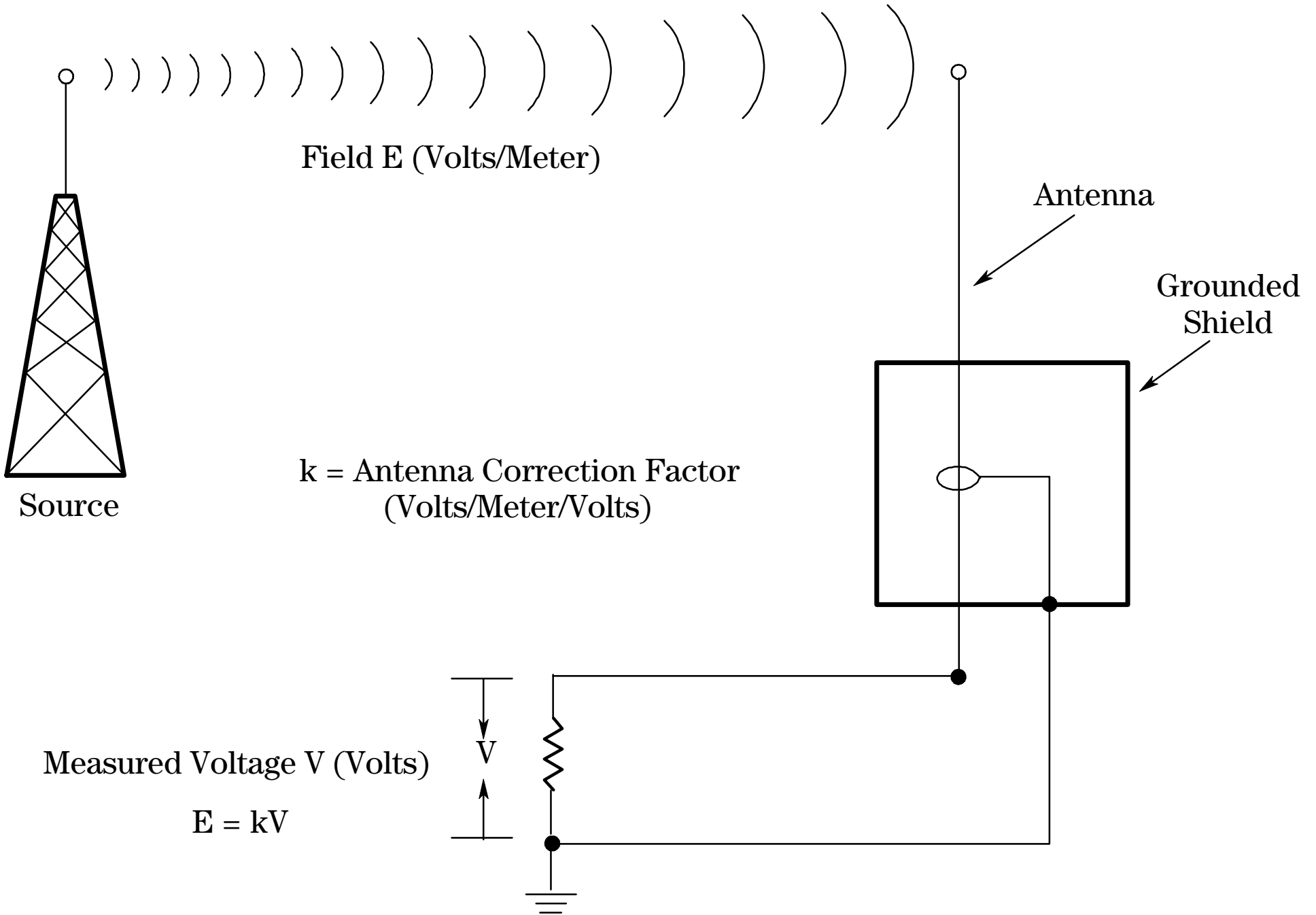
#VBW 300 kHz

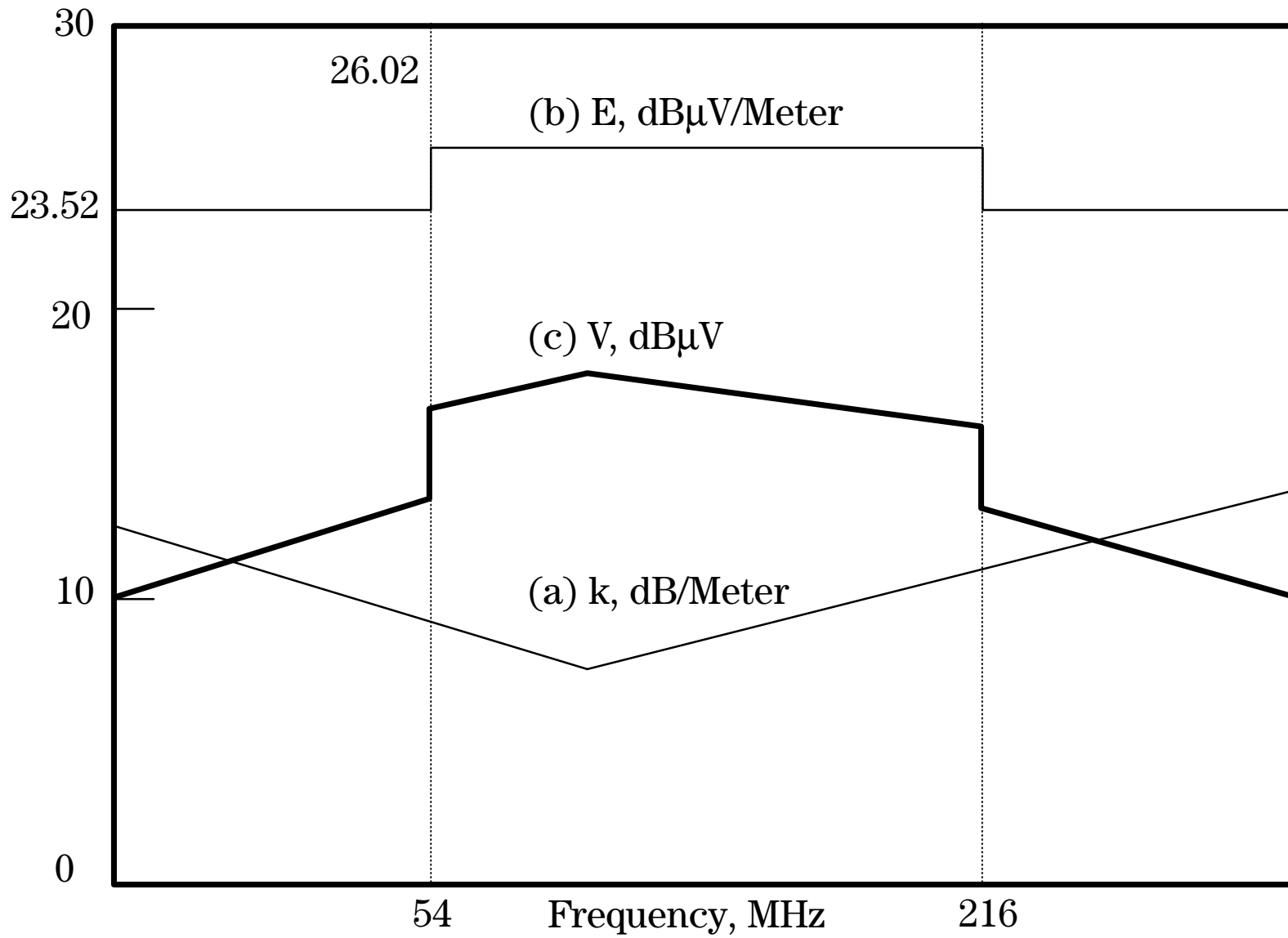
SPAN 0 Hz

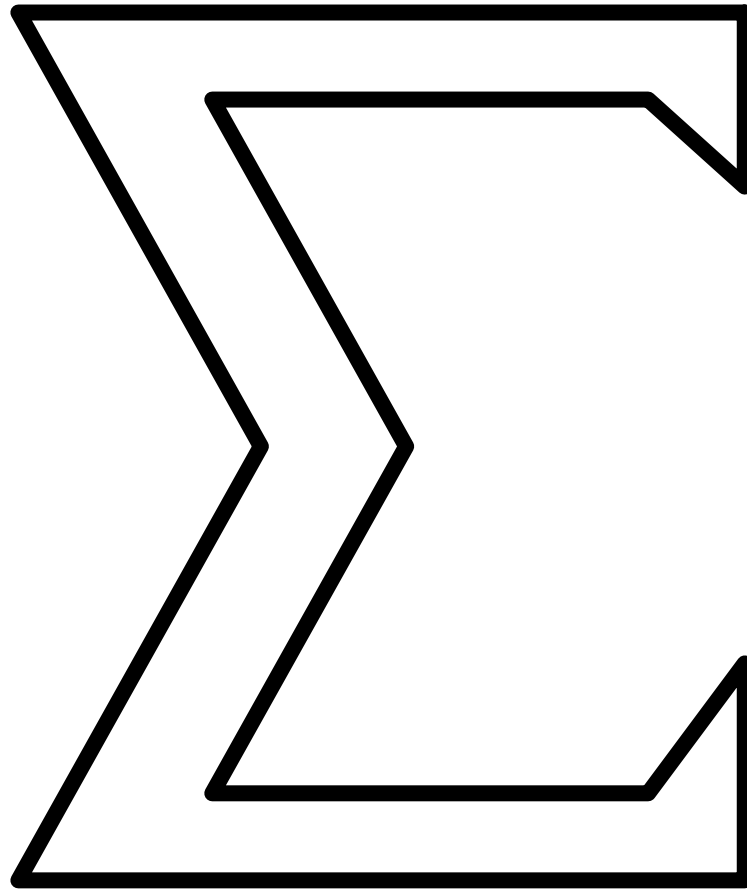
SWP 80  $\mu$ sec

Prev  
Menu  
L



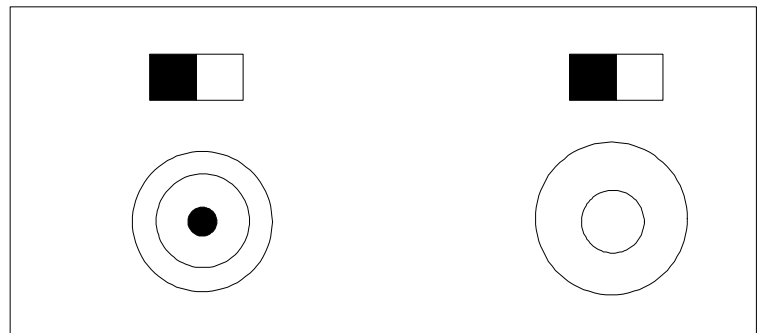
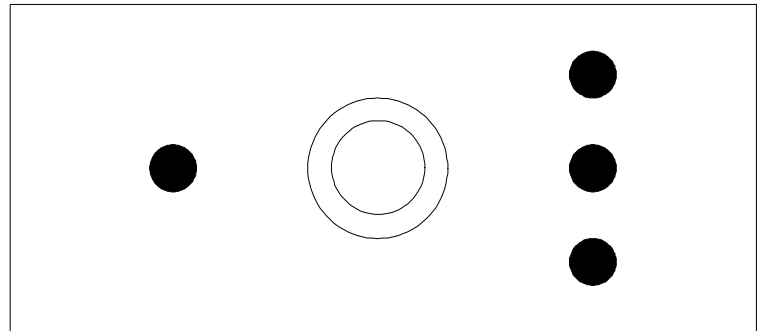
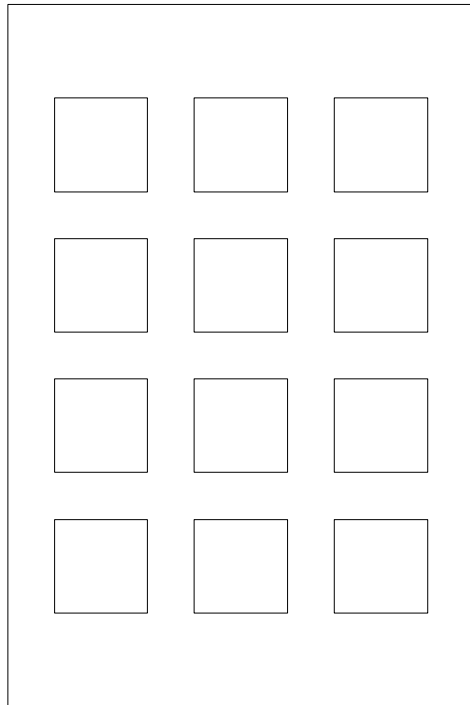
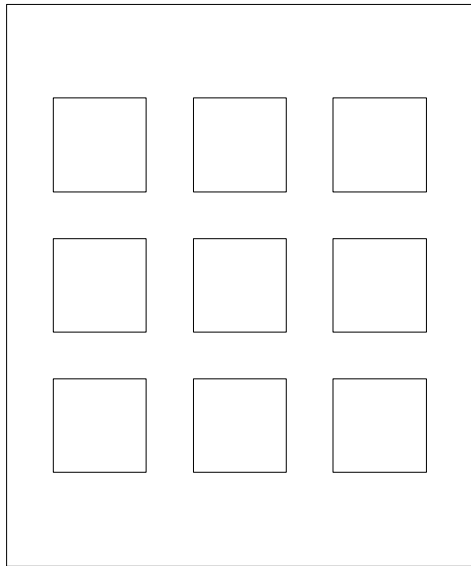


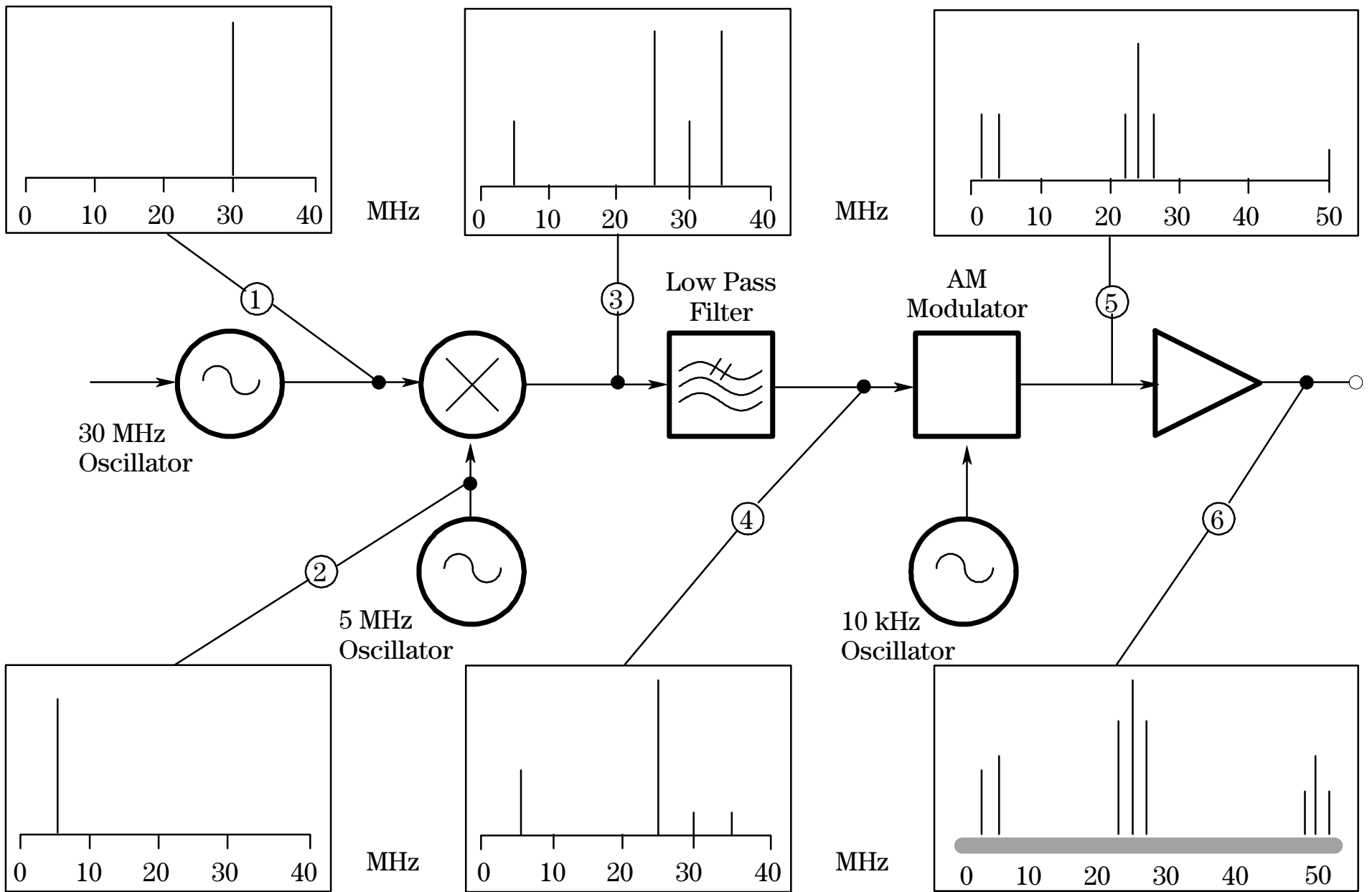




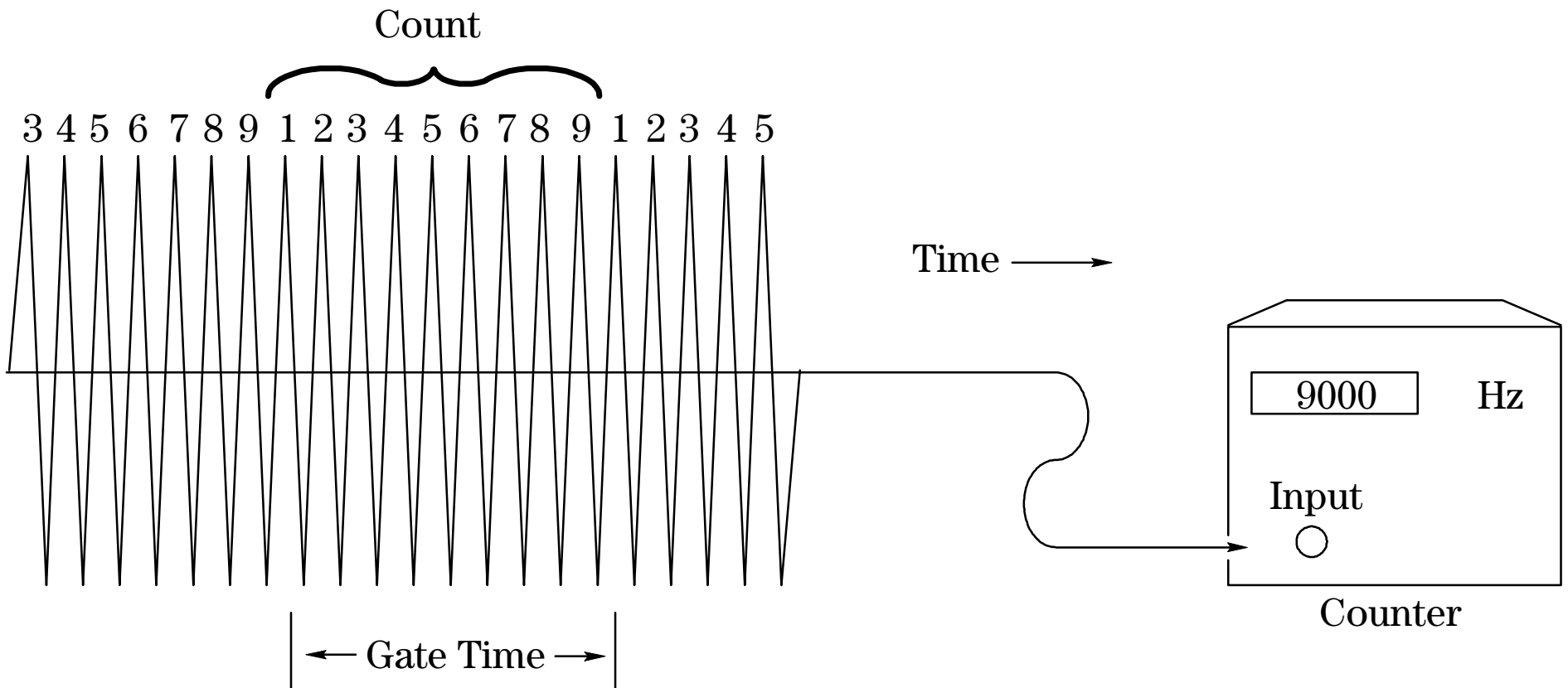
**PARAMETERS**

26 866 205 377

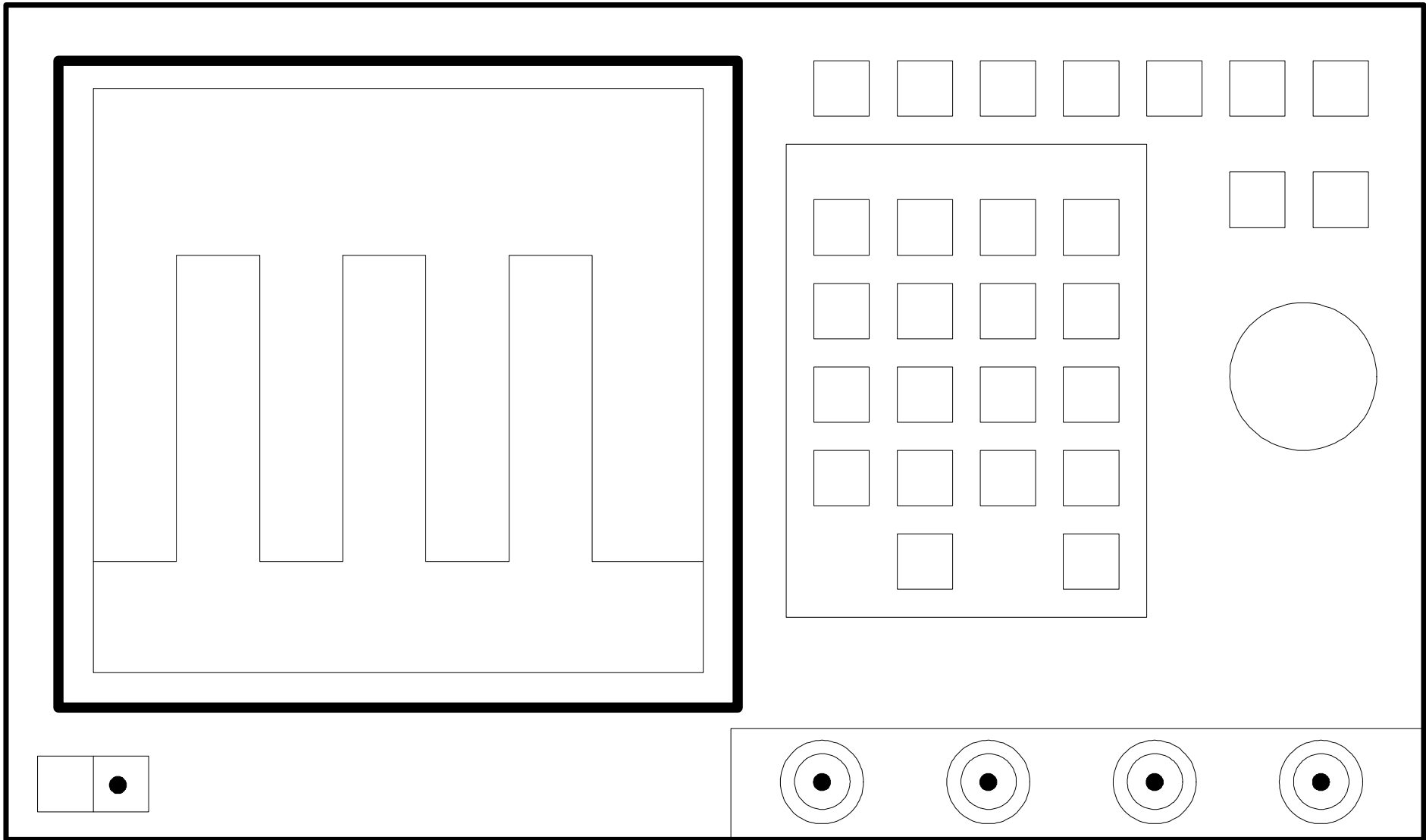




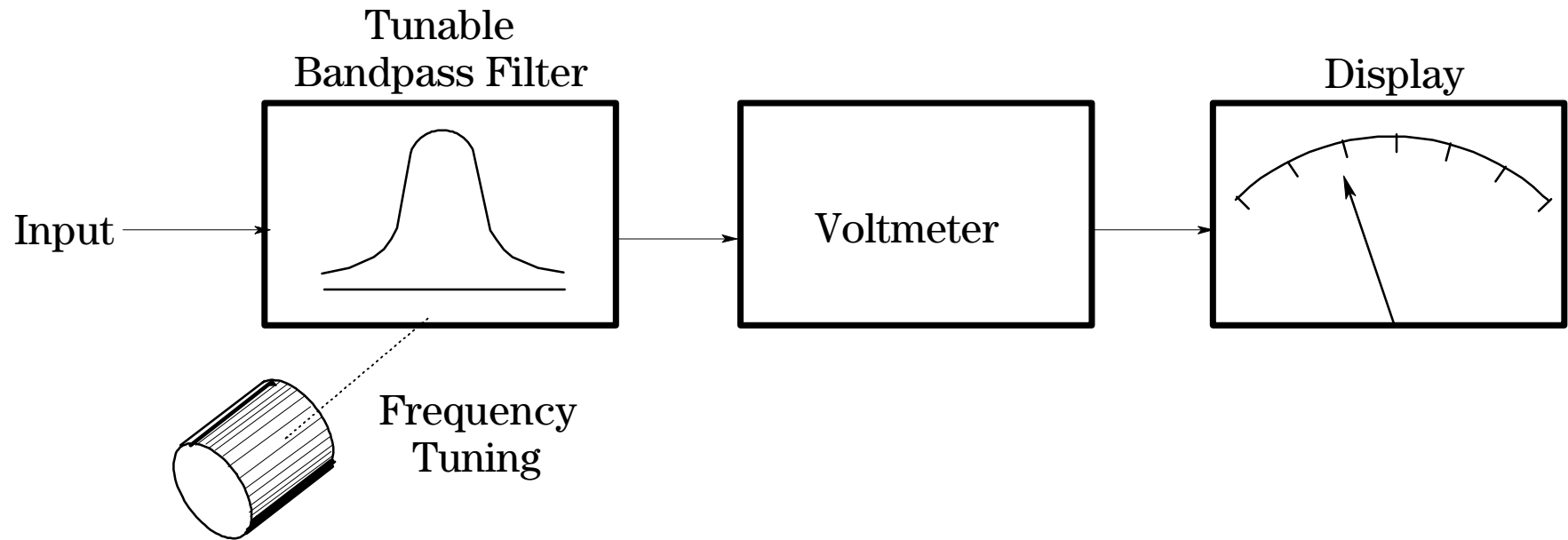




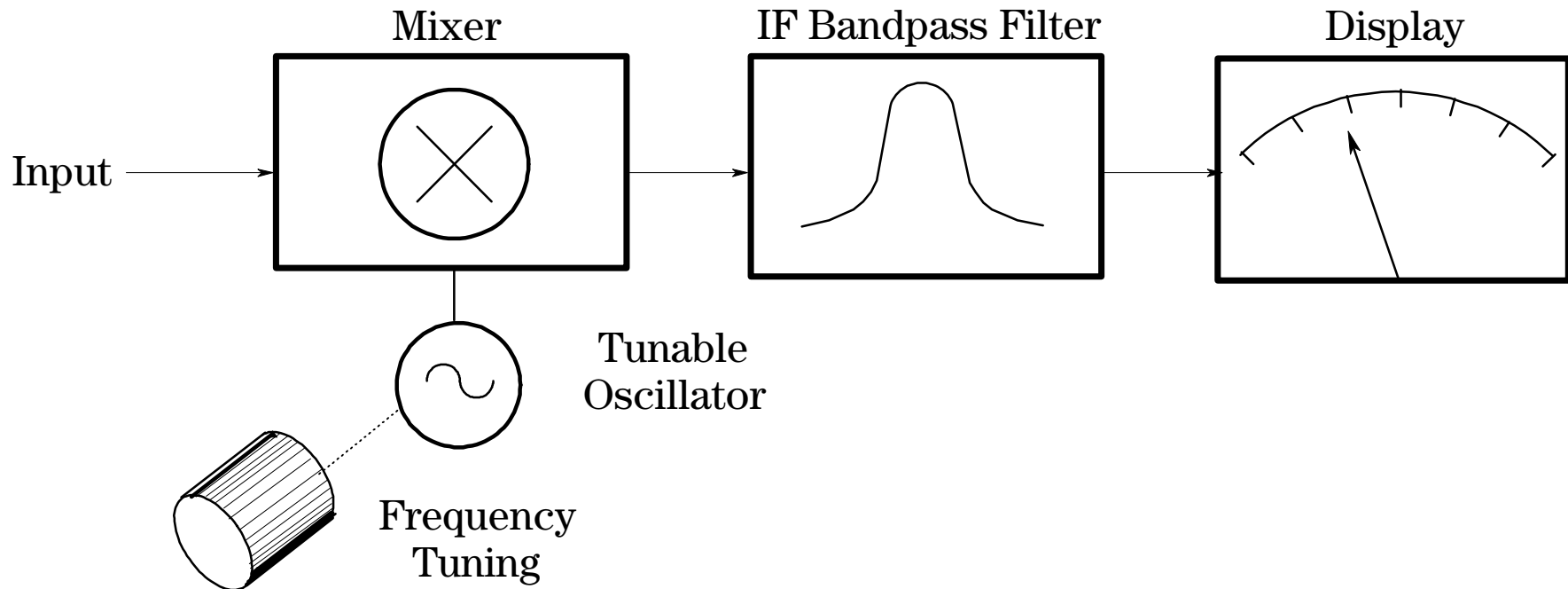
$$\text{Counter Frequency Reading} = \frac{\text{Count}}{\text{Gate Time}}$$

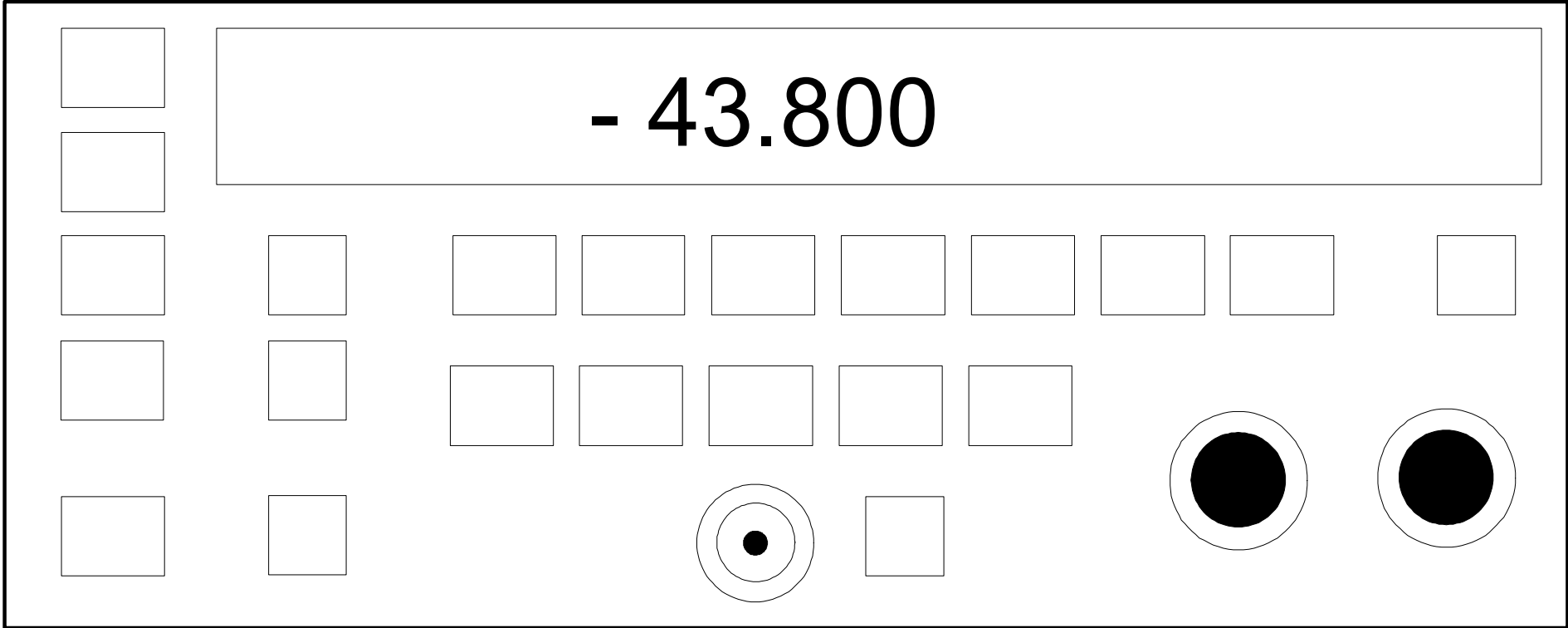


### (a) Tuned Voltmeter

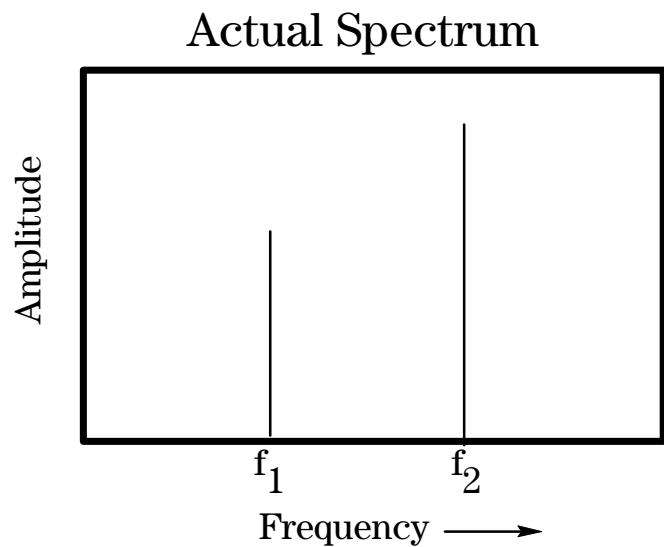


### (b) Field Strength Meter

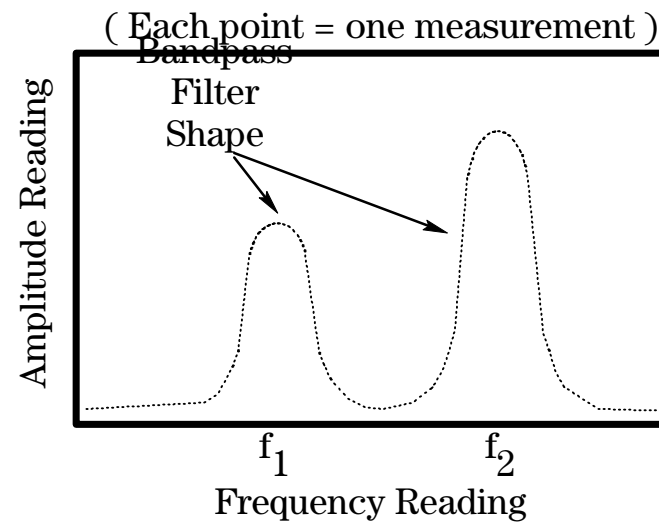




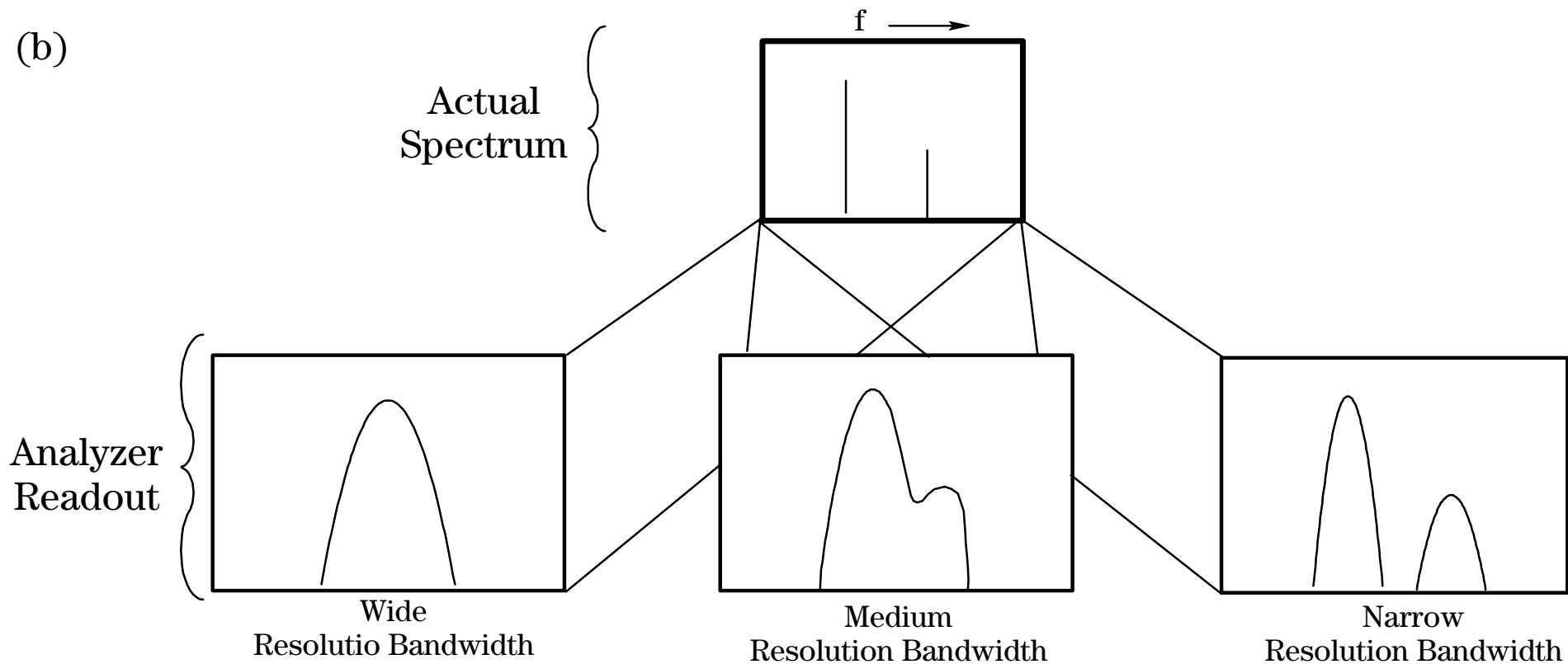
(a)



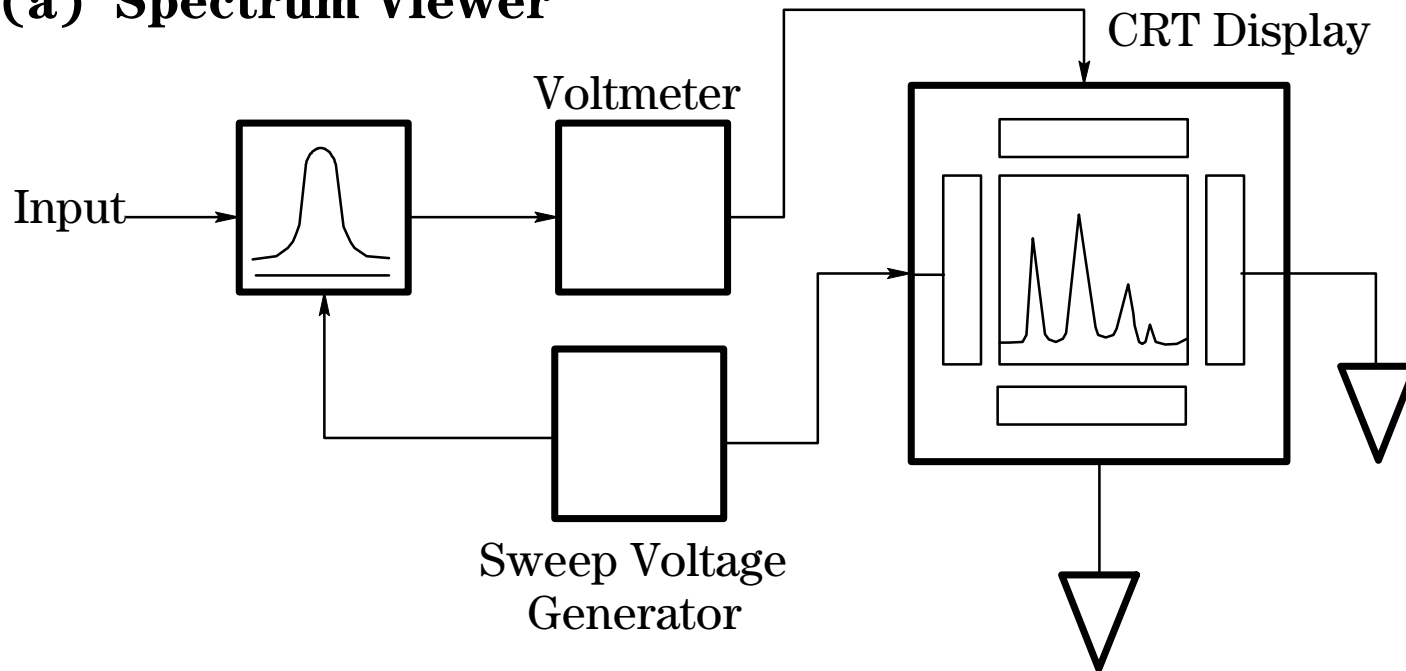
### Spectrum Analyzer Readouts



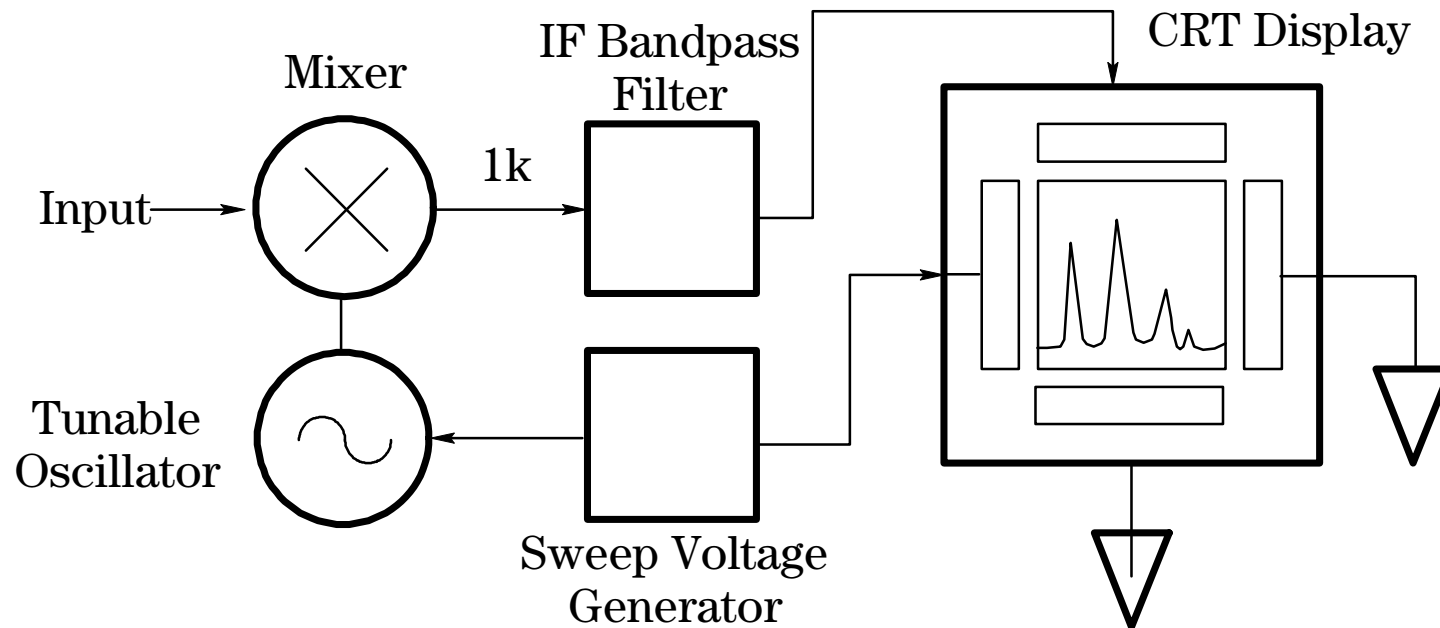
(b)

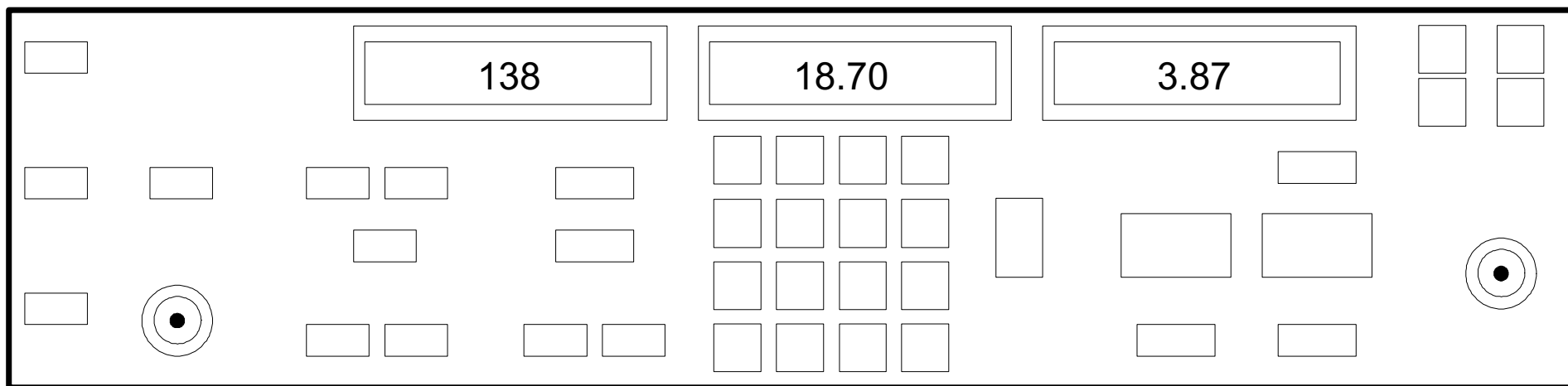


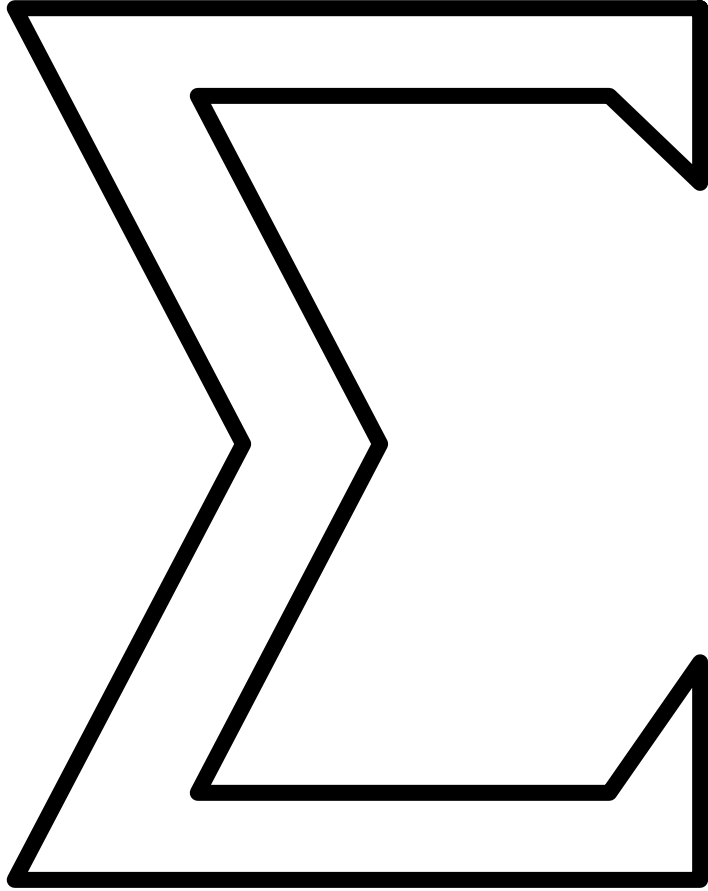
### (a) Spectrum Viewer



### (b) Spectrum Analyzer



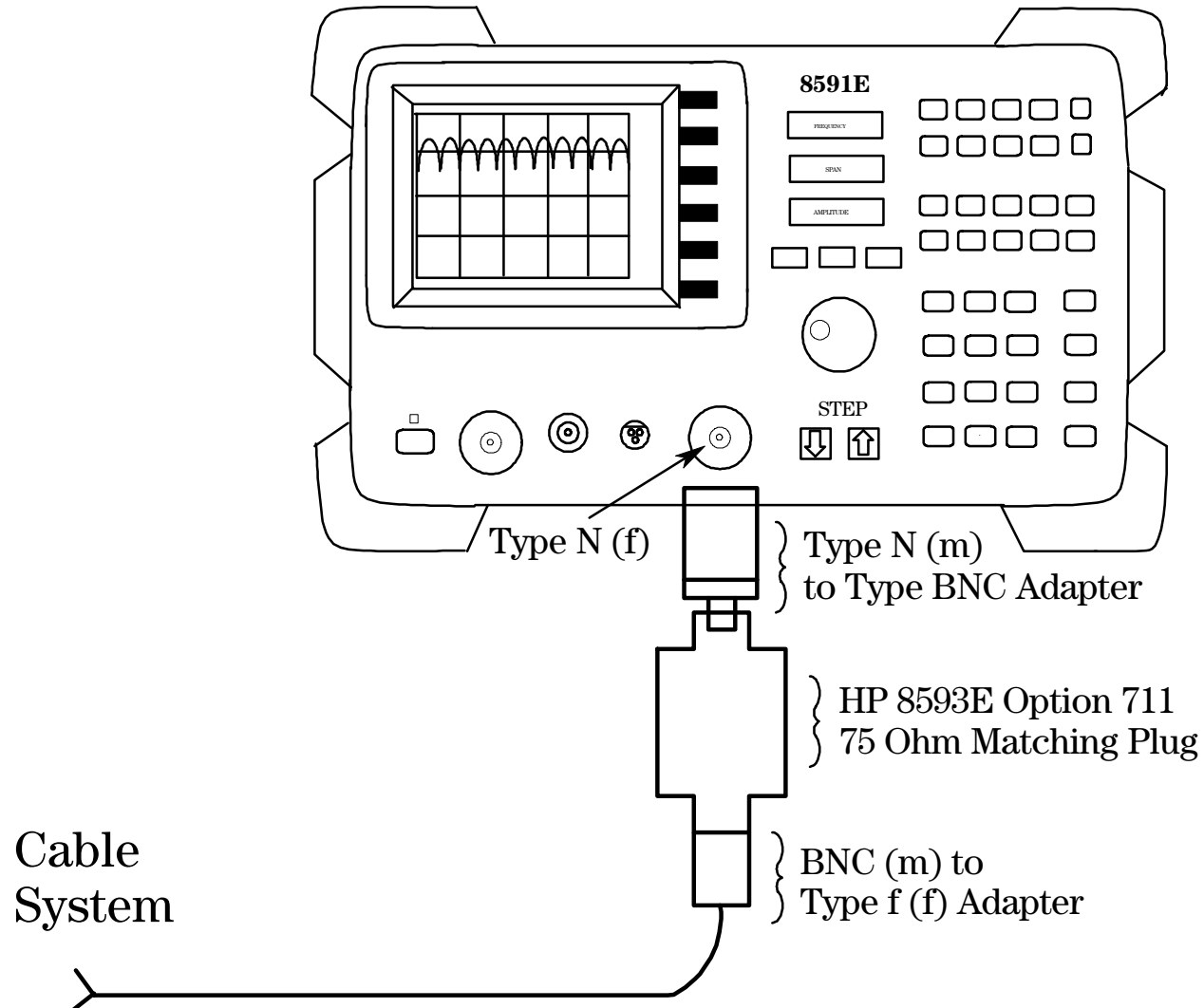




**Instruments**



# Impedance Matching 50Ω Microwave Spectrum Analyzer



hp

# Commerical FM Band

REF 12.0 dBmV

#ATTEN 0 dB

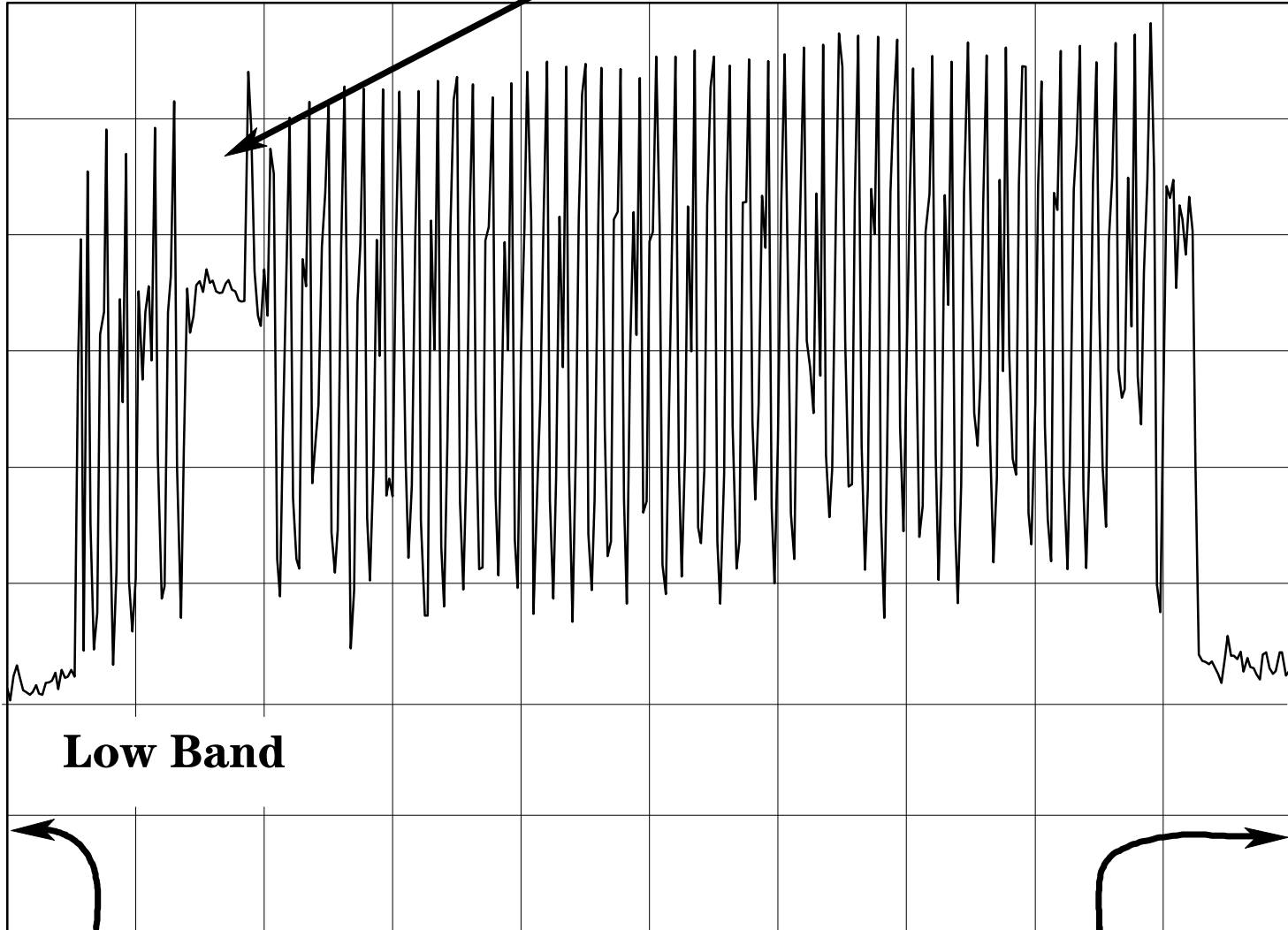
PEAK

LOG

10

dB/

VA SB  
SC FC  
CORR



START 30.0 MHz

#RES BW 100 kHz

#VBW 30 kHz

STOP 450.0 MHz

SWP 420 msec

hp

CNTR  $\Delta$  4.49999 MHz

REF -24.0 dBm

ATTEN 10 dB

-8.52 dB

PEAK

LOG

10

dB/

COUNTER  $\Delta$   
4.49999 MHz  
-8.52 dB

WA SB  
SC FC  
CORR

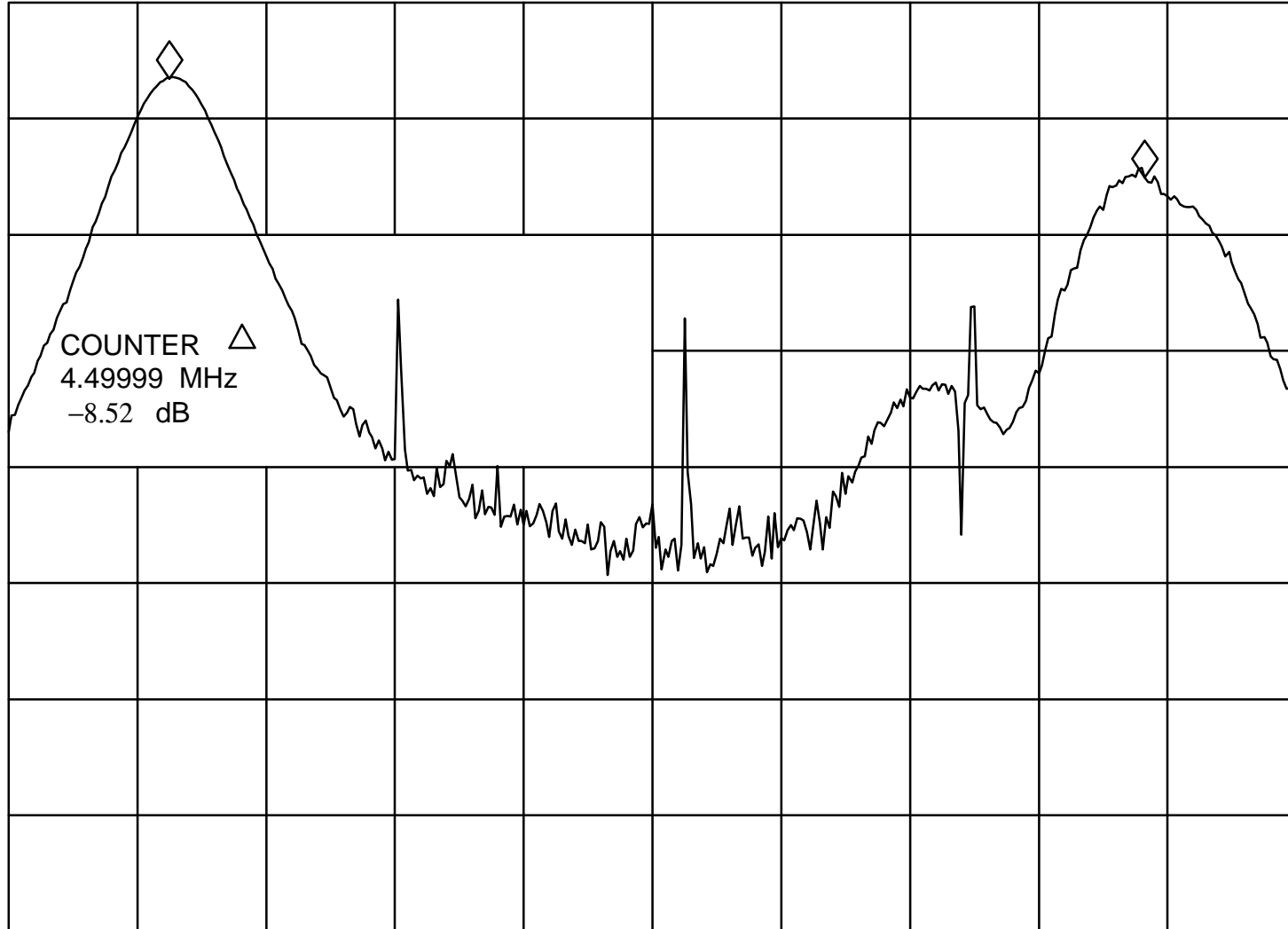
CENTER 69.511 MHz

#RES BW 300 kHz

#VBW 300 kHz

SPAN 6.000 MHz

SWP 75.0 msec





REF 2.0 dBmV

ATTEN 10 dB

MKR  $\Delta$  3.5 kHz  
-14.59 dB

PEAK

LOG

10

dB/

MARKER  
NORMAL

MARKER



MARKER  
AMPTD

MARKER  $\Delta$   
3.5 kHz  
-14.59 dB

SELECT  
1 2 3 4

WA SB  
SC FS  
CORR

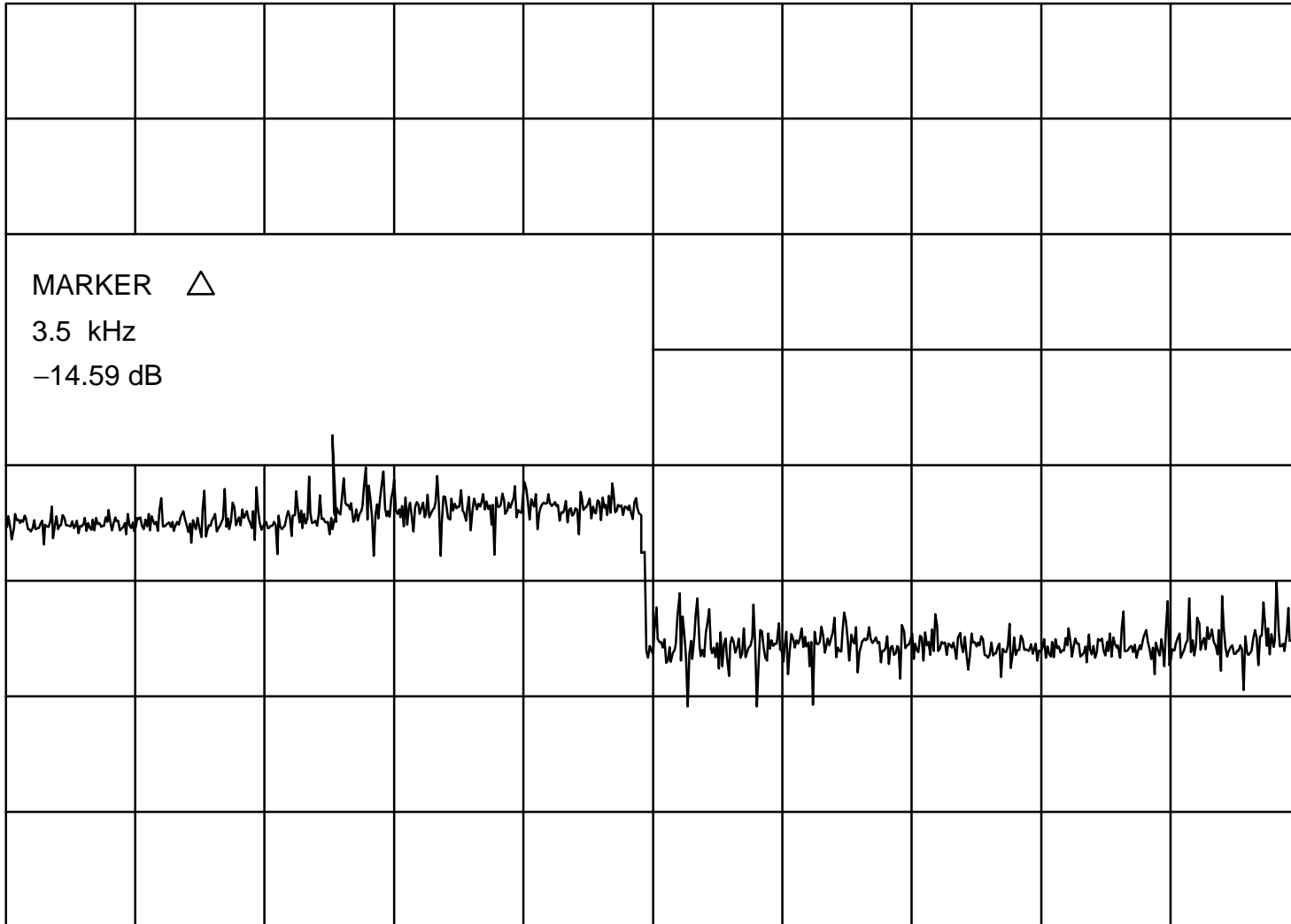
MARKER 1  
ON OFF

More  
1 of 2

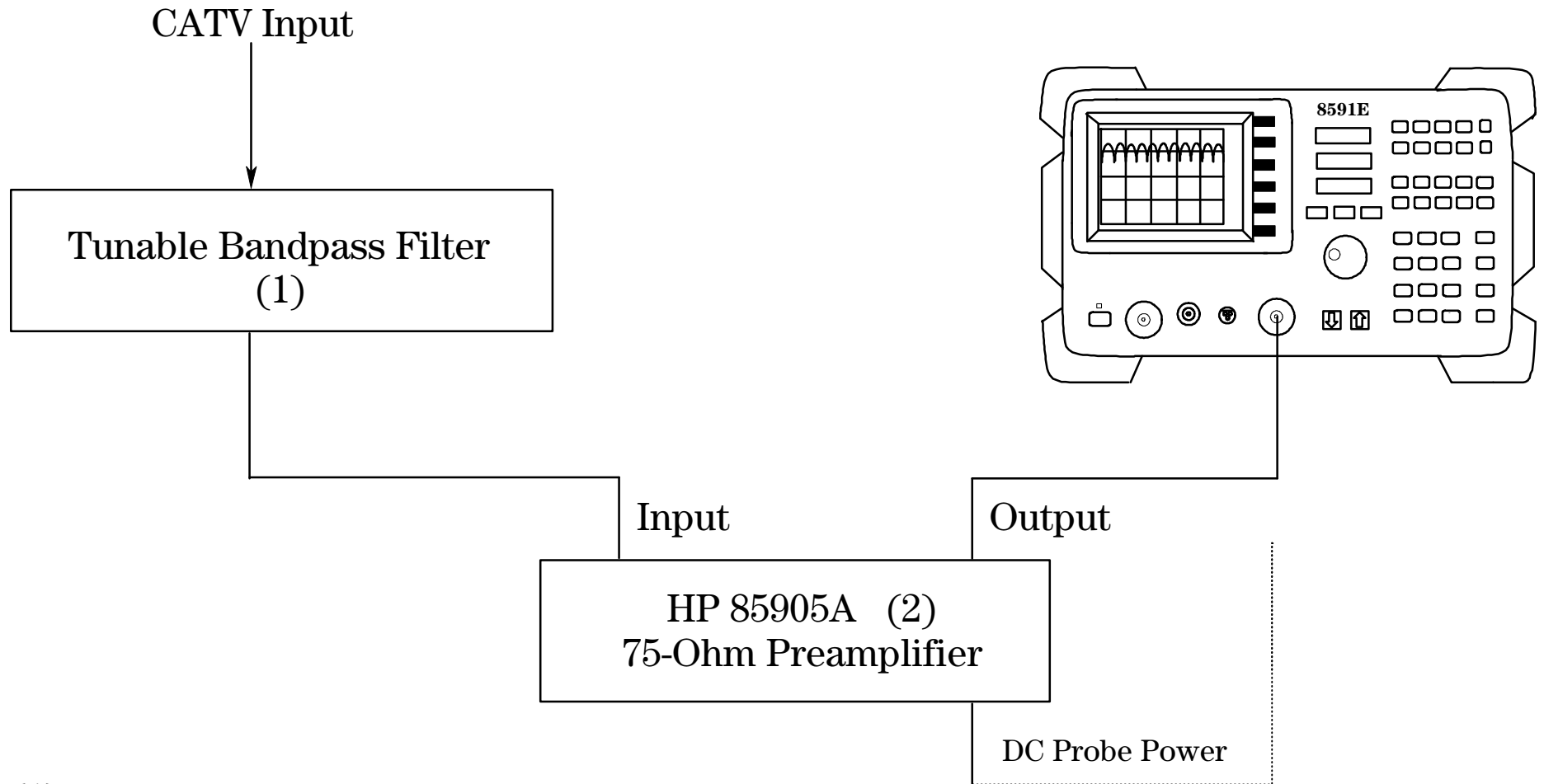
CENTER 52.9470 MHz  
RES BW 3.0 kHz

#VBW 300 kHz

SPAN 200.0 kHz  
#SWP 2.00 sec



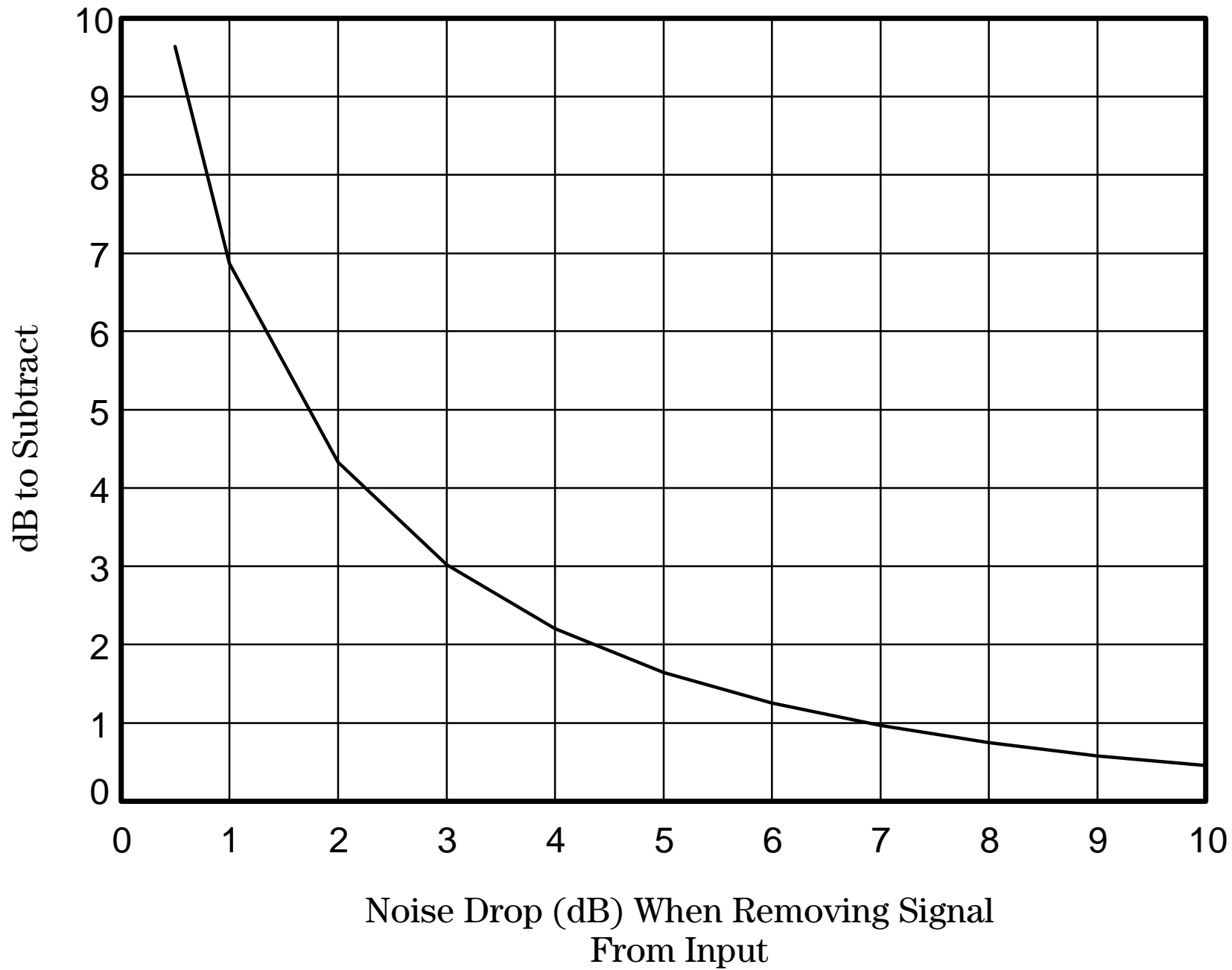
# Setup for Carrier-to-Noise Measurement



(1) Required when analyzer is in compression

Total power = carrier power (dBmV) + 10 log (number of channels)

(2) Required when carrier levels are < + 15 dBmV



hp

REF 27.0 dBmV

#ATTEN 10 dB

MKR 54.848 MHz  
-70.55 dBmV (1 Hz)

SMPL

LOG

10

dB/

MARKER  
54.848 MHz  
-70.55 dBmV (1 Hz)

MK TRACK  
ON OFF

MK COUNT  
ON OFF

MK TABLE  
ON OFF

MK NOISE  
ON OFF

MK PAUSE  
ON OFF

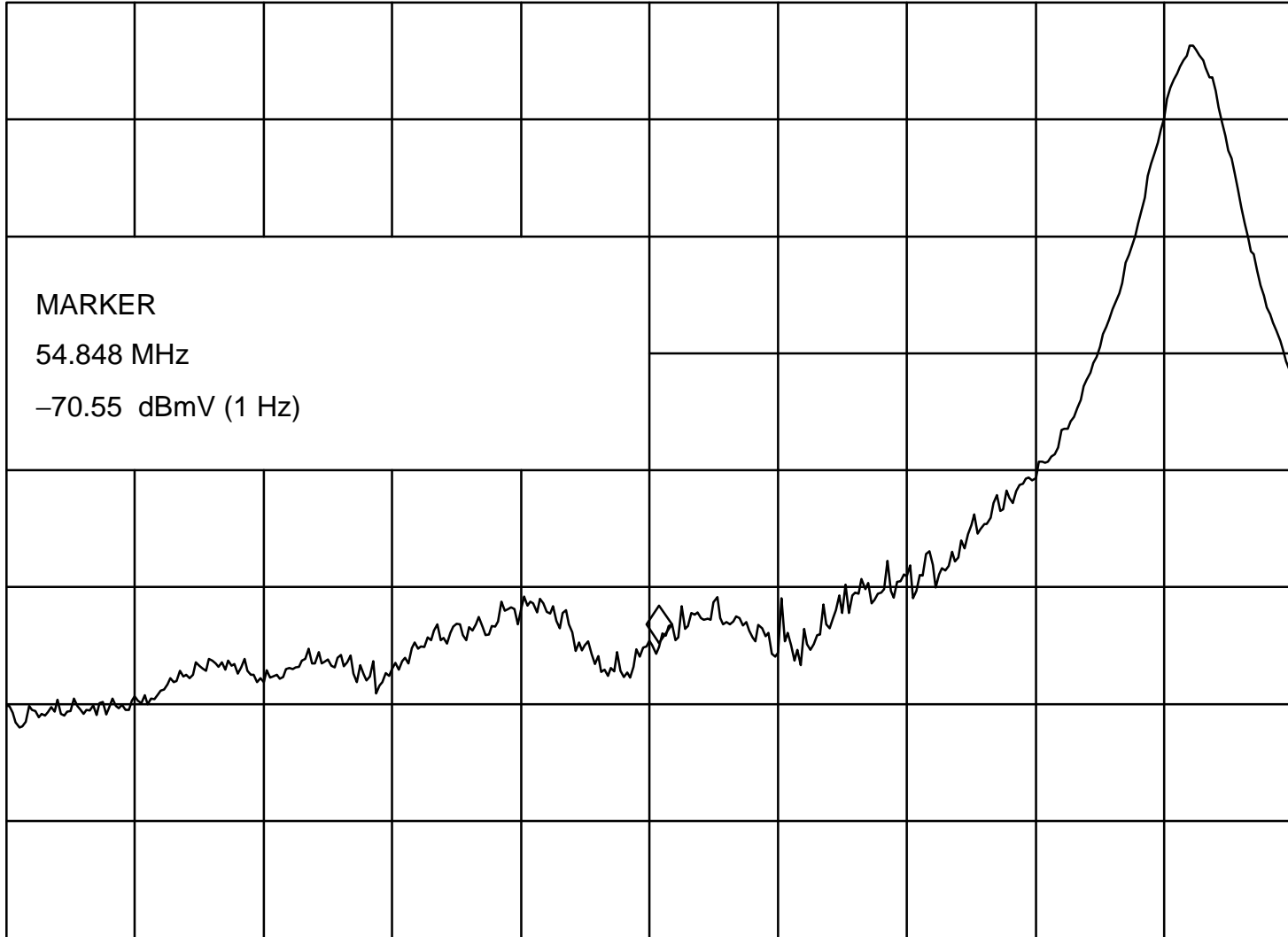
WA SB  
SC FS  
CORR

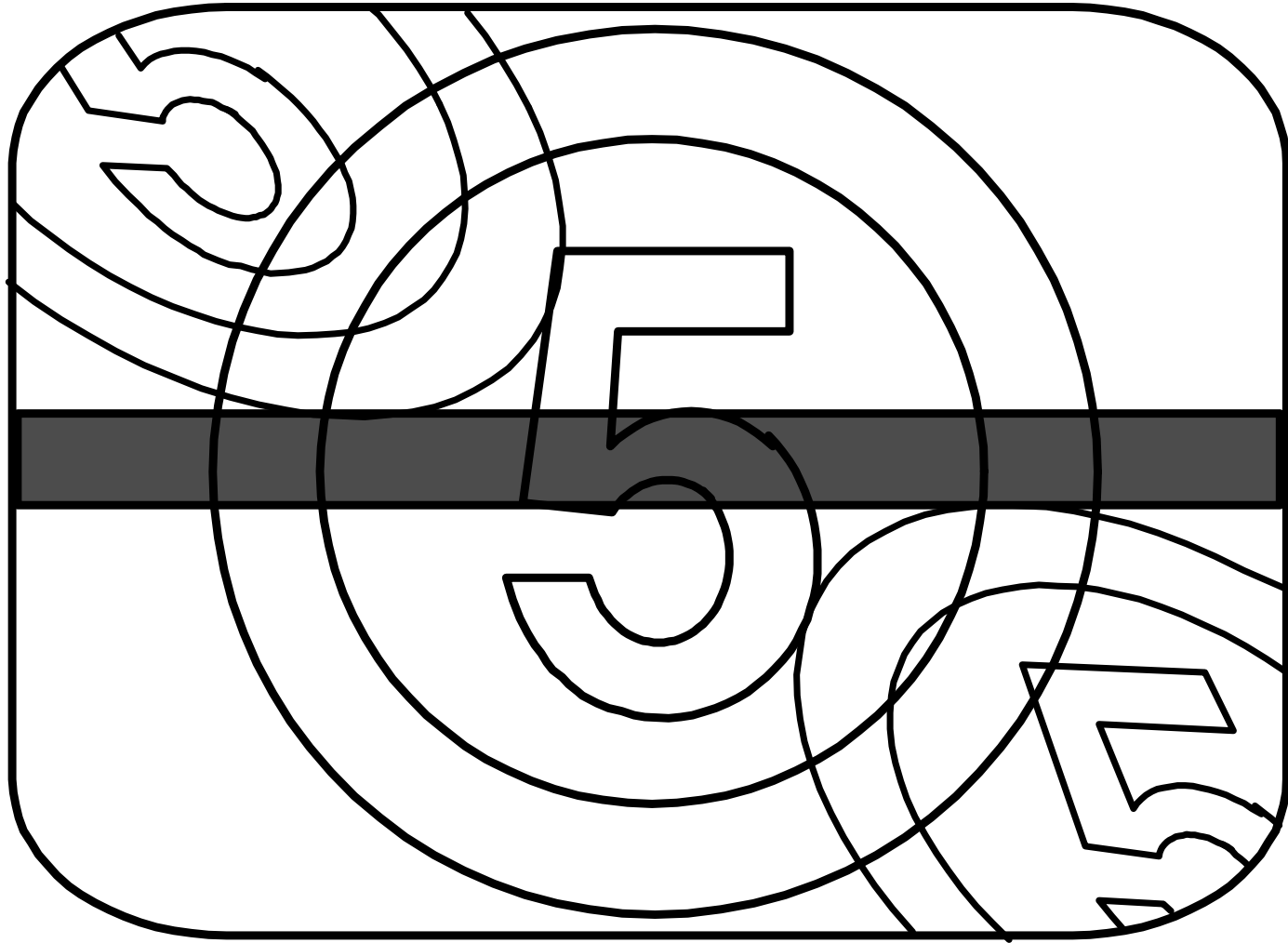
More  
1 of 2

CENTER 54.840 MHz  
RES BW 30 kHz

#VBW 100 Hz

SPAN 1.000 MHz  
SWP 1.00 sec





**CO-CHANNEL INTERFERENCE**



hp

REF -21.0 dBm

#ATTEN 0 dB

MKR  $\Delta$  10.00 kHz  
-52.63 dB

PEAK  
LOG  
10  
dB/

MARKER  
NORMAL

MARKER  
 $\Delta$

MARKER  $\Delta$   
10.00 kHz  
-52.63 dB

MARKER  
AMPTD

SELECT  
1 2 3 4

WA SB  
SC FC  
CORR

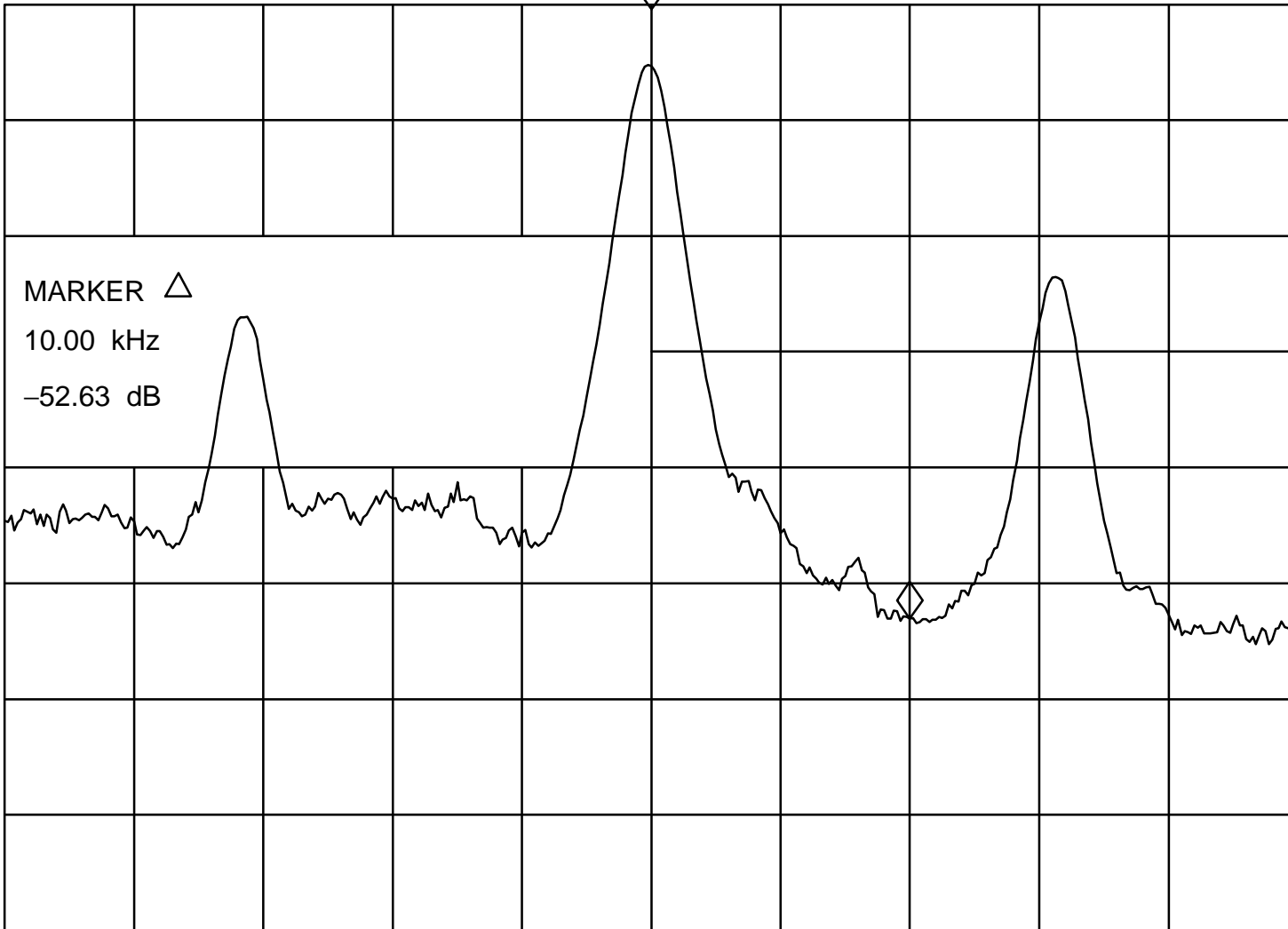
MARKER 1  
ON OFF

CENTER 55.26000 MHz  
#RES BW 1.0 kHz

#VBW 10 Hz

SPAN 50.00 kHz  
SWP 15.0 sec

More  
1 of 2





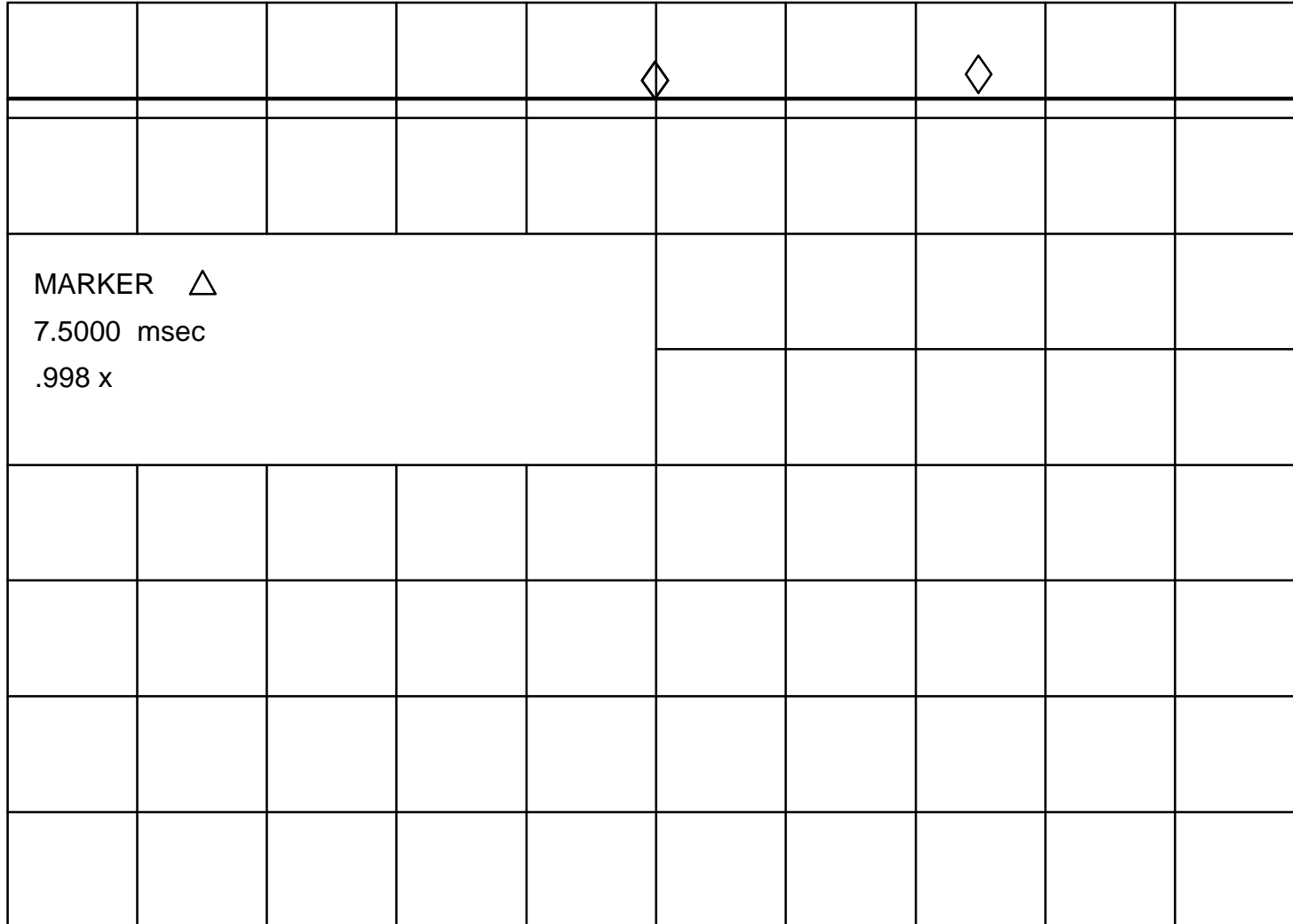
REF 12.67 mV

#ATTEN 10 dB

MKR  $\Delta$  7.5000 msec  
.998 x

PEAK

LIN



MARKER  $\Delta$   
7.5000 msec  
.998 x

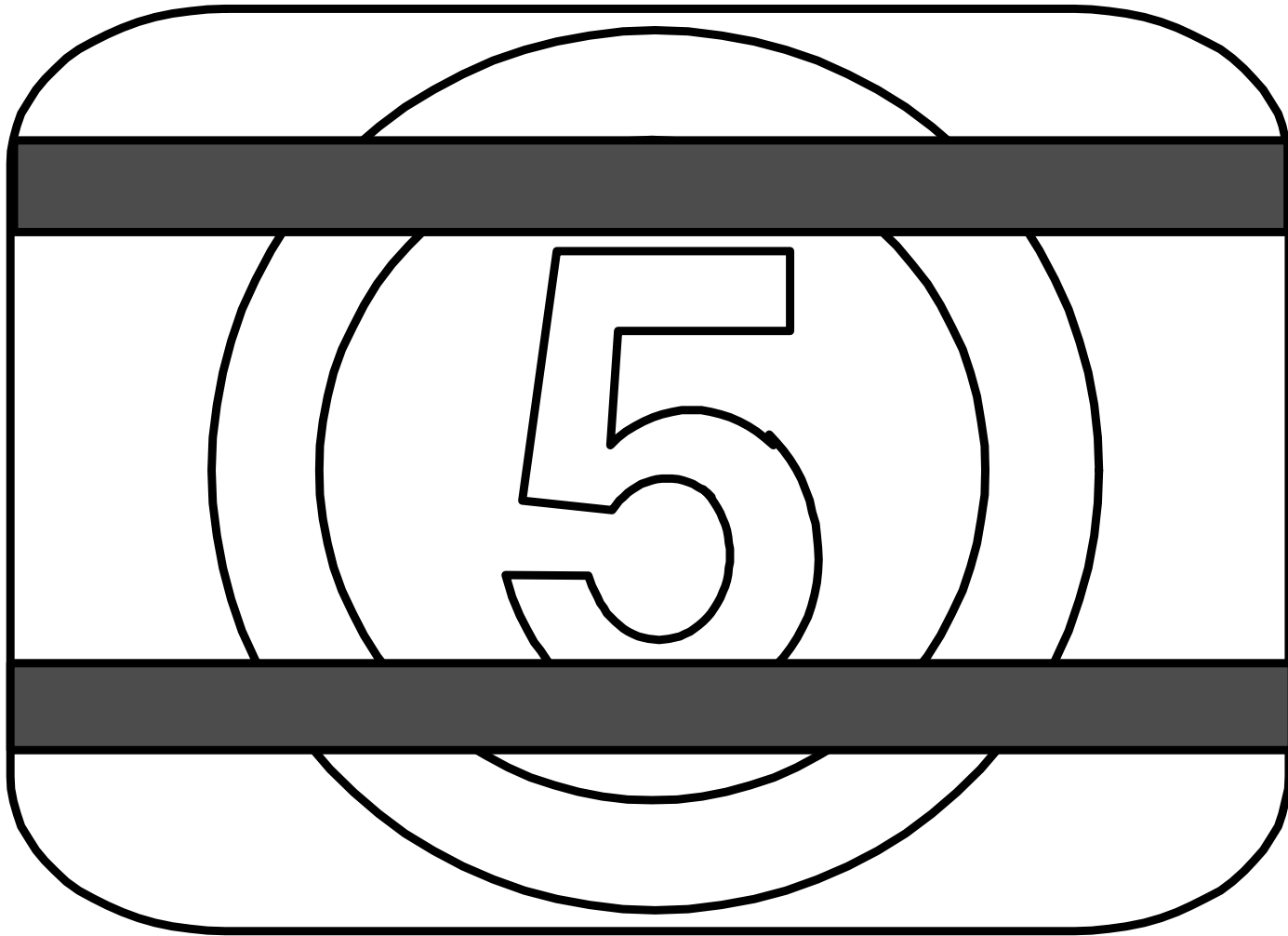
AVG  
100

WA SB  
SC FS  
CORR

CENTER 55.285 MHz  
#RES BW 1.0 MHz

#VBW 1 MHz

SPAN 0 Hz  
#SWP 30.0 msec



**HUM INTERFERENCE**

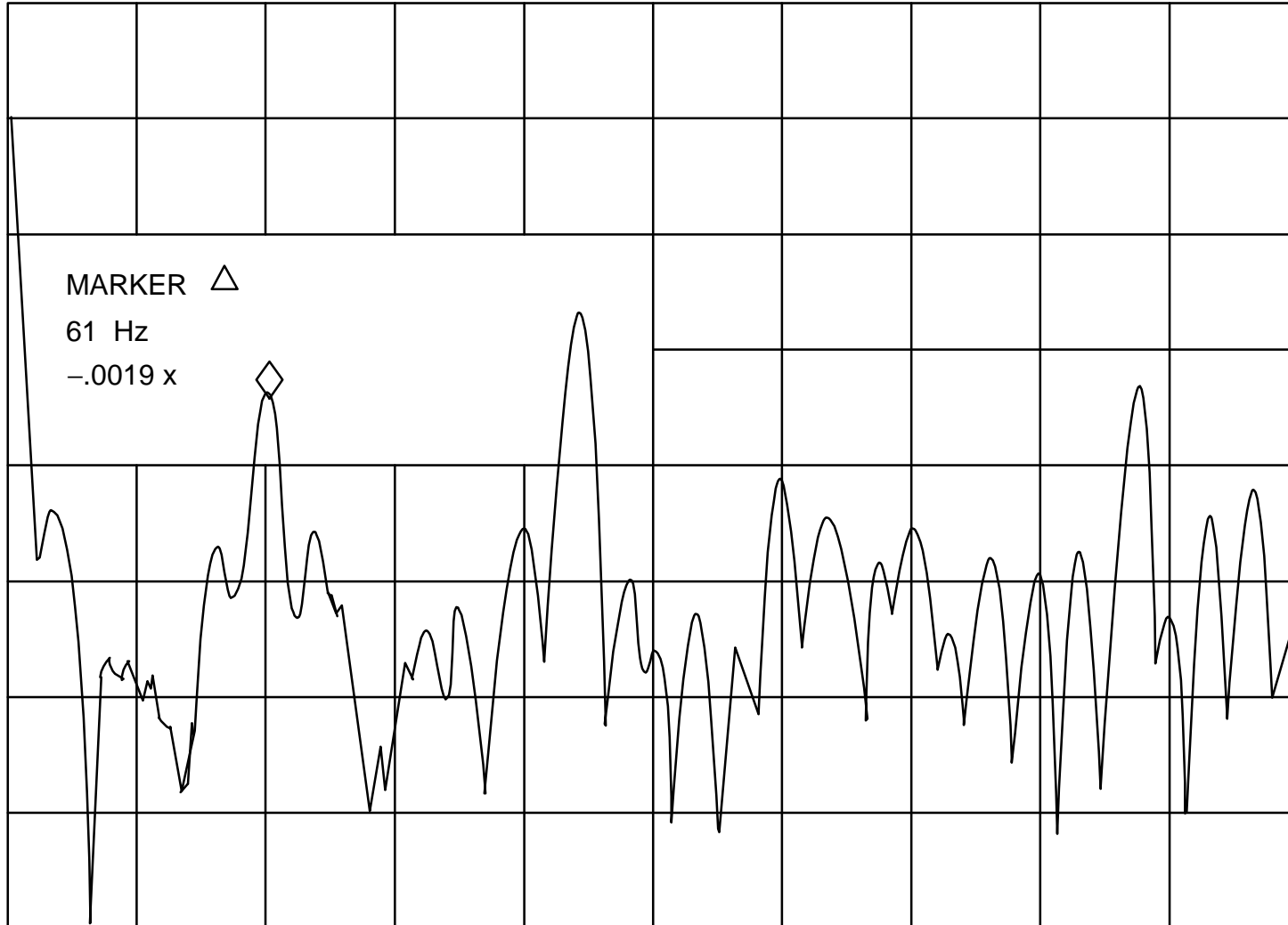


REF 8.810 mV

ATTEN 10 dB

MKR  $\Delta$  61 Hz  
-.0019 x

SMPL  
LIN



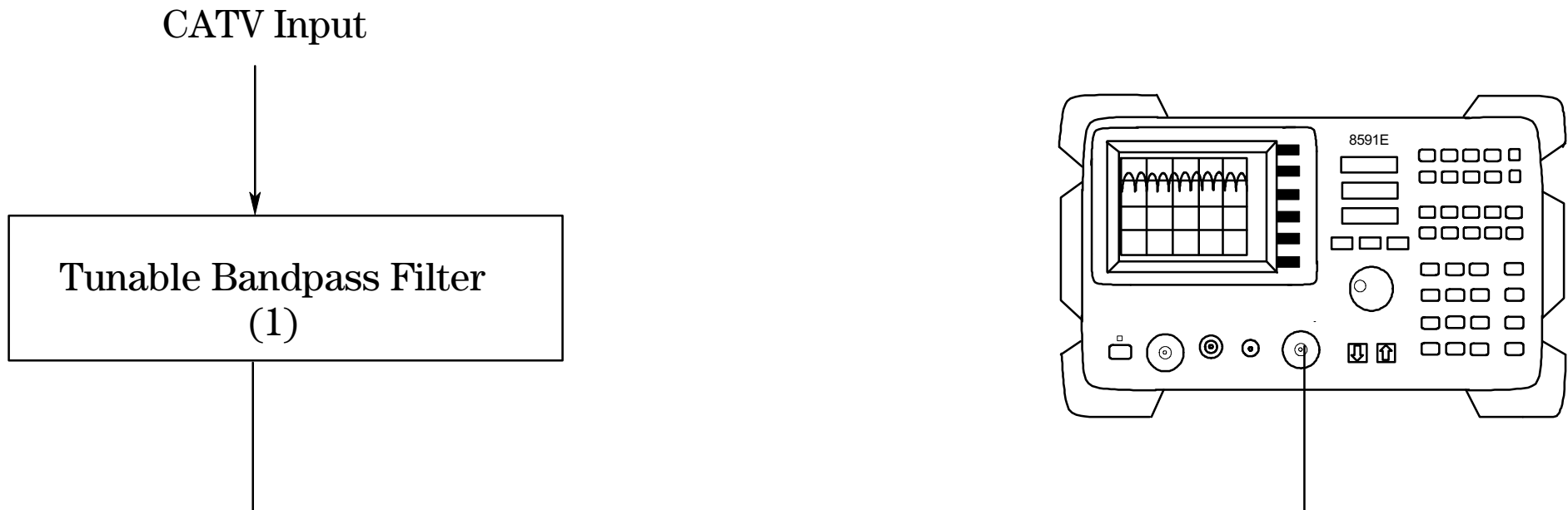
SA VB  
SC FS  
CORR

FFT START 0 Hz  
RES BW 30 kHz

#VBW 30 kHz

FFT STOP 299 Hz  
#SWP 668 msec

# Setup for Distortion Measurements (CSO/CTB)



- (1) Required when analyzer is in compression  
Total power = Carrier signal level (dBmV)  
+ 10 log (number of channels)

HP 02:51:55 JAN 12, 1993  
CHANNEL 4 (STD)

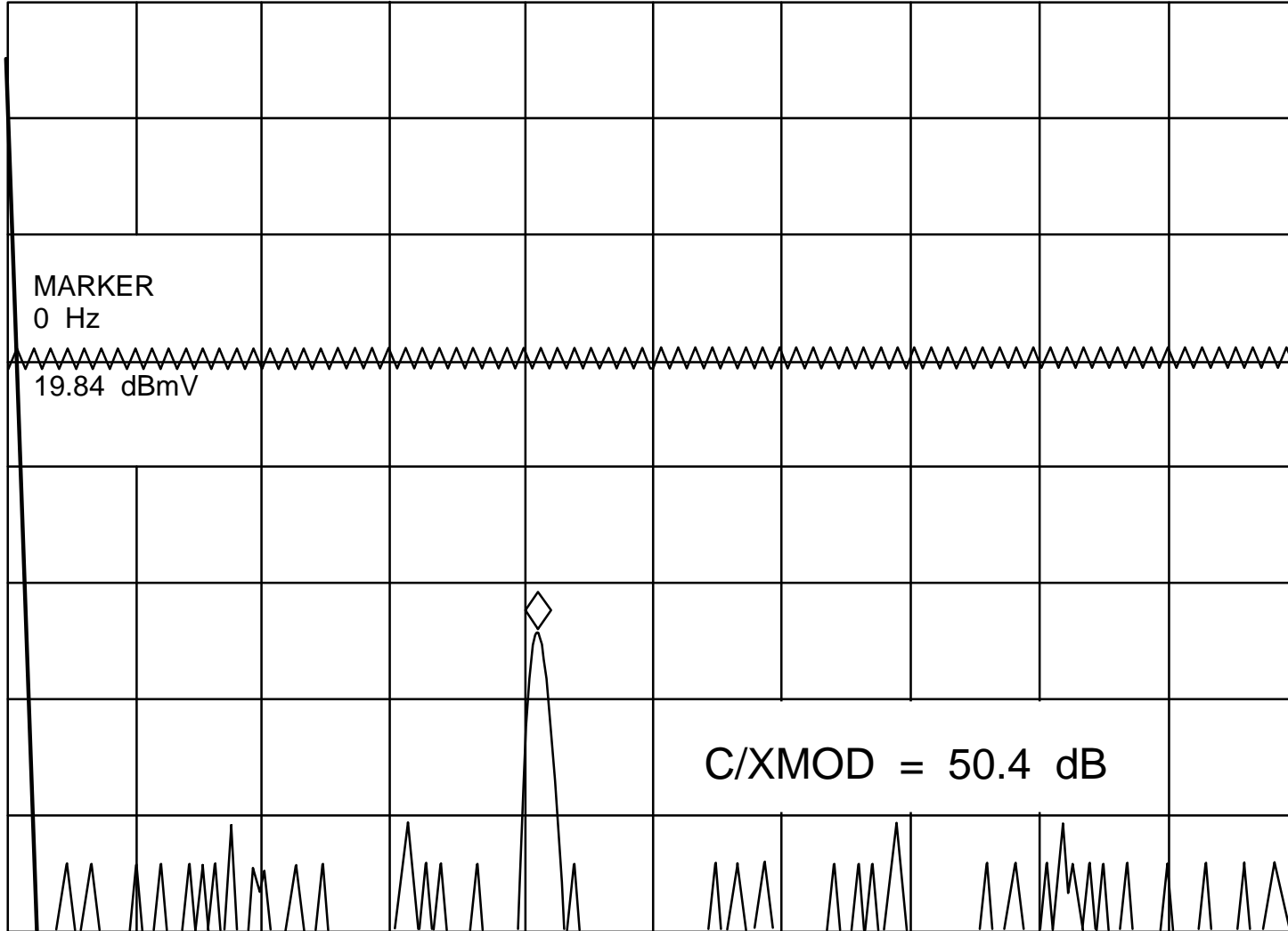
CATV

REF 24.2 dBmV

ATTEN 10 dB

MKR  $\Delta$  4.175 kHz  
-50.40 dB

SMPL  
LIN



WA SB  
VC FC  
CORR

C/XMOD = 50.4 dB

0  
nV

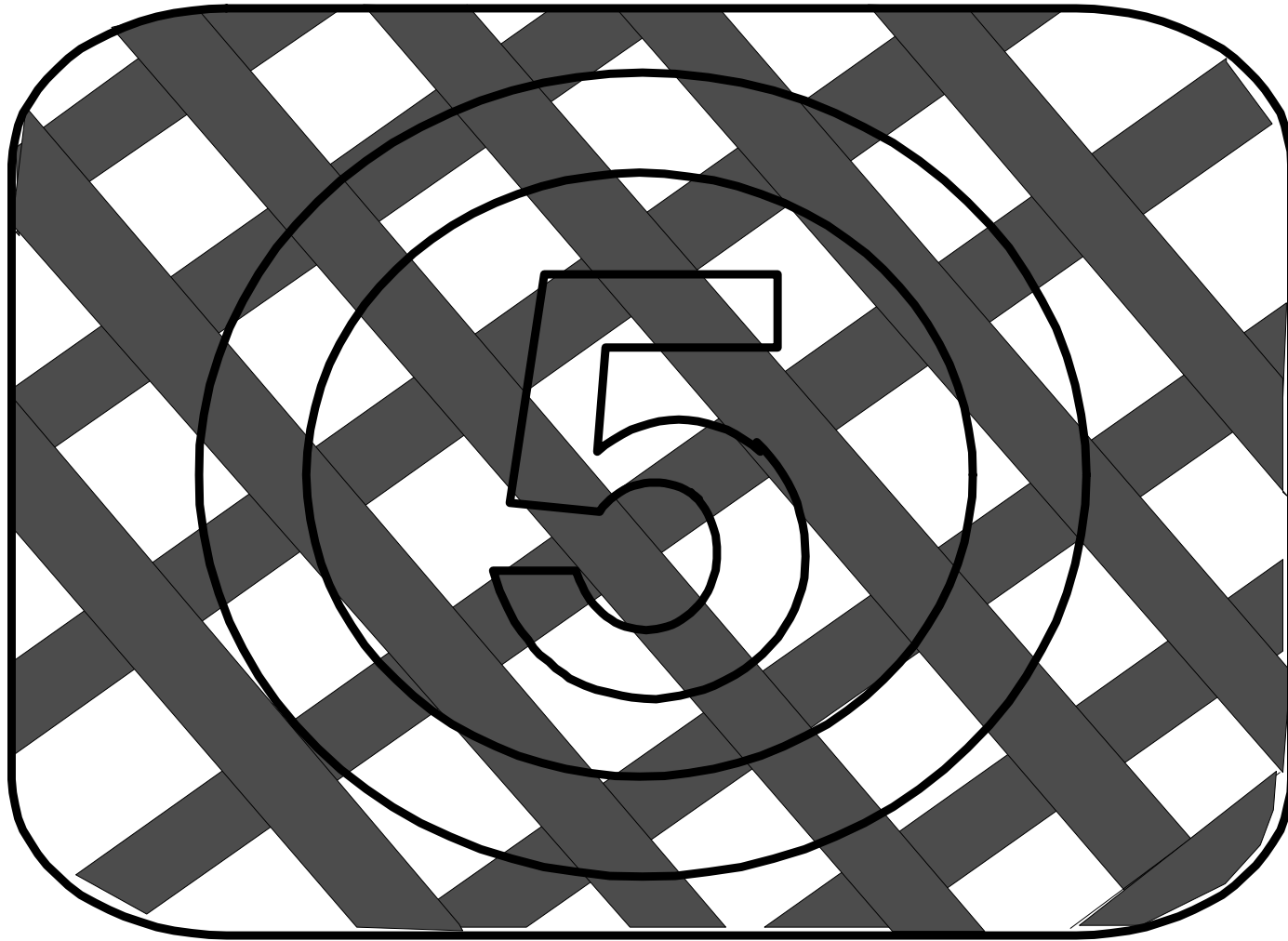
CENTER 67.255 MHz  
#RES BW 100 kHz

#VBW 100 kHz

SPAN 0 Hz  
#SWP 20.0 msec

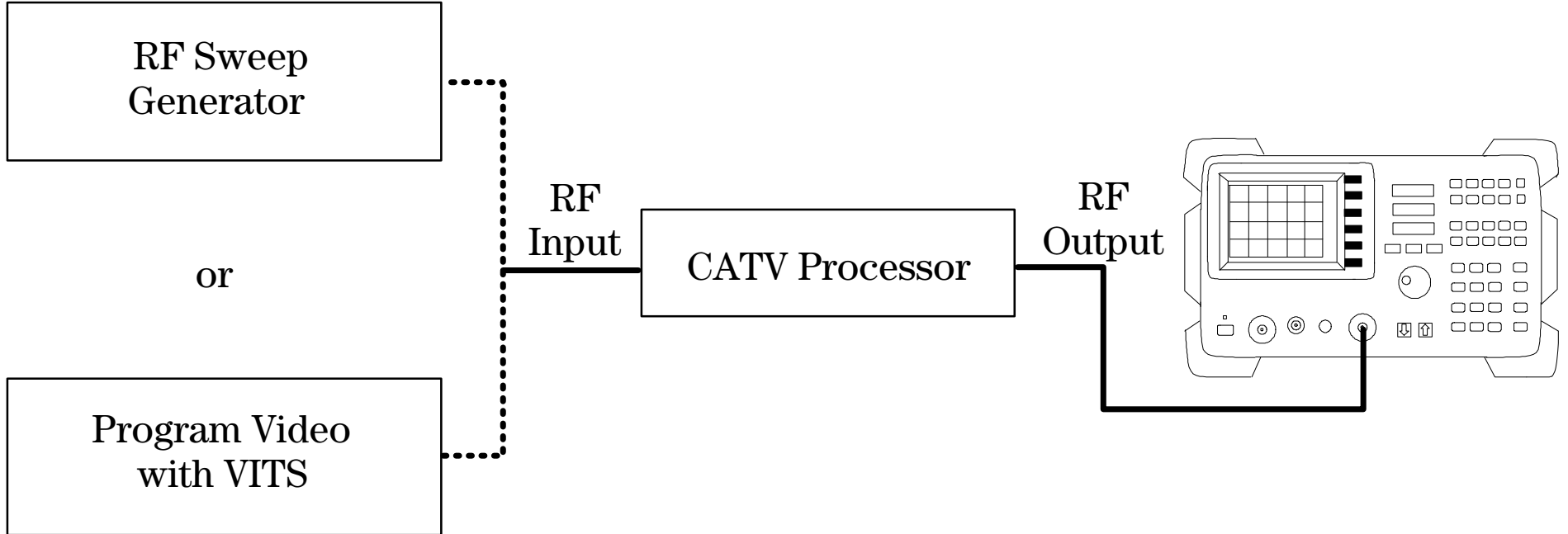
MAIN  
MENU

RT



**CROSSMODULATION**

# Testing In-Channel Frequency Response of Processors





03:47:52 JAN 12, 1993  
CHANNEL 4 (STD)

REF 29.0 dBmV

ATTEN 10 dB

MKR  $\Delta$  2.745 MHz  
-53 dB

CATV

MARKER  
→ CF

PEAK  
LOG  
10  
dB/

MARKER  
 $\Delta$

MARKER  $\Delta$   
2.745 MHz  
-53 dB

NEXT  
PEAK

NEXT PK  
RIGHT

MA SB  
SC FC  
CORR

← FCC MEASUREMENT RANGE →

NEXT PK  
LEFT

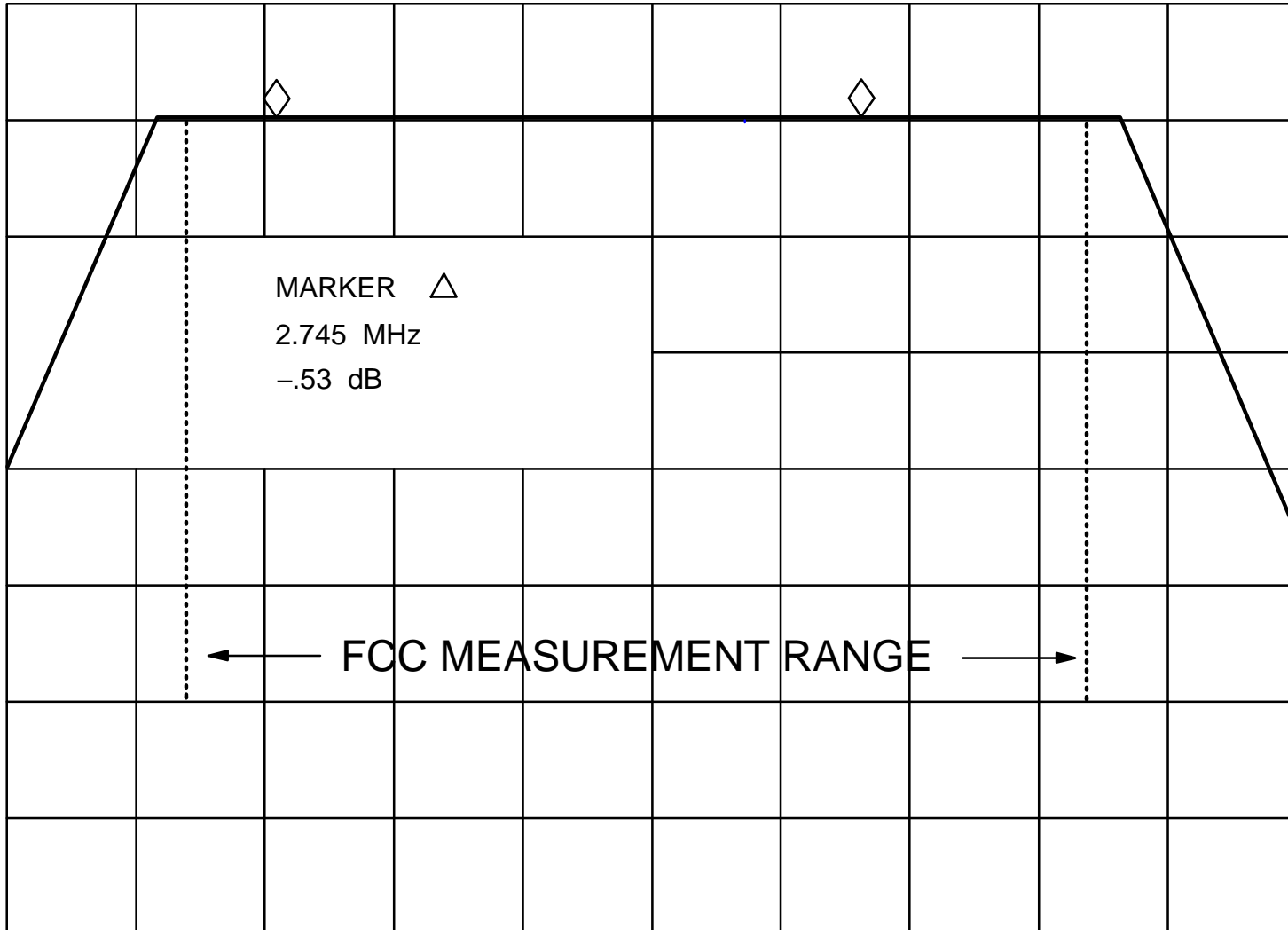
More  
1 of 2

CENTER 69.000 MHz  
#RES BW 300 kHz

#VBW 300 kHz

SPAN 6.000 MHz  
#SWP 750 msec

RT





09:46:46 FEB 03, 1993

CHANNEL 4 (STD)

REF 33.8 dBmV

ATTEN 10 dB

-40.76 dB

CATV

PEAK

LOG

10

dB/

RES BW  
100 kHz

MARKER



MAX HOLD  
ON OFF

FCC MEASUREMENT

VA SB  
SC FC  
CORR

MAIN  
MENU

CENTER 69.000 MHz

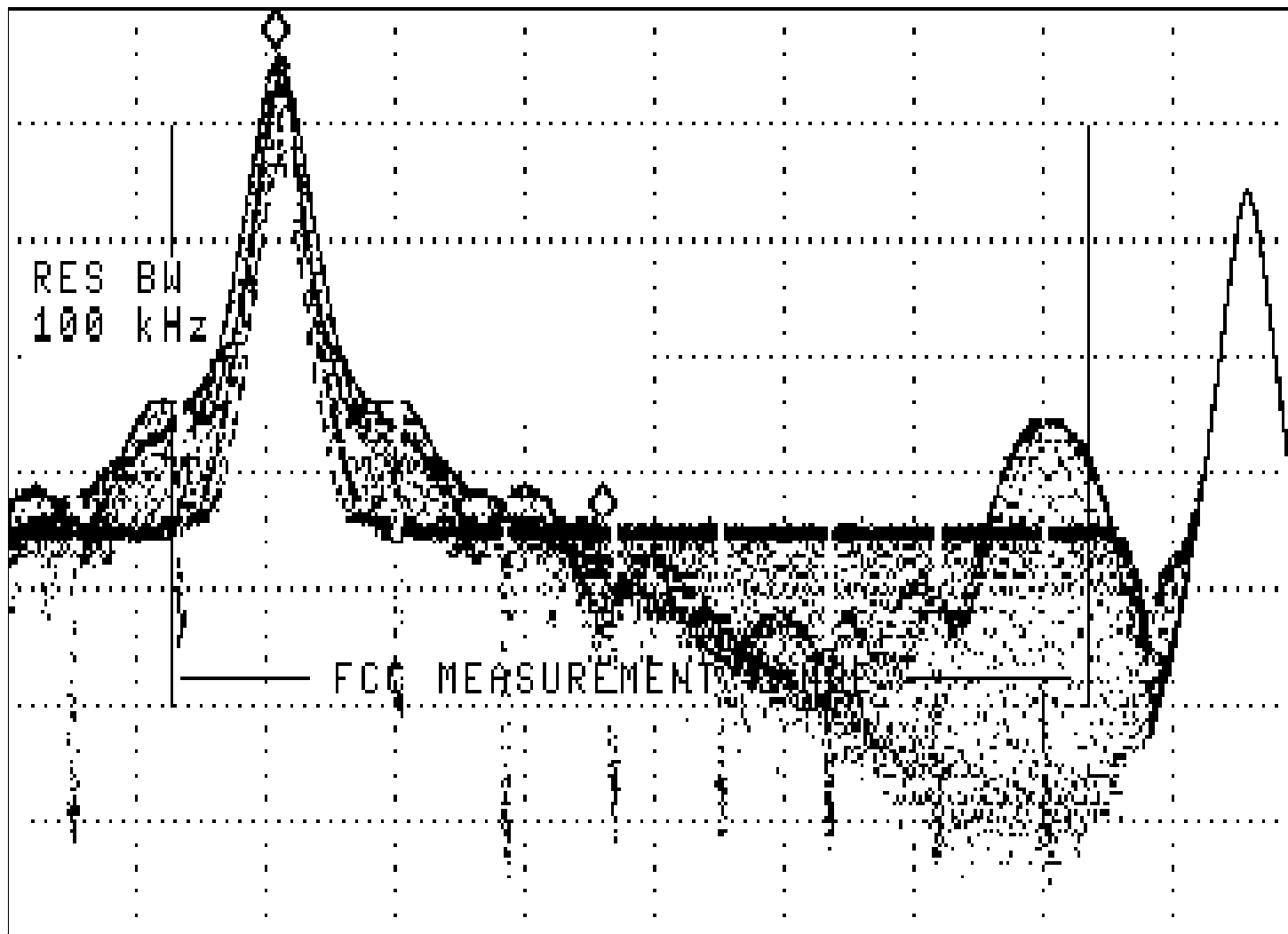
#RES BW 100 kHz

#VBW 300 kHz

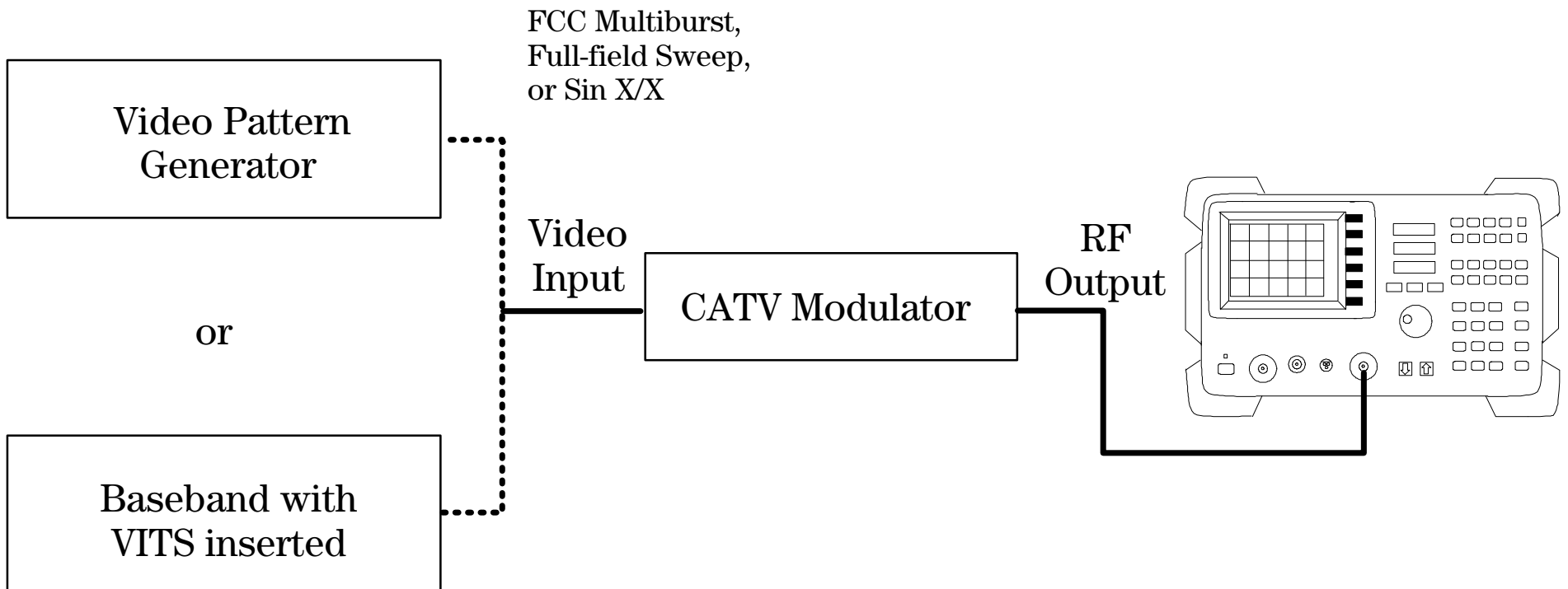
SPAN 6.000 MHz

#SWP 200 msec

R



# Testing In-Channel Frequency Response for Modulators

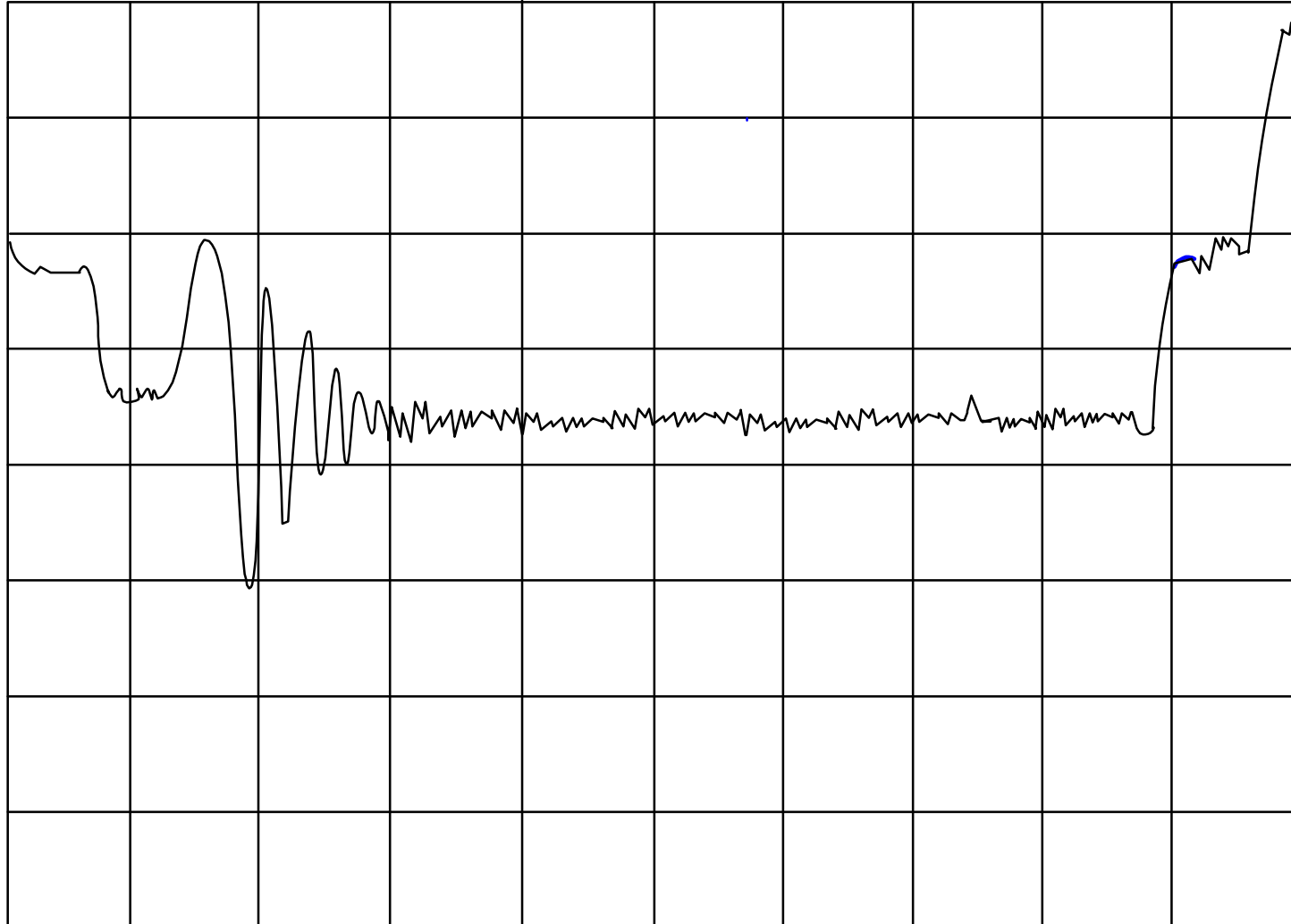


hp

REF 732.0  $\mu$ V

#ATTEN 0 dB

PEAK  
LIN



HOLD

DSP LINE  
ON OFF

Change  
Title

Limit  
Lines

WA SB  
SC TS  
CORR

ANALOG  
ON OFF

More  
1 of 2

CENTER 55.380 MHz  
#RES BW 1.0 MHz

#VBW 3 MHz

SPAN 0 Hz  
#SWP 60  $\mu$ sec

hp

REF -50.0 dBm

ATTEN 0 dB

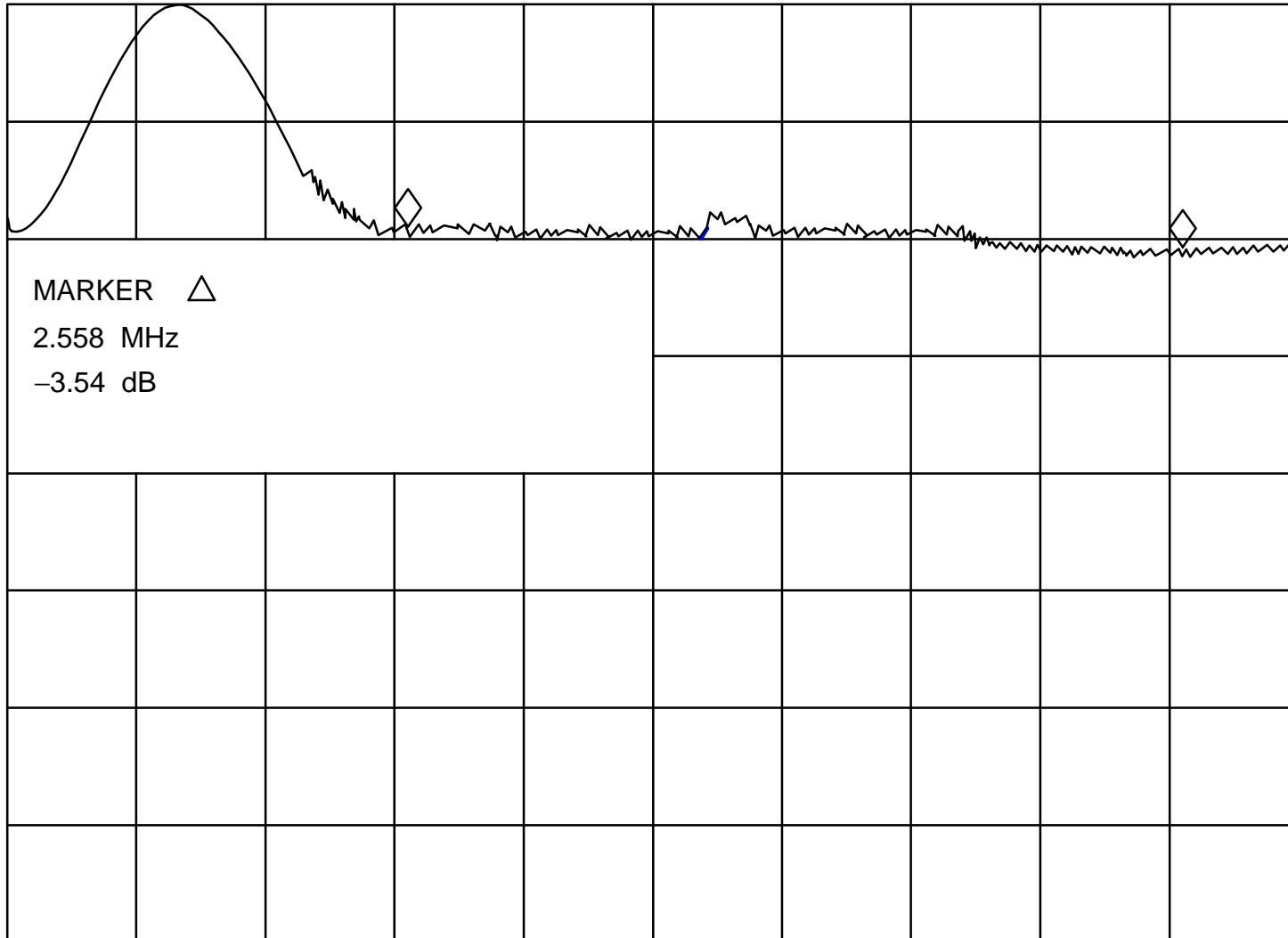
MKR  $\Delta$  2.558 MHz  
-3.54 dB

PEAK

LOG

10

dB/



MARKER  
NORMAL

MARKER  
 $\Delta$

MARKER  
AMPTD

SELECT  
1 2 3 4

WA SB  
SC FS  
CORR

MARKER 1  
ON OFF

More  
1 of 2

CENTER 56.073 MHz  
RES BW 300 kHz

#VBW 300 kHz

SPAN 4.245 MHz  
#SWP 14.0 sec

hp

REF 910.9  $\mu$ V

ATTEN 0 dB

MKR  $\Delta$  -19.600  $\mu$ sec

.123 x

PEAK

LIN

MARKER

→ CF

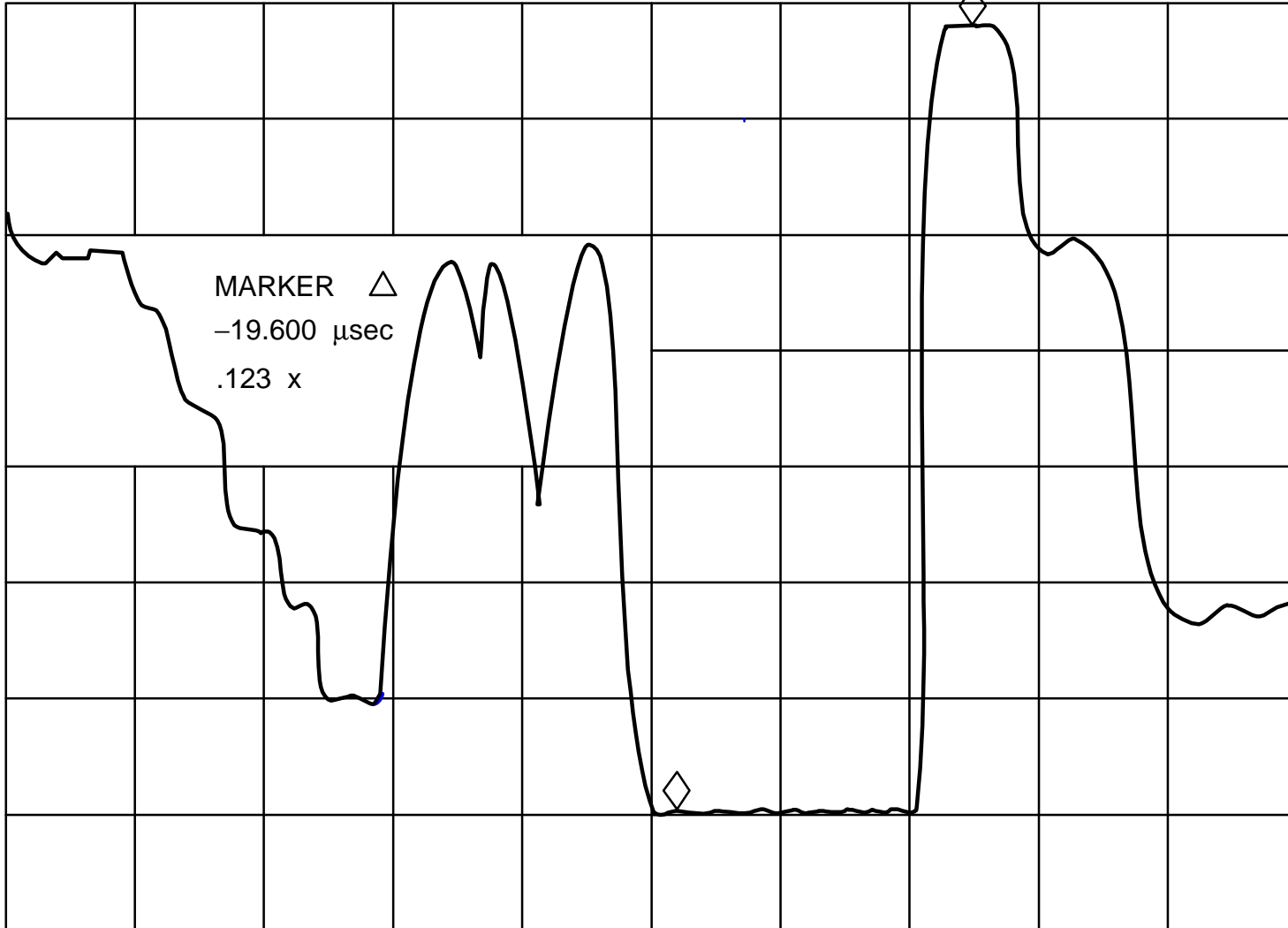
MARKER  
 $\Delta$

NEXT  
PEAK

NEXT PK  
RIGHT

NEXT PK  
LEFT

More  
1 of 2



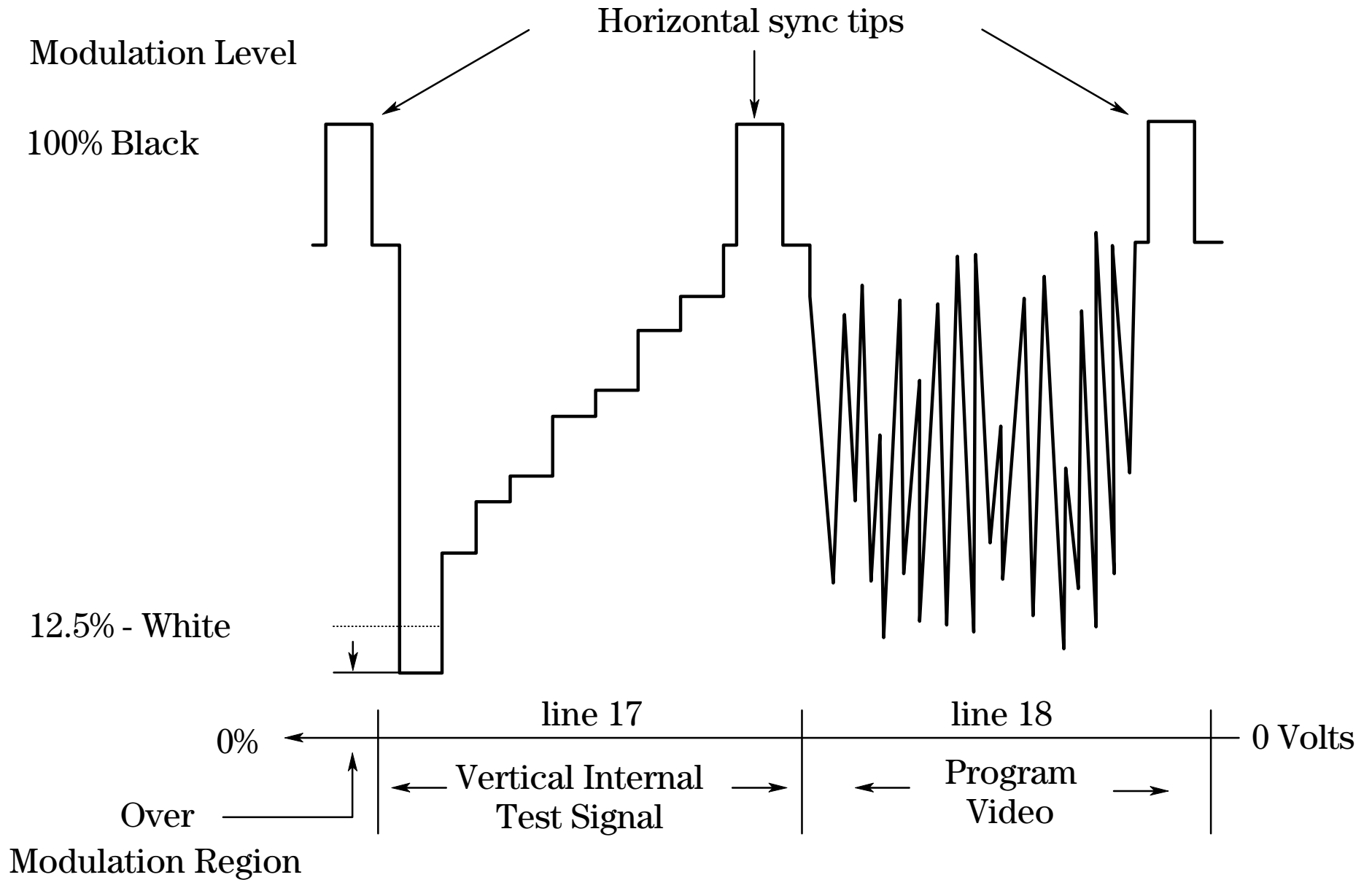
WA SB  
SC TS  
CORR

CENTER 55.300 MHz  
#RES BW 1.0 MHz

#VBW 300 kHz

SPAN 0 Hz  
#SWP 80  $\mu$ sec

# Video Signal on Horizontal Lines





REF -30.0 dBm

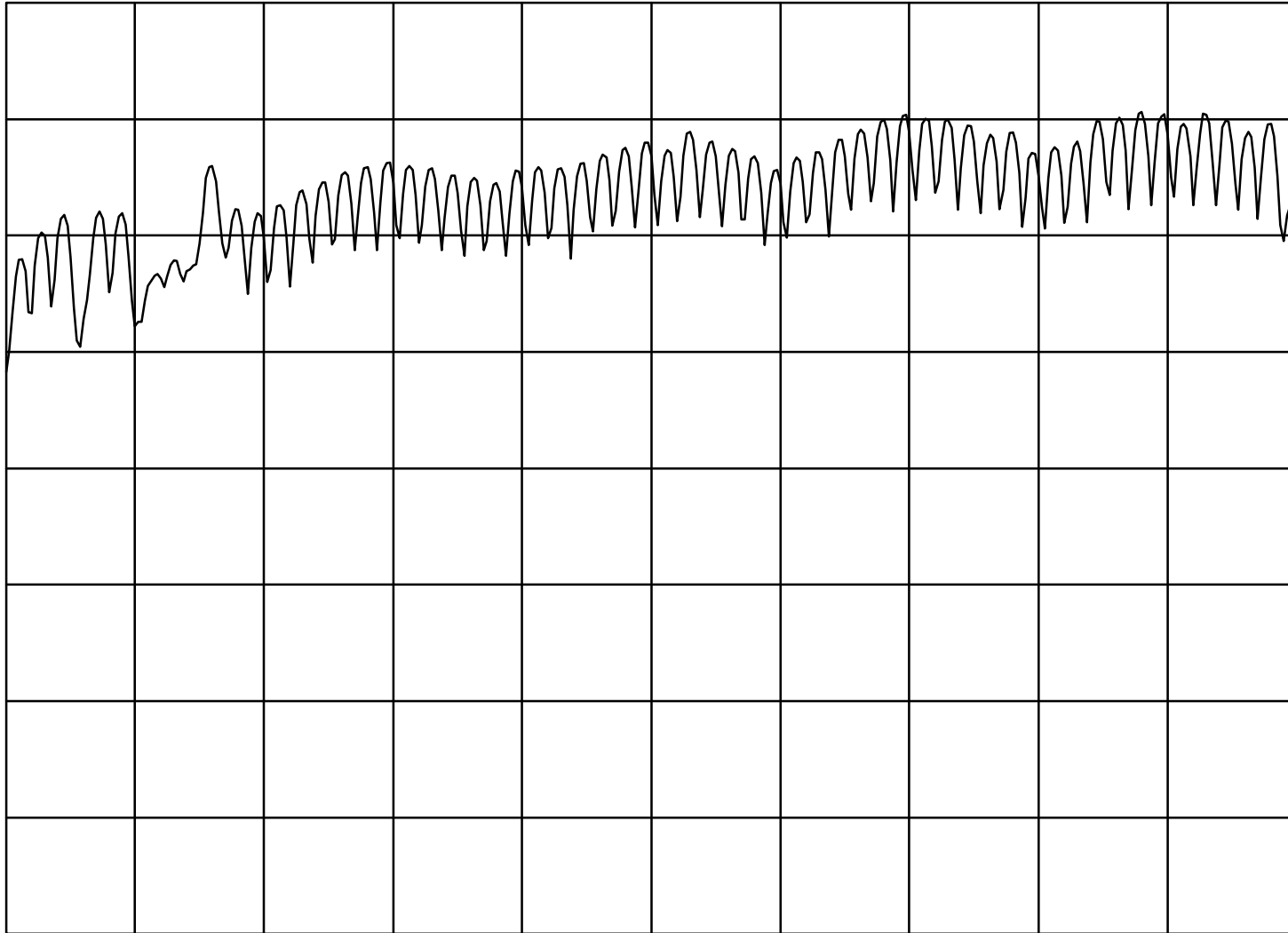
#ATTEN 0 dB

PEAK

LOG

10

dB/



SA VB  
SC FC  
CORR

START 50.0 MHz  
#RES BW 3.0 MHz

#VBW 1 MHz

STOP 410.0 MHz  
#SWP 20.0 msec



15:24:16 JUN 15, 1993

MKR  $\triangle$  72.9 MHz  
-2.56 dB

REF -30.0 dBm

ATTEN 10 dB

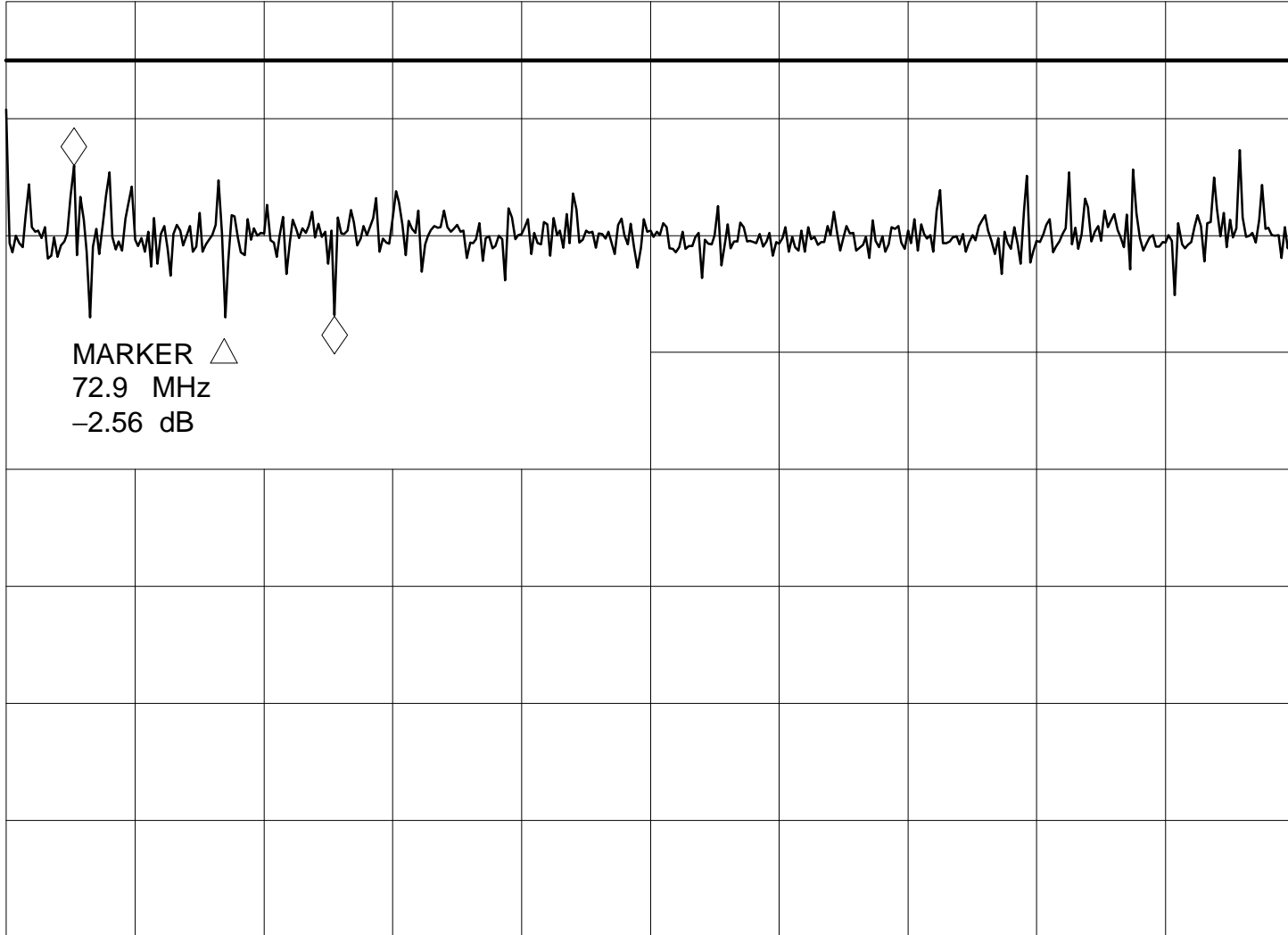
MARKER  
NORMAL

PEAK

LOG

2  
dB/

DL  
-31.0  
dB



MARKER  $\triangle$   
72.9 MHz  
-2.56 dB

MARKER  
 $\triangle$

MARKER  
AMPTD

SELECT  
1 2 3 4

MARKER 1  
ON OFF

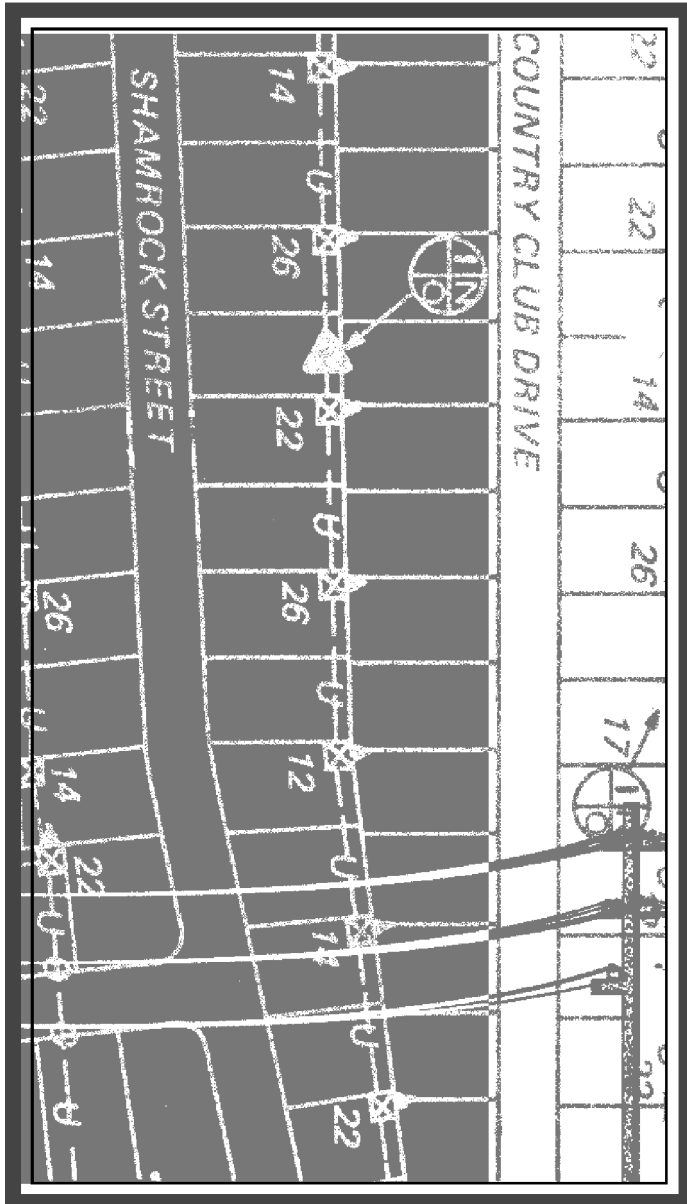
More  
1 of 2

MA SB  
SC FS  
CORR

START 50.0 MHz  
#RES BW 3.0 MHz

#VBW 1 MHz

STOP 410.0 MHz  
#SWP 20.0 msec



**Hewlett-Packard Company**  
Microwave Instruments Division  
Marketing Training Group  
1400 Fountain Grove Parkway  
Santa Rosa, CA 95403-1799

© 1994 Hewlett-Packard Company  
Printed in USA 2/94 (revised)  
5091-8037E